

# **HIGH VOLTAGE SOLAR ARRAY ARC TESTING FOR A DIRECT DRIVE HALL EFFECT THRUSTER SYSTEM**

**Todd Schneider**

NASA Marshall Space Flight Center  
Environmental Effects Group, Mailstop ED31  
Huntsville, AL 35812  
Phone: (256) 544-2595  
E-mail: [todd.a.schneider@nasa.gov](mailto:todd.a.schneider@nasa.gov)

**M.R. Carruth, Jr.**

**J.A. Vaughn**

NASA Marshall Space Flight Center, Huntsville, AL

**G.A. Jongeward**

**I.G. Mikellides**

Science Applications International Corporation, San Diego, CA

**D. Ferguson**

**T.W. Kerlake**

**T. Peterson**

**D. Snyder**

NASA Glenn Research Center at Lewis Field, Cleveland, OH

**A. Hoskins**

Aerojet Corporation, Redmond, WA

## **Abstract**

The deleterious effects of spacecraft charging are well known, particularly when the charging leads to arc events. The damage that results from arcing can severely reduce system lifetime and even cause critical system failures. On a primary spacecraft system such as a solar array, there is very little tolerance for arcing. Motivated by these concerns, an experimental investigation was undertaken to determine arc thresholds for a high voltage (200-500 V) solar array in a plasma environment. The investigation was in support of a NASA program to develop a Direct Drive Hall-Effect Thruster (D2HET) system. By directly coupling the solar array to a Hall-effect thruster, the D2HET program seeks to reduce mass, cost and complexity commonly associated with the power processing in conventional power systems. In the investigation, multiple solar array technologies and configurations were tested. The cell samples were biased to a negative voltage, with an applied potential difference between them, to imitate possible scenarios in solar array strings that could lead to damaging arcs. The samples were tested in an environment that emulated a low-energy, HET-induced plasma. Short duration “trigger” arcs as well as long duration “sustained” arcs were generated. Typical current and voltage waveforms associated with the arc events are presented. Arc thresholds are also defined in terms of voltage, current and power. The data will be used to propose a new, high-voltage (>300 V) solar array design for which the likelihood of damage from arcing is minimal.

## **Introduction**

In the quest to create lighter more efficient spacecraft, the natural trend is toward higher voltage power systems. High voltage power systems offer more power for less mass – due to reduced resistive ( $I^2R$ ) losses in conductors that carry lower currents but deliver the same power (Power = Current x Voltage). Unfortunately, the efficiency gains of operating at high voltage can be offset by spacecraft charging problems. Nowhere is this trade-off between system efficiency and spacecraft charging more evident than in the case of high voltage solar arrays operating in a plasma environment. High voltage solar arrays can exhibit parasitic current collection as well as arcing when immersed in a plasma.<sup>1,2,3</sup>

The Direct Drive Hall-Effect Thruster (D2HET) program is an excellent example of a power system design that benefits from mass savings as a result of high voltage solar array operation.<sup>4,5</sup> In the D2HET concept, the anode of a Hall-Effect Thruster (HET) is driven directly by a high voltage (300 V) solar array. Operation in this manner significantly reduces the mass of a Power Processing Unit, by eliminating the transformer stage that is usually responsible for increasing the standard 28 – 40 Volt array power to 300 Volts. However, the high voltage solar arrays in a D2HET system must be capable of operating in the charge exchange plasma that is generated in the HET plume. In addition, the arrays must also be capable of operation in the natural plasma environment around the Earth – as might be the case for orbit raising applications. Therefore, it was necessary for the D2HET program to find a robust high voltage solar array that would have minimal (electron) current collection and greatly reduced potential for arcing.

In order to find the next generation of high voltage solar arrays, the D2HET program investigated current collection phenomena and arcing thresholds using several existing solar array technologies. The results of the electron current collection studies are described by Mikellides.<sup>6</sup> The purpose of this paper is to describe the results associated with arc tests that have been conducted. The results of the current collection tests and the arcing tests have been used to create a hybrid solar array design that is expected to function efficiently in harsh charging environments.

## **Experiment Set-up**

To accomplish the task of determining arc thresholds as well as understanding solar array arc characteristics, a plasma test chamber was set-up at NASA Marshall Space Flight Center. The test chamber (Figure 1) is a cylindrical vacuum chamber with a 1.2 m inside diameter and a useable length of 1.7 m. Two liquid nitrogen trapped diffusion pumps maintain the base vacuum pressure at  $5 \times 10^{-7}$  Torr. The plasma is created by a hollow cathode plasma source. In order to reduce interaction between the plasma source and the biased solar array, the “keeper” electrode of the hollow cathode is grounded. Using argon gas at an operating pressure of  $8 \times 10^{-5}$  Torr, the typical plasma conditions are: Density =  $5-10 \times 10^6 \text{ cm}^{-3}$ , Electron temperature = 0.5-1 eV, and Plasma potential ~ -20 volts. The plasma parameters are determined by using a 3.8 cm diameter spherical Langmuir probe. To monitor the solar array samples in the chamber, a video camera is placed at one end of the vacuum vessel in line with a viewport. The camera is connected to a video system that provides a means of visually determining the position of an arc on the array.

To facilitate the reviewing process, the video system is equipped with a time-date generator as well as a title maker. The video system is shown in Figure 2.

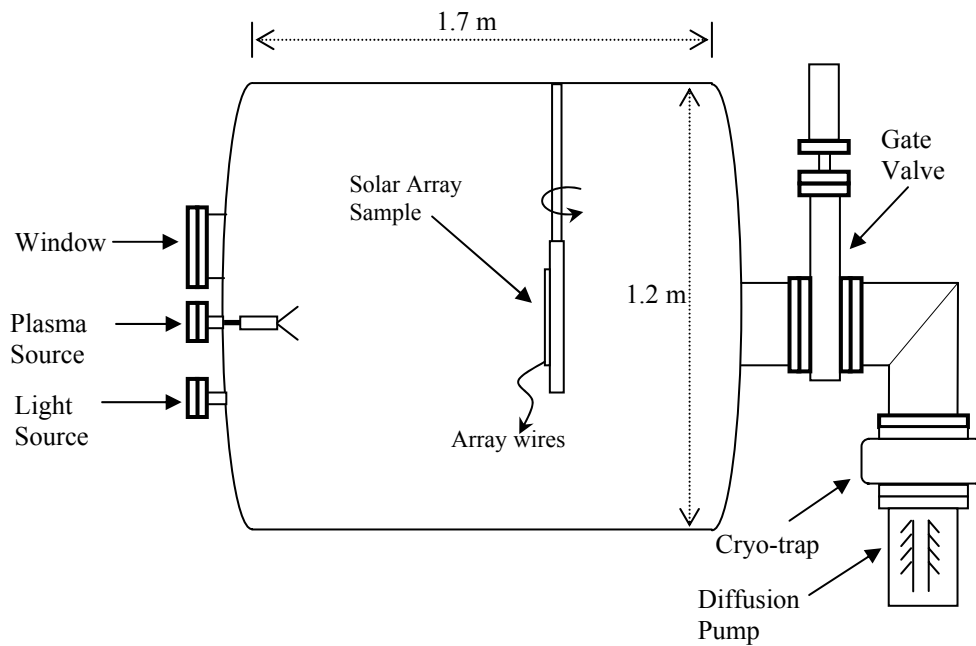

**Figure 1. Plasma Test Chamber.**

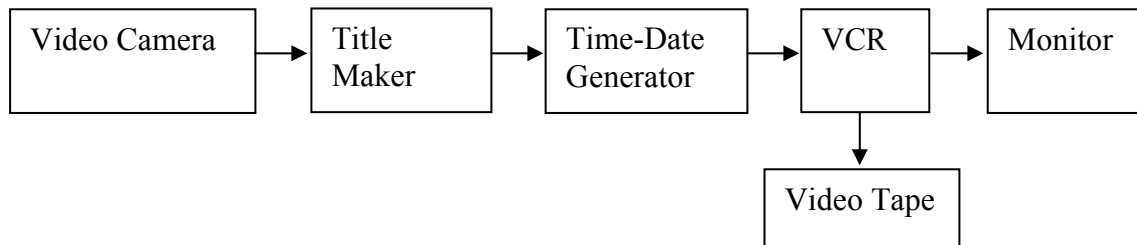
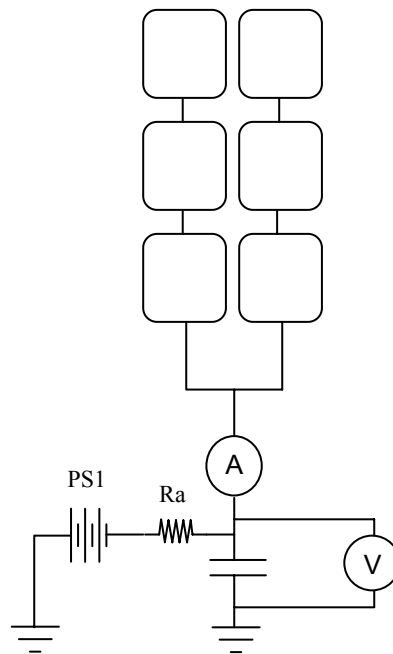

**Figure 2. Block diagram of the video system used to capture arc events on tape.**

In space, it has been observed that solar arrays biased negative with respect to the surrounding plasma are subject to experiencing arcing events.<sup>7</sup> The arcs vary in duration and peak current values. Previous ground based test have confirmed the existence of two general categories of arcs: 1) Trigger Arcs and 2) Sustained Arcs.<sup>8</sup> Trigger arcs are characterized as short duration (~20 microseconds) high peak current (>20 amps) discharges. The primary energy source for a trigger arc is the intrinsic capacitance of the array. Trigger arcs are not usually responsible for damaging the solar array; however, they are considered a catalyst for sustained arc events. Sustained arcs, as the name implies, are long duration arcs (>1 millisecond), but with low current (<10 amps) demand. Sustained arcs represent the greatest

threat to the solar array survivability. Sustained arcs are likely to occur at the interface between two solar cells that have a significant differential voltage between them – as might be the case for two cells in separate strings on the array. Sustained arcs utilize the photovoltaic power generated from each string to supply their energy requirements.

In order to generate both trigger and sustained arcs in ground based testing, two separate circuits are required. Figure 3 shows the circuit used to generate a trigger arc. The trigger arc circuit requires a capacitor that is representative of the self-capacitance associated with a full array. For this experiment, the capacitance used was 1.0 microfarad. This value was chosen based on the design reference missions that were specified at the outset of the D2HET project.<sup>9</sup>



**Trigger Arc Circuit**

**Figure 3. Basic schematic of the trigger arc circuit.**

To generate a sustained arc, a power supply (PS2) is added to the trigger arc system (Figure 4). This supply, known as the differential power supply, is a current limited supply that simulates the power created by a solar array string under illumination. The events leading to a sustained arc have been described by Hastings<sup>10</sup> and Ferguson.<sup>11</sup> The process is believed to occur under conditions where a trigger arc is initiated at the interface between two adjacent cells that have a voltage difference between them. The arc plasma from the trigger arc creates a conductive “bridge” across the interface that allows for current to flow between the two adjacent cells. This current flow between cells can result in significant heating of the cell material, cover glass, and substrate. In fact, it has been observed in this experiment as well as in space, the heat from a sustained arc can cause significant damage by melting cell edges, damaging interconnects, and pyrolyzing Kapton substrates – which can result in a conductive path of material (carbon) being created between two cells.

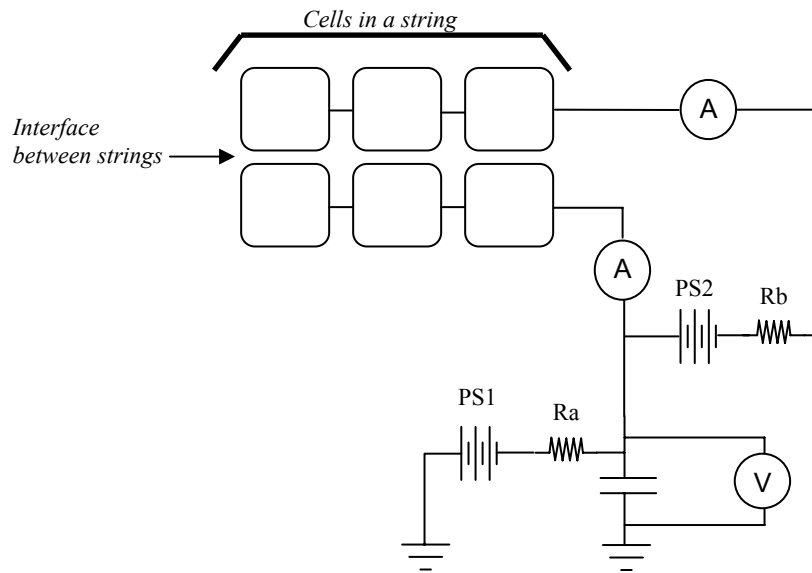

**Sustained Arc Circuit**

**Figure 4. Basic schematic of the sustained arc circuit.**

Given the potential for damage to an array as a result of a sustained arc event, it is important to determine the arc threshold for a given array and to either operate the array below this threshold or to initiate an array design that eliminates the possibility of sustained arcs. With this in mind, the D2HET program set out to determine if there was an existing array technology that was capable of operating at  $-300$  volts without experiencing an arc event. If such an array were found, the electron current collection of the candidate array would be assessed and compared to the mission design goals before it would be chosen as the appropriate technology for a D2HET mission. On the other hand, if none of the technologies tested met the arc threshold specification, then a new array design could be created based on the test results.

### **Sample Descriptions**

A wide range of solar array designs presently exists and new lightweight high-efficiency designs continue to be produced. To help reduce the number of candidate test samples for the D2HET program, an emphasis was placed on technologies that appeared to be suited for use at high voltages (300 volts). Ultimately, three different array technologies were chosen.

The first type of solar array tested was based on the design used for the International Space Station (ISS). ISS solar arrays have been designed to operate at relatively high voltage (160 volts) and have demonstrated continuous operation in space for years. A key feature of the ISS array is the use of interconnects which are completely covered by an insulating film (Kapton). However, the cell edges are exposed, which allows current collection. A picture of the sample coupon is shown in Figure 5.

The second technology chosen for testing was named “Planar TECSTAR”.<sup>12</sup> In contrast to ISS, the Planar TECSTAR design employs exposed interconnects on some parts of the sample coupon. A picture of the coupon is shown in Figure 6. The connections at the top and bottom of the sample are exposed, however, the connections in the middle of each two cell module are covered by coverglass. The cells are mounted on top of a Kapton film. The film in turn rests on top of a rigid structure formed from graphite sheets with an aluminum honeycomb structure in the middle.

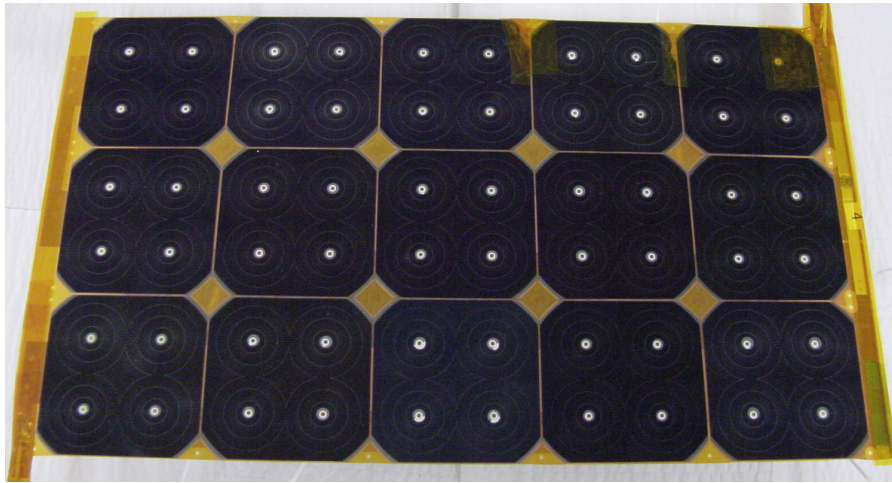

**Figure 5. Photograph of the ISS Solar Array sample.**

The third type of solar array sample tested was referred to as the “TECSTAR Concentrator”. This sample design is unique due to the fact that a triangular shaped metallized dielectric film is placed between the two photovoltaic modules. This is part of a design that is intended to concentrate more light on each individual cell. As this is an emerging technology, and since the photovoltaic modules are separated by a greater distance, it is reasonable to expect a reduced chance of arcing between cells. The TECSTAR Concentrator sample is shown in Figure 7.

Although not a distinct technology, a fourth sample coupon was created to explore some of the fundamental aspects that may affect arc generation and duration. This sample was known as the “Mock Cell” sample. The cells in the Mock Cell sample are geometrically similar to the ISS cells. However, each cell is made of copper instead of the semi-conducting material used in the ISS coupon. The Mock Cell coupon provided flexibility in the geometric arrangement of the individual cells. Thus, the gap between cells, as well as the distance between the cell and the substrate, could be easily modified. A drawing as well as a picture of the Mock Cell coupon is shown in Figure 8.

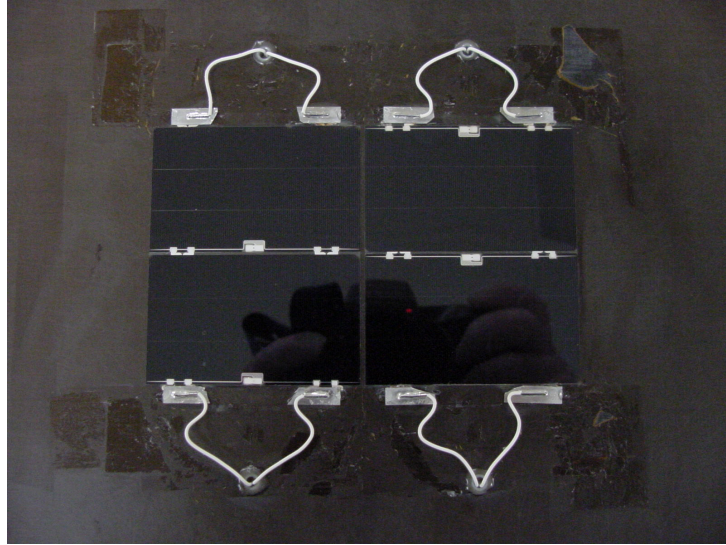

**Figure 6. Picture of the Planar TECSTAR sample.**

Regardless of the particular test coupon used, each sample shared the following characteristics: 1) The samples were mounted on top of a Kapton film substrate, 2) Each sample had a conductive region (typically photovoltaic semiconductors) that was exposed to the plasma, and 3) All of the solar cell modules had coverglass on top of the cell material. In most cases the coverglass sheet extended beyond the cell material. For example, in the ISS coupon the coverglass sheet overhang was a few mils (1 mil=1/1000 inch).



**Figure 7. Picture of the Tecstar Concentrator sample.**

Although the number of samples tested was relatively small, to accurately complete the assessment of the array, hundreds of arc events were required. To facilitate the process of creating an arc and capturing arc current and voltage information, a computerized control and acquisition system was assembled. A LabView™ program was created to control a personal computer equipped with a data acquisition card and an IEEE-488 card. The control system set the trigger arc power supply voltage and operated the switch attached to the differential power supply. An arc detection circuit was created to sense the initiation of a trigger arc. This circuit

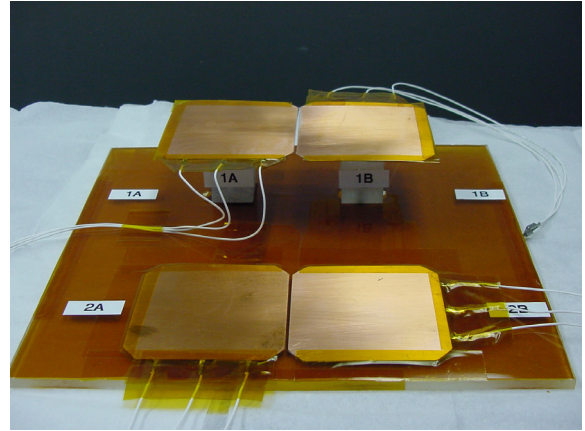
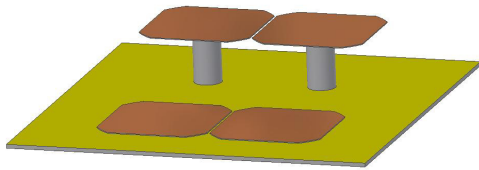

Figure 8. Drawing of the Mock Cell coupon (left). Picture of the test sample (right).

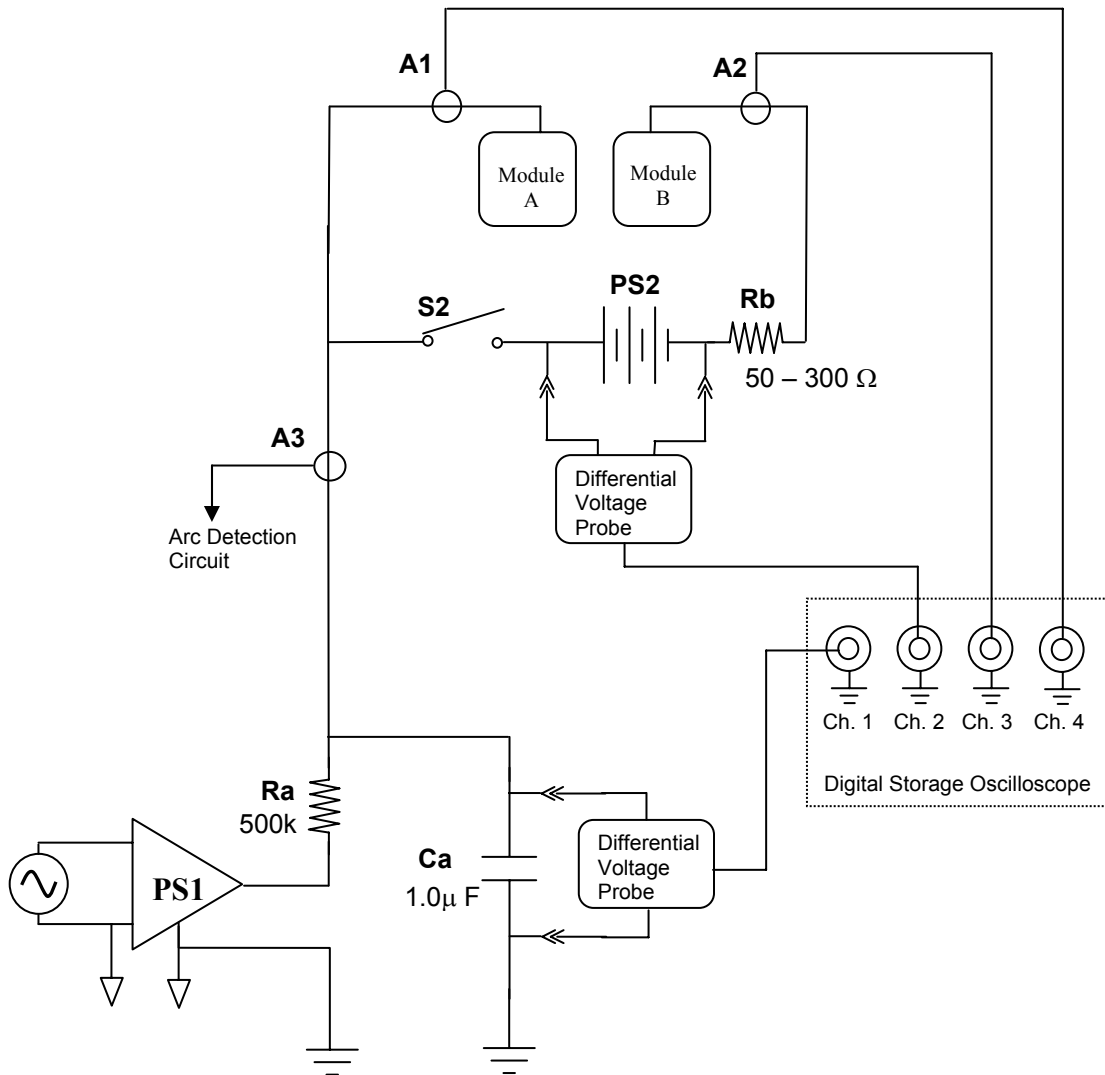

Figure 9. Schematic diagram of the components used to generate sustained arcs.



provided a pulse to the computer which shut down the power supplies and automatically transferred the current and voltage data from a digital storage oscilloscope to the computer. The LabView™ program then created an arc log file which contained information about the sample under test as well as the elapsed time between the application of power to the array to the detection of an arc. Figure 9 shows the arrangement of equipment used to conduct the tests.

### Test Results

The trigger arc voltage threshold is a key parameter in determining whether or not an array technology is suitable for use as a high voltage source in a plasma environment. To determine the voltage at which a trigger arc would occur, a specific procedure was created. This procedure is captured in Figure 10. The current and voltage waveforms are captured for each arc event. A typical set of trigger arc waveforms is shown in Figure 11. Recall, a trigger arc is characterized by a very short duration with a large current peak. The results of the trigger arc tests conducted on the three array technologies are tabulated in Figure 12.

Upon completion of the trigger arc threshold tests, the next step was to determine the conditions necessary to generate a sustained arc. Although a given technology may have had a relatively low trigger arc threshold, it is still useful to study the sustained arc properties of the array to determine which technology is the least susceptible to long duration arcs.

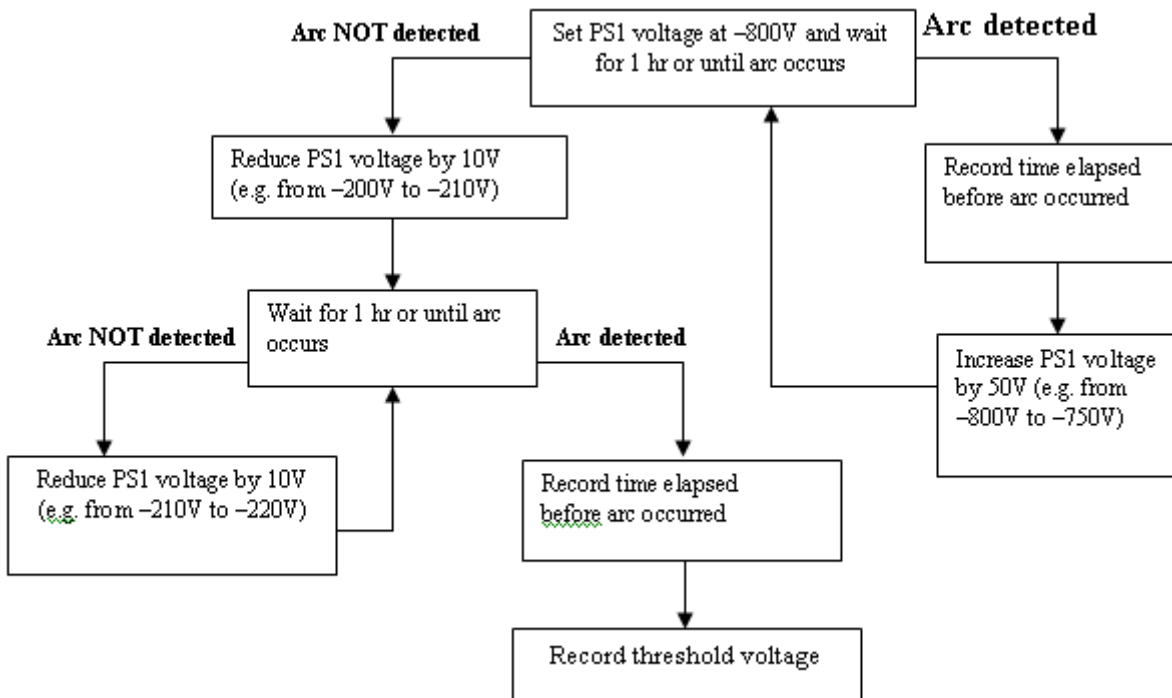

**Figure 10. Procedure used to establish the trigger arc threshold.**

The circuit shown in Figure 9 above is used to generate a sustained arc. An important part of the sustained arc circuit is the resistor (Rb) attached to the differential power supply. This series resistance is used to limit the current flow from the differential supply. This resistor was changed based on the voltage setting of the differential supply. By limiting the current from the differential supply (typically <3 amps), a more realistic simulation is created of the current available in a full array string. Typical sustained arc current and voltage waveforms are shown in Figure 13. Note the long duration time and low average current values, characteristic of a sustained arc.

During the course of a sustained arc test, the differential voltage and current levels are changed in order to survey the conditions that lead to damaging sustained arcs. By scanning the parameter space in this way, it is possible to determine voltage, current, and power thresholds for the generation of a sustained arc. Understanding these thresholds is key to designing a new solar array technology that is immune to sustained arcs. Figure 14 shows the sustained arc thresholds for two different array technologies.

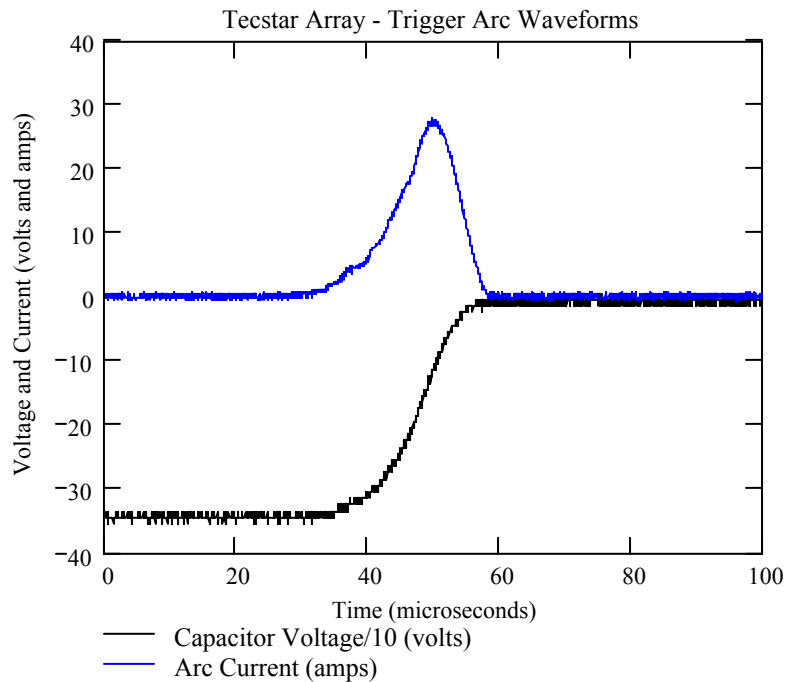

**Figure 11. Representative trigger arc waveforms.**

At the completion of the sustained arc testing of the solar array technologies selected by the D2HET program, a unique opportunity existed to create a custom solar array coupon which could be used to better understand some of the factors that contribute to the duration of sustained arcs. By creating a “Mock Cell” coupon, it was possible to focus on the role of substrate materials in sustained arc duration. One might imagine that heating of the substrate material leads to the release of neutral particles from the surface, through evaporation or even ablation. Depending on the rate with which these neutrals are released into the discharge, the local ionization rate, and the rate with which electrons are released from the conducting materials, the duration of the arc may change significantly. To explore this possibility, a Mock Cell sample

was created with two sets of “cell” pairs. One set of cells was placed “flat” against the Kapton substrate as is commonly found on commercial arrays. The other set of cells was “elevated” 5 cm above the Kapton substrate. Figure 8 above shows the arrangement of the cells in the Mock Cell coupon.

**Trigger arc threshold results for ISS coupon.**

Date of test: 25/2003		Date of test: 2/26/2003	
Applied Voltage (V)	Time elapsed before arc (min)	Applied Voltage (V)	Time elapsed before arc (min)
-500	0.159	-400	9.981
-450	1.629	-350	60.001
-400	24.985	-360	60.001
-350	60	-370	10.979
-360	60.001	-400	27.474
-370	49.416	-350	60.001
		-360	34.361

**Trigger arc threshold results for TECSTAR planar coupon.**

Date of test: 4/7/2003		Date of test: 4/8//2003	
Applied Voltage (V)	Time elapsed before arc (min)	Applied Voltage (V)	Time elapsed before arc (min)
-400	1.059	-250	12.636
-350	0.507	-200	60.001
-300	19.618	-210	54.448
-250	28.504		
-200	60.001		
-210	24.885		

**Trigger arc threshold results for TECSTAR concentrator coupon.**

Date of test: 5/5/2003	
Applied Voltage (V)	Time elapsed before arc (min)
-400	0.013
-350	0.024
-300	0.059
-250	0.266
-200	60.001
-210	0.874

**Figure 12. Results of the trigger arc threshold tests.**

Sustained arc tests were conducted on the Mock Cell coupon. The results are shown in Figure 15. It is clearly evident for this coupon that the elevated cells produced dramatically extended arc times. In some cases arcs in the elevated set sustained for one order of magnitude more than in the flat set. While this result is certainly interesting, more tests are required to rule

out the effect of factors such as variations in cell material composition or workmanship differences. Certainly if the substrate material is found to play a role in arc sustainment, spacecraft designers would have a new option for controlling or eliminating sustained arcs.

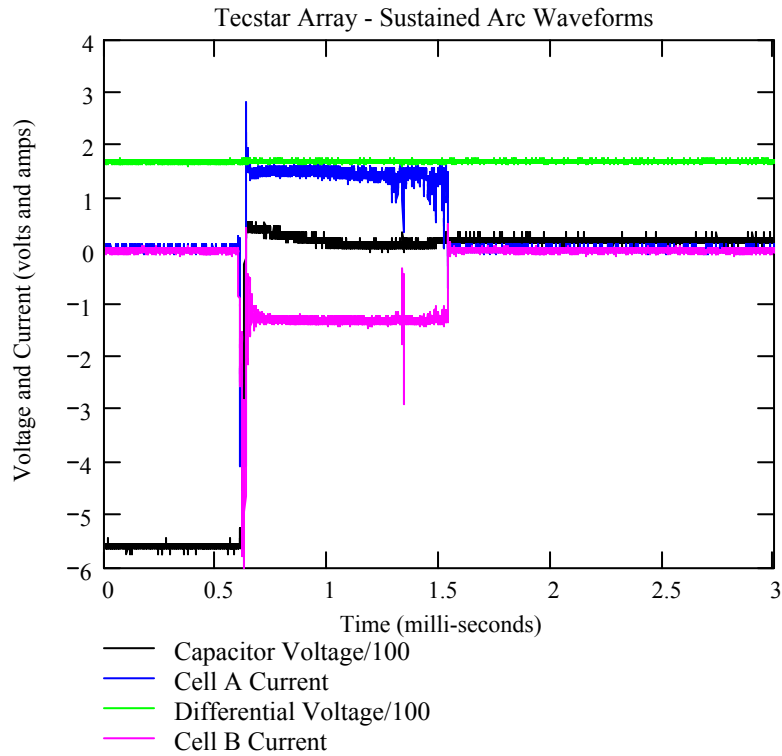

**Figure 13. Representative sustained arc waveforms.**

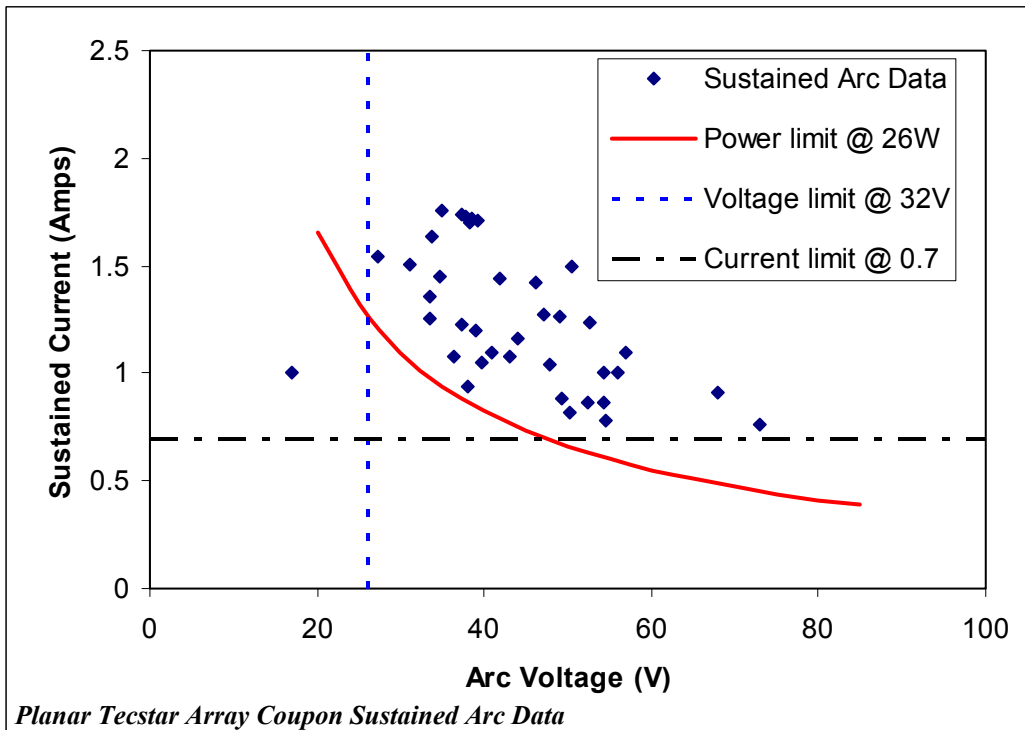
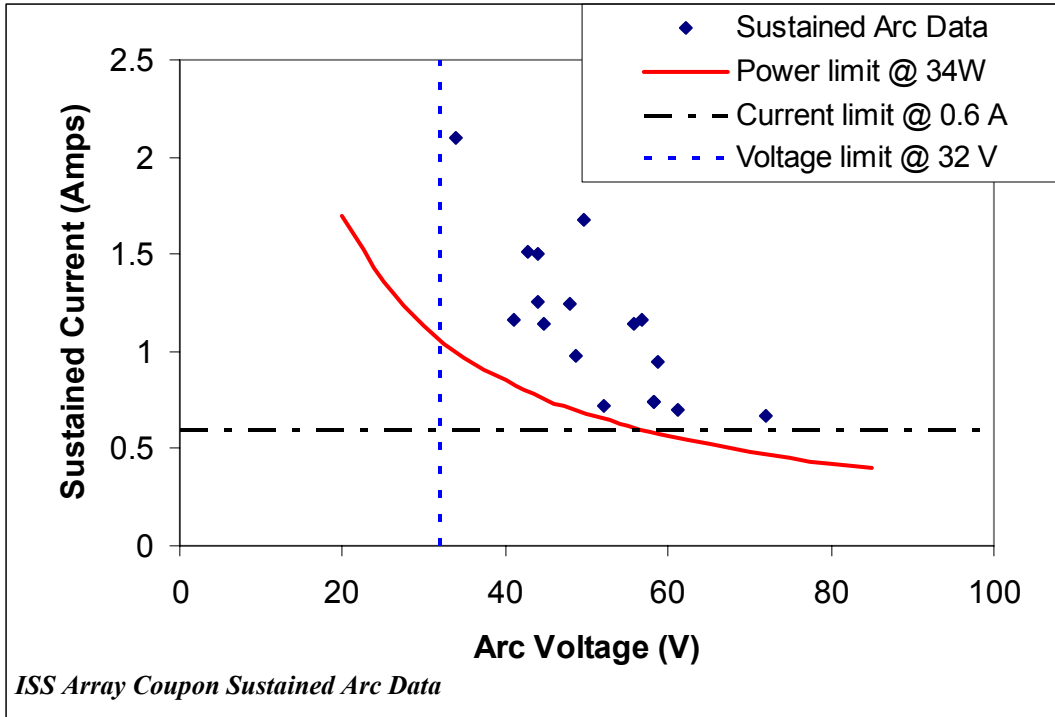

**Figure 14. Current, Voltage, and Power thresholds for the ISS array (top) and the Planar Tecstar array (bottom)**

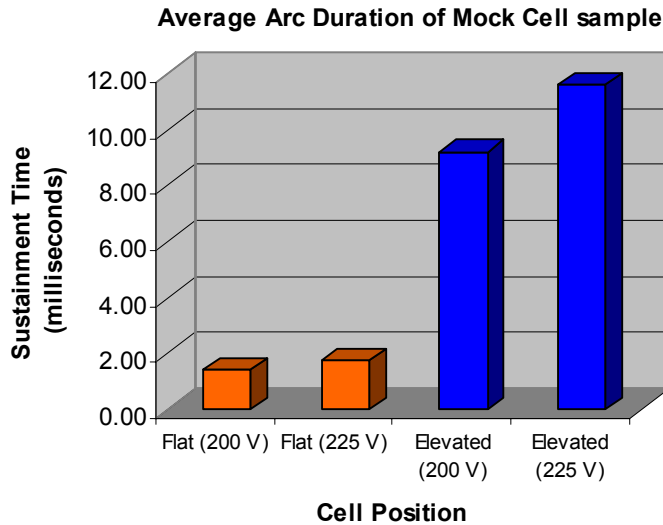

**Figure 15. Results of the trigger arc threshold tests.**

### Conclusion

A set of tests has been completed which assess the susceptibility of some existing solar array technologies to arc when biased at high negative potentials in a plasma environment. The tests were broken into two broad categories: Trigger Arc tests and Sustained Arc tests. In the Trigger Arc tests, arc voltage thresholds were established for each array technology. In the sustained arc tests, voltage, current, and power thresholds were determined for two of the three solar array technologies. In addition to the tests conducted with commercially available array segments, a separate sustained arc test was conducted on a custom built Mock Cell sample. Results of the Mock Cell sample indicated the possibility that the substrate material that is in contact with the solar cells may play a role in the arc duration.

All of the tests described in this paper were conducted as a part of the Direct Drive Hall-Effect Thruster (D2HET) program. The D2HET program requires the use of high voltage (300 volt) solar arrays to directly supply the anode voltage for a Hall-effect thruster. This requirement is challenging due to the fact that the arrays will be immersed in a plasma. To ensure long solar array lifetimes it is important to minimize or eliminate arcing. None of the array technologies tested met the demands of the D2HET program. However, all of the tests combined to create a dataset that includes voltage, current, and power thresholds for arc generation. This dataset is being used to create a new solar array sample which is expected to operate at -300 volts without generating a sustained arc. The new sample is scheduled to be tested in early 2004. It is hoped that the new solar array technology will be useful not only for a D2HET mission, but also for any spacecraft designer that is interested in increasing array voltages without incurring spacecraft charging problems.

### Acknowledgement

The authors wish to thank Mr. Ed Watts for his valuable assistance in gathering the arc data.

## References

- 
- <sup>1</sup> Carruth, M.R., et al., “ISS and Space Environment Interactions Without Operating Plasma Contactor”, 39<sup>th</sup> AIAA Aerospace Sciences Meeting, Reno, NV, January 2001, AIAA-2001-0401.
  - <sup>2</sup> Hastings, D.E., “A review of plasma interactions with spacecraft in low Earth orbit,” Journal of Geophysical Research, Vol. 100, No. A8, Pages 14,457-14,483, August 1, 1995.
  - <sup>3</sup> Hikita, M. and Cho, M., “Charging and Discharging Phenomena in Simulated Space Environment,” IEEE 19th Int. Symp. on Discharges and Electrical Insulation in Vacuum, 0-7803-5791-4/00, Xi’an, 2000.
  - <sup>4</sup> Hoskins, W.A., et al. “Direct Drive Hall Thruster System Study”, 51st JANNAF Propulsion Meeting, Orlando, Florida, 19-21 November 2002.
  - <sup>5</sup> Oleson, S.R. and Sankovic, J.M., “Advanced Hall Electric Propulsion for Future In-Space Transportation,” NASA TM-2001-210676, April 2001.
  - <sup>6</sup> Mikellides, I.G., et al. “Assessment of High-Voltage Solar Array Concepts for a Direct Drive Hall Effect Thruster System”, 39<sup>th</sup> AIAA/ASME/SAE/ASEE Joint Propulsion Conference, Huntsville, Alabama, 20-23 July 2003.
  - <sup>7</sup> Davis, S., Stillwell, R., Andlario, W., Snyder, D., and Katz, I., EOS-AM Solar Array Arc Mitigation Design, SAE Technical Paper 1999-01-2582, August, 1999.
  - <sup>8</sup> Cho, M., et al., “Laboratory Tests on 110-Volt Solar Arrays in Ion Thruster Plasma Environment”, Journal of Spacecraft and Rockets, Vol. 40, No. 2, March–April 2003
  - <sup>9</sup> Jongeward, G.A., et al., “Development of a Direct Drive Hall Effect Thruster System”, SAE Power Systems Conference, Paper No. 02PSC-77, Coral Springs, Florida, 29-31 October 2002.
  - <sup>10</sup> Hastings, D.E., Cho, M., and Kuninaka, H., “Arcing rates for a high voltage solar array: Theory, experiment and predictions,” J.Spacecraft and Rockets, Vol.29, No.4, 1992., pp.538-554.
  - <sup>11</sup> Ferguson, D.C., et al., “High Voltage Space Solar Arrays,” 53rd International Astronautical Congress, The World Space Congress – 2002, IAC-02-IAA.6.3.03, 10-19 Oct 2002.
  - <sup>12</sup> The sample was manufactured by Tecstar, Inc., City of Industry, California.