

NASA/CR-2004-208944



***Advanced Life Support Research and Technology  
Development Metric – Fiscal Year 2004***

A. J. Hanford, Ph.D.  
*Lockheed Martin Space Operations  
Houston, Texas 77058*

## THE NASA STI PROGRAM OFFICE . . . IN PROFILE

Since its founding, NASA has been dedicated to the advancement of aeronautics and space science. The NASA Scientific and Technical Information (STI) Program Office plays a key part in helping NASA maintain this important role.

The NASA STI Program Office is operated by Langley Research Center, the lead center for NASA's scientific and technical information. The NASA STI Program Office provides access to the NASA STI Database, the largest collection of aeronautical and space science STI in the world. The Program Office is also NASA's institutional mechanism for disseminating the results of its research and development activities. These results are published by NASA in the NASA STI Report Series, which includes the following report types:

- **TECHNICAL PUBLICATION.** Reports of completed research or a major significant phase of research that present the results of NASA programs and include extensive data or theoretical analysis. Includes compilations of significant scientific and technical data and information deemed to be of continuing reference value. NASA's counterpart of peer-reviewed formal professional papers but has less stringent limitations on manuscript length and extent of graphic presentations.
- **TECHNICAL MEMORANDUM.** Scientific and technical findings that are preliminary or of specialized interest, e.g., quick release reports, working papers, and bibliographies that contain minimal annotation. Does not contain extensive analysis.
- **CONTRACTOR REPORT.** Scientific and technical findings by NASA-sponsored contractors and grantees.
- **CONFERENCE PUBLICATION.** Collected papers from scientific and technical conferences, symposia, seminars, or other meetings sponsored or cosponsored by NASA.
- **SPECIAL PUBLICATION.** Scientific, technical, or historical information from NASA programs, projects, and mission, often concerned with subjects having substantial public interest.
- **TECHNICAL TRANSLATION.** English-language translations of foreign scientific and technical material pertinent to NASA's mission.

Specialized services that complement the STI Program Office's diverse offerings include creating custom thesauri, building customized databases, organizing and publishing research results . . . even providing videos.

For more information about the NASA STI Program Office, see the following:

- Access the NASA STI Program Home Page at <http://www.sti.nasa.gov>
- E-mail your question via the Internet to [help@sti.nasa.gov](mailto:help@sti.nasa.gov)
- Fax your question to the NASA Access Help Desk at (301) 621-0134
- Telephone the NASA Access Help Desk at (301) 621-0390
- Write to:  
NASA Access Help Desk  
NASA Center for AeroSpace Information  
7121 Standard  
Hanover, MD 21076-1320

NASA/CR-2004-208944



***Advanced Life Support Research and Technology  
Development Metric – Fiscal Year 2004***

A. J. Hanford, Ph.D.  
*Lockheed Martin Space Operations  
Houston, Texas 77058*

Available from:

NASA Center for AeroSpace Information  
7121 Standard Drive  
Hanover, MD 21076-1320

National Technical Information Service  
5285 Port Royal Road  
Springfield, VA 22161

This report is also available in electronic form at <http://ston.jsc.nasa.gov/collections/TRS>

# Contents

<b>1</b>	<b>INTRODUCTION.....</b>	<b>1</b>
1.1	EXECUTIVE SYNOPSIS.....	1
1.2	BASIC METRIC FORMAT .....	1
1.3	DESCRIPTION OF EQUIVALENT SYSTEM MASS.....	2
1.4	PREVIOUS ADVANCED LIFE SUPPORT METRIC COMPUTATIONS .....	2
1.5	NOTES ON THE METRIC FOR FISCAL YEAR 2004.....	3
1.6	CONTROL AND CONTACT INFORMATION .....	4
<b>2</b>	<b>BACKGROUND .....</b>	<b>5</b>
2.1	SUPPORTING DOCUMENTATION .....	5
2.2	REFERENCE MISSIONS .....	5
2.2.1	<i>ORBITING RESEARCH FACILITY: INTERNATIONAL SPACE STATION UPGRADE MISSION.....</i>	<i>5</i>
2.2.2	<i>INDEPENDENT EXPLORATION MISSION: MARS DUAL LANDER ARCHITECTURE.....</i>	<i>6</i>
2.3	METRIC ASSUMPTIONS .....	6
2.4	TECHNOLOGY ASSUMPTIONS.....	7
2.4.1	<i>ORBITING RESEARCH FACILITY: INTERNATIONAL SPACE STATION UPGRADE MISSION.....</i>	<i>7</i>
2.4.2	<i>INDEPENDENT EXPLORATION MISSION: MARS TRANSIT VEHICLE.....</i>	<i>13</i>
2.4.3	<i>INDEPENDENT EXPLORATION MISSION: MARS DESCENT / ASCENT LANDER.....</i>	<i>18</i>
2.4.4	<i>INDEPENDENT EXPLORATION MISSION: SURFACE HABITAT LANDER.....</i>	<i>23</i>
2.4.5	<i>MISSION PARAMETERS .....</i>	<i>29</i>
2.4.6	<i>INFRASTRUCTURE COSTS/EQUIVALENCIES.....</i>	<i>33</i>
<b>3</b>	<b>ADVANCED LIFE SUPPORT RESEARCH AND TECHNOLOGY DEVELOPMENT METRIC .....</b>	<b>34</b>
3.1	SUBSYSTEM TECHNOLOGY DATA.....	34
3.2	ADVANCED LIFE SUPPORT RESEARCH AND TECHNOLOGY DEVELOPMENT METRIC .....	38
3.2.1	<i>METRIC VALUES .....</i>	<i>38</i>
3.2.2	<i>DISCUSSION .....</i>	<i>38</i>
3.3	METRIC REPORTING RECOMMENDATIONS.....	39
3.3.1	<i>METRIC RECOMMENDATION FOR FISCAL YEAR 2004 .....</i>	<i>39</i>
3.3.2	<i>COMPARISON WITH PAST ASSESSMENTS .....</i>	<i>39</i>
<b>4</b>	<b>CAUTIONS AND DISCLAIMERS.....</b>	<b>43</b>
<b>5</b>	<b>SPECIAL RECOGNITION OF WORK .....</b>	<b>43</b>
<b>6</b>	<b>REFERENCES .....</b>	<b>44</b>
<b>7</b>	<b>ABBREVIATIONS AND ACRONYMS .....</b>	<b>45</b>

## Tables

Table 1.2.1	Technology Readiness Levels.....	2
Table 2.4.1	Advanced Mission Parameters.....	29
Table 2.4.2	Specific Input Values for Metric Mission Parameters .....	30
Table 2.4.3	Advanced Mission Cost Equivalencies.....	33
Table 3.1.1	Orbiting Research Facility: International Space Station Upgrade Mission using ISS ECLSS Technologies.....	34
Table 3.1.2	Orbiting Research Facility: International Space Station Upgrade Mission using ALS Technologies.....	34
Table 3.1.3	Independent Exploration Mission: Mars Transit Vehicle using ISS ECLSS Technologies.....	35
Table 3.1.4	Independent Exploration Mission: Mars Transit Vehicle using ALS Technologies.....	35
Table 3.1.5	Independent Exploration Mission: Mars Descent / Ascent Lander using ISS ECLSS Technologies.....	36
Table 3.1.6	Independent Exploration Mission: Mars Descent / Ascent Lander using ALS Technologies .....	36
Table 3.1.7	Independent Exploration Mission: Surface Habitat Lander using ISS ECLSS Technologies .....	37
Table 3.1.8	Independent Exploration Mission: Surface Habitat Lander using ALS Technologies .....	37
Table 3.2.1	Equivalent System Mass and Metric Values for a Range of Missions and Technologies .....	38
Table 3.3.1	Previous Advanced Life Support Research and Technology Development Metric Values.....	39

## Figures

Figure 2.4.1	International Space Station Upgrade Mission using ISS ECLSS Baseline Technologies. ....	11
Figure 2.4.2	International Space Station Upgrade Mission using ALS Technologies. ....	12
Figure 2.4.3	Mars Transit Vehicle using ISS ECLSS Baseline Technologies. ....	16
Figure 2.4.4	Mars Transit Vehicle using ALS Technologies. ....	17
Figure 2.4.5	Mars Descent / Ascent Lander using ISS ECLSS Baseline Technologies.....	21
Figure 2.4.6	Mars Descent / Ascent Lander using ALS Technologies. ....	22
Figure 2.4.7	Surface Habitat Lander using ISS ECLSS Baseline Technologies.....	27
Figure 2.4.8	Surface Habitat Lander using ALS Technologies.....	28
Figure 3.3.1	Equivalent system mass summary for the Fiscal Year 2004 ALS Research and Technology Development Metric missions and technology suites. ....	40
Figure 3.3.2	Equivalent system mass summary for the components of the Independent Exploration Mission. ....	41
Figure 3.3.3	Historical progression of Advanced Life Support Research and Technology Development Metric values as a function of fiscal year. ....	42

# 1 INTRODUCTION

This document provides the official calculation of the Advanced Life Support (ALS) Research and Technology Development Metric (the Metric) for Fiscal Year 2004. As such, the values herein are primarily based on Systems Integration, Modeling, and Analysis (SIMA) Element approved software tools or reviewed and approved reference documents.

## 1.1 EXECUTIVE SYNOPSIS

For Fiscal Year 2004, the Advanced Life Support Research and Technology Development Metric value is 2.03 for an Orbiting Research Facility and 1.62 for an Independent Exploration Mission.

## 1.2 BASIC METRIC FORMAT

The Metric is one of several measures employed by the National Aeronautics and Space Administration (NASA) to assess the Agency's progress as mandated by the United States Congress and the Office of Management and Budget. Because any measure must have a reference point, whether explicitly defined or implied, the Metric is a comparison between a selected ALS Project life support system and an equivalently detailed life support system using technology from the Environmental Control and Life Support System (ECLSS) for the International Space Station (ISS). More specifically, the Metric is the ratio defined by the equivalent system mass (ESM) of a life support system for a specific mission using the ISS ECLSS technologies divided by the ESM for an equivalent life support system using the "best" ALS technologies.

As defined, the Metric should increase in value as the ALS technologies become lighter, less power intensive, and require less volume. Here "best" is defined as the ALS configuration that, at the time of the Metric evaluation, provides the Metric with the highest value. This process theoretically encourages the ALS Project to research more than a single technology for each life support function and then select the most appropriate for a particular mission, which is similar to the actual process used by mission planners. Only technologies of a certain maturity level, generally of technology readiness level of 5 or higher, are selected for inclusion in the Metric to avoid assuming too much with too little data. Some promising advanced technologies at a lower technology readiness level might appear here, but those selections should be uncommon. See Table 1.2.1 for a summary of the technology readiness levels used by NASA (Henninger, *et al.*, 2002). This implies that the Metric will improve as promising technologies mature within the ALS Project and become eligible for inclusion in this calculation. Conversely, early assumptions for some technologies may be overly optimistic, so the Metric value using those technologies may decrease in the future as additional research uncovers higher than expected costs and outdated assumptions are revised.

**Table 1.2.1 Technology Readiness Levels**

<b>Technology Readiness Level</b>	<b>Description</b>
1	Basic principles observed and reported.
2	Technology Concept and/or application formulated.
3	Analytical and experimental critical function and/or characteristic proof-of-concept.
4	Component and/or breadboard validation in laboratory environment.
5	Component and/or breadboard validation in relevant environment.
6	System/subsystem model or prototype demonstration in relevant environment (ground or space).
7	System prototype demonstration in a space environment.
8	Actual system completed and “flight qualified” through test and demonstration.
9	Actual system “flight proven” through successful mission operations.

### **1.3 DESCRIPTION OF EQUIVALENT SYSTEM MASS**

Equivalent system mass (ESM) is the sum of the masses of life support equipment and supplied commodities, plus the mass penalties for infrastructure support, notably power, volume, and cooling, corrected for the crewtime required to operate and maintain the life support system. See Levri, *et al.*, 2003.

ESM reduces the physical quantities describing a system or subsystem to use a single physical parameter: mass. This allows comparison of two systems with different physical parameters using a single scalar, and avoids the necessity of arbitrary weightings that reflect the prejudices of the analyst to compare, for example, a lighter subsystem to one using less power.

Conversion factors, or equivalencies, are determined for the environment and infrastructure technologies that are likely to be used for a mission. For systems requiring power, for example, examination of the power system can yield an appropriate power-mass penalty by dividing the average power-plant output for user loads by the total mass of the generating power system. Thus, for a nuclear power system on an independent lander that, on average, delivers 100 kW of electrical user power and has an overall mass of 8,708 kg, the power-mass penalty is 87 kg/kW (0.0115 kW/kg) (Hanford, 2004). This power-mass penalty effectively assigns a fraction of the power system mass to a power-using subsystem in place of that subsystem’s power requirement. In like manner, mass penalties to account for heat rejection, called cooling here, and volume within a pressurized shell are defined.

### **1.4 PREVIOUS ADVANCED LIFE SUPPORT METRIC COMPUTATIONS**

Previously released Metric computations, in reverse chronological order, may be found in the documents listed below.<sup>1</sup>

Hanford, A. J. (2003) “Advanced Life Support Research and Technology Development Metric – Fiscal Year 2003,” NASA/CR-2004-208939 (JSC 60455, CTSD-ADV-524), National Aeronautics and Space Administration, Lyndon B. Johnson Space Center, Houston, Texas, 30 September 2003.

Hanford, A. J. (2003) “Advanced Life Support Research and Technology Development Metric – Fiscal Year 2002,” JSC 60313 (CTSD-ADV-510), Revision A, National Aeronautics and Space Administration, Lyndon B. Johnson Space Center, Houston, Texas, 24 July 2003.

---

<sup>1</sup> For electronic copies of recent documents, please see <http://advlifesupport.jsc.nasa.gov/>.



Hanford, A. J. (2003) “Advanced Life Support Research and Technology Development Metric – Fiscal Year 2002,” JSC 60313 (CTSD-ADV-510), National Aeronautics and Space Administration, Lyndon B. Johnson Space Center, Houston, Texas, 15 January 2003.

Drysdale, A. E., and Hanford, A. J. (2002) “Advanced Life Support Research and Technology Development Metric – Fiscal Year 2001,” JSC 47787 (CTSD-ADV-482), National Aeronautics and Space Administration, Lyndon B. Johnson Space Center, Houston, Texas, 17 January 2002.

Drysdale, A. E. (2001) “Update to the Advanced Life Support Research and Technology Development Metric,” National Aeronautics and Space Administration, Lyndon B. Johnson Space Center, Houston, Texas, 19 February 2001.

Drysdale, A. E., and Hanford, A. J. (1999) “Advanced Life Support Research and Technology Development Metric – Baseline” JSC 39503 (CTSD-ADV-384), National Aeronautics and Space Administration, Lyndon B. Johnson Space Center, Houston, Texas, 19 November 1999.

Hanford, A. J., and Drysdale, A. E. (1999) “Advanced Life Support Technology Research and Development Metric – Initial Draft,” LMSMSS 33045, Lockheed Martin Space Mission Systems and Services, Houston, Texas, 13 January 1999.

## 1.5 NOTES ON THE METRIC FOR FISCAL YEAR 2004

The ALS Project continues to evolve and change both in structure and focus, and these changes affect the Metric, some more strongly than others. For the current calculation, the differences in approach and organization from Fiscal Year 2003, Hanford (2003b), are minimal. Most importantly, the current calculation uses a revised version of a generalized life support spreadsheet tool, the Advanced Life Support Sizing Analysis Tool (ALSSAT) (Yeh, *et al.*, 2002, Yeh, *et al.*, 2003, and Yeh, *et al.*, 2004). ALSSAT provided values to the current Metric calculation for all subsystems and applicable external interfaces.

Previous Metric calculations (See, for example, Drysdale and Hanford, 2002) and SIMA’s official definition (See, Levri, *et al.*, 2003) include crewtime as part of equivalent mass assessments. This year, ALSSAT includes crewtime in assessments, when data is available, addressing a deviation from the approach used in 2003 (Hanford, 2003b).

ALSSAT underwent a number of changes internally that impact the Metric, as detailed in Yeh, *et al.* (2004). These updates affect many technologies within ALSSAT in some manner, but numerical impacts of those changes on the Metric are not individually apparent at this time. Of note, this year’s efforts updated values for Sabatier and several other technologies. While ALSSAT continues to evolve and improve, it is believed that the current computations are sufficiently accurate to provide credible Metric values for Fiscal Year 2004.

To be consistent with last year and to reflect advances in thermal rejection technologies, the current Metric calculations apply different cooling-mass penalties to the different life support system configuration assessments for exploration mission vehicles. Cooling-mass penalties, assuming aluminum, flow-through radiators, apply this year to life support system assessments using hardware from the ISS ECLSS technology suite. Cooling-mass penalties for life support system assessments based on the ALS technology suite assume advanced hardware using composite heat-rejection technologies. This is consistent with the previous calculation (Hanford, 2003b). This current Metric calculation, then, showcases advantages associated with advanced thermal rejection technologies developed with ALS Project funding, providing appropriate reduced cooling-mass penalties for ALS configurations.

Finally, a Metric workshop near the end of Fiscal Year 2003 brought together analysts and management at all levels of NASA to consider the future of the Metric. Several changes from the discussions in that forum are included in this year’s calculation. The most significant are listed here.

- Changes to the Metric will be listed or referenced in this document. Specifically, changes to the approach, methodology, or life support architecture are listed in this document, while changes to the calculation tool, ALSSAT, are recorded in software specific documentation. (See Yeh, *et al.*, 2004.) However, while subjective, factors of “great influence” to the Metric related to ALSSAT are listed here.

- Dry food mass is excluded from the life support system for both current and advanced architectures.
- Infrastructure equivalencies could vary over time. The infrastructure values used for this calculation appear in Hanford (2004) and are unchanged from the previous calculation (Hanford, 2003b).
- ALSSAT does not include stowage factors<sup>2</sup> for all technologies, and this is a deviation from Levri, *et al.* (2003). More specifically, ALSSAT provides all technologies on a common basis. To date, secondary structures, or stowage factors, are included for the Sabatier carbon dioxide reduction assembly, although the carbon dioxide compressor assembly physical properties are neglected. The carbon dioxide removal hardware and the gas storage hardware also include secondary structures. All other hardware neglects secondary structures.
- Data for all technologies selected in this year's assessments are thought to correspond to a technology readiness level (TRL) of 5 or greater.
- ALSSAT now tracks crewtime for individual technologies. These values are included in the assessments below and are included in the overall equivalent system mass values. Crewtime data for all ALSSAT technologies may be incomplete at this time.
- ALSSAT now computes the crew metabolic waste stream as feces, urine, respiration, and perspiration based on metabolic intake, compared with using average values from Hanford (2004).
- ALSSAT tracks thermal loads separately from power consumption, thus removing the simplifying assumption that thermal load is equivalent to power consumption. Thermal data for all ALSSAT technologies may be incomplete at this time. When unknown, the thermal load is still assumed equal to the power consumption.

## 1.6 CONTROL AND CONTACT INFORMATION

The ALS Project controls the Metric, and SIMA provides the Metric calculation. Subsequent releases will be made as required. Please forward comments to:

Mr. Michael K. Ewert  
 Manager, Systems Integration, Modeling, and Analysis Element  
 Advanced Life Support Project  
 National Aeronautics and Space Administration  
 Lyndon B. Johnson Space Center  
 Mail Code EC2  
 2101 NASA Parkway  
 Houston, Texas 77058  
 E-mail: michael.k.ewert@nasa.gov

---

<sup>2</sup> Stowage factors account for necessary secondary structure to mount hardware inside the vehicle. This secondary structure differs from the primary vehicle structure, or hull, which is represented by the volume-mass penalty. See Hanford (2004) for details.

## 2 BACKGROUND

### 2.1 SUPPORTING DOCUMENTATION

The listed SIMA reference documents provided inputs for the Fiscal Year 2004 Advanced Life Support Research and Technology Development Metric calculation.<sup>3</sup>

Hanford, A. J., Editor (2004) "Advanced Life Support Baseline Values and Assumptions Document," NASA/CR-2004-208941, National Aeronautics and Space Administration, Lyndon B. Johnson Space Center, Houston, Texas.

Levri, J. A., Drysdale, A. E., Ewert, M. K., Fisher, J. W., Hanford, A. J., Hogan, J. A., Jones, H. W., Joshi, J. A., and Vaccari, D. A. (2003) "Advanced Life Support Equivalent System Mass Guidelines Document," NASA/TM-2003-212278, National Aeronautics and Space Administration, Ames Research Center, Moffett Field, California.

Stafford, K. W., Jerng, L. T., Drysdale, A. E., Maxwell, S., Levri, J. A., Ewert, M. K., and Hanford, A. J. (2001) "Advanced Life Support Systems Integration, Modeling, and Analysis Reference Missions Document," JSC 39502, Revision A, National Aeronautics and Space Administration, Lyndon B. Johnson Space Center, Houston, Texas.

Yeh, J., Brown, C., and Jeng, F. (2002) "Advanced Life Support Sizing Analysis Tool (ALSSAT) v.2.0 User's Guide," LMSEAT 34082, Lockheed Martin Space Operations, Houston, Texas.

Yeh, J., Brown, C., and Jeng, F. (2003) "Advanced Life Support Sizing Analysis Tool (ALSSAT) v.3.0," MSAD-03-0279, Lockheed Martin Space Operations, Houston, Texas.

Yeh, J., Brown, C., and Jeng, F. (2004) "FY04 ALSSAT Upgrade," MSAD-04-0261, Lockheed Martin Space Operations, Houston, Texas.

These reference documents provide the primary resources for the values contained below, and, unless noted otherwise, all values are listed in or derived from these documents.

### 2.2 REFERENCE MISSIONS

The following missions are addressed for Fiscal Year 2004:

- Orbiting Research Laboratory: International Space Station Upgrade Mission, and
- Independent Exploration Mission: Mars Dual Lander Architecture.

These missions are described briefly below. For additional details, see Stafford, *et al.* (2001).

The data given applies to nominal operations. Contingency planning, though extremely important, is not well advanced at this time for these missions, so contingencies are excluded from these calculations.

#### 2.2.1 ORBITING RESEARCH FACILITY: INTERNATIONAL SPACE STATION UPGRADE MISSION

The International Space Station (ISS) mission is a ten-year, six-crewmember<sup>4</sup> mission in low-Earth orbit. For this assessment, the specifics of Earth-to-orbit transfers are not considered, nor are ISS construction operations. Rather, this assessment considers just the ESM for nominal, on-orbit operation of

---

<sup>3</sup> For electronic copies of the NASA reference documents, please see <http://advlifesupport.jsc.nasa.gov/>.

<sup>4</sup> A crew of six is defined here not as a policy statement or a forward projection for NASA, but rather to make the ISS scenario comparable to other exploration missions that propose six crewmembers.

the life support system in the United States On-Orbit Segment (USOS) following Phase 3.<sup>5</sup> Extravehicular activities are assumed to be a small mission component during the day-to-day operation of the ISS after buildup is complete and are, therefore, omitted in the assessments here.<sup>6</sup>

The ISS Upgrade Mission follows the initial utilization phase for the complete vehicle and assumes that to use ISS for an additional ten-year mission the entire USOS life support system must be replaced with new equipment of the same or comparable technologies. This mission scenario, as addressed in the assessments below, assumes the cooling hardware will have identical properties to current ISS cooling hardware regardless of the life support system technologies used. The rationale for extending ISS beyond its initial design life is not addressed here but, rather, significant justification is implicitly assumed. Alternately, this mission might apply to a new space station of comparable size and capability that follows ISS in the timeframe indicated.<sup>7</sup>

The baseline equipment suite assumes an appropriate life support system for the USOS Phase 3 segment using ISS ECLSS technologies alone. This system includes newly fabricated equipment and it replaces the original equipment just prior to the beginning of the utilization phase of the ISS Upgrade Mission. The corresponding upgraded USOS life support system using ALS technologies provides the same capabilities as the ISS ECLSS USOS Phase 3 life support system but it employs the most economical, in terms of equivalent system mass, life support technologies regardless of origin.

## **2.2.2 INDEPENDENT EXPLORATION MISSION: MARS DUAL LANDER ARCHITECTURE**

This Mars exploration mission consists of a single trip to one site on Mars. The analysis assumes a standard mission profile with outbound and return transit segments of 180 days and a surface phase of 600 days (Stafford, *et al.*, 2001). Actual missions will vary in duration according to the year or transportation opportunity, propulsion capabilities, and mission development decisions.

A Mars Transit Vehicle carries the crew during both interplanetary segments, remaining dormant in Martian orbit while the crew descends to Mars for the surface phase. A second vehicle, the Mars Descent / Ascent Lander, will fly to Mars orbit robotically. The crew will transfer to, and land in, this second vehicle. A third vehicle, the Surface Habitat Lander, will fly to Mars and land robotically on the surface. This last vehicle will house the crew during the surface segment. During the surface segment, extravehicular activities will be frequent, if not daily, events. Here the extravehicular activities are assumed to occupy two crewmembers for up to 4 hours per sortie, with 700 sorties scheduled during surface operations from the Surface Habitat Lander. After completion of the surface phase, the crew will ascend to Martian orbit in the Mars Descent / Ascent Lander and rendezvous with the waiting Mars Transit Vehicle. Finally, each vehicle is optimized for either weightless or partial gravity, according to the primary operational environment. Thus, the Mars Transit Vehicle is studied while weightless, and the Surface Habitat Lander and the Mars Descent / Ascent Lander are assessed assuming partial gravity.

## **2.3 METRIC ASSUMPTIONS**

Except as may be noted here, all assumptions for the Metric are derived from the reference documentation above. The infrastructure, mission parameters, computational algorithms, and most of the overall assumptions are identical to the Fiscal Year 2003 Metric values (Hanford, 2003b). Any changes in assumptions most often arise directly or indirectly from changes and improvements in ALSSAT. See, in particular, Yeh, *et al.* (2004) for a summary of changes to ALSSAT for Fiscal Year 2004.

---

<sup>5</sup> Phase 3 is also known as “assembly complete.”

<sup>6</sup> While extravehicular activities, and the commodities they may use from the life support system are a concern, the scenario for extravehicular activities beyond assembly complete depends heavily on many factors beyond the scope of this current assessment, so rather than add questionable assumptions, “extravehicular activities are assumed to have a small but consistent impact on all life support system architectures, and may, therefore, be omitted.”

<sup>7</sup> While the ALS Project supports current NASA missions as requested, most ALS technologies under development will provide technological solutions for missions that are not yet defined because the technology-development cycle duration can be considerably longer than the mission-planning cycle duration. Thus, SIMA analyzes probable missions even if the specific rationale for a likely mission is not completely apparent.

The vehicles here assume a cabin volume, for purposes of computing cabin atmospheric parameters, based on the estimated structure for each vehicle. Based on Hanford (2004), all cabin volumes assure at least the minimal free volume for the crew. See Table 2.4.1.

To minimize the effect of infrastructure assumptions on the Metric value, similar infrastructures are assumed for each technology option. The International Space Station Upgrade Mission employs infrastructure values characteristic of International Space Station throughout, while the Mars Independent Exploration Mission assumes both current and advanced technologies with some inflatable modules. With respect to these latter vehicles, the structure penalties merely account for a pressurized volume and include no additional mass for environmental radiation protection, implying instead that life support equipment is naturally resistant to radiation hazards and crew interaction with life support equipment is minimal. The volume penalties for Mars Independent Exploration Mission vehicles do provide pressurized volume. See Table 2.4.3. These infrastructure values are identical to values assumed for the Fiscal Year 2003 Metric (Hanford, 2003b). See Hanford (2004) for details.

Support to extravehicular activities from the life support system, plus associated airlock operation costs, have been included. Extravehicular mobility units and other extravehicular activity equipment have not been included. As noted above, commodity losses for extravehicular activities are carried by the subsystem primarily concerned with that commodity and are not specifically identified as extravehicular activity support costs. Any costs associated with extravehicular activity support reflect equipment unique to that function.

Some life support system designs naturally recover more water than the crew uses to support their basic metabolic and hygiene requirements. Thus, such a surplus might be a resource for other vehicle systems just as fuel cell water is a resource from Shuttle to International Space Station. Any surplus water, however, has not been included in the official Fiscal Year 2004 calculations as an additional credit except as it may offset water usage elsewhere within the life support system.

Power and cooling infrastructure costs are estimated here using nominal power and cooling loads. This approach implies that peak loads have little impact on the power and cooling systems, or that these loads can be successfully averaged when considering the entire vehicle.

Finally, the computation for Fiscal Year 2004 assumes a single-string life support system architecture for all cases. Because different technologies may require differing levels of additional equipment to assure satisfactory redundancy and reliability for an actual flight configuration, this assumption may be a significant simplification in this computation.

## **2.4 TECHNOLOGY ASSUMPTIONS**

### ***2.4.1 ORBITING RESEARCH FACILITY: INTERNATIONAL SPACE STATION UPGRADE MISSION***

International Space Station uses aluminum modules and nodes pressurized to 101 kPa. Solar photovoltaic generation with rechargeable batteries for energy storage provide continuous power. The external thermal control system uses a single-phase, pumped ammonia loop to transport thermal energy and rejects the thermal loads using anti-sun tracking radiators with Z-93 surface coating. The ISS ECLSS hardware configuration associated with completion of Phase 3, or “assembly complete,” is the assumed baseline along with an additional mission duration of ten years. For this computation, extravehicular activities are not considered. Further, the ISS ECLSS provides 1.27 kg/d of potable water to payloads that is not recovered.<sup>8</sup> Table 2.4.2 details specific inputs for the ISS Upgrade Mission.

#### ***2.4.1.1 INTERNATIONAL SPACE STATION ENVIRONMENTAL CONTROL AND LIFE SUPPORT SYSTEM TECHNOLOGY BASELINE***

The ISS ECLSS, for the purposes of this document, is defined based on the USOS ECLSS scaled for a crew of six. See Stafford, *et al.* (2001), for details of the life support system architecture. This suite

---

<sup>8</sup> While this may seem wasteful, especially over a mission duration of ten years, payload wastewater may contain many constituents that the life support system’s water subsystem is not designed to handle adequately. Thus, rather than limit research on International Space Station only to experiments that generate compatible wastewater, and possibly jeopardize its overall research mission and/or the crew’s health through contaminating the water subsystem, it is prudent to simply dump this wastewater stream.

uses physicochemical technologies to regenerate air and water, while food is supplied as individual prepackaged entrees, including frozen food selections. Waste is stored without reclaiming any commodities. Thermal management employs coldplates and condensing heat exchangers to collect heat loads, a single-phase fluid to transport heat, and radiators to reject heat. Clothing is supplied from Earth clean and discarded to the waste subsystem once it is deemed too dirty to wear. See Figure 2.4.1.

#### 2.4.1.1.1 Air

The ISS ECLSS uses regenerable carbon dioxide removal equipment based on molecular sieve technology. The absorbed carbon dioxide is dumped overboard without recovering any commodities. The trace contaminant control system for atmospheric gases uses activated carbon, for non-combustible trace gas removal, and bacteria filter assemblies, for particulate removal, neither of which are regenerated. Further, the trace contaminant control system also removes trace combustible gases in the crew cabin. Oxygen is supplied both as pressurized gas from high-pressure stores, and as a product from electrolysis of water using solid polymer technology. The associated product hydrogen is dumped overboard. Electrolysis water is provided by the water subsystem. Nitrogen is supplied from high-pressure gas stocks. A major constituent analyzer and a fire detection and suppression system provide monitoring for air contaminants and combustion products.

#### 2.4.1.1.2 Food

Food is provided as individual entrees from Earth. A mix of fresh, dehydrated, and full-water preserved, shelf-stable, or frozen foods are used. This system provides significant quantities of water, but also requires significant quantities of packaging. Nominally, 11.82 MJ/CM-d of energy as food is supplied, corresponding to 1.372 kg/CM-d.<sup>9</sup> Neglecting the dry component, the food mass as-shipped is 0.707 kg/CM-d. In either case, 0.240 kg/CM-d of disposable packaging is required. The corresponding specialized food storage structure adds an additional 0.364 kg/CM-d. Supporting technology includes a freezer and some food preparation equipment.

#### 2.4.1.1.3 Thermal

Thermal management is divided into two systems here. The internal thermal control system includes the avionic air assemblies, which provide air-cooling for equipment, the common cabin air assemblies, which cool, dehumidify, and circulate cabin air, condensate storage, and the water flow loops for heat transport. Coldplates and heat exchangers are assumed part of other equipment, while the external thermal control system costs are assessed using the cooling-mass penalty.

#### 2.4.1.1.4 Waste

Solid waste is stored and returned aboard the crew transfer vehicle or burned upon re-entry in an expendable resupply vehicle. This includes trash, fecal material, brine from the urine and water processing, and used filters and cartridges. The toilet is also included here under the waste subsystem.

#### 2.4.1.1.5 Water

Urine is processed by vapor compression distillation. Eighty-eight percent water recovery is claimed. The brine is either returned to Earth or dumped. All grey water, including hygiene water, effluent from the vapor compression distillation, and condensate from dehumidification, is processed through a water processor. The water processor employs two multifiltration units, a volatile removal assembly, phase separators, and an ion exchange bed. A process control water quality monitor provides water quality assurance. Efficiency of recovery is high, but many expendables, mostly filter cartridges, are needed. Additional water may enter ISS directly, such as from the Shuttle's stock of fuel cell water or as moisture contained in food, or indirectly, as a human metabolic product from the consumption of supplied food. The first mechanism is not included while the second and third mechanisms are a natural part of the overall life support commodity mass balance. Lastly, water may also come from stocks, which is the assumed source of any additional water not contained either as food moisture or arising as metabolic products from food

---

<sup>9</sup> The units here, kilograms per crewmember per day [kg/CM-d], denote a per person basis.

consumption. Due to water losses for payloads, the ISS Upgrade Mission will probably be “water poor” in the nominal case without additional water stores.

#### 2.4.1.1.6 Human Accommodations

Clothing is delivered with the crew at the beginning of an expedition and returned to Earth with the crew at the end of each expedition. A usage rate of 0.486 kg/CM-d, in a volume of 0.00285 m<sup>3</sup>/CM-d, is assumed.

#### 2.4.1.2 *ADVANCED LIFE SUPPORT TECHNOLOGY*

In contrast to the architecture using the ISS ECLSS hardware, the ALS technology suite reduces accumulated atmospheric carbon dioxide with a Sabatier carbon dioxide reduction assembly and extracts water from waste using warm-air drying and lyophilization. Additionally, the ALS technology suite stores atmospheric gases as cryogenics, feeds the crew with an ambient temperature pre-packaged food system, and reclaims water using a vapor phase catalytic ammonia removal water recovery system. An aqueous laundry recycles crew clothing. See Figure 2.4.2.

##### 2.4.1.2.1 Air

The ALS suite uses a regenerable carbon dioxide removal assembly based on a four-bed molecular sieve technology, a Sabatier carbon dioxide reduction assembly with a gas stream compressor, and a trace contaminant control assembly based on ISS ECLSS technology. Adequate water is available to avoid a supply penalty for any necessary oxygen and hydrogen. Specifically, Sabatier reduces carbon dioxide according to the availability of hydrogen from the oxygen generation assembly. Any carbon dioxide that is not reduced is vented to space. High efficiency particulate air filters provide particulate removal. Gases for atmospheric pressurization, specifically oxygen and nitrogen, are stored under lower pressure as cryogenics compared to the high-pressure storage used within the ISS ECLSS suite. Other aspects of the ALS air suite are identical to the ISS ECLSS technology suite for air listed in Section 2.4.1.1.1.

##### 2.4.1.2.2 Food

The ALS suite for food employs ambient storage, prepackaged food with comparable nutritional content of 11.82 MJ/CM-d of metabolic energy. This food system provides 1.147 kg/CM-d of food, or 0.485 kg/CM-d of food moisture, as-shipped, if the dry food mass is neglected. 0.264 kg/CM-d of disposable packaging is required. The corresponding specialized food storage structure adds an additional 0.346 kg/CM-d. A freezer and refrigerator are unnecessary.

##### 2.4.1.2.3 Thermal

The ALS suite for the thermal subsystem uses the same technologies as the ISS ECLSS suite for the thermal subsystem described in Section 2.4.1.1.3.

##### 2.4.1.2.4 Waste

The ALS suite for waste uses warm-air drying and lyophilization, as appropriate, to recover water from solid wastes. Reclaimed water passes to the water subsystem to remove impurities. Dry, solid waste is compacted, stored, and finally returned to Earth for ultimate disposal.

##### 2.4.1.2.5 Water

The ALS suite for water recovery uses the vapor phase catalytic ammonia removal technology for primary water processing of both urine and grey water. Vapor phase catalytic ammonia removal uses distillation as its basic physicochemical mechanism, with additional integrated reactors for oxidation and reduction. Air evaporation reclaims water from the primary processor brine, allowing almost complete water recovery. Product water from the air evaporator passes back to the primary processor. Product water from the vapor phase catalytic ammonia removal assembly requires no further polishing, though a process control water quality monitor provides water quality assurance. Recovery efficiency with this system is high with reduced expendables compared to the ISS ECLSS suite.

#### 2.4.1.2.6 Human Accommodations

The ALS approach assumes an aqueous laundry. This will significantly increase the daily grey water load, but reduce the required mass of clothing compared to the ISS ECLSS approach. While the actual clothing usage rate remains unchanged, the laundry system cleans soiled clothing for reuse, prolonging clothing life and reducing associated waste loads.



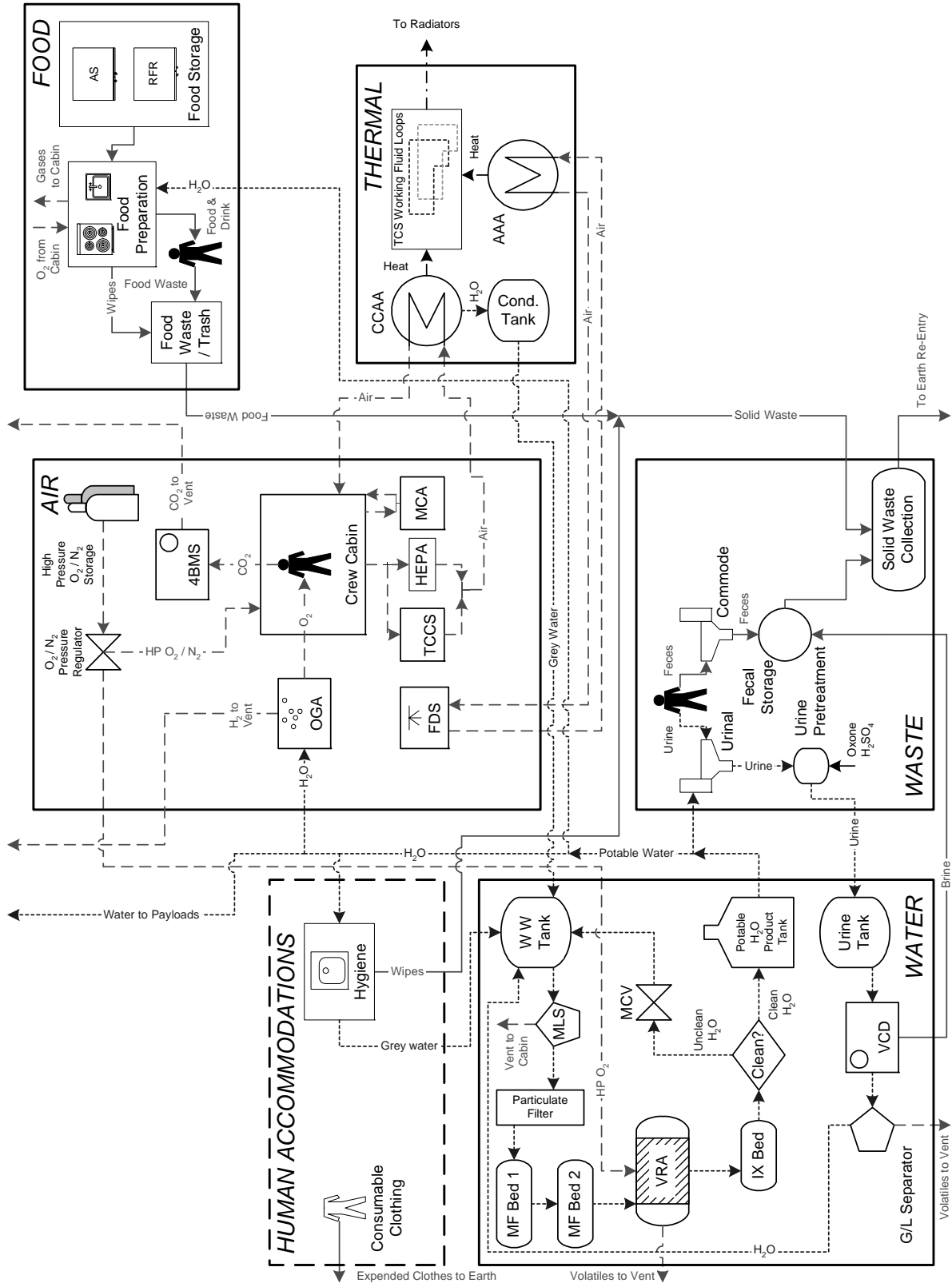

Figure 2.4.1 International Space Station Upgrade Mission using ISS ECLSS Baseline Technologies. See Section 7 for acronyms.

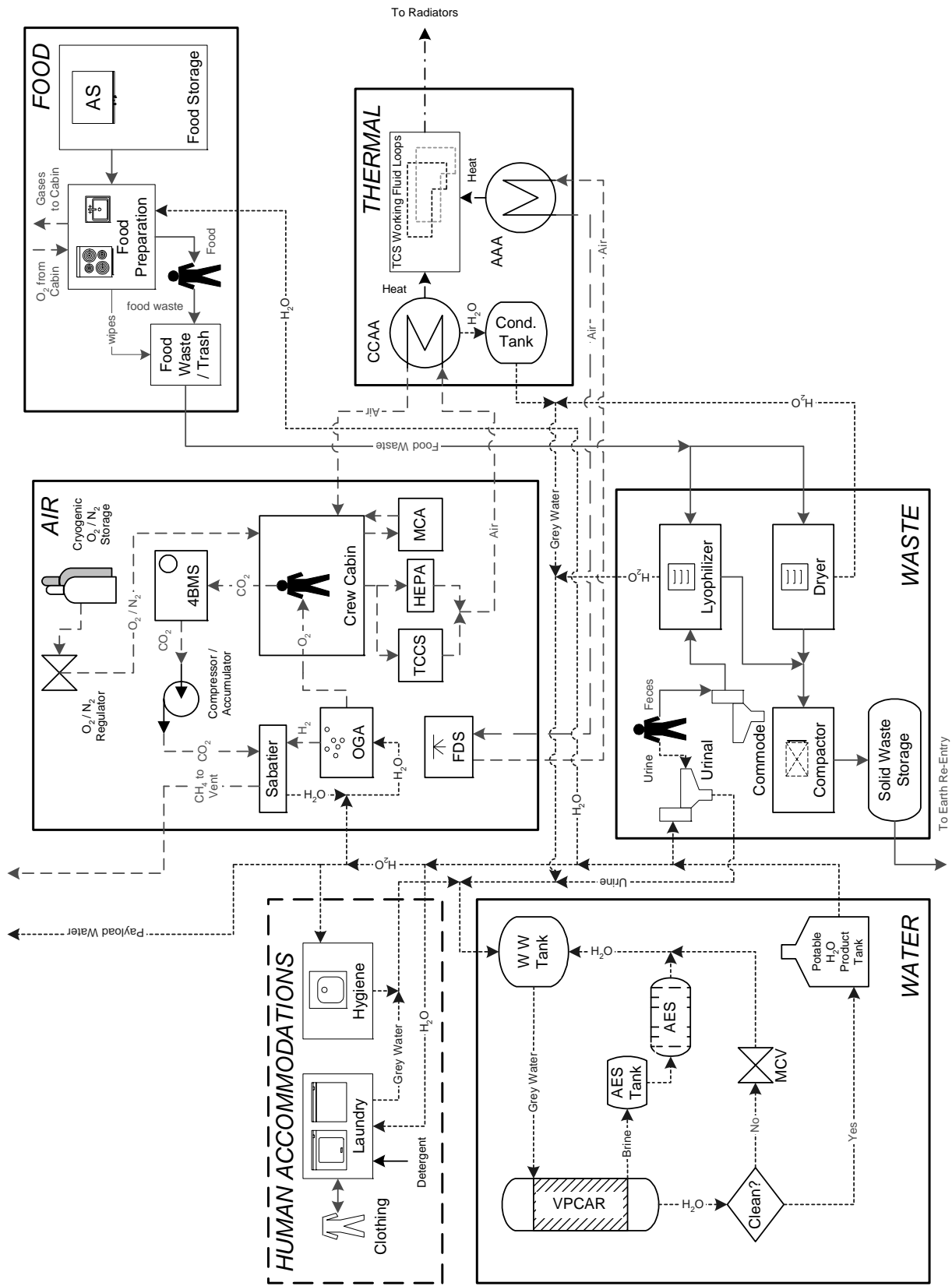

Figure 2.4.2 International Space Station Upgrade Mission using ALS Technologies. See Section 7 for acronyms.

## 2.4.2 INDEPENDENT EXPLORATION MISSION: MARS TRANSIT VEHICLE

The Mars Transit Vehicle uses inflatable modules with radiation shielding for interplanetary travel. However, with the infrastructure values assumed, per Table 2.4.3, the cabin radiation shielding does not protect the life support equipment.<sup>10</sup> Thus, the volume infrastructure value reflects a pressurized, inflatable structure without radiation shielding. Power is provided by solar photovoltaic generation with minimal energy storage. The external thermal control system uses a single-phase, pumped-loop to transport thermal energy and rejects the loads using body-fitted, flow-through radiators. Table 2.4.2 details specific inputs for the Mars Transit Vehicle segment of the Independent Exploration Mission.

### 2.4.2.1 INTERNATIONAL SPACE STATION ENVIRONMENTAL CONTROL AND LIFE SUPPORT SYSTEM TECHNOLOGY BASELINE

The ISS ECLSS technology suite, for the purposes of this document, is defined based on the USOS ECLSS scaled for a crew of six. See Stafford, *et al.* (2001), for details. This suite uses physicochemical technologies to regenerate air and water, while food is supplied mainly as prepackaged individual entrees, including frozen food selections. Because of the long mission duration, biomass production chamber provides salad to supplement the prepackaged food system.<sup>11</sup> Waste is generally stored without reclaiming any products from that waste. Cooling employs coldplates and condensing heat exchangers to collect heat loads, a single-phase fluid to transport heat, and radiators to reject heat. For this assessment, the applied cooling-mass penalty represents radiators constructed solely from aluminum and other metallic materials. Clothing is supplied from Earth clean and discarded to the waste subsystem once it is deemed too dirty to wear. See Figure 2.4.3.

#### 2.4.2.1.1 Air

The life support system for the Mars Transit Vehicle using ISS ECLSS technologies employs regenerable carbon dioxide removal equipment based on molecular sieve technology. The absorbed carbon dioxide is dumped overboard and not recovered. The trace gas contaminant system uses activated carbon, for non-combustible trace gas removal, and bacteria filter assemblies, for particulate removal. These filters are not regenerated. Further, the trace contaminant control system also removes trace combustible gases in the crew cabin. Oxygen is supplied both as pressurized gas from high-pressure stores, and as a product from electrolysis of water using solid polymer technology. The associated product hydrogen is dumped overboard. Water for electrolysis is provided by the water subsystem. Because the Mars Transit Vehicle will be “water rich” from moisture stored in food and the relatively high rate of water reclamation from grey water, most oxygen will be generated by electrolysis. Nitrogen is supplied from high-pressure gas stocks. A major constituent analyzer and a fire detection and suppression system provide monitoring for air contaminants and combustion products.

#### 2.4.2.1.2 Biomass

The ISS suite contains a small biomass production chamber, providing salad crops as a supplement to an otherwise prepackaged food system. Though the dietary nutrients gained from salad crops are relatively minor, salads, snacks, and steamed entrees provide a psychological advantage unavailable in a completely prepackaged food system and support anticipated requirements for long-duration space missions.<sup>12</sup> Supporting equipment for the biomass production chamber includes a nutrient

---

<sup>10</sup> In fact, efficient design may use the mass of the life support hardware as partial radiation protection from the crew cabin, but any “radiation credit” may be difficult to forecast and, therefore, none is assumed here.

<sup>11</sup> While International Space Station Upgrade Mission is longer than the combined mission durations for all vehicles within the Mars Independent Exploration architecture, individual ISS crewmembers usually spend significantly less than a year per deployment to ISS. Thus, while fresh salad is assumed here as essential for crew physical and psychological health on extended missions, this concern likely does not apply to ISS crewmembers.

<sup>12</sup> Biomass production is not part of the current ISS ECLSS technology suite, so a salad machine may seem “odd” here. However, the significant rationale for a small biomass production facility like a salad machine is related to

solution supply, condensate storage, and a supplemental common cabin air assembly to handle the greater humidity loading and air circulation requirements.

#### 2.4.2.1.3 Food

Food is provided as individual entrees from Earth. The Mars Transit Vehicle relies on a variety of a mix of fresh, dehydrated, and full-water preserved, shelf-stable, or frozen foods. The diet is supplemented with fresh salad, snacks, and steamed entrees from a biomass production chamber. Nominally, 11.82 MJ/CM-d of energy as food is supplied, corresponding to 1.362 kg/CM-d. Neglecting the dry component, the food mass as-shipped is 0.701 kg/CM-d. In either case, 0.238 kg/CM-d of disposable packaging is required. The corresponding specialized food storage structure adds an additional 0.362 kg/CM-d. Supporting technology includes a freezer and some food preparation equipment.

#### 2.4.2.1.4 Thermal

Thermal management is divided into two systems. The internal thermal control system includes the avionic air assemblies, which provide air-cooling for equipment, the common cabin air assemblies, which cool, dehumidify, and circulate cabin air, condensate storage, and the water flow loops for heat transport. Coldplates and heat exchangers are assumed part of other equipment while the external thermal control system is included in the assessed cooling-mass penalty.

#### 2.4.2.1.5 Waste

Solid waste is stored aboard the Mars Transit Vehicle. This includes trash, fecal material, brine from the urine and water processing, and used filters and cartridges. The toilet is also included in the waste subsystem.

#### 2.4.2.1.6 Water

Urine is processed by vapor compression distillation. Eighty-eight percent water recovery is claimed. The brine is dumped or placed in waste storage. All grey water, including hygiene water, effluent from the vapor compression distillation, and condensate from dehumidification, is processed through a water processor. The water processor employs two multifiltration units, a volatile removal assembly, phase separators, and an ion exchange bed. A process control water quality monitor provides water quality assurance. Efficiency of recovery is high, but many expendables, mostly filter cartridges, are needed. Additional water may enter the life support system directly, such as from moisture within prepackaged food, or indirectly, as a human metabolic product from the metabolism of food. A third source of water is stores, but in the nominal case the Mars Transit Vehicle will probably be “water rich.”

#### 2.4.2.1.7 Human Accommodations

Clothing is launched with the crew at the beginning of this mission and returns to Earth with the crew at the end of this mission. A usage rate of 0.486 kg/CM-d, in a volume of 0.00285 m<sup>3</sup>/CM-d, is assumed.

### 2.4.2.2 *ADVANCED LIFE SUPPORT TECHNOLOGY*

Though similar to the ISS ECLSS approach above, the advanced technology suite for the Mars Transit Vehicle employs a vapor phase catalytic ammonia removal water recovery system, a Sabatier to reduce carbon dioxide, stores pressurization gases as cryogens, and substitutes a completely ambient food subsystem. The salad machine is retained. Additionally, an aqueous laundry recycles crew clothing. The applied cooling-mass penalty reflects lightweight radiators constructed from composite materials. See Figure 2.4.4.

#### 2.4.2.2.1 Air

The advanced life support suite, compared to the ISS ECLSS suite in Section 2.4.2.1.1, adds a Sabatier carbon dioxide reduction assembly and stores gases for pressurization as cryogens instead of under

---

requirements for dietary diversity. Thus, a salad machine is included in both life support system configurations here to meet a requirement that is beyond those associated with ISS.

high pressure. Adequate water is available to avoid a supply penalty for any necessary oxygen and hydrogen. Sabatier reduces carbon dioxide according to the availability of hydrogen from the oxygen generation assembly. Carbon dioxide that is not reduced is vented to space. High efficiency particulate air filters provide particulate removal. Other technologies within the ALS air suite are identical to those within the ISS ECLSS technology suite for air as listed in Section 2.4.2.1.1.

#### 2.4.2.2.2 Biomass

The biomass subsystem here is identical to the ISS ECLSS suite in Section 2.4.2.1.2.

#### 2.4.2.2.3 Food

Food is provided as individual entrees with some bulk packaged items. This diet relies on a variety of ambient temperature foods. The diet is supplemented with fresh salad, snacks, and steamed entrees from a biomass production chamber. Nominally, 11.82 MJ/CM-d of energy as food is supplied, corresponding to 1.138 kg/CM-d. Neglecting the dry component, the food mass as-shipped is 0.481 kg/CM-d. Additionally, 0.211 kg/CM-d of disposable packaging is required. The corresponding specialized food storage structure adds an additional 0.268 kg/CM-d. Supporting technology includes a microwave oven.

#### 2.4.2.2.4 Thermal

The advanced life support suite for the thermal subsystem uses the same technologies as the ISS ECLSS suite for the thermal subsystem described in Section 2.4.2.1.4.

#### 2.4.2.2.5 Waste

The advanced life support suite for waste management uses the same technologies as the ISS ECLSS suite for waste management described in Section 2.4.2.1.5.

#### 2.4.2.2.6 Water

The ALS water system is built around a vapor phase catalytic ammonia removal assembly to provide primary water processing of both urine and grey water. Air evaporation reclaims water from the primary processor brine, allowing almost complete water recovery. Product water from the air evaporator passes to the primary processor. Product water from the vapor phase catalytic ammonia removal assembly requires no further polishing, though a process control water quality monitor provides water quality assurance. Overall recovery efficiency with this system is also high, with reduced expendables, compared to the ISS ECLSS suite.

#### 2.4.2.2.7 Human Accommodations

The advanced life support approach assumes an aqueous laundry. This will significantly increase the daily grey water load, but reduce the required mass of clothing compared to the ISS ECLSS approach. While the actual clothing usage rate remains unchanged, the laundry system cleans soiled clothing for reuse, prolonging clothing life and reducing associated waste loads.

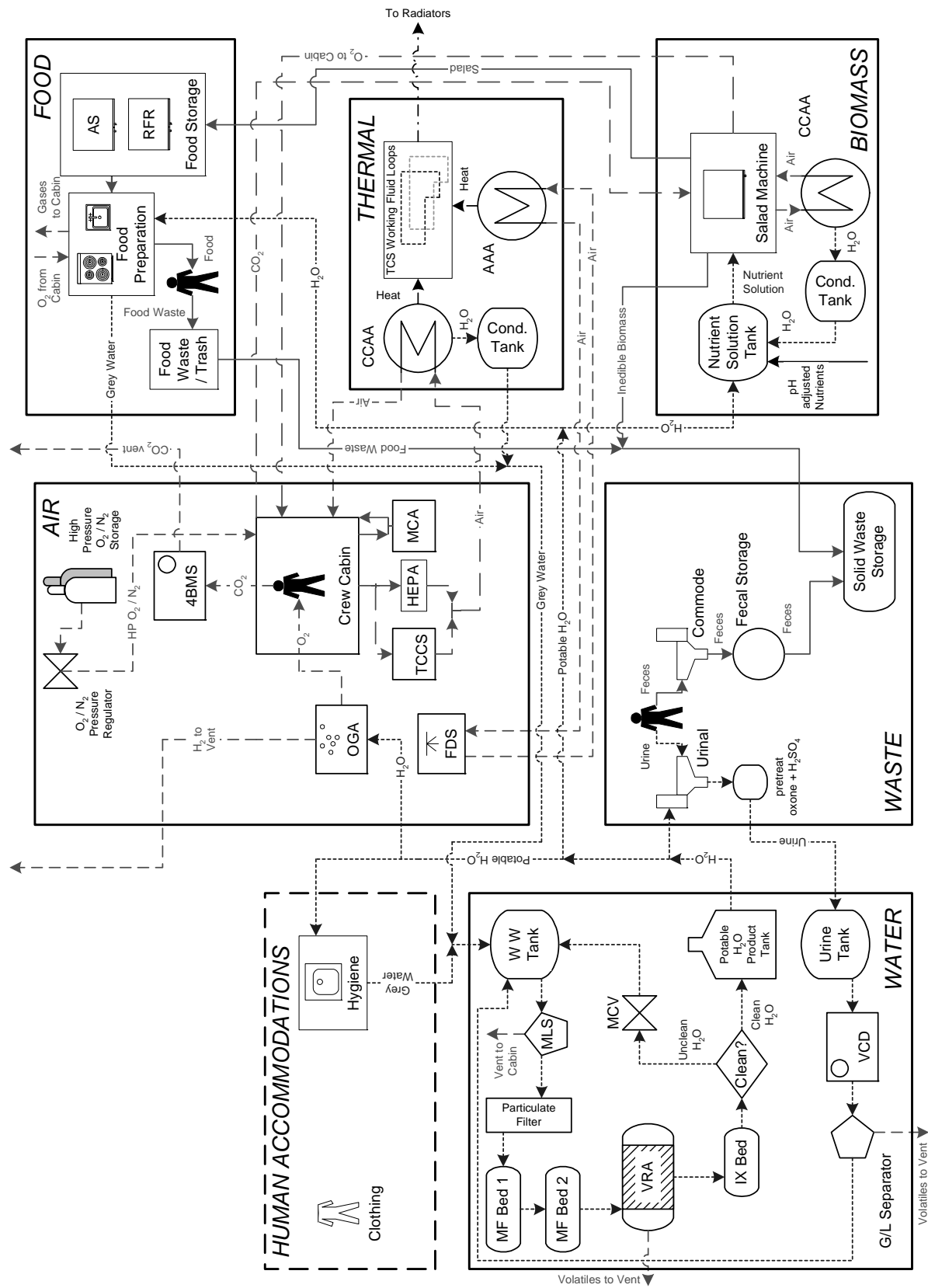

Figure 2.4.3 Mars Transit Vehicle using ISS ECLSS Baseline Technologies. See Section 7 for acronyms.

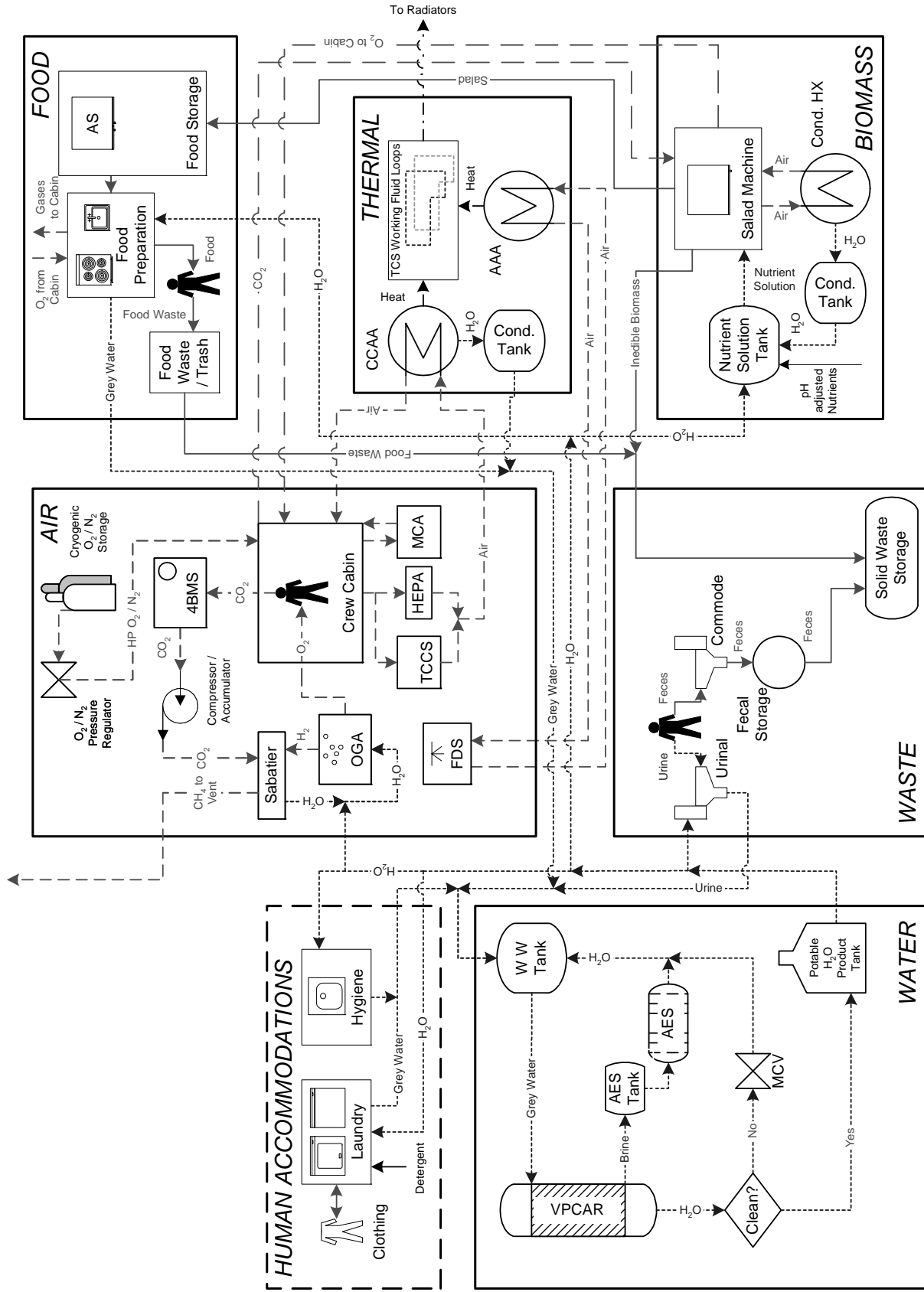

Figure 2.4.4 Mars Transit Vehicle using ALS Technologies. See Section 7 for acronyms.

### 2.4.3 INDEPENDENT EXPLORATION MISSION: MARS DESCENT / ASCENT LANDER

The infrastructure penalties for the Mars Descent / Ascent Lander are associated with surface operations. This vehicle uses rigid aluminum modules per International Space Station architecture. Solar photovoltaic panels with regenerable fuel cell storage, assuming an equatorial surface site, provide power. The external thermal control system uses a single-phase, pumped loop to transport thermal energy and rejects the thermal loads using body-fitted, flow-through radiators. Again, an equatorial site on the Martian surface is assumed. While this vehicle will spend sufficient time operating in Martian orbit and, as a result, infrastructure for that phase must be considered for any viable vehicle. Past experience dictates that the most severe sizing constraints are placed upon solar photovoltaic power generation and radiant cooling systems by the Martian surface environment when considering an equatorial landing site. Table 2.4.3 lists assumed infrastructure values while Table 2.4.2 details specific inputs for the Mars Descent / Ascent Lander segment of the Independent Exploration Mission.

#### 2.4.3.1 INTERNATIONAL SPACE STATION ENVIRONMENTAL CONTROL AND LIFE SUPPORT SYSTEM TECHNOLOGY BASELINE

The ISS ECLSS technology suite, for the purposes of this document, is defined based on current technology from ISS or Shuttle scaled for a crew of six. See Stafford, *et al.* (2001), for details. This suite uses physicochemical technologies to regenerate air and water, while food is supplied as individual prepackaged entrees, including frozen food selections. Waste is stored without reclaiming any commodities. Thermal management employs coldplates and condensing heat exchangers to collect heat loads, a single-phase fluid to transport heat, and radiators to reject heat. Clothing is supplied from Earth clean and discarded to the waste subsystem once it is deemed too dirty to wear. See Figure 2.4.5.

##### 2.4.3.1.1 Air

The ISS ECLSS air suite for the Mars Descent / Ascent Lander uses regenerable carbon dioxide removal equipment based on molecular sieve technology. The absorbed carbon dioxide is dumped overboard without recovering any commodities. The trace contaminant control system for atmospheric gases uses activated carbon, for non-combustible trace gas removal, and bacteria filter assemblies, for particulate removal, neither of which are regenerated. Further, the trace contaminant control system also removes trace combustible gases in the crew cabin. Oxygen is supplied both as pressurized gas from high-pressure stores, and as a product from electrolysis of water using solid polymer technology. The associated product hydrogen is dumped overboard. Electrolysis water is provided by the water subsystem. Nitrogen is supplied from high-pressure gas stocks. A major constituent analyzer and a fire detection and suppression system provide monitoring for air contaminants and combustion products.

##### 2.4.3.1.2 Food

Food is provided as individual entrees from Earth. A mix of fresh, dehydrated, and full-water preserved, shelf-stable, or frozen foods are used. Nominally, 11.82 MJ/CM-d of energy as food is supplied, corresponding to 1.378 kg/CM-d. Neglecting the dry component, the food mass as-shipped is 0.710 kg/CM-d. In addition, 0.241 kg/CM-d of disposable packaging is required. The corresponding specialized food storage structure adds an additional 0.368 kg/CM-d. Supporting technology includes a freezer and some food preparation equipment.

##### 2.4.3.1.3 Thermal

Thermal management for the Mars Descent / Ascent Lander is divided between two systems here. The internal thermal control system includes the avionic air assemblies, which provide air-cooling for equipment, the common cabin air assemblies, which dehumidify cabin air, condensate storage, and the flow loops. Coldplates and heat exchangers are assumed part of other equipment while the external thermal control system is included in the assessed cooling-mass penalty.



#### 2.4.3.1.4 Waste

The waste system provides only for rudimentary collection and storage of waste products. The waste system includes a toilet, pretreatment to stabilize urine, and separate storage for human metabolic wastes and trash.

#### 2.4.3.1.5 Water

Urine is processed by vapor compression distillation. Eighty-eight percent water recovery is claimed. The brine is sent to the waste subsystem. All grey water, including hygiene water, effluent from the vapor compression distillation, and condensate from dehumidification, is processed through a water processor. The water processor employs two multifiltration units, a volatile removal assembly, phase separators, and an ion exchange bed. A process control water quality monitor provides water quality assurance. Efficiency of recovery is high, but many expendables, mostly filter cartridges, are needed. Additional water comes from stores.

#### 2.4.3.1.6 Extravehicular Activity Support

While extravehicular activities from the Mars Descent / Ascent Lander are essential to mission success, such activities are expected to be limited in number. Thus, the entire cabin will function as an airlock and no effort is made to recover cabin gases before depressurization, preferring instead to simply repressurize the cabin from gas stocks when the crew reoccupies the Mars Descent / Ascent Lander en route to rendezvous with the Mars Transit Vehicle. The life support system is expected to provide stores of water and oxygen to the extravehicular mobility units for cooling and crew consumption, and water to charge the internal liquid cooling loops.

#### 2.4.3.1.7 Human Accommodations

Clothing is launched with the vehicle before the Mars Descent / Ascent Lander leaves Earth. This clothing will remain with the vehicle when the crew departs either for surface operations or upon returning to the Mars Transit Vehicle. This clothing is not laundered. A usage rate of 0.486 kg/CM-d, in a volume of 0.00285 m<sup>3</sup>/CM-d, is assumed.

### 2.4.3.2 ADVANCED LIFE SUPPORT TECHNOLOGY

The advanced life support suite for the Mars Descent / Ascent Lander uses the same technologies as the ISS ECLSS suite for the waste subsystem, water subsystem, extravehicular activity support, and human accommodations. The advanced life support suite uses many different technologies within the air subsystem and the food subsystem. The applied cooling-mass penalty reflects advanced technologies in the form of lightweight radiators constructed from composite materials. See Figure 2.4.6.

#### 2.4.3.2.1 Air

The air subsystem for the advanced life support suite within the Mars Descent / Ascent Lander uses a solid amine vacuum desorbed processor to remove cabin carbon dioxide loads. Oxygen is not reclaimed from the carbon dioxide. An ambient temperature catalytic oxidizer removes carbon monoxide.<sup>13</sup> Oxygen is supplied only from stores, and all pressurization gases are supplied from cryogenic sources. Other air subsystem hardware is identical to the technologies described for the ISS ECLSS air subsystem in Section 2.4.3.1.1.

#### 2.4.3.2.2 Food

Food is provided as individual entrees. This diet relies on a variety of ambient temperature, low-moisture-content foods. Nominally, 11.82 MJ/CM-d of energy as food is supplied, corresponding to 0.922 kg/CM-d. Neglecting the dry component, the food mass as-shipped is 0.257 kg/CM-d. 0.268 kg/CM-d of disposable packaging is required. The corresponding specialized food storage structure adds an additional 0.330 kg/CM-d. Supporting technology includes a microwave oven.

---

<sup>13</sup> Because the ambient temperature catalytic oxidizer does not remove a wider variety of contaminants, it is not suitable for longer duration missions where other trace contaminants besides carbon monoxide may accumulate to problematic concentrations.

#### 2.4.3.2.3 Thermal

The thermal subsystem for the advanced life support suite within the Mars Descent / Ascent Lander is identical to the technologies listed for the ISS ECLSS thermal subsystem in Section 2.4.3.1.3.

#### 2.4.3.2.4 Waste

The waste subsystem for the advanced life support suite within the Mars Descent / Ascent Lander is identical to the technologies described for the ISS ECLSS waste subsystem in Section 2.4.3.1.4.

#### 2.4.3.2.5 Water

The water subsystem for the advanced life support suite within the Mars Descent / Ascent Lander is identical to the technologies described for the ISS ECLSS waste subsystem in Section 2.4.3.1.5.

#### 2.4.3.2.6 Extravehicular Activity Support

The extravehicular activity support for the ALS life support system within the Mars Descent / Ascent Lander is identical to the technologies described for the ISS ECLSS extravehicular activity support suite in Section 2.4.3.1.6.

#### 2.4.3.2.7 Human Accommodations

The human accommodations for the ALS life support system within the Mars Descent / Ascent Lander is identical to the technologies described for the ISS ECLSS human accommodations suite in Section 2.4.3.1.7.

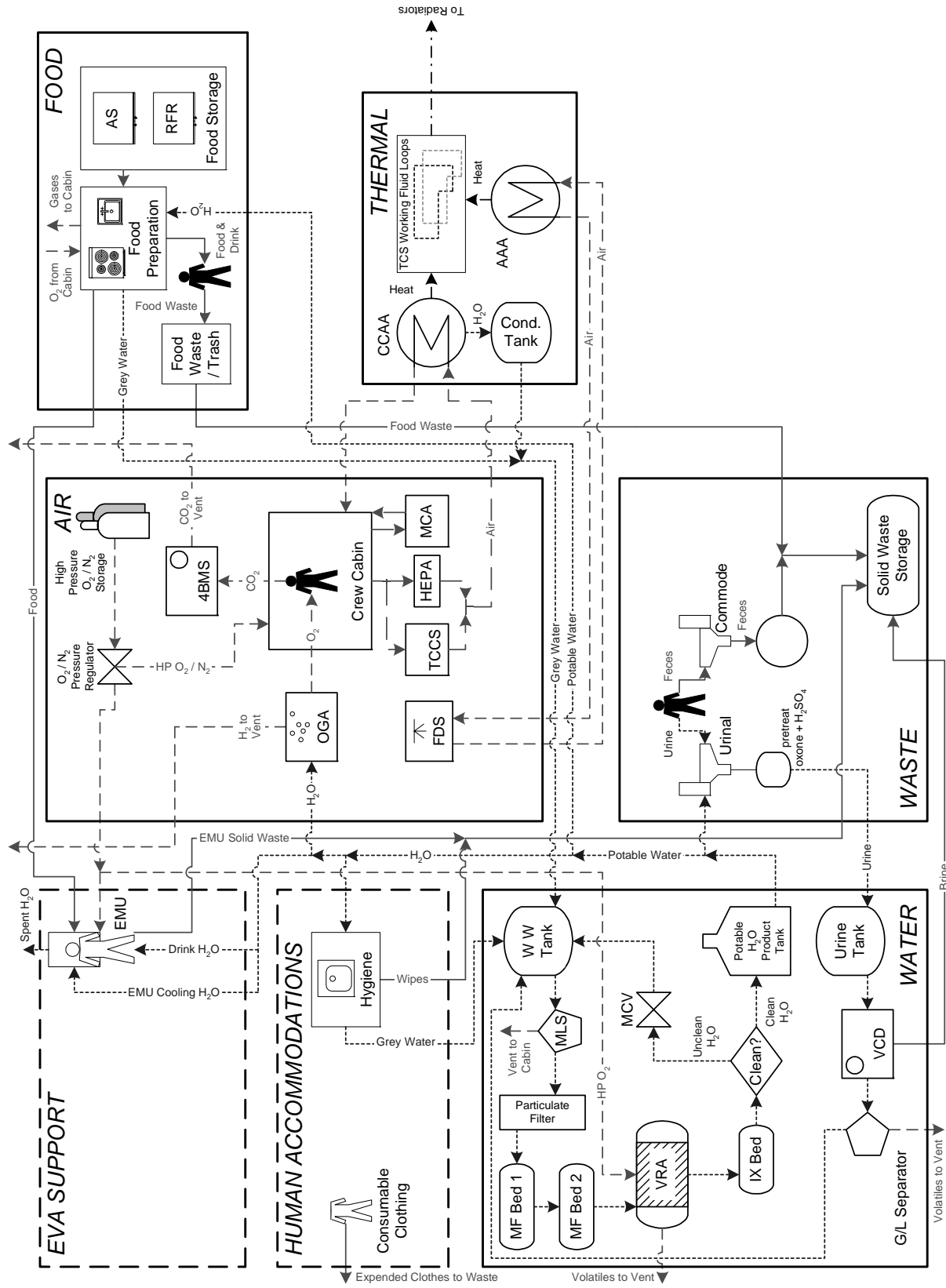

Figure 2.4.5 Mars Descent / Ascent Lander using ISS ECLSS Baseline Technologies. See Section 7 for acronyms.

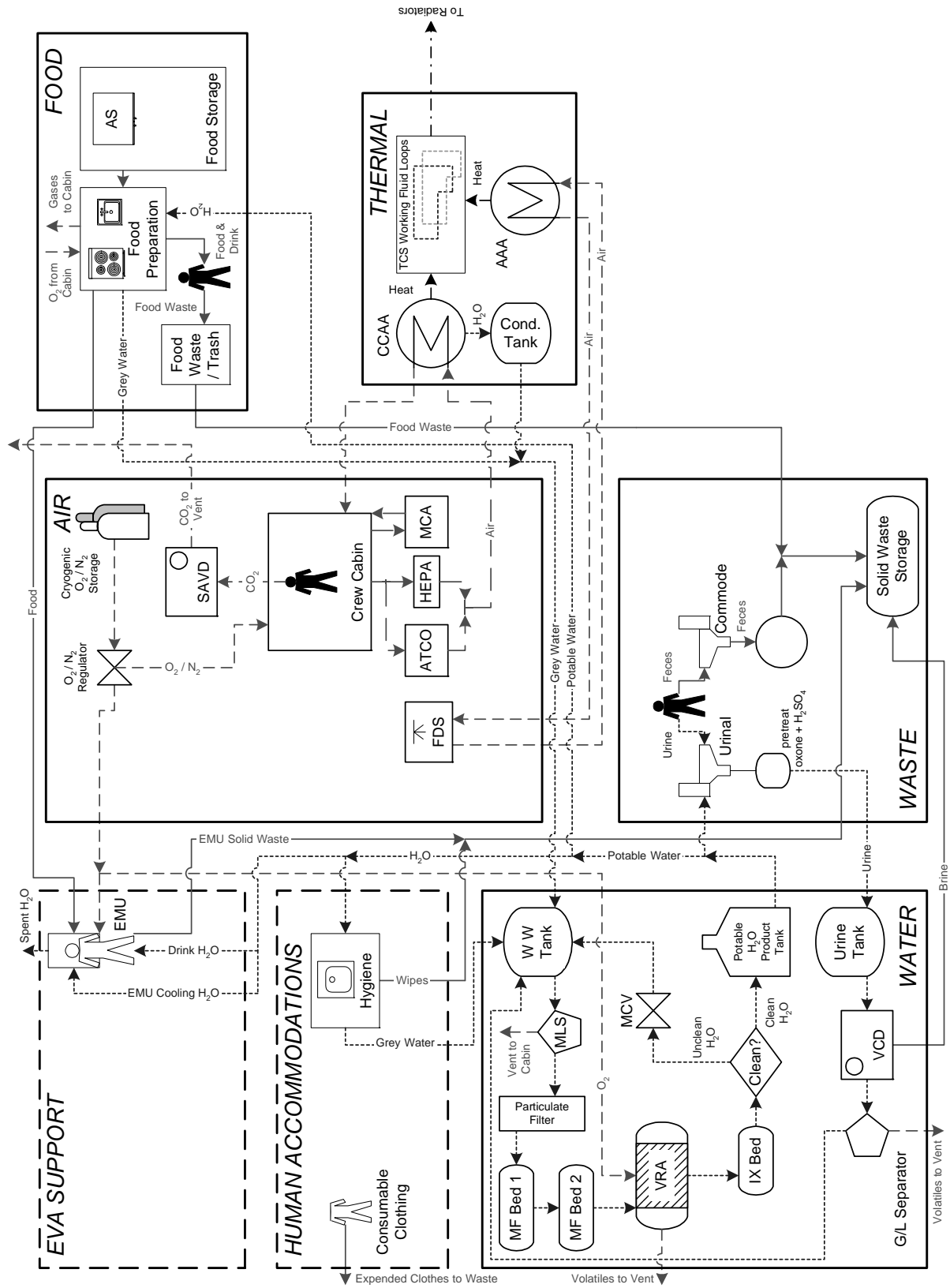

Figure 2.4.6 Mars Descent / Ascent Lander using ALS Technologies. See Section 7 for acronyms.

#### 2.4.4 INDEPENDENT EXPLORATION MISSION: SURFACE HABITAT LANDER

The Surface Habitat Lander assumes an inflatable module without radiation protection with the implied assumption that life support hardware is hardened versus environmental radiation loads. The crew may be housed within a hardened domain, but this is not included in the assessed infrastructure values for life support system hardware. A small nuclear reactor provides continuous power. The assumed value corresponds to a 100 kW<sub>e</sub> nuclear reactor on an independent lander, but an actual system for this mission will likely be much smaller, both in capacity and overall mass, so the infrastructure value assumed is an approximation of the actual system. The external thermal control system uses a single-phase, pumped loop to transport thermal energy and rejects the thermal loads using body-fitted, flow-through radiators. An equatorial site on the Martian surface is assumed. Table 2.4.3 lists assumed infrastructure values while Table 2.4.2 details specific inputs for the Surface Habitat Lander segment of the Independent Exploration Mission.

##### 2.4.4.1 INTERNATIONAL SPACE STATION ENVIRONMENTAL CONTROL AND LIFE SUPPORT SYSTEM TECHNOLOGY BASELINE

The ISS ECLSS technology suite, for the purposes of this document, is defined based on the USOS ECLSS scaled for a crew of six. See Stafford, *et al.* (2001), for details. This suite uses physicochemical technologies to regenerate air and water, while food is supplied mainly as prepackaged individual entrees, including frozen food selections. Because of the long mission duration, biomass production chamber provides salad to supplement the prepackaged food system.<sup>14</sup> Waste is generally stored without reclaiming any products from that waste. Cooling employs coldplates and condensing heat exchangers to collect heat loads, a single-phase fluid to transport heat, and radiators to reject heat. For this assessment, the applied cooling-mass penalty represents radiators constructed solely from aluminum and other metallic materials. Clean clothing is launched with the vehicle and left on the surface with the vehicle upon the departure of the crew from Mars. See Figure 2.4.7.

###### 2.4.4.1.1 Air

The ISS ECLSS air suite on the Surface Habitat Lander uses regenerable carbon dioxide removal equipment based on molecular sieve technology. The absorbed carbon dioxide is dumped overboard without recovering any commodities. The trace contaminant control system for atmospheric gases uses activated carbon, for non-combustible trace gas removal, and bacteria filter assemblies, for particulate removal, neither of which are regenerated. Further, the trace contaminant control system also removes trace combustible gases in the crew cabin. Oxygen is supplied both as pressurized gas from high-pressure stores, and as a product from electrolysis of water using solid polymer technology. The associated product hydrogen is dumped overboard. Electrolysis water is provided by the water subsystem. Nitrogen is supplied from high-pressure gas stocks. A major constituent analyzer and a fire detection and suppression system provide monitoring for air contaminants and combustion products.

###### 2.4.4.1.2 Biomass

The ISS suite contains a small biomass production chamber, providing salad crops to supplement the prepackaged food system. Though the dietary nutrients gained from salad crops are relatively minor, salads, snacks, and steamed entrees provide a psychological advantage unavailable in a completely prepackaged food system and support anticipated requirements for long-duration space missions.<sup>15</sup>

---

<sup>14</sup> While International Space Station Upgrade Mission is longer than the combined mission durations for all vehicles within the Mars Independent Exploration architecture, individual ISS crewmembers usually spend significantly less than a year per deployment to ISS. Thus, while fresh salad is assumed here as essential for crew physical and psychological health on extended missions, this concern likely does not apply to ISS crewmembers.

<sup>15</sup> Biomass production is not part of the current ISS ECLSS technology suite, so a salad machine may seem “odd” here. However, the significant rationale for a small biomass production facility like a salad machine is related to requirements for dietary diversity. Thus, a salad machine is included in both life support system configurations here to meet a requirement that is beyond those associated with ISS.

Supporting equipment for the biomass production chamber includes a nutrient solution supply, condensate storage, and a supplemental common cabin air assembly to handle the greater humidity loading and air circulation requirements.

#### 2.4.4.1.3 Food

Food is provided as individual entrees from Earth. This system relies on a variety of a mix of fresh, dehydrated, and full-water preserved, shelf-stable, or frozen foods. The diet is supplemented with fresh salad, snacks, and steamed entrees from a biomass production chamber. Nominally, 11.82 MJ/CM-d of energy as food is supplied, corresponding to 1.362 kg/CM-d. Neglecting the dry component, the food mass as-shipped is 0.701 kg/CM-d. Additionally, 0.238 kg/CM-d of disposable packaging is required. The corresponding specialized food storage structure adds an additional 0.361 kg/CM-d. Supporting technology includes a freezer and some food preparation equipment.

#### 2.4.4.1.4 Thermal

Thermal management is divided into two systems. The internal thermal control system includes the avionic air assemblies, which provide air-cooling for equipment, the common cabin air assemblies, which cool and dehumidify cabin air, condensate storage, and the water flow loops for heat transport. Coldplates and heat exchangers are assumed part of other equipment while the external thermal control system is included in the assessed cooling-mass penalty.

#### 2.4.4.1.5 Waste

Solid waste is simply stored, without treatment, aboard the Surface Habitat Lander. This includes trash, fecal material, brine from the urine and water processing, and used filters and cartridges. The toilet is also included in this calculation under the waste subsystem.

#### 2.4.4.1.6 Water

Urine is processed by vapor compression distillation. Eighty-eight percent water recovery is claimed. The brine is stored and remains with the vehicle after the crew departs. All grey water, including hygiene water, effluent from the vapor compression distillation, and condensate from dehumidification, is processed through a water processor. The water processor employs two multifiltration units, a volatile removal assembly, phase separators, and an ion exchange bed. A process control water quality monitor provides water quality assurance. Efficiency of recovery is high, but many expendables, mostly filter cartridges, are needed. Water may enter the life support system directly, such as from moisture within prepackaged food, or indirectly, as a human metabolic product from the consumption of the prepackaged food. Water may also come from water stores. Due to the high frequency of extravehicular activities, the Surface Habitat Lander will probably be “water poor” in the nominal case without additional stores.

#### 2.4.4.1.7 Extravehicular Activity Support

The extravehicular mobility unit consumables include oxygen, for metabolic consumption and suit pressurization, and water, which is rejected to provide thermal management and consumed by the crew as drinks. Though not consumed, water also provides the working fluid for the internal cooling garment. This extravehicular mobility unit uses lithium hydroxide for carbon dioxide removal. An airlock pump, which is a compressor, reduces the airlock internal pressure to about ten percent of the cabin pressure, reducing gas losses during airlock operations. Hardware to generate oxygen specifically for extravehicular activities, oxygen recharge compressor assembly,<sup>16</sup> is also included. Atmospheric gas and water losses are actually included as part of the air and water subsystems in this calculation, and not as part of the values presented for extravehicular activity support.

---

<sup>16</sup> The oxygen recharge compressor assembly (ORCA) is an ISS technology for compressing oxygen to serve extravehicular mobility units.

#### 2.4.4.1.8 Human Accommodations

Clothing is launched from Earth with the Surface Habitat Lander and stays with the vehicle at the end of the surface phase. When clothing is deemed too dirty to wear, it is stowed with the other dirty clothing and replaced with a clean garment from stores. A usage rate of 0.486 kg/CM-d, in a volume of 0.00285 m<sup>3</sup>/CM-d, is assumed.

#### 2.4.4.2 *ADVANCED LIFE SUPPORT TECHNOLOGY*

The advanced life support suite is significantly different from the ISS ECLSS approach above. Cryogenic gas storage, vapor phase catalytic ammonia removal, and an ambient food system are less massive than similar ISS ECLSS technologies, while Sabatier, warm-air drying with lyophilization, and an aqueous laundry are all designed to help close various life support commodity loops within the vehicle. As above, the salad machine is retained in the advanced suite. The applied cooling-mass penalty reflects lightweight radiators constructed from composite materials. See Figure 2.4.8.

##### 2.4.4.2.1 Air

The advanced air suite within the Surface Habitat Lander, compared to the ISS ECLSS suite detailed in Section 2.4.4.1.1, adds a Sabatier carbon dioxide reduction assembly with a gas stream compressor and stores pressurization gases as cryogens. Adequate water is available to avoid a supply penalty for any necessary oxygen and hydrogen. Specifically, Sabatier reduces carbon dioxide according to the availability of hydrogen from the oxygen generation assembly. Any carbon dioxide that is not reduced is vented to space. Other aspects of the ALS air suite are identical to the ISS ECLSS technology suite for air listed in Section 2.4.4.1.1.

##### 2.4.4.2.2 Biomass

The biomass subsystem here is identical to the ISS ECLSS suite in Section 2.4.4.1.2.

##### 2.4.4.2.3 Food

Food is provided as individual entrees with some bulk packaged items in the advanced food suite. This diet relies on a variety of ambient temperature foods. The diet is supplemented with fresh salad, snacks, and steamed entrees from a biomass production chamber. Nominally, 11.82 MJ/CM-d of energy as food is supplied, corresponding to 1.138 kg/CM-d. Neglecting the dry component, the food mass as-shipped is 0.482 kg/CM-d. In addition, 0.211 kg/CM-d of disposable packaging is required. The corresponding specialized food storage structure adds an additional 0.267 kg/CM-d. Supporting technology includes a microwave oven.

##### 2.4.4.2.4 Thermal

The advanced suite for the thermal subsystem uses the same technologies as the ISS ECLSS suite for the thermal subsystem described in Section 2.4.4.1.4.

##### 2.4.4.2.5 Waste

The advanced suite for waste uses a combination of warm-air drying and lyophilization to recover moisture from waste. Waste materials are compacted to reduce overall volume reduction before storage. Reclaimed water is returned to the water subsystem as grey water.

##### 2.4.4.2.6 Water

The advanced water system is built around a vapor phase catalytic ammonia removal assembly to provide primary water processing of both urine and grey water. Air evaporation reclaims water from the primary processor brine, allowing almost complete water recovery. Product water from the air evaporator passes to the primary processor. Product water from the vapor phase catalytic ammonia removal assembly requires no further polishing, though a process control water quality monitor provides water quality assurance.

#### 2.4.4.2.7 Extravehicular Activity Support

The advanced suite for extravehicular activity support is almost identical to the ISS ECLSS suite for extravehicular activity support. In the advanced life support system the hardware to compress oxygen specifically for extravehicular activities, the oxygen recharge compressor assembly, is omitted in favor of charging extravehicular systems directly from gas stores. It is assumed this has no mass impact, although the actual hardware will differ between the two cases. See Section 2.4.4.1.7.

#### 2.4.4.2.8 Human Accommodations

The advanced life support system assumes an aqueous laundry. This will significantly increase the daily grey water load, but reduce the required mass of clothing compared to the ISS ECLSS approach. While the actual clothing usage rate remains unchanged, the laundry system cleans soiled clothing for reuse, prolonging clothing life and reducing associated waste loads.



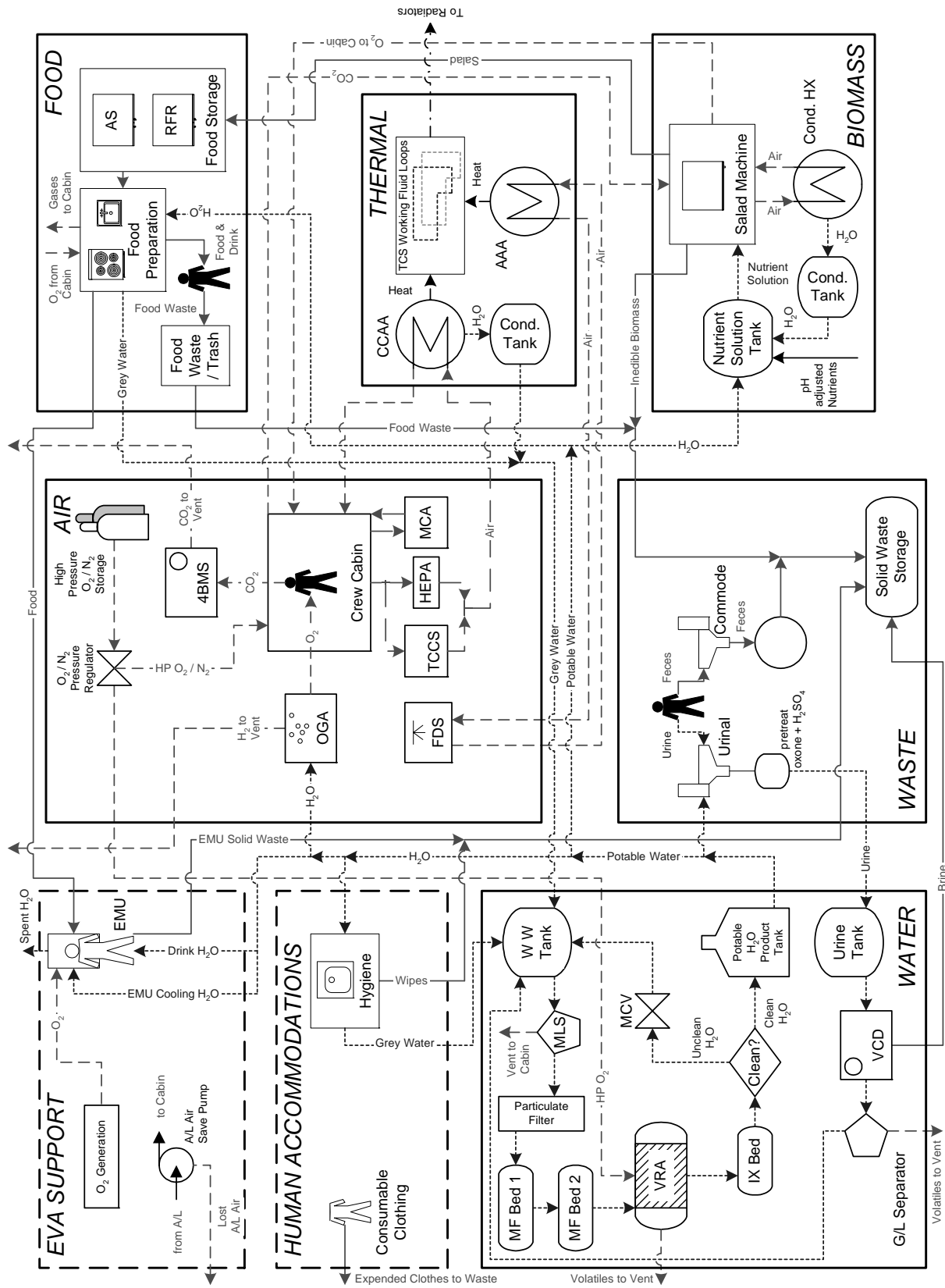

Figure 2.4.7 Surface Habitat Lander using ISS ECLSS Baseline Technologies. See Section 7 for acronyms.

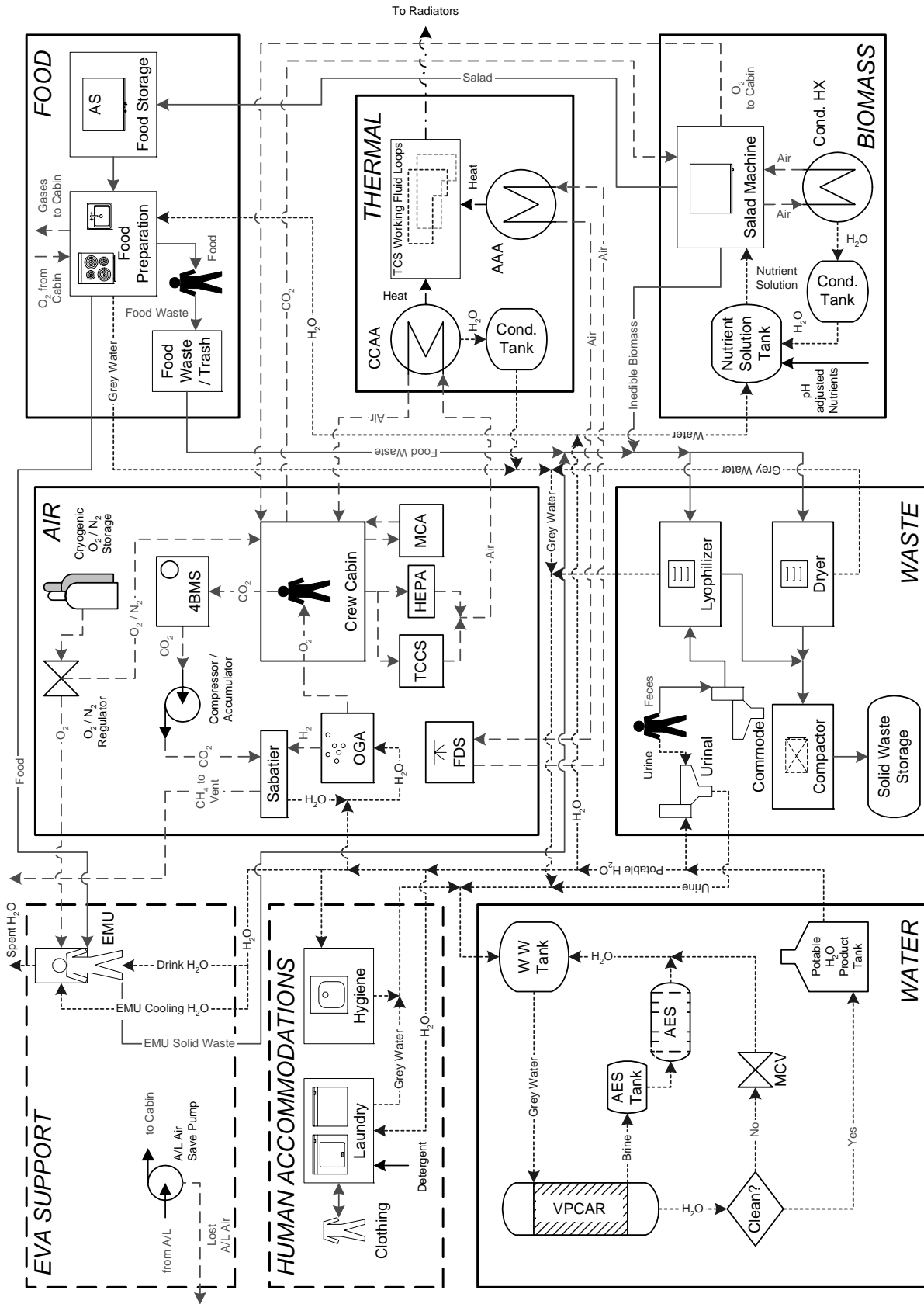

Figure 2.4.8 Surface Habitat Lander using ALS Technologies. See Section 7 for acronyms.

#### 2.4.5 MISSION PARAMETERS

The most significant overall mission parameters, based on Stafford, *et al.* (2001) and Hanford (2004), are provided in Table 2.4.1. Specifically, these values quantify the mission segment duration, crew cabin volume, number of pressurized modules, and additional thermal loads aside from those associated with the life support system. For example, such loads may represent avionics, experiments, or other functions not associated with life support. For these calculations, sixty percent of the thermal loads are removed from the crew cabin via the condensing heat exchanger, with coldplates removing the other forty percent. These values are unchanged from the Fiscal Year 2003 calculation (Hanford, 2003b).

**Table 2.4.1 Advanced Mission Parameters**

<b>Mission</b>	<b>Number of Pressurized Modules</b>	<b>Total Crew Cabin Volume [m<sup>3</sup>]</b>	<b>Additional Thermal Loads [kW<sub>th</sub>]</b>	<b>Mission or Segment Duration [d]</b>
<b>Orbiting Research Facility: International Space Station Update Mission</b>	6	1,330	121.0	3,650
<b>Independent Exploration Mission:</b>				~960 <sup>17</sup>
Mars Transit Vehicle	2	110	5.5	360
Mars Descent / Ascent Lander	1	25.5	1.0	30
Surface Habitat Lander	2	110	8.5	600

Specific input values for each parameter of the ALSSAT menus are listed in Table 2.4.2. ALSSAT entries that are not listed here are zero or are not used to compute the current Metric values.

---

<sup>17</sup> The duration of the total surface element is 600 days and the Surface Habitat Lander is sized for the full mission. In reality, the crew will probably spend a few days in the Mars Descent / Ascent Lander both just after landing and just before liftoff. The total duration for this vehicle is 30 days.

Table 2.4.2 Specific Input Values for Metric Mission Parameters

Parameter	Units	ISS		Mars Transit Vehicle Value	Mars Descent / Ascent Lander Value	Surface Habitat Lander Value
		Upgrade Value	Value			
Mission Definition						
Number of Crewmembers	CM	6	6	6	6	6
Mission Duration	[d]	3,650	360	30	600	600
Vehicle Definition Parameters						
Number of Modules	modules	6	2	1	2	2
Maximum Atmospheric Leakage per Module	[kg/d•mod]	0.00224	0.00224	0.00224	0.00224	0.00224
Total Pressurized Atmospheric Volume	[m <sup>3</sup> ]	1,330	110	25.5	110	110
Interior Atmosphere Definition						
Nominal Total Atmosphere Pressure	[kPa]	101.3	70.3	70.3	70.3	70.3
Nominal Atmosphere Oxygen Partial Pressure	[kPa]	21.3	21.3	21.3	21.3	21.3
Nominal Atmosphere Water Vapor Partial Pressure	[kPa]	1.2	1.2	1.2	1.2	1.2
Nominal Atmosphere Carbon Dioxide Partial Pressure	[kPa]	0.4	0.4	0.4	0.4	0.4
Nominal Crew Inputs						
Oral Hygiene Water	[kg/CM-d]	0.363	0.363	0.363	0.363	0.363
Hand / Face Wash Water	[kg/CM-d]	4.082	4.082	4.082	4.082	4.082
Urinal Flush Water	[kg/CM-d]	0.494	0.494	0.494	0.494	0.494
Laundry Water <sup>18</sup>	[kg/CM-d]	12.474	12.474	0	0	12.474
Water Supplied by Fuel Cells	[kg/CM-d]	0	0	0	0	0
Shower Water	[kg/CM-d]	0	2.722	0	0	2.722
Dishwashing Water	[kg/CM-d]	0	0	0	0	0
Drinking Water	[kg/CM-d]	2.000	2.000	2.000	2.000	2.000
EHS Sample Water <sup>19</sup>	[kg/CM-d]	0.212	0	0	0	0

<sup>18</sup> When a laundry is part of the life support system. Otherwise this value is zero.

<sup>19</sup> This represents water to payloads that is not recovered.

Table 2.4.2 Specific Input Values for Metric Mission Parameters (continued)

Parameter	Units	ISS		Mars		Mars Descent / Ascent		Surface Habitat Lander	
		Upgrade Value	Value	Transit Vehicle Value	Value	Lander Value	Lander Value	Value	Value
Thermal Control System, Vehicle Characteristics									
Characteristic Vehicle Length	[m]	51		5.6		3.61		5.6	
Characteristic Vehicle Radius	[m]	2.2		2.5		1.5		2.5	
Thermal Control System, Internal Thermal Control System (ITCS) Fluid Loop									
ITCS Inlet Temperature	[K]	275.00		275.00		275.00		275.00	
ITCS Outlet Temperature	[K]	308.15		308.15		308.15		308.15	
Avionics from Cold Plates <sup>20</sup>	[kW]	48.4		2.2		0.4		3.4	
Avionics from Heat Exchanger (HX) <sup>20</sup>	[kW]	72.6		3.3		0.6		5.1	
Percentage from Cold Plates	as a fraction	0.4		0.4		0.4		0.4	
Thermal Control System, ITCS Loop Characteristics									
ITCS Pump Efficiency (eta)	dimensionless	0.45		0.45		0.45		0.45	
ITCS Line Diameter (Outside Diameter)	[m]	0.0635		0.0127		0.009525		0.0127	
ITCS Effective Line Length Multiplier	dimensionless	10		10		10		10	
Thermal Control System, Physical Constants									
Maximum Insolation	[kW/m <sup>2</sup> ]	1.414		1.414		1.414		1.414	
Solar Incident Angle	[degrees]	90		90		30		30	
Albedo	dimensionless	0		0		0.1		0.1	
View Factor of Ground	dimensionless	0		0		0.5		0.5	
Additional Service	[m]	2.0		2.0		2.0		2.0	
Liquid Tankage Mass Penalty	as a fraction	0.10		0.10		0.10		0.10	
Factor for Valves and Fittings in TCS Lines	as a fraction	0.15		0.15		0.15		0.15	
Accumulator Volume Factor	as a fraction	0.30		0.30		0.30		0.30	
Phase Change Material Container Mass	as a fraction	0		1.00		1.00		1.00	
Volume Factor for Re-Entry Containment	as a fraction	0		0.25		0.25		0.25	
Percentage of Re-Entry for Aero-Brake	as a fraction	0		0.75		0.75		0.75	
Percentage of FES Ducting Assumed	as a fraction	0		1.00		1.00		1.00	

<sup>20</sup> The avionics heat load here represents all other vehicle hardware besides life support hardware.

Table 2.4.2 Specific Input Values for Metric Mission Parameters (concluded)

Parameter	Units	ISS		Mars		Mars Descent		Surface	
		Upgrade	Value	Transit	Vehicle	Lander	Value	Lander	Habitat
External Interfaces, EVA Support									
Total Number of EVAs per Day	[sorties/d]	0	0	0	0	1	1	2	2
Crewmembers per EVA	[CM/sortie]	0	0	0	0	6	6	2	2
EVA Duration	[h]	0	0	0	0	4	4	4	4
Cooling Water Losses	[kg/CM-h]	0	0	0	0	0.19	0.19	0.19	0.19
Oxygen Losses	[kg/CM-h]	0	0	0	0	0.15	0.15	0.15	0.15
Total Airlock Volume	[m <sup>3</sup> ]	0	0	0	0	25.5	25.5	4.25	4.25
Total Number of EVAs per Mission	[sorties]	0	0	0	0	1	1	700	700
Airlock Gas Losses per Cycle	[%]	0	0	0	0	100	100	10	10
Nominal EMU Waste Water Recovery	[%]	0	0	0	0	50	50	50	50
Airlock Free Gas Volume	[m <sup>3</sup> ]	0	0	0	0	23.75	23.75	3.7	3.7
External Interfaces, Human Accommodations									
Mass of Clothing	[kg/CM-d]	0.486	0.486	0.486	0.486	0.486	0.486	0.486	0.486
Volume of Clothing	[m <sup>3</sup> /CM-d]	0.00285	0.00285	0.00285	0.00285	0.00285	0.00285	0.00285	0.00285
Computational Parameters									
Maximum Allowable Iteration Count	dimensionless	1,000	1,000	1,000	1,000	1,000	1,000	1,000	1,000
Maximum Change at Convergence	dimensionless	0.00001	0.00001	0.00001	0.00001	0.00001	0.00001	0.00001	0.00001

#### 2.4.6 INFRASTRUCTURE COSTS/EQUIVALENCIES

Infrastructure equivalencies, from Hanford (2004), are assumed as shown in Table 2.4.3 for each mission vehicle. The corresponding infrastructure technologies are noted above with each mission. With regard to both volume, which accounts for vehicle structure, and power, which represents power generation, both the ISS ECLSS and ALS technology suites use the same infrastructure equivalencies. These values are unchanged from the Fiscal Year 2003 calculation (Hanford, 2003b).

**Table 2.4.3 Advanced Mission Cost Equivalencies**

<b>Mission</b>	<b>Volume [kg/m<sup>3</sup>]</b>	<b>Power [kg/kW<sub>e</sub>]</b>	<b>Cooling<sup>21</sup> [kg/kW<sub>th</sub>]</b>
<b>Orbiting Research Facility: International Space Station Update Mission</b>	66.7	476.0	323.9
<b>Independent Exploration Mission:</b>			
Mars Transit Vehicle	9.16	237.0	40.0/ 30.0
Mars Descent / Ascent Lander	66.7	228.0	145.0/ 121.0
Surface Habitat Lander	9.16	87.0	145.0/ 121.0

For cooling, two equivalencies appear in Table 2.4.3 for each vehicle within the Independent Exploration Mission. The first cooling equivalency simulates current cooling technology using aluminum, flow-through radiators. This first equivalency is applied to assessments using the ISS ECLSS technology suite. The second cooling equivalency represents advanced radiators that are under development for life-support thermal loads. This second equivalency is applied to assessments using the ALS technology suite. All cooling equivalencies here are listed in Hanford (2004). Note that the differences between the cooling infrastructure values reflect only changes in thermal hardware material, and not changes in overall thermal management architecture.

For the International Space Station Update Mission, the same cooling equivalency, based upon current ISS cooling technology and architecture, is used for estimates employing both life support system technology suites. This approach is equivalent to assuming that ISS cooling technology is unlikely to change regardless of which technologies supply life support functions within ISS.

<sup>21</sup> When two infrastructure equivalencies are listed for cooling, the first assumes current technology using aluminum, flow-through radiators, while the second assumes advanced technologies with some form of lightweight radiators.

### 3 ADVANCED LIFE SUPPORT RESEARCH AND TECHNOLOGY DEVELOPMENT METRIC

#### 3.1 SUBSYSTEM TECHNOLOGY DATA

The tables below list overall subsystem attributes for the various vehicles and missions considered in this Metric computation. Except as noted above, these classifications are consistent with ALS terminology as presented within Hanford (2004) and Stafford, *et al.* (2001).

**Table 3.1.1 Orbiting Research Facility: International Space Station Upgrade Mission using ISS ECLSS Technologies**

Subsystem / Interface	Mass [kg]	Volume [m <sup>3</sup> ]	Power [kW <sub>e</sub> ]	Cooling [kW <sub>th</sub> ]	Crewtime [CM-h]	ESM [kg]
Air	33,200	35.07	4.50	2.87	129.58	38,685
Biomass	0	0.00	0.00	0.00	0.00	0
Food	30,049	119.96	2.93	2.93	0.00	40,394
Thermal	750	2.67	0.77	0.77	20.28	1,556
Waste	3,410	93.84	0.01	0.01	0.00	9,677
Water	26,451	14.40	1.35	1.35	0.00	28,491
Extravehicular Activity Support	0	0.00	0.00	0.00	0.00	0
Human Accommodations	17,871	69.64	0.00	0.00	0.00	22,516
<b>Totals</b>	<b>111,731</b>	<b>335.58</b>	<b>9.56</b>	<b>7.93</b>	<b>149.86</b>	

The total life support system ESM for the International Space Station Upgrade Mission using ISS ECLSS technologies, rounded to the nearest 10 kg, is 141,320 kg. The computed crewtime-mass penalty for this assessment is 0.573 kg/CM-h.

**Table 3.1.2 Orbiting Research Facility: International Space Station Upgrade Mission using ALS Technologies**

Subsystem / Interface	Mass [kg]	Volume [m <sup>3</sup> ]	Power [kW <sub>e</sub> ]	Cooling [kW <sub>th</sub> ]	Crewtime [CM-h]	ESM [kg]
Air	11,429	16.09	6.15	4.52	129.58	16,931
Biomass	0	0.00	0.00	0.00	0.00	0
Food	24,002	105.79	0.96	0.96	0.00	31,826
Thermal	765	2.70	0.77	0.77	20.28	1,567
Waste	1,477	38.06	1.44	1.44	973.33	5,452
Water	2,308	2.06	3.80	1.88	0.00	4,863
Extravehicular Activity Support	0	0.00	0.00	0.00	0.00	0
Human Accommodations	7,799	10.06	0.63	0.63	0.00	8,974
<b>Totals</b>	<b>47,780</b>	<b>174.76</b>	<b>13.75</b>	<b>10.20</b>	<b>1,123.19</b>	

The total life support system ESM for the International Space Station Upgrade Mission using ALS technologies, rounded to the nearest 10 kg, is 69,610 kg. The computed crewtime-mass penalty for this assessment is 0.292 kg/CM-h.



**Table 3.1.3 Independent Exploration Mission: Mars Transit Vehicle using ISS ECLSS Technologies**

Subsystem / Interface	Mass [kg]	Volume [m <sup>3</sup> ]	Power [kW <sub>e</sub> ]	Cooling [kW <sub>th</sub> ]	Crewtime [CM-h]	ESM [kg]
Air	2,217	3.37	4.35	2.79	12.78	3,401
Biomass	761	17.03	12.03	12.03	0.00	4,249
Food	4,158	15.12	2.40	2.40	0.00	4,961
Thermal	369	1.09	1.07	1.07	2.00	677
Waste	393	10.03	0.01	0.01	0.00	488
Water	2,587	4.18	1.00	1.00	0.00	2,902
Extravehicular Activity Support	0	0.00	0.00	0.00	0.00	0
Human Accommodations	1,763	6.87	0.00	0.00	0.00	1,826
<b>Totals</b>	<b>12,248</b>	<b>57.69</b>	<b>20.86</b>	<b>19.30</b>	<b>14.78</b>	

The total life support system ESM for the Mars Transit Vehicle in the Independent Exploration Mission using ISS ECLSS technologies, rounded to the nearest 10 kg, is 18,500 kg. The computed crewtime-mass penalty for this assessment is 0.815 kg/CM-h.

**Table 3.1.4 Independent Exploration Mission: Mars Transit Vehicle using ALS Technologies**

Subsystem / Interface	Mass [kg]	Volume [m <sup>3</sup> ]	Power [kW <sub>e</sub> ]	Cooling [kW <sub>th</sub> ]	Crewtime [CM-h]	ESM [kg]
Air	1,345	3.04	5.49	3.93	12.78	2,800
Biomass	761	17.03	12.03	12.03	0.00	4,129
Food	2,109	8.16	0.96	0.96	0.00	2,440
Thermal	374	1.10	1.10	1.10	2.00	679
Waste	256	6.24	0.01	0.01	0.00	316
Water	991	2.40	4.18	2.01	0.00	2,064
Extravehicular Activity Support	0	0.00	0.00	0.00	0.00	0
Human Accommodations	863	1.36	0.63	0.63	0.00	1,044
<b>Totals</b>	<b>6,699</b>	<b>39.33</b>	<b>24.40</b>	<b>20.67</b>	<b>14.78</b>	

The total life support system ESM for the Mars Transit Vehicle in the Independent Exploration Mission using ALS technologies, rounded to the nearest 10 kg, is 13,470 kg. The computed crewtime-mass penalty for this assessment is 0.617 kg/CM-h.

**Table 3.1.5 Independent Exploration Mission: Mars Descent / Ascent Lander using ISS ECLSS Technologies**

Subsystem / Interface	Mass [kg]	Volume [m <sup>3</sup> ]	Power [kW <sub>e</sub> ]	Cooling [kW <sub>th</sub> ]	Crewtime [CM-h]	ESM [kg]
Air	1,130	2.28	4.34	2.79	1.07	2,680
Biomass	0	0.00	0.00	0.00	0.00	0
Food	302	1.15	1.86	1.86	0.00	1,072
Thermal	295	0.93	0.82	0.82	0.17	663
Waste	64	0.90	0.01	0.01	0.00	128
Water	742	2.87	0.90	0.90	0.00	1,269
Extravehicular Activity Support	22	0.25	0.00	0.00	0.00	39
Human Accommodations	147	0.57	0.00	0.00	0.00	185
<b>Totals</b>	<b>2,702</b>	<b>8.95</b>	<b>7.93</b>	<b>6.38</b>	<b>1.24</b>	

The total life support system ESM for the Mars Descent / Ascent Lander in the Independent Exploration Mission using ISS ECLSS technologies, rounded to the nearest 10 kg, is 6,040 kg. The computed crewtime-mass penalty for this assessment is 3.284 kg/CM-h.

**Table 3.1.6 Independent Exploration Mission: Mars Descent / Ascent Lander using ALS Technologies**

Subsystem / Interface	Mass [kg]	Volume [m <sup>3</sup> ]	Power [kW <sub>e</sub> ]	Cooling [kW <sub>th</sub> ]	Crewtime [CM-h]	ESM [kg]
Air	687	1.00	0.79	0.79	0.01	1,029
Biomass	0	0.00	0.00	0.00	0.00	0
Food	190	0.92	0.96	0.96	0.00	586
Thermal	278	0.89	0.78	0.78	0.17	610
Waste	65	0.91	0.01	0.01	0.00	129
Water	675	2.77	0.88	0.88	0.00	1,167
Extravehicular Activity Support	22	0.25	0.00	0.00	0.00	39
Human Accommodations	147	0.57	0.00	0.00	0.00	185
<b>Totals</b>	<b>2,064</b>	<b>7.31</b>	<b>3.42</b>	<b>3.42</b>	<b>0.18</b>	

The total life support system ESM for the Mars Descent / Ascent Lander in the Independent Exploration Mission using ALS technologies, rounded to the nearest 10 kg, is 3,750 kg. The computed crewtime-mass penalty for this assessment is 2.040 kg/CM-h.

**Table 3.1.7 Independent Exploration Mission: Surface Habitat Lander using ISS ECLSS Technologies**

Subsystem / Interface	Mass [kg]	Volume [m <sup>3</sup> ]	Power [kW <sub>e</sub> ]	Cooling [kW <sub>th</sub> ]	Crewtime [CM-h]	ESM [kg]
Air	4,047	5.35	5.59	3.41	21.30	5,093
Biomass	898	17.03	12.03	12.03	0.00	3,845
Food	6,032	22.39	2.40	2.40	0.00	6,794
Thermal	406	1.22	1.18	1.18	3.33	693
Waste	686	18.16	0.01	0.01	0.00	855
Water	9,154	8.50	1.16	1.16	0.00	9,501
Extravehicular Activity Support	1,292	2.92	2.50	2.50	0.00	1,899
Human Accommodations	2,938	11.45	0.00	0.00	0.00	3,043
<b>Totals</b>	<b>25,453</b>	<b>87.02</b>	<b>24.87</b>	<b>22.69</b>	<b>24.63</b>	

The total life support system ESM for the Surface Habitat Lander in the Independent Exploration Mission using ISS ECLSS technologies, rounded to the nearest 10 kg, is 31,720 kg. The computed crewtime-mass penalty for this assessment is 0.757 kg/CM-h.

**Table 3.1.8 Independent Exploration Mission: Surface Habitat Lander using ALS Technologies**

Subsystem / Interface	Mass [kg]	Volume [m <sup>3</sup> ]	Power [kW <sub>e</sub> ]	Cooling [kW <sub>th</sub> ]	Crewtime [CM-h]	ESM [kg]
Air	2,781	4.52	6.16	4.60	21.30	3,924
Biomass	898	17.03	12.03	12.03	0.00	3,556
Food	3,491	13.52	0.96	0.96	0.00	3,815
Thermal	421	1.25	1.28	1.28	3.33	700
Waste	410	8.22	1.56	1.56	160.00	878
Water	1,082	2.44	4.22	2.02	0.00	1,716
Extravehicular Activity Support	1,130	2.57	1.00	1.00	0.00	1,362
Human Accommodations	1,349	1.87	0.63	0.63	0.00	1,497
<b>Totals</b>	<b>11,562</b>	<b>51.42</b>	<b>27.84</b>	<b>24.08</b>	<b>184.63</b>	

The total life support system ESM for the Surface Habitat Lander in the Independent Exploration Mission using ALS technologies, rounded to the nearest 10 kg, is 17,450 kg. The computed crewtime-mass penalty for this assessment is 0.428 kg/CM-h.

## 3.2 ADVANCED LIFE SUPPORT RESEARCH AND TECHNOLOGY DEVELOPMENT METRIC

### 3.2.1 METRIC VALUES

Metric values were calculated for each of the mission vehicles described above. The ESM for each mission segment was estimated separately by applying the appropriate equivalencies or cost factors. The mission segment ESM values were summed to derive a total vehicle ESM. The vehicle ESM values were also summed to provide an overall mission ESM. Metrics were calculated for each vehicle and mission by dividing the ESM for the life support system using ISS ECLSS technologies by the corresponding ESM for the life support system using ALS technologies. Different extravehicular activity models were used for the various vehicles, as applicable. The results are tabulated in Table 3.2.1.

As noted earlier, the International Space Station mission employs a single vehicle here, thus the mission and the vehicle are equivalent. The Mars Independent Exploration mission uses three different vehicles to place a single crew on Mars and return that crew safely to Earth. The overall mission ESM and Metric are listed on the first line, and the individual vehicle ESM and Metric values are listed on the lines below.

**Table 3.2.1 Equivalent System Mass and Metric Values for a Range of Missions and Technologies**

Mission / Vehicle	ISS ECLSS Technology ESM [kg]	ALS Technology ESM [kg]	ALS R&TD Metric
<b>Orbiting Research Facility: International Space Station Upgrade Mission</b>	<b>141,320</b>	<b>69,610</b>	<b>2.03</b>
<b>Independent Exploration Mission:</b>	<b>56,260</b>	<b>34,670</b>	<b>1.62</b>
Mars Transit Vehicle	18,500	13,470	1.37
Mars Descent / Ascent Lander	6,040	3,750	1.61
Surface Habitat Lander	31,720	17,450	1.82

Table 3.2.1 with Figure 3.3.1 and Figure 3.3.2 summarize calculations supporting the Fiscal Year 2004 Advanced Life Support Research and Technology Development Metric. Figure 3.3.1 presents the overall equivalent masses for both reference missions used for the Fiscal Year 2004 Metric, while Figure 3.3.2 provides equivalent masses for each of the vehicles within the Independent Exploration Mission.

### 3.2.2 DISCUSSION

Examination of Figure 3.3.1, which provides a graphical breakdown of equivalent system mass by subsystem, reveals that food, water, and air are again the most massive subsystems within the life support system. The human accommodations external interface, which represents clothing primarily, can also be significant. The advanced configurations reduce most subsystem masses.

The current evaluation, which considered several ALS technology suites within ALSSAT, selected several technologies over the range of vehicles and mission durations. For the air subsystem, carbon dioxide reduction, via Sabatier, was more economical for all vehicles except the relatively short-duration vehicle, the Mars Descent/Ascent Lander. Cryogenic gas storage was also widely beneficial because high-pressure gases require fairly thick and, therefore, heavy, containment vessels. Interestingly, stored oxygen was more economical than producing oxygen by electrolysis of water for the short-duration Mars Descent / Ascent Lander.

The baseline frozen food system was heavier in all cases than a shelf-stable, ambient storage food system. Additionally, though not evident in the values here, a salad machine is only reasonable if required by mission protocols, because current assessments and hardware are not frugal enough to reduce the life

support system costs simply based on other benefits of a small biomass production chamber. This, however, is consistent with other assessments.

For the waste subsystem, long duration missions benefit from water recovery via warm-air drying and/or lyophilization. The Mars Transit Vehicle does not benefit from reclaiming water from waste for several reasons. Firstly, the ALS water subsystem has high recovery of input grey water streams. Secondly, water is released to the vehicle water stores from moisture in the prepackaged food and by metabolic action of the crew. Thirdly, the Mars Transit Vehicle does not lose any water directly from its water stores due to experiments or extravehicular activities.

For the water subsystem, vapor phase catalytic ammonia removal was significantly more economical for longer duration mission segments than the current ISS ECLSS water-processing suite based on multifiltration even after accounting for greater power consumption. The ISS ECLSS water-processing suite was, however, less massive than vapor phase catalytic ammonia removal for the short-duration Mars Descent / Ascent Lander.

### 3.3 METRIC REPORTING RECOMMENDATIONS

#### 3.3.1 METRIC RECOMMENDATION FOR FISCAL YEAR 2004

It is recommended that the following values of the Advanced Life Support Research and Technology Development Metric be reported to the Office of Biological and Physical Research and the Advanced Human Support Technology Program for Government Fiscal Year 2004:

Orbiting Research Facility:	2.03
Independent Exploration Mission:	1.62

#### 3.3.2 COMPARISON WITH PAST ASSESSMENTS

Table 3.3.1 provides recent values of the Advanced Life Support Research and Technology Development Metric with associated sources. These values are plotted in Figure 3.3.3. Please note that each annual assessment to date, though similar in overall approach, has really been unique in one or more ways when compared to the other assessments, so the progressions of values are not directly comparable.

**Table 3.3.1 Previous Advanced Life Support Research and Technology Development Metric Values**

Mission	Government Fiscal Year				References
	2001	2002	2003	2004	
Orbiting Research Facility	1.32 <sup>(1)</sup>	1.53 <sup>(2)</sup>	1.47 <sup>(3)</sup>	2.03 <sup>(4)</sup>	(1) Drysdale and Hanford (2002) (2) Hanford (2003a) (3) Hanford (2003b) (4) This document
Independent Exploration Mission	1.28 <sup>(1)</sup>	1.37 <sup>(2)</sup>	1.36 <sup>(3)</sup>	1.62 <sup>(4)</sup>	

The values in Table 3.3.1 generally increase as a function of time for both reference missions. The increases over last year can be divided into two effects: technology and methodology. Considering technology, cryogenic gas storage substantially reduced masses associated with commodities for the air subsystem. Considering methodology, assuming a frozen food system in all baseline configurations slightly increased the equivalent system mass of some baseline configurations. More substantially, removing dry food, which is essentially a constant mass, from both baseline and advanced configurations probably provided a greater increase in the Metric values.

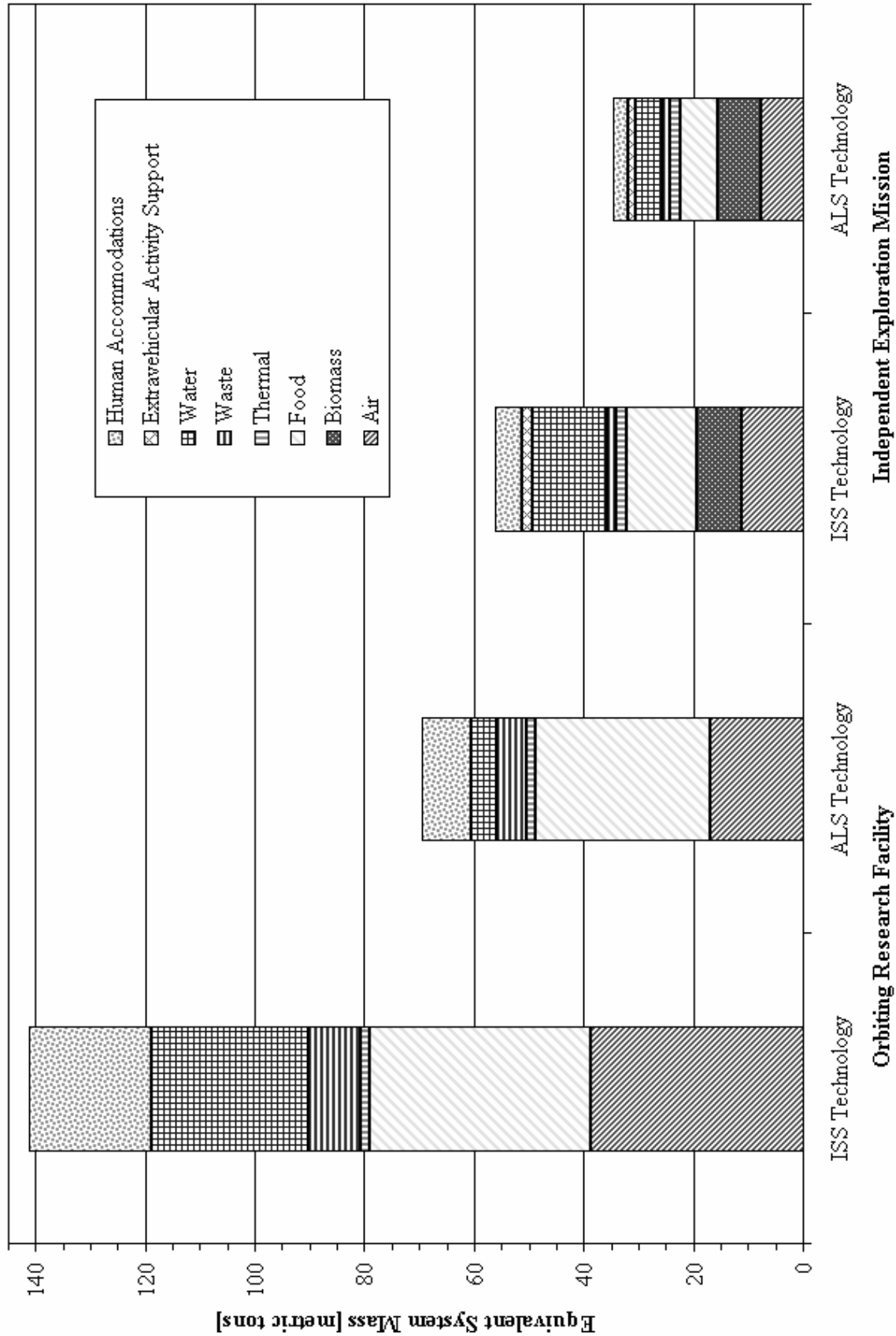

Figure 3.3.1 Equivalent system mass summary for the Fiscal Year 2004 ALS Research and Technology Development Metric missions and technology suites.

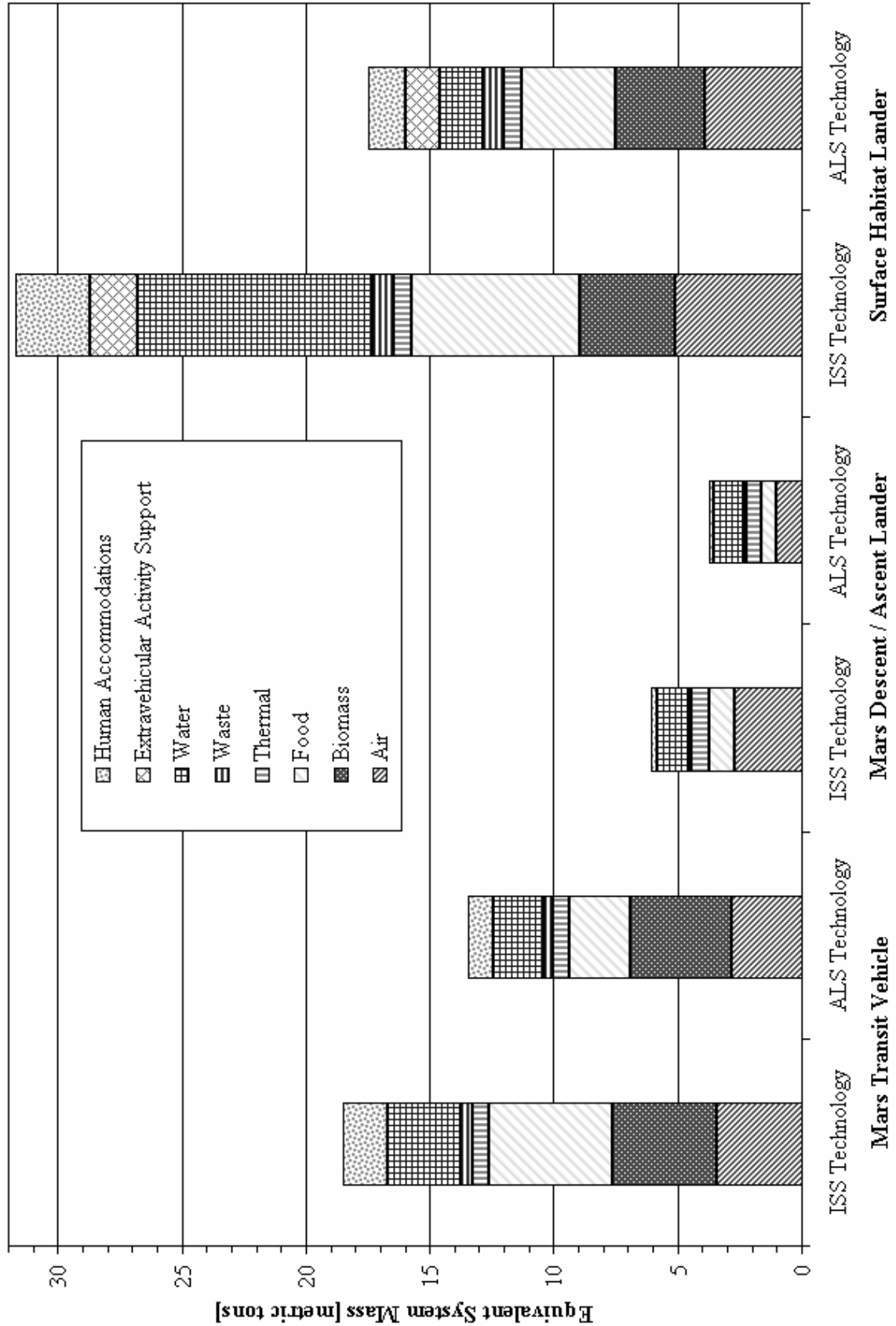

Figure 3.3.2 Equivalent system mass summary for the components of the Independent Exploration Mission.

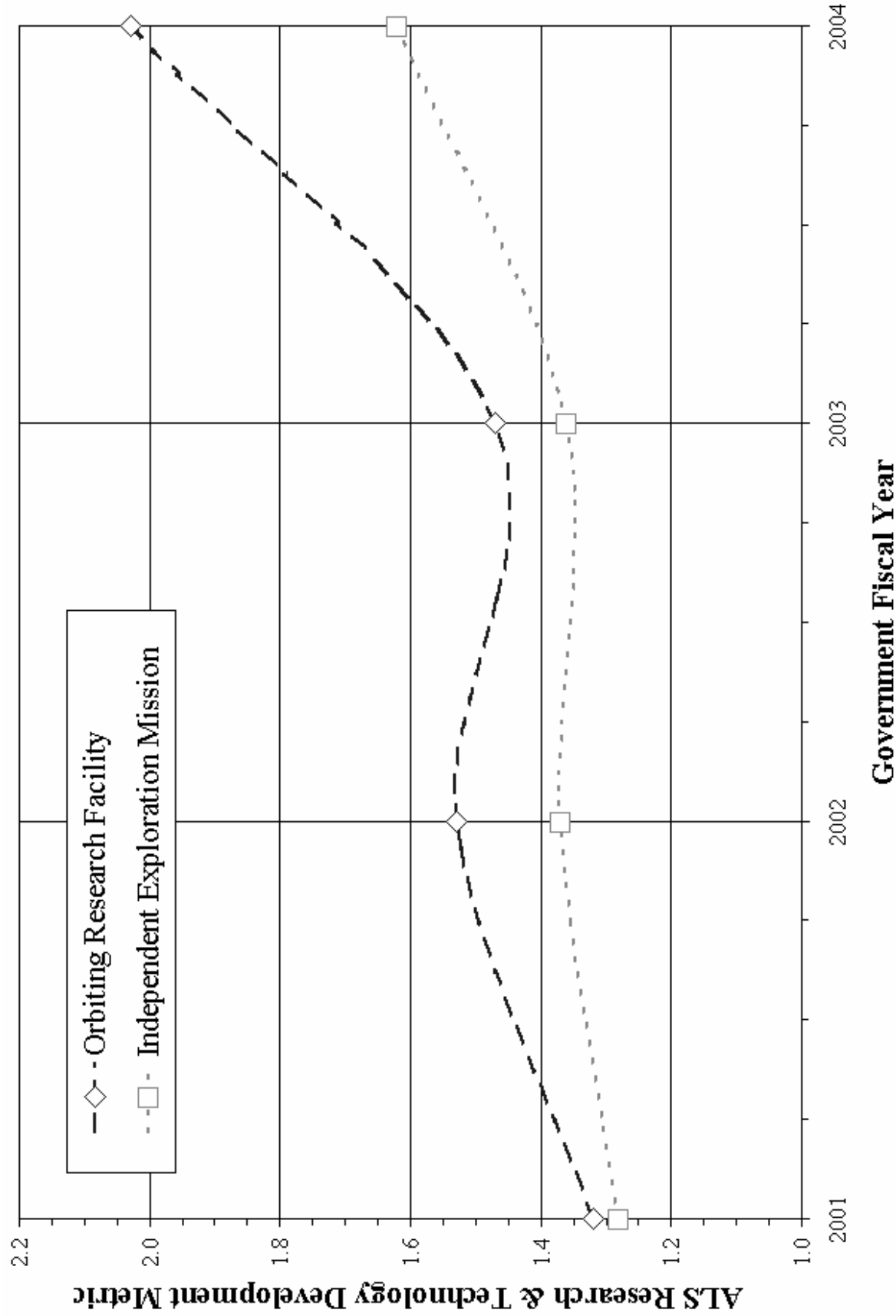

Figure 3.3.3 Historical progression of Advanced Life Support Research and Technology Development Metric values as a function of Fiscal Year.



## 4 CAUTIONS AND DISCLAIMERS

This type of analysis includes several inescapable sources of variation from actual flight systems. The first is that these estimations fail to consider contingency or redundancy in any detail. Further, inclusion of contingency or redundancy invariably increases the overall equivalent system mass of all configurations, although this may have little significant impact on the overall conclusions and, therefore, the implied direction, above. The second source of uncertainty, which is related to the first, is that all calculations above use only single-string life support system architecture. Multi-string systems, where each life support processor is sized to handle a larger load should one processor fail, are essential to meeting actual flight requirements for safety. Because processor physical attributes do not, in general, scale linearly with capacity, two processors in place of one will be more massive, even excluding the extra capability to insure redundancy. Again, this impact would apply to all configurations; therefore, it may not affect the direction implied above. The third source of uncertainty resides in the preliminary nature of the data employed for the ALS equipment. While it is desirable that flight equipment will be more economical than the values assumed here, it is possible that real systems may actually be less economical due to unforeseen difficulties during development or added components to assure safe operation in the flight environment. Fourthly, as ALS research and technology development continues, new technologies and architectural ideas may drastically change current doctrine about providing life support, producing profound savings for future human spaceflight. Thus, these estimates should be considered preliminary and not definitive, although they provide one measure of where NASA and the ALS Project are today.

## 5 SPECIAL RECOGNITION OF WORK

The author would like to thank many people, both within and outside of NASA, for their thoughts and input into both what is presented above and what has come before. Many metric formulations were considered by a group of life support analysts and researchers, and it is due to their excellent input that the Metric now exists in its current form. In particular, Dr. A. E. Drysdale of The Boeing Company deserves recognition for developing equivalent system mass in its current form for the ALS Project and guiding the Metric in previous years.

For compiling an archival source detailing the current definition of equivalent system mass, special recognition is due J. A. Levri of Ames Research Center.

For the current work, the author especially recognizes J. Yeh and C. Brown of Lockheed Martin Space Operations, Houston, Texas, for their continuing support of the Advanced Life Support Sizing Analysis Tool during the computation of the Metric.

This document is available electronically from the Advanced Life Support Project of the National Aeronautics and Space Administration at Lyndon B. Johnson Space Center at:

*<http://advlifesupport.jsc.nasa.gov/>*

## 6 REFERENCES

- Drysdale, A. E., and Hanford, A. J. (2002) "Advanced Life Support Research and Technology Development Metric – Fiscal Year 2001," JSC 47787 (CTSD-ADV-482), National Aeronautics and Space Administration, Lyndon B. Johnson Space Center, Houston, Texas, 17 January 2002.
- Hanford, A. J. (2003a) "Advanced Life Support Research and Technology Development Metric - Fiscal Year 2002," JSC 60313 (CTSD-ADV-510), Revision A, National Aeronautics and Space Administration, Lyndon B. Johnson Space Center, Houston, Texas, 24 July 2003.
- Hanford, A. J. (2003b) "Advanced Life Support Research and Technology Development Metric - Fiscal Year 2003," NASA/CR-2004-208939 (JSC 60455, CTSD-ADV-524), National Aeronautics and Space Administration, Lyndon B. Johnson Space Center, Houston, Texas, 30 September 2003.
- Hanford, A. J., Editor (2004) "Advanced Life Support Baseline Values and Assumptions Document," NASA/CR-2004-208941 (JSC 47804 A, CTSD-ADV-484 A), National Aeronautics and Space Administration, Lyndon B. Johnson Space Center, Houston, Texas.
- Henninger, D. L., *et al.* (2002) "Advanced Life Support Project Plan," JSC 39168 (CTSD-ADV-348), Revision C, National Aeronautics and Space Administration, Lyndon B. Johnson Space Center, Houston, Texas.
- Levri, J. A., Drysdale, A. E., Ewert, M. K., Fisher, J. W., Hanford, A. J., Hogan, J. A., Jones, H. W., Joshi, J. A., and Vaccari, D. A. (2003) "Advanced Life Support Equivalent System Mass Guidelines Document," NASA/TM-2003-212278, National Aeronautics and Space Administration, Ames Research Center, Moffett Field, California.
- Stafford, K. W., Jerng, L. T., Drysdale, A. E., Maxwell, S., Levri, J. A., Ewert, M. K., and Hanford, A. J. (2001) "Advanced Life Support Systems Integration, Modeling, and Analysis Reference Missions Document," JSC 39502, Revision A, National Aeronautics and Space Administration, Lyndon B. Johnson Space Center, Houston, Texas.
- Yeh, J., Brown, C., and Jeng, F. (2002) "Advanced Life Support Sizing Analysis Tool (ALSSAT) v.2.0 User's Guide," LMSEAT 34082, Lockheed Martin Space Operations, Houston, Texas.
- Yeh, J., Brown, C., and Jeng, F. (2003) "Advanced Life Support Sizing Analysis Tool (ALSSAT) v.3.0," MSAD-03-0279, Lockheed Martin Space Operations, Houston, Texas.
- Yeh, J., Brown, C., and Jeng, F. (2004) "FY04 ALSSAT Upgrade," MSAD-04-0261, Lockheed Martin Space Operations, Houston, Texas.

## 7 ABBREVIATIONS AND ACRONYMS

4BMS	four-bed molecular sieve	kPa	kilo Pascal ( <i>i.e.</i> , units of pressure.)
AAA	avionic air assembly	kW <sub>e</sub>	kilo Watt, electric ( <i>i.e.</i> , units of electric power.)
AES	air evaporation subsystem	kW <sub>th</sub>	kilo Watt, thermal ( <i>i.e.</i> , units of heat transfer rate.)
A/L	airlock	m	meter ( <i>i.e.</i> , units of length)
ALS	Advanced Life Support	m <sup>3</sup>	cubic meters ( <i>i.e.</i> , units of volume.)
ALSSAT	Advanced Life Support Sizing Analysis Tool	MCA	major constituent analyzer
AS	ambient storage	MCV	microbial check valve
ATCO	ambient temperature catalytic oxidizer (for carbon monoxide removal)	MF	multifiltration
CCAA	common cabin air assembly	MJ	mega Joule ( <i>i.e.</i> , units of energy.)
CH <sub>4</sub>	methane	MLS	mostly liquid separator
CM	crewmember ( <i>i.e.</i> , units for enumerating people)	mod	modules ( <i>i.e.</i> , units for enumerating modules)
CM-d	crewmember-day ( <i>i.e.</i> , the time from one crewmember for one day.)	N <sub>2</sub>	nitrogen
CM-h	crewmember-hour ( <i>i.e.</i> , the time from one crewmember for one hour.)	NASA	National Aeronautics and Space Administration
CO <sub>2</sub>	carbon dioxide	O <sub>2</sub>	oxygen
Cond. HX	anti-microbial condensing heat exchanger	OGA	oxygen generation assembly
Cond. Tank	condensate tank	ORCA	oxygen recharge compressor assembly
d	day ( <i>i.e.</i> , units of time.)	pH	potential of hydrogen
ECLSS	environmental control and life support system	RFR	refrigerator freezer rack
EMU	extravehicular mobility unit	SAVD	solid amine vacuum desorption
ESM	equivalent system mass	SIMA	Systems Integration, Modeling, and Analysis Project Element
EVA	extravehicular activity	TCCS	trace contaminant control subsystem
FDS	fire detection and suppression	TCS	thermal control subsystem
G/L	gas/liquid (separator)	TRL	technology readiness level (See Table 1.2.1)
h	hour ( <i>i.e.</i> , units of time)	USOS	United States On-Orbit Segment (of the International Space Station)
H <sub>2</sub>	hydrogen	VCD	vapor compression distillation
H <sub>2</sub> O	water	VPCAR	vapor phase catalytic ammonia removal
H <sub>2</sub> SO <sub>4</sub>	sulfuric acid	VRA	volatile removal assembly
HEPA	high efficiency particulate air	WW	wastewater (tank)
HP	high-pressure (gas)		
HX	heat exchanger		
ITCS	internal thermal control system		
ISS	International Space Station		
IX	ion exchange		
kg	kilogram ( <i>i.e.</i> , units of mass.)		

REPORT DOCUMENTATION PAGE			Form Approved OMB No. 0704-0188	
Public reporting burden for this collection of information is estimated to average 1 hour per response, including the time for reviewing instructions, searching existing data sources, gathering and maintaining the data needed, and completing and reviewing the collection of information. Send comments regarding this burden estimate or any other aspect of this collection of information, including suggestions for reducing this burden, to Washington Headquarters Services, Directorate for Information Operations and Reports, 1215 Jefferson Davis Highway, Suite 1204, Arlington, VA 22202-4302, and to the Office of Management and Budget, Paperwork Reduction Project (0704-0188), Washington, DC 20503.				
1. AGENCY USE ONLY (Leave Blank)	2. REPORT DATE October 2004	3. REPORT TYPE AND DATES COVERED NASA Contractor Report		
4. TITLE AND SUBTITLE Advanced Life Support Research and Technology Development Metric – Fiscal Year 2004			5. FUNDING NUMBERS	
6. AUTHOR(S) A. J. Hanford, PhD.				
7. PERFORMING ORGANIZATION NAME(S) AND ADDRESS(ES) Lyndon B. Johnson Space Center Houston, Texas 77058			8. PERFORMING ORGANIZATION REPORT NUMBERS S-940	
9. SPONSORING/MONITORING AGENCY NAME(S) AND ADDRESS(ES) National Aeronautics and Space Administration Washington, DC 20546-0001			10. SPONSORING/MONITORING AGENCY REPORT NUMBER CR-2004-208944	
11. SUPPLEMENTARY NOTES				
12a. DISTRIBUTION/AVAILABILITY STATEMENT Available from the NASA Center for AeroSpace Information (CASI) 7121 Standard Hanover, MD 21076-1320 Category: 54			12b. DISTRIBUTION CODE	
13. ABSTRACT (Maximum 200 words) The Metric is one of several measures employed by the NASA to assess the Agency's progress as mandated by the United States Congress and the Office of Management and Budget. Because any measure must have a reference point, whether explicitly defined or implied, the Metric is a comparison between a selected ALS Project life support system and an equivalently detailed life support system using technology from the Environmental Control and Life Support System (ECLSS) for the International Space Station (ISS). This document provides the official calculation of the Advanced Life Support (ALS) Research and Technology Development Metric (the Metric) for Fiscal Year 2004. The values are primarily based on Systems Integration, Modeling, and Analysis (SIMA) Element approved software tools or reviewed and approved reference documents. For Fiscal Year 2004, the Advanced Life Support Research and Technology Development Metric value is 2.03 for an Orbiting Research Facility and 1.62 for an Independent Exploration Mission.				
14. SUBJECT TERMS life support system; life support system, environments; environmental control; systems integration			15. NUMBER OF PAGES 54	16. PRICE CODE
17. SECURITY CLASSIFICATION OF REPORT Unclassified	18. SECURITY CLASSIFICATION OF THIS PAGE Unclassified	19. SECURITY CLASSIFICATION OF ABSTRACT Unclassified	20. LIMITATION OF ABSTRACT Unlimited	



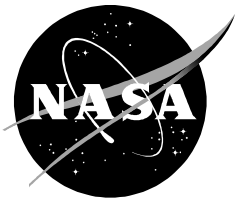

National Aeronautics and  
Space Administration

**Lyndon B. Johnson Space Center**  
Houston, Texas