

CONFIDENTIAL
CLASSIFICATION CANCELLED

Copy /
RM SL53G27

REC'D JUL 24 1953

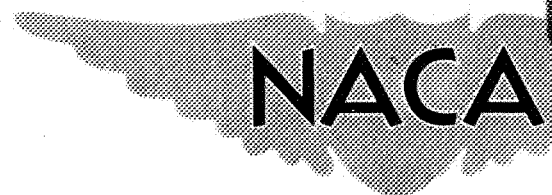

CLASSIFICATION CANCELLED

Advisory, NACA MEMORANDUM, RESEARCH
AND INVESTIGATION NOTES No. 102

Restriction/
Classification
Cancelled

LE

RESEARCH MEMORANDUM

for the

Bureau of Aeronautics, Department of the Navy

WIND-TUNNEL INVESTIGATION AT LOW SPEED OF THE PITCHING
STABILITY DERIVATIVES OF A 1/9-SCALE POWERED MODEL
OF THE CONVAIR XFY-1 VERTICALLY RISING AIRPLANE

TED NO. NACA DE 373

By M. J. Queijo, Walter D. Wolhart, and H. S. Fletcher

Langley Aeronautical Laboratory
Langley Field, Va.

CLASSIFIED DOCUMENT
CLASSIFICATION CANCELLED

This material contains information of a classified nature whose disclosure in any form within the meaning of the espionage laws, Title 18, U.S.C., Secs. 793 and 794, the transmission or revelation of which in any manner to an unauthorized person is prohibited by law.

NATIONAL ADVISORY COMMITTEE FOR AERONAUTICS

WASHINGTON
JUL 23 1953

FILE COPY
To be returned to
the files of the National
Advisory Committee
for Aeronautics
Washington, D. C.

16

CONFIDENTIAL
CLASSIFICATION CANCELLED



NATIONAL ADVISORY COMMITTEE FOR AERONAUTICS

RESEARCH MEMORANDUM

for the

Bureau of Aeronautics, Department of the Navy

WIND-TUNNEL INVESTIGATION AT LOW SPEED OF THE PITCHING

STABILITY DERIVATIVES OF A 1/9-SCALE POWERED MODEL

OF THE CONVAIR XFY-1 VERTICALLY RISING AIRPLANE

TED NO. NACA DE 373

By M. J. Queijo, Walter D. Wolhart, and H. S. Fletcher

SUMMARY

An experimental investigation has been conducted in the Langley stability tunnel at low speed to determine the pitching stability derivatives of a 1/9-scale powered model of the Convair XFY-1 vertically rising airplane. Effects of thrust coefficient, control deflections, and propeller blade angle were investigated. The tests were made through an angle-of-attack range from about -4° to 29° , and the thrust coefficient range was from 0 to 0.7.

In order to expedite distribution of these data, no analysis of the data has been prepared for this paper.

INTRODUCTION

Various investigations have shown that the dynamic stability characteristics of high-speed aircraft are critically dependent on certain mass and aerodynamic parameters and, hence, that reliable estimates of the dynamic stability of such aircraft can be made only if these parameters are determined accurately. The purpose of the present investigation was to determine the pitching stability derivatives of a powered model of the Convair XFY-1 vertically rising airplane from a series of low-speed tests in the Langley stability tunnel. These tests were made at the request of the Bureau of Aeronautics to aid in the development of the XFY-1 airplane. The results of previous investigations to determine the

static longitudinal and lateral stability derivatives, the yawing stability derivatives, and the rolling stability derivatives of the same model are given in references 1, 2, and 3, respectively.

SYMBOLS AND COEFFICIENTS

The data presented herein are in the form of standard NACA coefficients of forces and moments which are referred to the system of stability axes (fig. 1) with the origin at the projection of the 14-percent wing mean aerodynamic chord on the plane of symmetry. This system of axes is defined as an orthogonal system having the origin at the assumed center of gravity and in which the Z-axis is in the plane of symmetry and perpendicular to the relative wind, the X-axis is in the plane of symmetry and perpendicular to the Z-axis, and the Y-axis is perpendicular to the plane of symmetry. Positive directions of forces, moments, and displacements are shown in figure 1.

b	theoretical wing span, 2.86 ft
d	local propeller blade chord, ft
\bar{c}	wing mean aerodynamic chord
h	maximum blade thickness at local chord, ft
D	propeller diameter, ft
q	dynamic pressure, $\frac{1}{2} \rho V^2$, lb/sq ft; or pitching angular velocity, radians/sec
r_0	radial distance from propeller hub center line, ft
R	propeller radius, 0.889 ft
S	area of theoretical wing, 4.27 sq ft
V	free-stream velocity, ft/sec
α	wing angle of attack, deg
β	sideslip angle, radians
$(\beta_0)_F$	front propeller blade angle measured at $0.75R$, deg
γ	angle of climb, deg

δ_e	elevator deflection, positive trailing edge down, deg
δ_R	rudder deflection, positive trailing edge to left, deg
ψ	angle of yaw, deg
θ	local blade angle, deg
ϕ	angle of roll, deg
ρ	mass density of air, slugs/cu ft
L	lift, lb
X	longitudinal force, lb
Y	side force, lb
T	thrust, lb ($T = X_{\text{propellers on}} - X_{\text{propellers off}}$ for complete model at $\alpha = 0^\circ$)
M	pitching moment, ft-lb
N	yawing moment, ft-lb
l	rolling moment, ft-lb
C_L	lift coefficient, L/qS
T_c	thrust coefficient, T/qS
C_m	pitching-moment coefficient, $M/qS\bar{c}$
$\frac{q\bar{c}}{2V}$	pitching-velocity parameter

$$C_{Lq} = \frac{\partial C_L}{\partial \frac{q\bar{c}}{2V}}$$

$$C_{mq} = \frac{\partial C_m}{\partial \frac{q\bar{c}}{2V}}$$

Subscripts:

F front
L left
R right

MODEL AND APPARATUS

The model used in this investigation was a 1/9-scale powered model of the Convair XFY-1 vertically rising airplane. Pertinent geometric characteristics of the model are given in figure 2. The wing was built around a core made from 1/2-inch-thick duralumin sheet and was built up to the proper contour with laminated mahogany. The fuselage and fins were constructed of laminated mahogany. All control surfaces were made of solid duralumin. The wing and fins had modified NACA 63-009 airfoil contours parallel to the model thrust line.

The propeller blades, for which the geometric characteristics are given in figure 3, were constructed of heat-treated duralumin and were driven by a 50-horsepower water-cooled motor. The motor was equipped with a dual-rotating gear box. Power for the model motor was supplied by a 75-kilowatt motor-generator set, which is part of the equipment of the Langley stability tunnel. Propeller speeds were measured by means of a Strobocorr unit in conjunction with an alternator driven directly by the model motor.

A two-strut support system was used to attach the model to a six-component balance system. Photographs of the model mounted on the struts are given as figure 4. All tests were made in the Langley stability tunnel in which pitching flow is simulated by curving the airstream about a stationary model (ref. 4).

TESTS

The tests of the present investigation were made at a dynamic pressure of 16 pounds per square foot, which corresponds to a Mach number of about 0.11 and a Reynolds number of 1.28×10^6 based on the wing mean aerodynamic chord of 1.73 feet. Most of the tests were made with controls in the neutral position and with the front blades set at $(\beta_0)_F = 25^\circ$.

A few tests were made to determine effects of blade angle on the pitching stability derivatives. In all cases the rear propeller blades were set at

1° less than the front blades. Effects of control deflections also were investigated. The characteristics of the model with propellers removed also were investigated.

Tests were made at values of $q\bar{c}/2V$ of about 0, 0.0170, 0.0352, and 0.0495. Power-on data were obtained for several thrust coefficients from 0 to 0.7. The thrust coefficient was held constant for any particular test by holding the propeller speed constant while varying the angle of attack.

CORRECTIONS

Approximate corrections for jet-boundary effects were applied to the angle of attack by the methods of reference 5. Blockage corrections were determined and applied by the methods of reference 6. Strut-tare corrections were determined experimentally and applied to all data.

PRESENTATION OF RESULTS

The results of the investigation are presented in figures 5 to 8. The data of figure 5 are results of a calibration to determine the variation of thrust coefficient with propeller rotational speed for various blade angles. The effects of thrust coefficient on the variation of C_{Lq} and C_{mq} with C_L for the model having $(\beta_0)_F = 25^\circ$ are shown in figure 6. Also shown in figure 6 are the characteristics of the model with propellers off. Effects of propeller blade angle on the variation of C_{Lq} and C_{mq} with C_L are shown in figure 7 for thrust coefficients of 0, 0.2, and 0.4. The effects of various control deflection on the parameters for the model with $(\beta_0)_F = 25^\circ$ and $T_c' = 0, 0.2, \text{ and } 0.4$ are shown in figure 8. All moment data are referred to the system of stability axes with the origin at the projection of the 14-percent wing mean aerodynamic chord on the plane of symmetry.

CONCLUDING REMARKS

An experimental investigation has been made in the Langley stability tunnel at low speed to determine the pitching stability derivatives of a 1/9-scale powered model of the Convair XFY-1 vertically rising airplane. Effects of thrust coefficient, control deflection, and propeller blade angle were investigated for the complete model. The tests were made

through an angle-of-attack range from about -4° to 29° , and the thrust-coefficient range was from 0 to 0.7.

In order to expedite distribution of these data, no analysis of the data has been prepared for this paper.

Langley Aeronautical Laboratory,
National Advisory Committee for Aeronautics,
Langley Field, Va., July 13, 1953.

M. J. Queijo

M. J. Queijo

Aeronautical Research Scientist

Walter D. Wolhart

Walter D. Wolhart

Aeronautical Research Scientist

H. S. Fletcher /msf

H. S. Fletcher

Aeronautical Research Scientist

Approved:

Thomas A. Harris

Thomas A. Harris

Chief of Stability Research Division

BS

REFERENCES

1. Queijo, M. J., Wolhart, W. D., and Fletcher, H. S.: Wind-Tunnel Investigation at Low Speed of the Static Longitudinal and Lateral Stability Characteristics of a 1/9-Scale Powered Model of the Convair XFY-1 Vertically Rising Airplane - TED No. NACA DE 373. NACA RM SL53B20, Bur. Aero., 1953.
2. Queijo, M. J., Wolhart, W. D., and Fletcher, H. S.: Wind-Tunnel Investigation at Low Speed of the Yawing Stability Derivatives of a 1/9-Scale Powered Model of the Convair XFY-1 Vertically Rising Airplane - TED No. NACA DE 373. NACA RM SL53D01, Bur. Aero., 1953.
3. Queijo, M. J., Wolhart, Walter D., and Fletcher, H. S.: Wind-Tunnel Investigation at Low Speed of the Rolling Stability Derivatives of a 1/9-Scale Powered Model of the Convair XFY-1 Vertically Rising Airplane - TED No. NACA DE 373. NACA RM SL53E13, Bur. Aero., 1953.
4. Bird, John D., Jaquet, Byron M., and Cowan, John W.: Effect of Fuselage and Tail Surfaces on Low-Speed Yawing Characteristics of a Swept-Wing Model As Determined in Curved-Flow Test Section of the Langley Stability Tunnel. NACA TN 2483, 1951. (Supersedes NACA RM L8G13.)
5. Silverstein, Abe, and White, James A.: Wind-Tunnel Interference With Particular Reference to Off-Center Positions of the Wing and to the Downwash at the Tail. NACA Rep. 547, 1936.
6. Herriot, John C.: Blockage Corrections for Three-Dimensional-Flow Closed-Throat Wind Tunnels, With Consideration of the Effect of Compressibility. NACA Rep. 995, 1950. (Supersedes NACA RM A7B28.)

~~CONFIDENTIAL~~

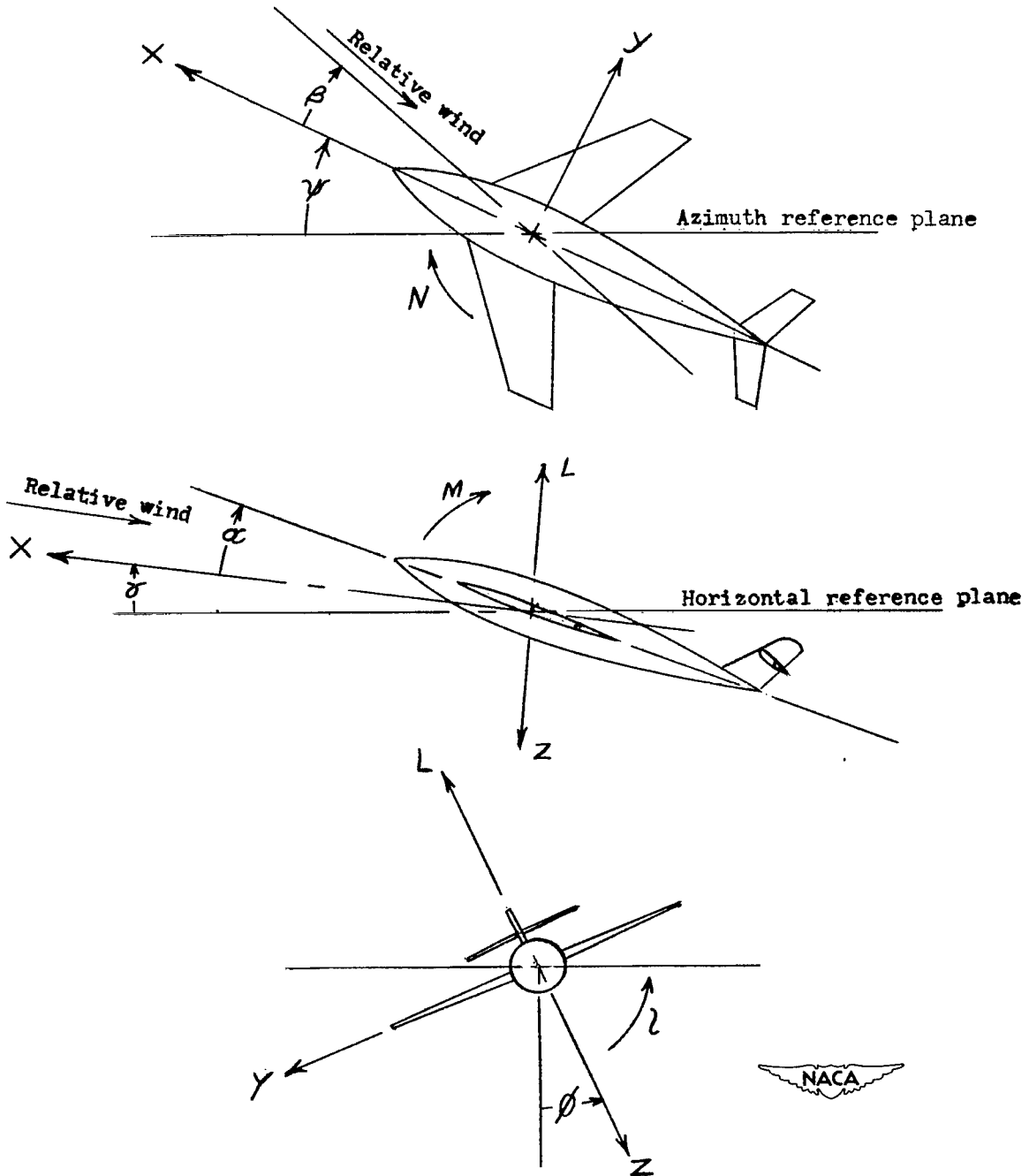

Figure 1.- System of stability axes. Arrows indicate positive direction of forces, moments, and displacements.

~~CONFIDENTIAL~~

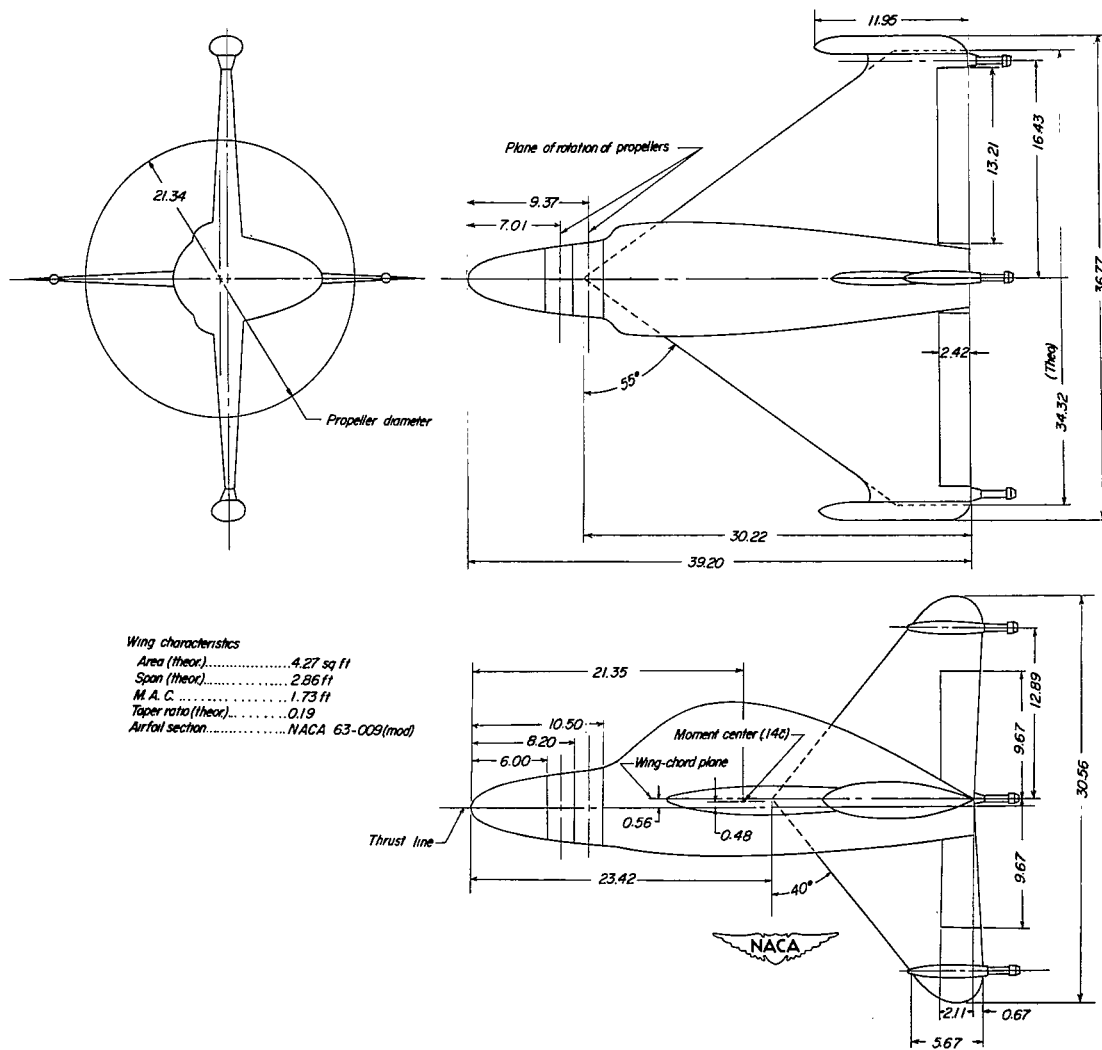

Figure 2.- Geometric characteristics of model. All dimensions are in inches.

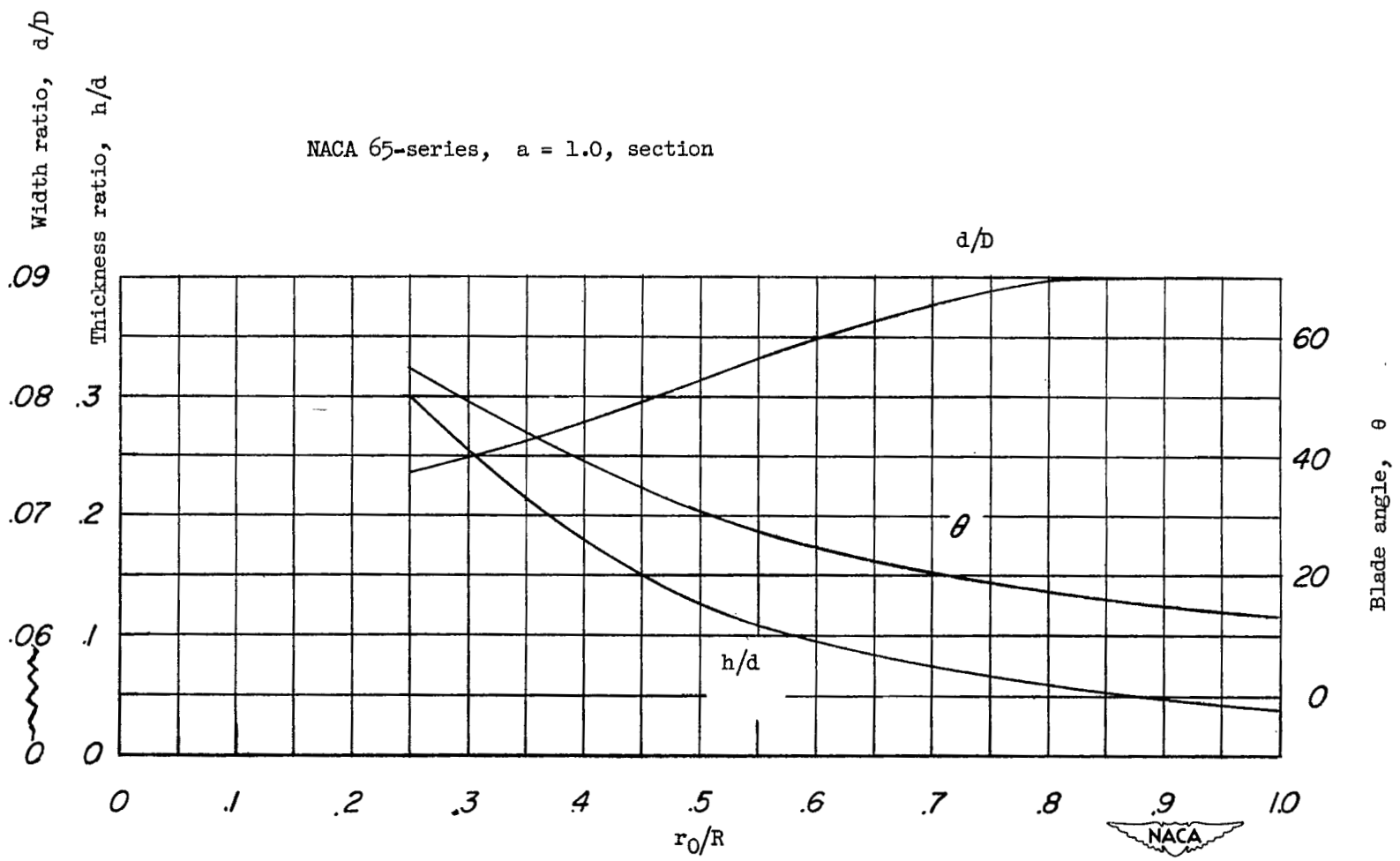
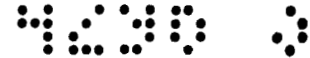
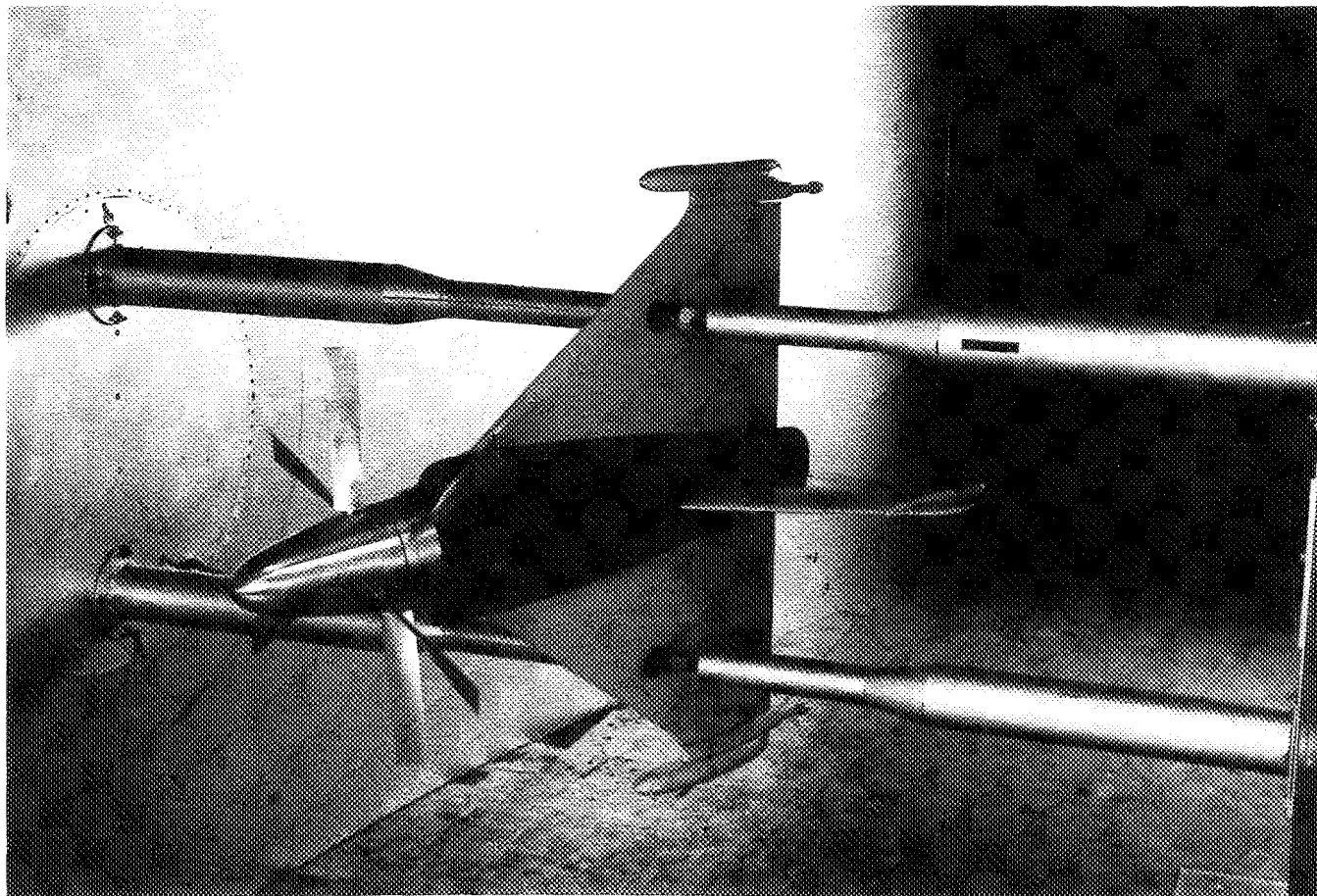

Figure 3.- Geometric characteristics of propeller blades used on a 1/9-scale model of the Convair XFY-1 vertically rising airplane. $R = 0.889$ foot.





L-77778

(a) Front view.

Figure 4.- Photographs of model mounted in the Langley stability tunnel for pitching flow tests, showing dummy struts and fairings used on tare tests.

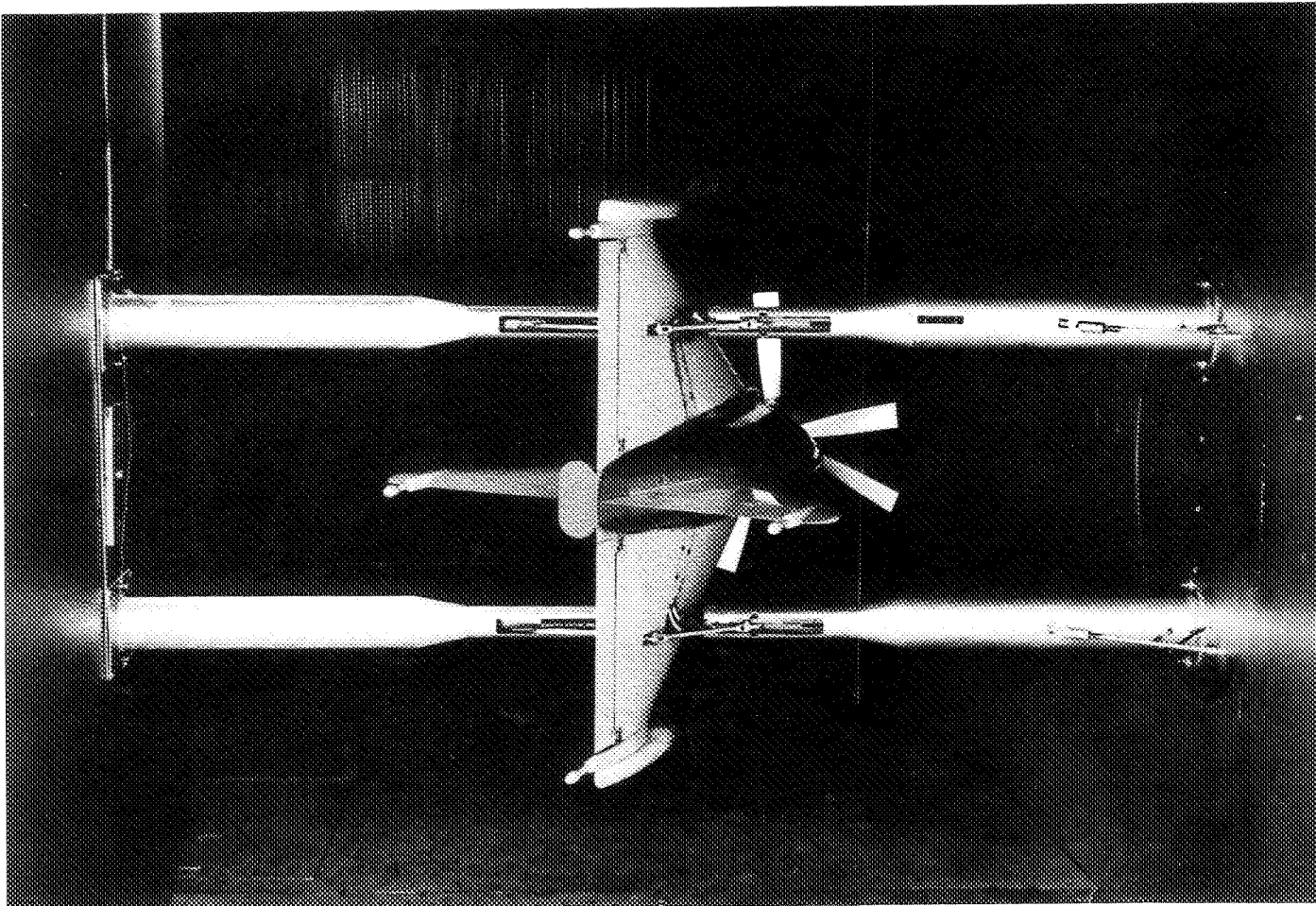

L-77779

(b) Rear view.

Figure 4.- Concluded.

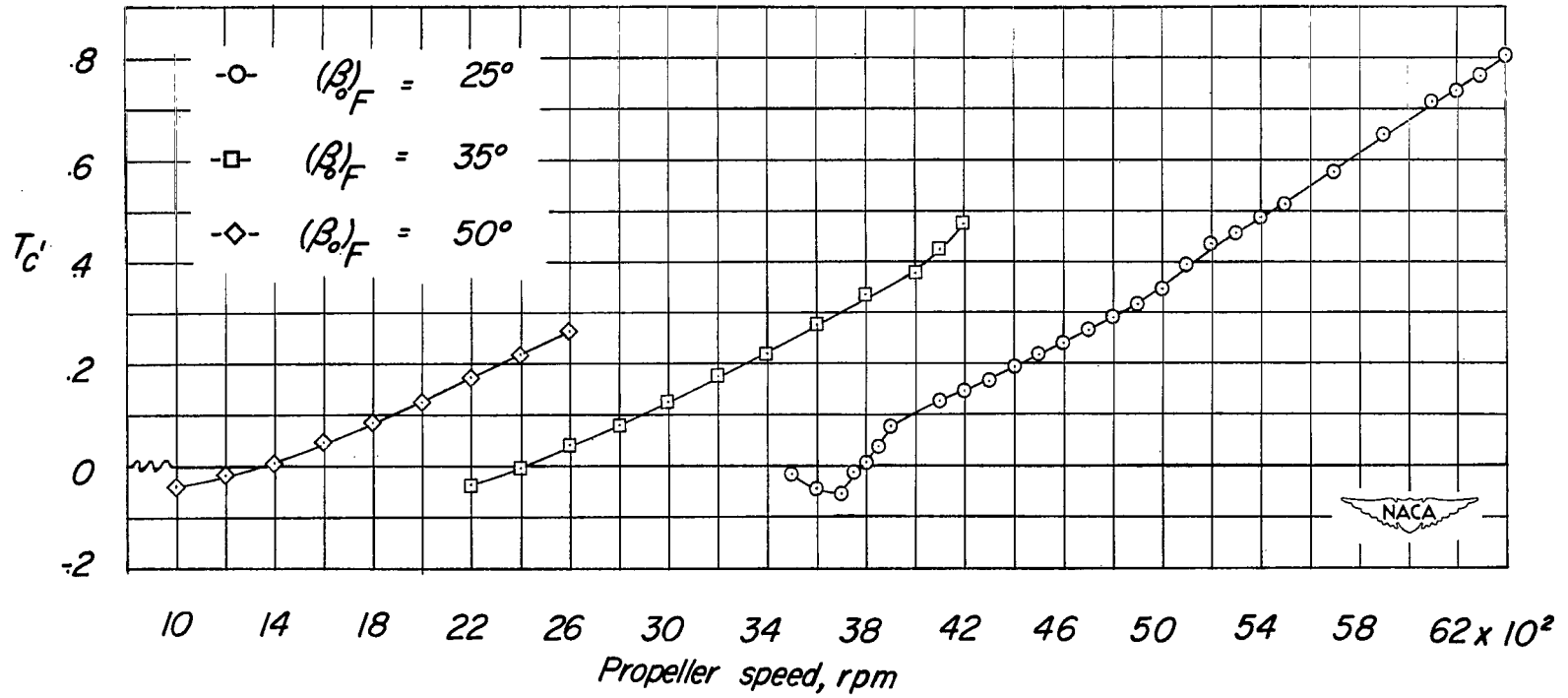
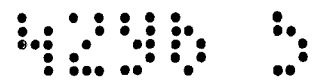

Figure 5.- Variation of thrust coefficient with propeller speed for various propeller-blade angles. $\alpha = 0^\circ$. $q = 16 \text{ lb/sq ft}$.



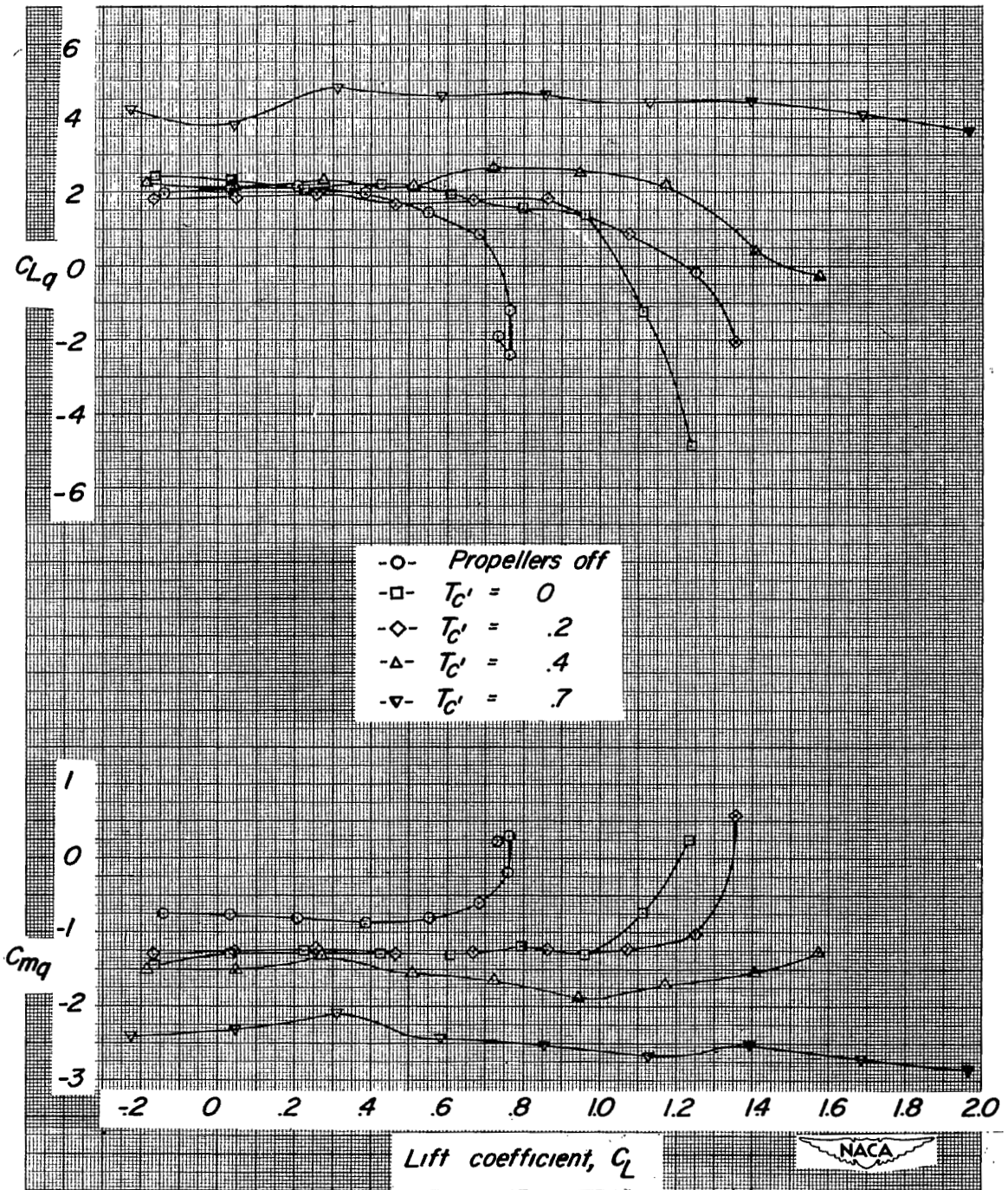
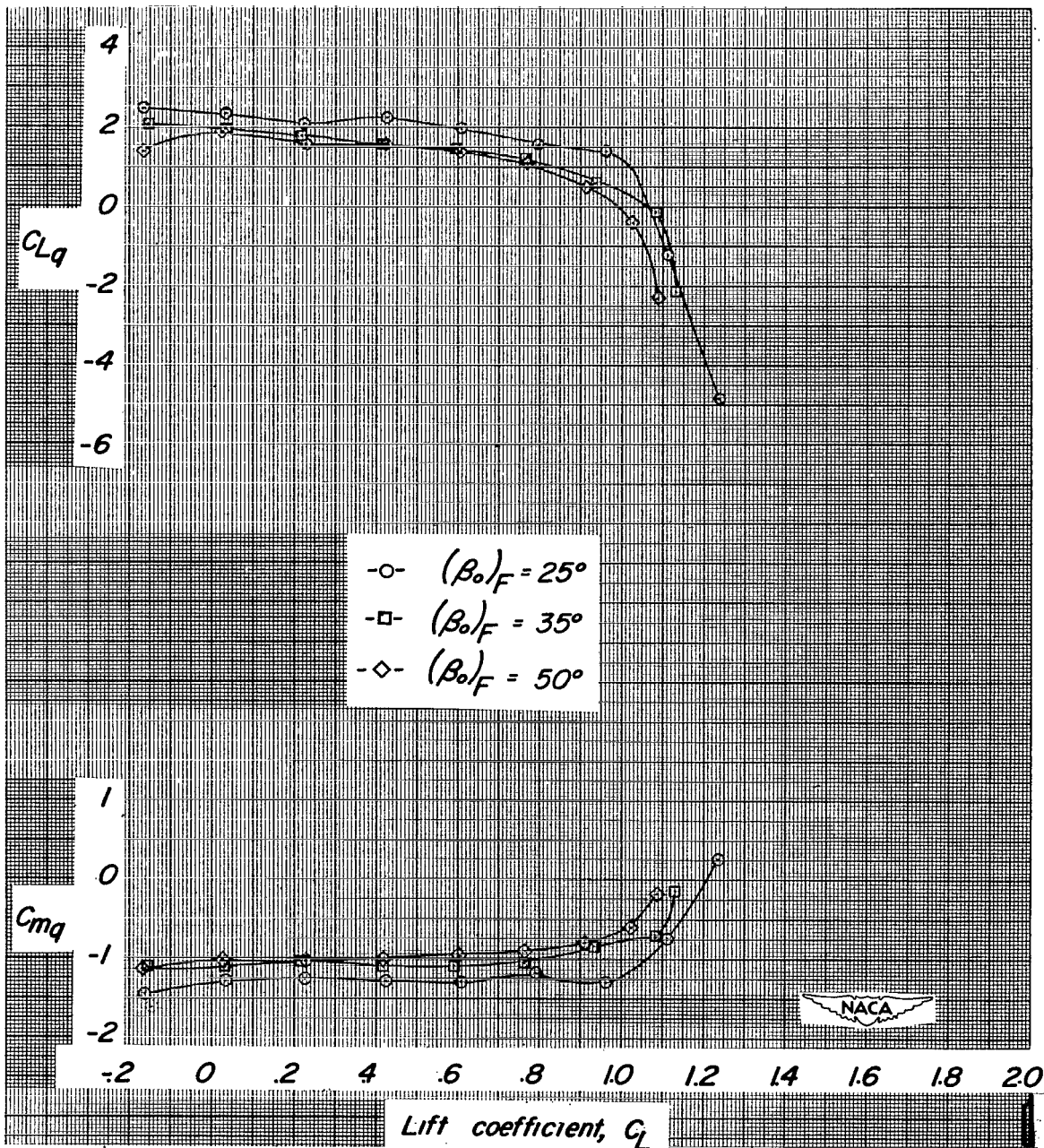

Figure 6.- Effect of thrust coefficient on the pitching stability derivatives of a 1/9-scale powered model of the Convair XFY-1 vertically rising airplane. $(\beta_0)_F = 25^\circ$.



(a) $T_c' = 0$.

Figure 7.- Effect of propeller blade angle on the pitching stability derivatives of a 1/9-scale powered model of the Convair XFY-1 vertically rising airplane.

~~CONFIDENTIAL~~

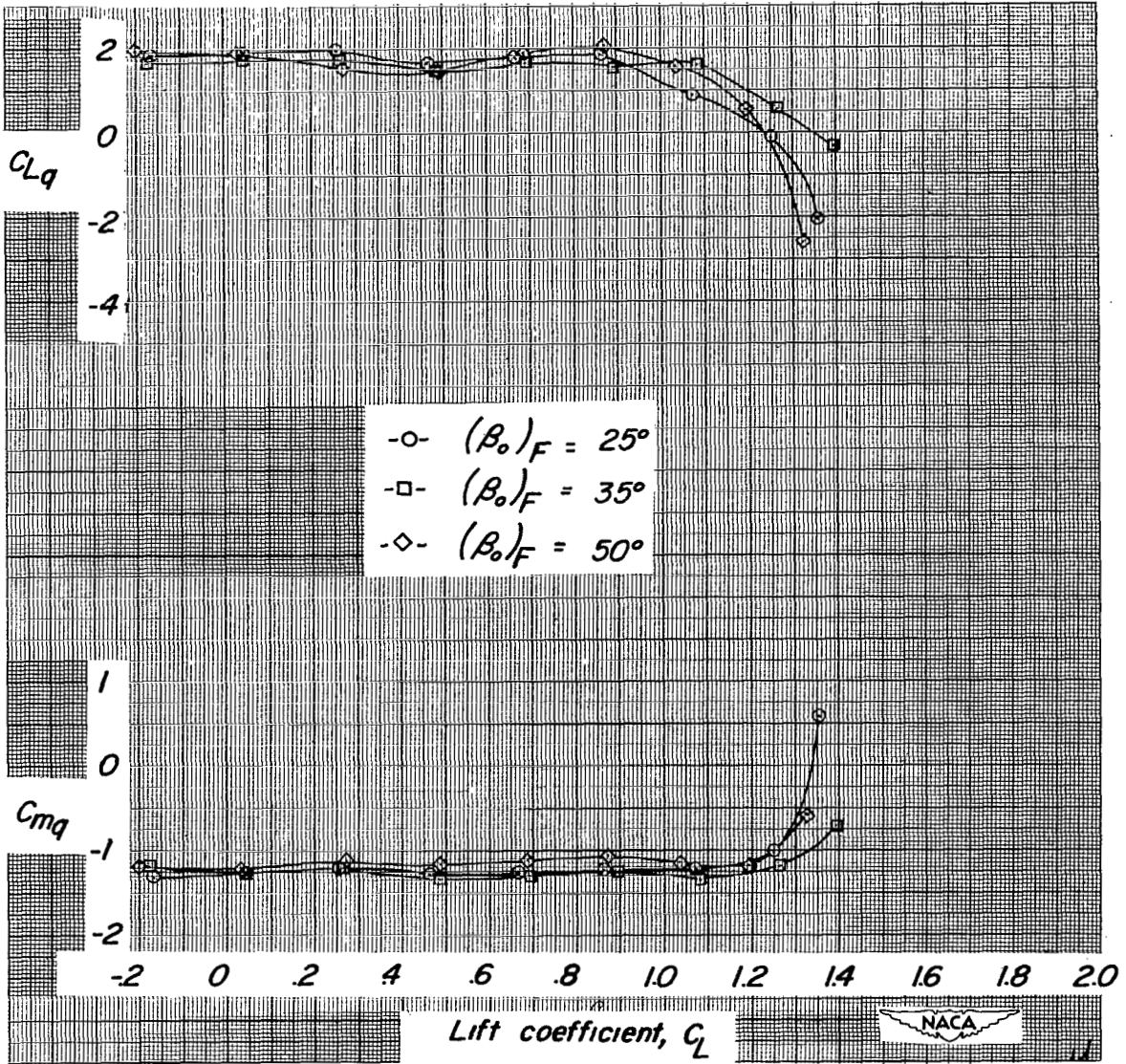

(b) $T_c' = 0.2$.

Figure 7.- Continued.

~~CONFIDENTIAL~~

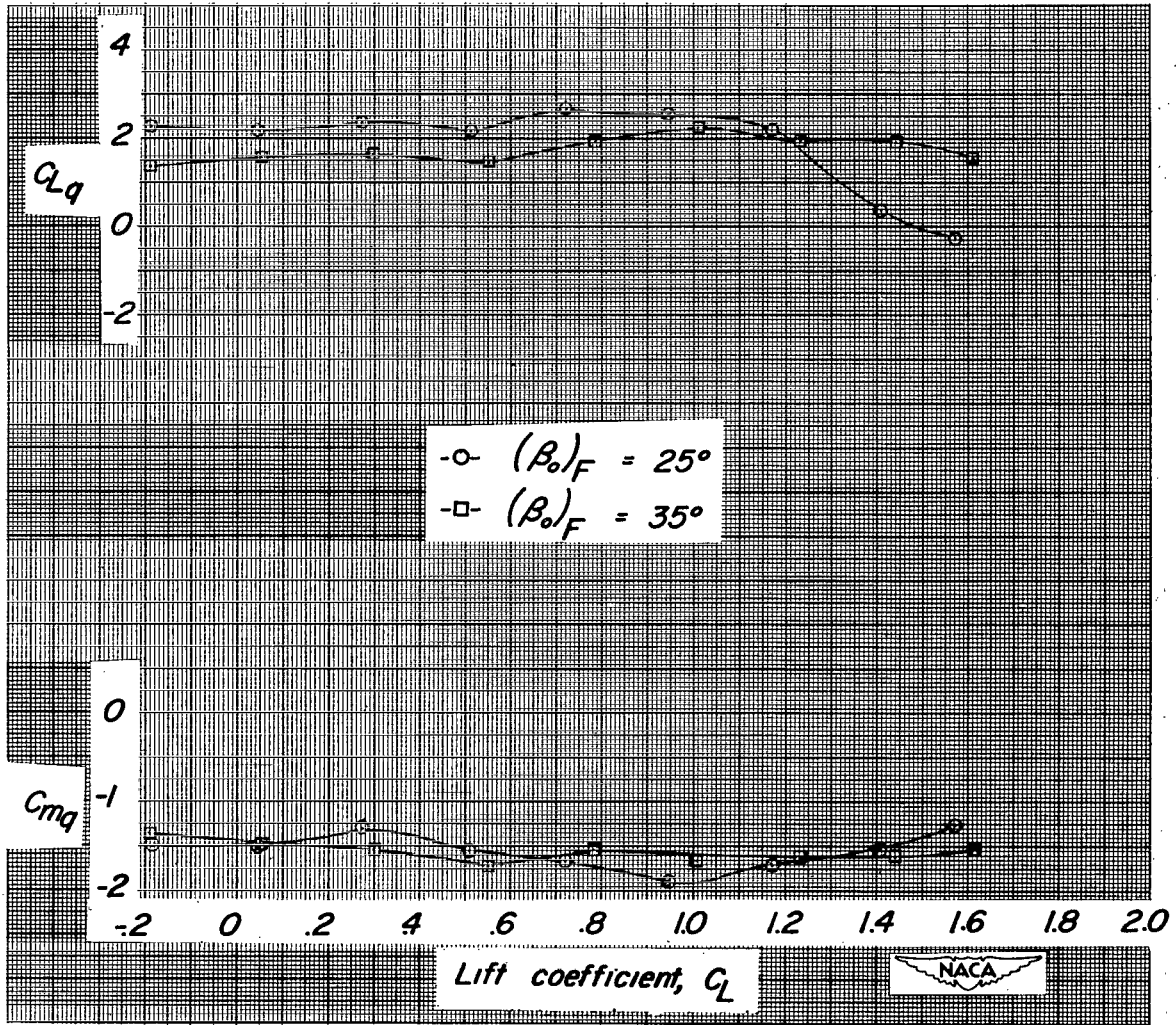

(c) $T_c' = 0.4$.

Figure 7.- Concluded.

~~CONFIDENTIAL~~

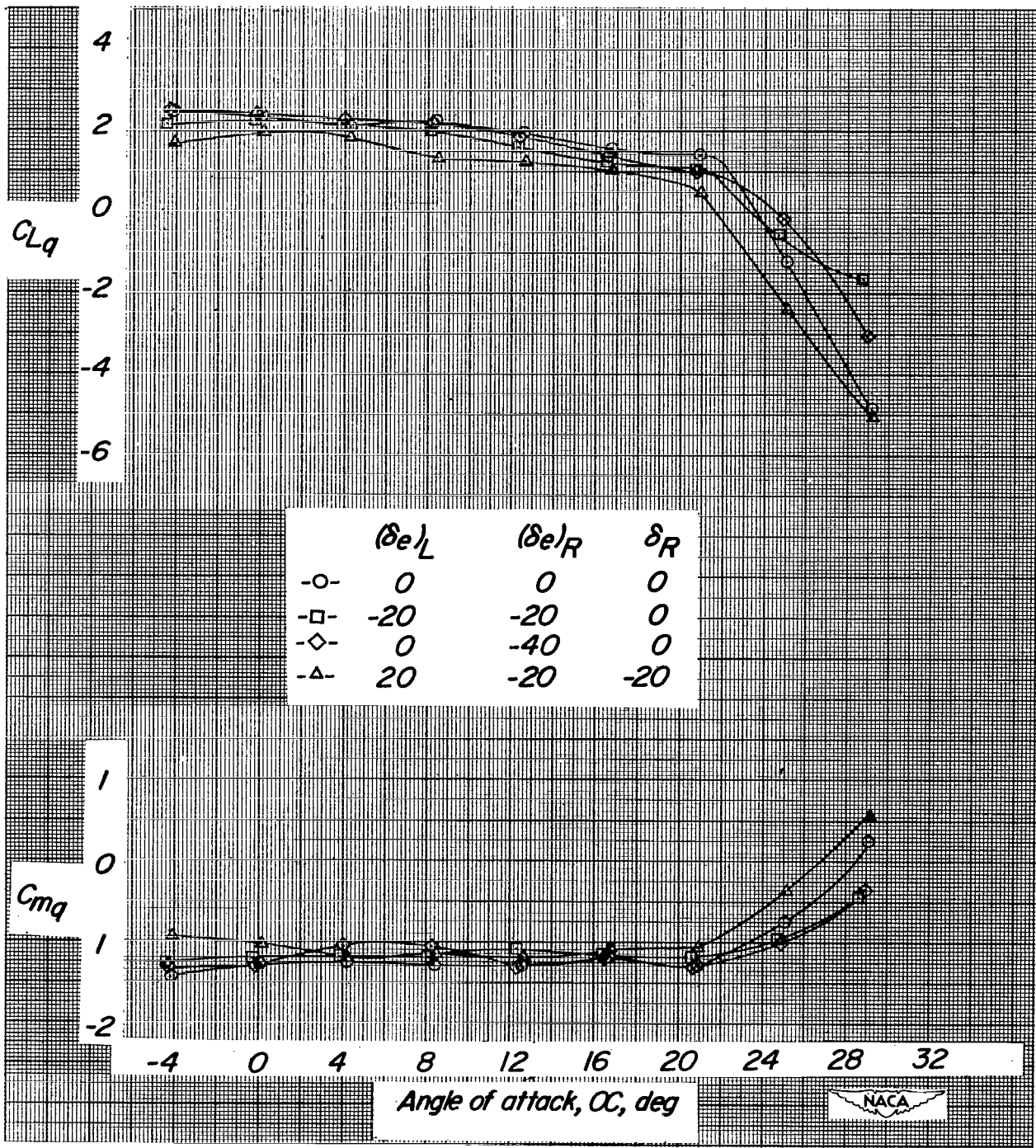

(a) $T_c' = 0$.

Figure 8.- Effect of control deflection on the pitching stability derivatives of a 1/9-scale powered model of the Convair XFY-1 vertically rising airplane. $(\beta_0)_F = 25^\circ$.

~~CONFIDENTIAL~~

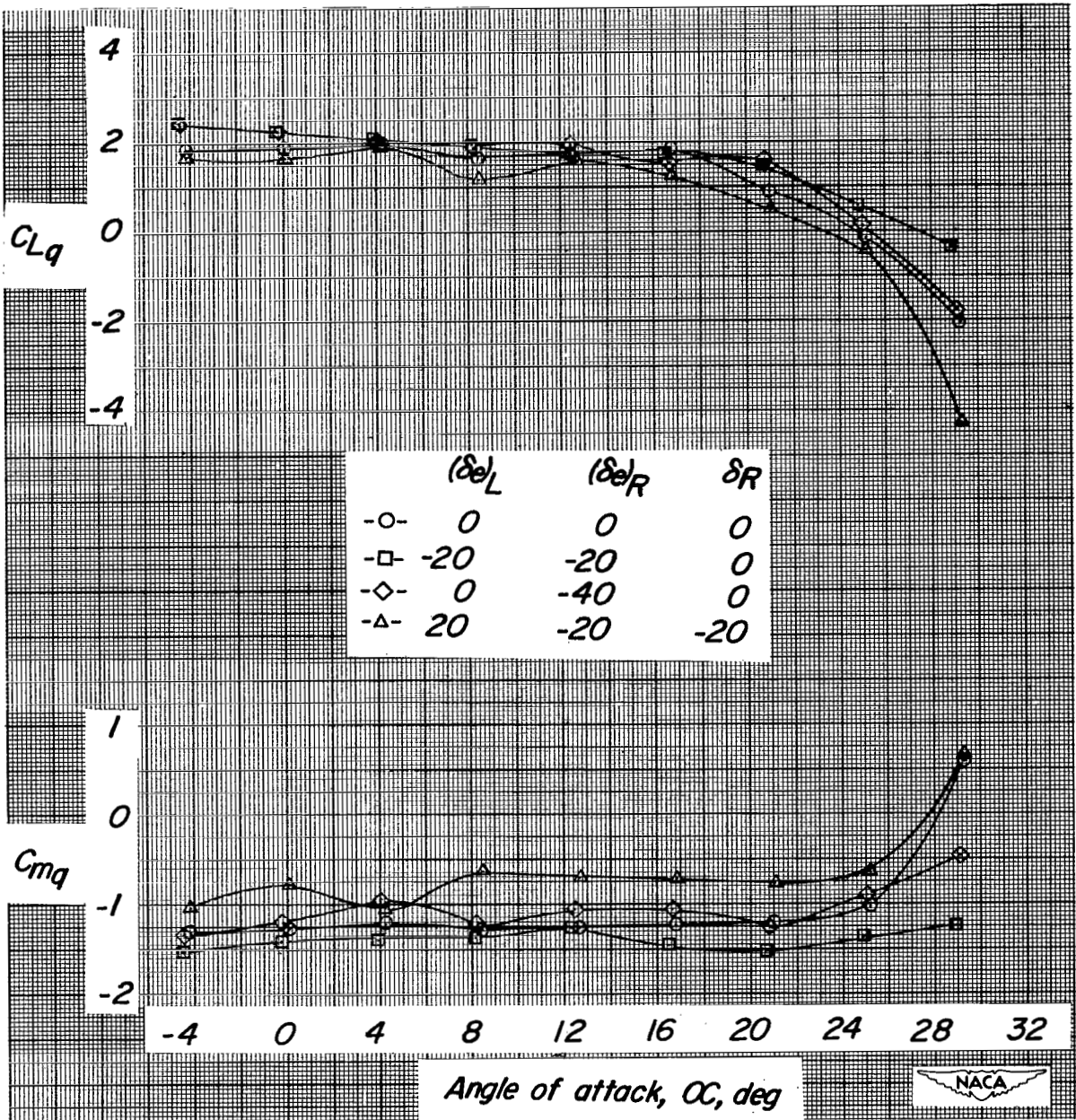

(b) $T_c' = 0.2$.

Figure 8.- Continued.

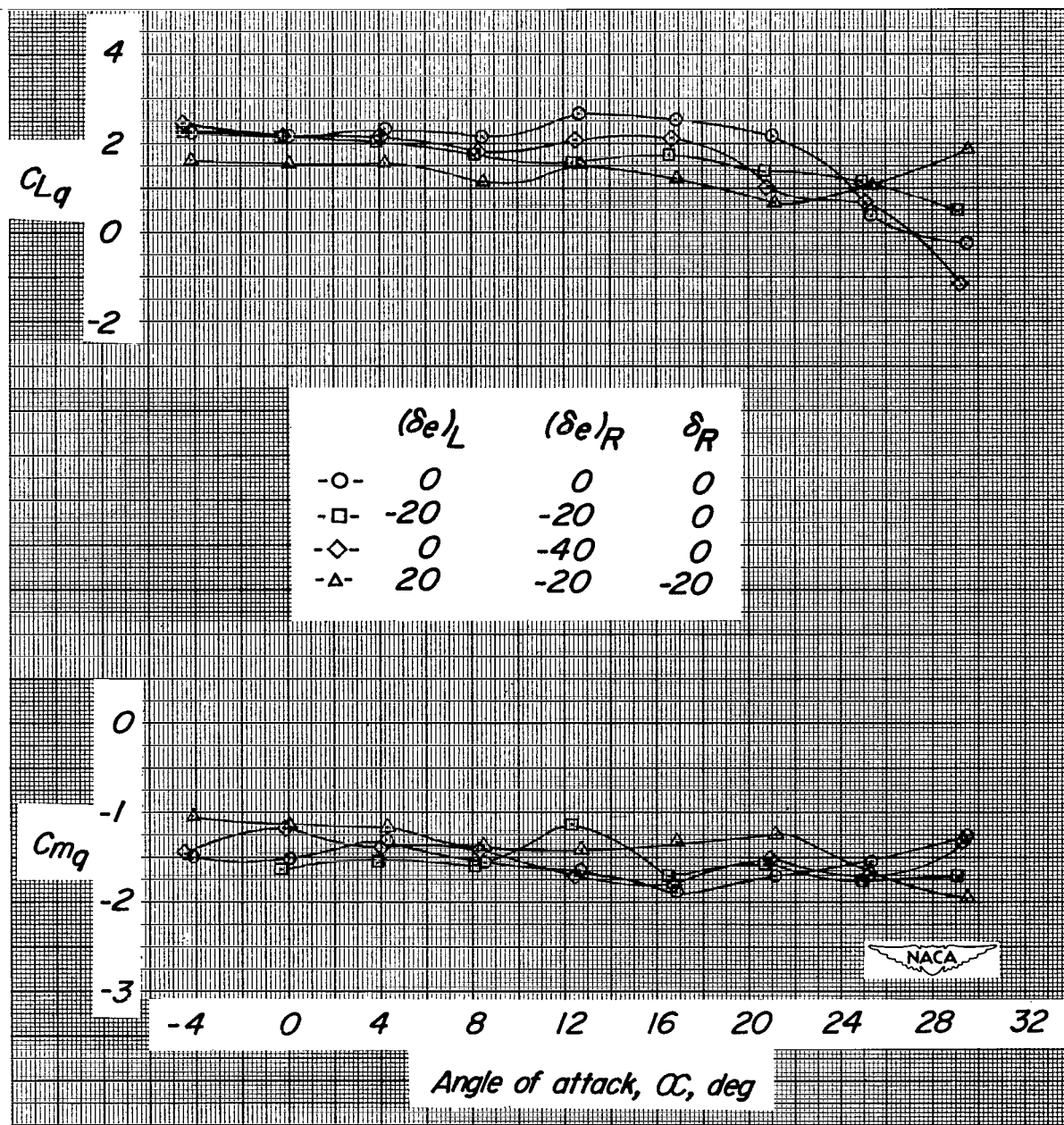

(c) $T_c' = 0.4$.

Figure 8.- Concluded.

SECURITY

NASA Technical Library

INFORMATION



3 1176 01438 6073

~~CONFIDENTIAL~~