

REC'D SEP 25 1946

CLASSIFICATION CANCELLED

RM No. SL6H28

CLASSIFICATION CANCELLED

PERMANENT FILE COPY

H. L. Dryden
Dir., Aeron. NACA
NACA
2-10-53
OES
NACA change #1371
Status: Inactive

NO 9,52
Fairchild
109-11

RESEARCH MEMORANDUM

for the

Bureau of Aeronautics, Navy Department

FREE-SPINNING-TUNNEL TESTS OF A 1/16-SCALE MODEL

OF THE FAIRCHILD XNQ-1 AIRPLANE

TED NO. NACA 2398

By

Lee T. Daughtridge, Jr.

Langley Memorial Aeronautical Laboratory
Langley Field, Va.

FILE COPY

To be returned to
the files of the National
Advisory Committee
for Aeronautics
Washington, D. C.

[REDACTED]

[REDACTED]

TECHNICAL
EDITING
WAIVED

**NATIONAL ADVISORY COMMITTEE
FOR AERONAUTICS**

WASHINGTON

SEP 30 1946

CLASSIFICATION CANCELLED

6

~~CLASSIFICATION~~ CANCELLED

NATIONAL ADVISORY COMMITTEE FOR AERONAUTICS

RESEARCH MEMORANDUM

for the

Bureau of Aeronautics, Navy Department

FREE-SPINNING TUNNEL TESTS OF A 1/18-SCALE MODEL

OF THE FAIRCHILD XNQ-1 AIRPLANE

TEST NO. NACA 2398

By Lee T. Daughtridge, Jr.

SUMMARY

Spin tests have been performed in the Langley 20-foot free-spinning tunnel on a 1/18-scale model of the Fairchild XNQ-1 airplane. The spin and recovery characteristics of the model were determined for the normal gross-weight loading and for two variations from this loading - center of gravity moved rearward and relative mass distribution increased along the fuselage. These tests were performed for two vertical-tail plan forms. The investigation also included simulated pilot-escape tests and rudder-force tests.

The recovery characteristics of the model were satisfactory for all conditions tested by full reversal of the rudder and by simultaneous neutralization of the rudder and elevator. It was indicated that if necessary to escape from the spinning airplane, the pilot should jump from the outboard side of the fuselage and as far rearward as possible. As determined from spin model tests, the rudder pedal force required to reverse the rudder for recovery from the spin will be light.

INTRODUCTION

In accordance with a request of the Bureau of Aeronautics, Navy Department, a 1/18-scale model of the Fairchild XNQ-1 airplane has been tested in the Langley 20-foot free-spinning tunnel.

~~CLASSIFICATION~~ CANCELLED

The XNQ-1 is a light training airplane with a two-place tandem seating arrangement and conventional landing gear.

All tests were performed with the model in the clean condition (landing gear retracted, flaps neutral, and canopy closed). The erect spin and recovery characteristics of the model were determined for the normal gross-weight loading and for two variations of this loading: (1) center of gravity moved rearward of normal and (2) relative mass distribution increased along the fuselage. Each of these loading conditions was investigated for different vertical tail plan forms (designated as original and alternate vertical tails by Fairchild). The recovery characteristics were generally determined by fully reversing the rudder. Dr. H. Serbin, a representative of the Fairchild Aircraft Company, witnessed some of the spin tests, and during his visit it was decided to also run tests in which rudder alone or rudder and elevator simultaneously were neutralized. The inverted spin and recovery characteristics were determined for the normal-loading condition with the original vertical tail installed. The rudder pedal force necessary to effect recovery from a spin was determined and tests simulating emergency pilot escape were also performed on the model.

SYMBOLS

b	wing span, feet
S	wing area, square feet
m	mass of airplane, slugs
c	wing chord
\bar{c}	mean aerodynamic chord, feet
x/\bar{c}	ratio of distance of center of gravity rearward of leading edge of mean aerodynamic chord to mean aerodynamic chord
z/\bar{c}	ratio of distance between center of gravity and thrust line to mean aerodynamic chord (positive when center of gravity is below thrust line)
I_x, I_y, I_z	moments of inertia about $X_z, Y,$ and Z - body axes respectively, slug-feet ²

$\frac{I_X - I_Y}{mb^2}$	inertia yawing-moment parameter
$\frac{I_Y - I_Z}{mb^2}$	inertia rolling-moment parameter
$\frac{I_Z - I_X}{mb^2}$	inertia pitching-moment parameter
ρ	air density, slug per cubic foot
μ	relative density of airplane ($m/\rho S b$)
α	angle between thrust line and vertical (approximately equal to absolute value of angle of attack at plane of symmetry), degrees
ϕ	angle between span axis and horizontal, degrees
V	full-scale true rate of descent, feet per second
Ω	full-scale angular velocity about spin axis, revolutions per second
σ	helix angle, angle between flight path and vertical, degrees (For this model, the average absolute value of the helix angle was approximately 7° .)
β	approximate angle of sideslip at center of gravity, degrees (Sideslip is inward when inner wing is down by an amount greater than the helix angle.)

APPARATUS AND METHODS

Model

The 1/18-scale model of the XNQ-1 airplane used in the spin tests was furnished by the contractor and was checked for dimensional accuracy and prepared for testing by Langley. The vertical position of the horizontal tail was found in error and was corrected by Langley. A three-view drawing and photographic views of the model with the original vertical tail installed are shown in figures 1 and 2, respectively. A drawing comparing the original and alternate vertical-tail plan forms is presented as figure 3.

The dimensional characteristics of the XNQ-1 airplane are presented in table I.

The model was ballasted to obtain dynamic similarity to the airplane at an altitude of 10,000 feet ($\rho = 0.001756$ slug/cu. ft). An electromagnetic remote-control mechanism was installed in the model to actuate the controls for the recovery attempts and to release the dummy pilot for the pilot-escape tests. Sufficient moments were exerted on the controls during the recovery attempts to reverse them fully and rapidly.

The dummy pilot used in the pilot-escape tests was constructed by Langley and scaled down in both dimensions and weight to represent an average pilot with a parachute pack (200 lb) at 10,000 feet altitude.

Wind Tunnel and Testing Technique

The tests were performed in the Langley 20-foot free-spinning tunnel, the operation of which is, in general, similar to that described in reference 1 for the Langley 15-foot free-spinning tunnel except that the model launching technique has been changed. With the controls set in the desired position, the model is launched by hand with rotation into the vertically rising air stream. After a number of turns in the established spin (fig. 4 shows the model spinning in the Langley 20-foot free-spinning tunnel), recovery attempt is made by moving one or more controls by means of the remote-control mechanism. After recovery, the model dives into a safety net. The spin data obtained from these tests are then converted from model values to corresponding full-scale values by methods also described in reference 1.

In accordance with standard spin-tunnel procedure, tests were performed to determine the spin and recovery characteristics of the model for the normal-spinning control configuration (elevator full up, ailerons neutral, and rudder full with the spin) and for various other aileron and elevator combinations including neutral and maximum settings of the surfaces for the various model loadings and configurations. Recovery was generally attempted by rapid reversal of the rudder from full with to full against the spin, although, as previously mentioned, some recovery attempts were made by neutralization of the rudder alone and by simultaneous neutralization of the rudder and elevator. Tests were also performed to evaluate the possible adverse effects on recovery of small deviations from the normal control configuration for spinning. For these tests, the elevator was set either at its full-up deflection or at two-thirds of its full-up deflection and the ailerons were

set one-third of the full deflection in the direction conducive to slower recoveries. Recovery was attempted by rapidly reversing the rudder from full with to only two-thirds against the spin. This particular control configuration and manipulation is referred to herein as the "criterion spin." Turns for recovery are measured from the time the controls are moved to the time the spin rotation ceases. The criterion for a satisfactory recovery from a spin for a spin-tunnel model has been adopted as 2 turns or less, based primarily on the loss of altitude of the corresponding airplane during the recovery and subsequent dive. Recovery characteristics of a model are considered satisfactory, however, if recovery attempted from the criterion spin requires no more than $2\frac{1}{4}$ turns.

For recovery attempts in which the model struck the safety net before recovery could be effected, the number of turns from the time the controls were moved to the time the model struck the safety net was recorded. This number indicates that the model required more turns to recover from the spin than shown, as, for example, $> 2\frac{1}{2}$. A $> 2\frac{1}{2}$ -turn recovery, however, does not necessarily indicate an improvement when compared to a > 4 -turn recovery.

For the pilot-escape tests, the dummy pilot was alternately attached to the side of the fuselage at the forward seat and at the rearward seat in order to simulate either the pilot or the student jumping from the airplane. The dummy was released from the inboard side (the right side in a right spin) and from the outboard side of the fuselage during a flat spin and a typical steep spin. No flat spins were actually obtained during the model spin tests, but a flat spin was simulated for the pilot-escape tests by releasing the dummy while the model was still in the flat attitude caused by the rotational energy imparted to the model during launching.

In performing the rudder pedal force tests, only the force necessary to move the rudder so as to effect a normal recovery from the spin was determined. To accomplish this, the tension in the rubber band that pulls the rudder against the spin was adjusted to represent known hinge-moment values about the rudder hinge line. A series of recovery tests was then made, the tension in the rubber band being systematically lowered, until the turns for recovery began to increase. The value of the model hinge moment at this point was then converted to the corresponding full-scale rudder pedal force at the equivalent altitude at which the tests were made.

PRECISION

The spin data presented are believed to be the true values given by the model within the following limits:

α , degrees	± 1
ϕ , degrees	± 1
V, percent	± 5
Ω , percent	± 3

Turns for recovery	}	$+\frac{1}{4}$ turn when obtained from motion-picture record
		$+\frac{1}{2}$ turn when obtained from visual estimate

In some instances in which it was difficult to test the model due to the oscillatory or wandering nature of the spin, the foregoing limits may have been exceeded.

Comparison between spin results of models and corresponding airplanes (references 1 and 2) indicates that spin-tunnel results are not always in complete agreement with airplane spin results. In general, the models spun at a somewhat smaller angle of attack, with a slightly higher rate of descent, and with 5° to 10° more outward sideslip than did the corresponding airplanes. The comparison made in reference 2 for 20 models shows that 80 percent of the model recovery tests predicted satisfactorily the number of turns required for recovery from the spin of the corresponding airplane and that 10 percent were optimistic and 10 percent were pessimistic as regards the airplane recovery characteristics.

Little can be stated about the precision of the pilot-escape tests as no comparable full-scale data are available. It is considered, however, that when the dummy pilot is observed to clear all parts of the model by a large margin after being released, the pilot may safely escape from the spinning airplane in an emergency.

Because of the impracticability of ballasting the model exactly and because of inadvertent damage to the model during the spin tests, the mass distribution of the model varied from the true scaled-down values within the following limits:

Weight, percent	4 high to 7 high	
Center-of-gravity location, percent \bar{c}	0 to 1 rearward	
Moments of inertia {	I_X , percent	6 high to 7 high
	I_Y , percent	2 low to 1 low
	I_Z , percent	2 high to 6 high

The measurement of the mass characteristics were made within the following limits of accuracy:

Weight, percent	±1
Center-of-gravity location, percent \bar{c}	±1
Moments of inertia, percent	±5

The controls were set with an accuracy of $\pm 1^\circ$.

TEST CONDITIONS

Spin tests were performed for the conditions of the model listed in table II. Reference 5 indicates that moving the center of gravity rearward generally has an adverse effect on the spin and recovery characteristics of models with relatively low values of the relative density parameter μ . The XNQ-1 model, therefore, was tested with the center of gravity moved rearward in order to determine the effect. The model was tested with the relative mass distribution increased along the fuselage to determine if the effect of control disposition and manipulation on the spin and recovery characteristics would be changed. According to reference 4, an increase in relative mass distribution along the fuselage should tend to reverse the effect of the ailerons and elevators.

Values of the tail-damping power factor for the original and the alternate vertical tails are given in table I. The tail-damping power factor was computed according to the method given in reference 3. The values presented were computed for the normal gross-weight center-of-gravity location. A comparison of the values of the mass characteristics and inertia parameter for the loadings tested on the model, converted to corresponding full-scale values, and for various loadings possible on the airplane is presented in table III. The inertia parameters are also plotted on figure 5. This figure can be used in predicting the relative effect of controls on spin and recovery characteristics as shown in reference 4.

The maximum control deflections used in the tests were as follows:

Rudder, degrees	30 right, 30 left
Elevator, degrees	30 up, 20 down
Ailerons, degrees	24 up, 12 down

The partial control deflections used for the criterion spin were as follows:

Rudder, $\frac{2}{3}$ deflected, degrees	20
Elevator, deflected $\frac{2}{3}$ up, degrees	20
Ailerons, $\frac{1}{3}$ deflected, degrees	8 up, 4 down

When the center of gravity was moved rearward on the model, the moments of inertia were kept constant about the original center of gravity. When the relative mass distribution was increased along the fuselage, the center of gravity was kept at its original position.

RESULTS AND DISCUSSION

The results of the spin tests are presented in charts 1 to 5. Results for right and left spins were similar, and the results are arbitrarily presented in terms of equivalent right spins.

Original Vertical Tail

Normal gross-weight loading.- The results of spin tests of the model in the normal gross-weight loading (point 1 in table III and fig. 5) with the original vertical tail are presented in chart 1. The spins obtained were steep (angle of attack about 25°) and were generally oscillatory in pitch and roll. The recoveries from these spins by full rudder reversal were very rapid, the slowest recovery requiring only 1 turn. When the elevator was up and the ailerons were against the spin, the model recovered so rapidly that it immediately began to spin in the opposite direction before striking the safety net. It appears, therefore, that care must be exercised to avoid entering a spin in the opposite direction when attempting a recovery in the airplane. The model would not spin with the elevator neutral or full down when the ailerons were neutral or against the spin.

Inverted spin tests were also performed on the model in the normal gross-weight loading with the original vertical-tail plan form. The results of these tests are presented in chart 2. The method of plotting the data for inverted spins is different than that for erect spins. For fully developed inverted spins, "controls crossed" (right rudder pedal forward and stick to left for spins to pilot's right) is plotted at the right of the chart, and "stick back" is

plotted at the bottom of the chart. When the controls are crossed in the fully developed spin, the ailerons aid the rolling motion, and when the controls are together, the ailerons oppose the rolling motion. The angle of wing tilt ϕ is given as up or down relative to the ground.

For the inverted spin tests, the model would not spin for any control configuration tested except with the stick full forward and one-third or more to the left (right rudder pedal) and stick neutral longitudinally and full left. Recoveries were effected very rapidly by rudder reversal from the spins that were obtained.

Variations from the normal gross-weight loading.- The results of tests of the model with the center of gravity moved 10 percent of the mean aerodynamic chord rearward of normal (point 2 in table III and fig. 5) and for tests with I_y and I_z increased 20 percent of I_y (point 3 in table III and fig. 5) are presented in chart 3.

Moving the center of gravity rearward of normal produced only a slight adverse effect on the spin and recovery characteristics. The number of turns necessary for recovery from the normal and the criterion spins increased slightly, and the model spun with the stick neutral laterally and longitudinally where it would not spin for this control configuration when the center of gravity was in the normal position.

When the relative mass distribution was increased along the fuselage, spins were obtained for all control configurations tested. The recoveries from all these spins, however, were still very rapid.

From the foregoing results, it appears that the small range of center-of-gravity movement rearward of normal (approximately 2 percent of the mean aerodynamic chord) and the small changes in the relative mass distribution from the normal possible on the airplane will not appreciably affect the full-scale recovery characteristics. Inasmuch as the model sometimes went into a spin in the opposite direction immediately after recovery, it appears that the pilot should exercise care to avoid such an occurrence on the airplane.

Alternate Vertical Tail

Normal gross-weight loading.- The results of tests of the model in the normal gross-weight loading with the alternate vertical tail installed are presented in chart 4. The spin characteristics and the

recovery characteristics by rudder reversal were similar to those obtained with the original tail, the spins with the alternate tail being slightly steeper than those with the original tail. According to the criterion of reference 3, it would be expected that the results with the alternate tail would be inferior to those with the original tail, inasmuch as the tail-damping power factor is lower. The rudder of the alternate tail is smaller, however, and probably produces less pro-spin yawing moment when with the spin than does the rudder of the original tail. This probably accounts for the steeper spin, and thus less anti-spin yawing moment is required of the rudder for recovery.

Neutralizing the rudder alone was not sufficient to effect satisfactory recoveries, but neutralizing the rudder and elevator simultaneously produced recoveries almost as rapid as those obtained by reversing the rudder alone.

No inverted spin tests were performed with the alternate vertical tail, but it is believed that the results obtained for the original tail are applicable.

Variations from the normal gross-weight loading.- The results of tests of the model with the center of gravity moved 10 percent of the mean aerodynamic chord rearward of normal and of tests with I_y and I_z increased 20 percent of I_y are presented in chart 5.

With the center of gravity moved rearward, the spins were steep, and although not tested, recoveries attempted by full rudder reversal would undoubtedly have been rapid. Recoveries by rudder neutralization alone were unsatisfactory, but recoveries by simultaneous neutralization of the rudder and elevator were very rapid.

The spin characteristics with the relative mass distribution increased along the fuselage were very similar to those with the center of gravity moved rearward. Recovery by rudder neutralization alone was satisfactory for the normal-spinning configuration, but from results of tests in the normal loading it is felt that unsatisfactory recoveries may be obtained if the ailerons are deflected even slightly with the spin. Recoveries by simultaneous rudder and elevator neutralization were rapid for all aileron deflections.

From the results of the model tests, it appears that either reversing the rudder fully, being careful not to enter a spin in the opposite direction, or neutralizing the rudder and elevator simultaneously will cause the airplane to recover satisfactorily from developed spins.

Landing Condition

Current Navy specifications require only 1-turn spins to be demonstrated in the landing condition. The XNQ-1 model, therefore, was not tested in the landing condition inasmuch as experience indicates that an airplane will still be in an incipient spin after only 1 turn and that recoveries can be effected rapidly from this incipient spin. Nevertheless, if a spin is entered inadvertently in the landing condition, it is recommended that the flaps be retracted and that recovery be attempted immediately after entering the spin.

Pilot-Escape Tests

Tests were made to determine from which side of the fuselage and from which cockpit, front or rear, escape should be attempted if in an uncontrollable spin. It was observed that when the dummy was released at either cockpit location from the inboard side (right side in a right spin) of the fuselage, it went through the propeller disc for the steep spin and came dangerously close to the propeller disc for the flat spin. When the dummy was released from the outboard side of the fuselage from either cockpit, steep or flat spin, it cleared the model by going over the trailing edge of the outboard wing and under the tail. It was observed, however, than when released from the rearward cockpit, the dummy cleared the model by a larger margin. Therefore, if it becomes necessary for either occupant to abandon the spinning airplane, it is recommended that he jump from the outboard side and as far rearward as possible.

Rudder-Control Force

The discussion of the results of the spin tests has been based on control effectiveness alone without regard to the forces required to move the controls. As previously mentioned, however, an indication of the control force required was determined by measuring the minimum force necessary to move the rudder sufficiently to effect a normal recovery in the normal gross-weight loading with the original vertical tail. The force measured was 100 pounds full scale which is well within the capabilities of the pilot, and no difficulties should be encountered in reversing the rudder of this airplane for recovery from a spin.

CONCLUSIONS AND RECOMMENDATIONS

Based on the results of spin tests of 1/18-scale model of the XNQ-1 airplane in the clean condition, the following conclusions and recommendations are made regarding the spin and recovery characteristics of the airplane with either vertical tail at an altitude of 10,000 feet.

1. In the normal gross-weight loading, the spins will be steep and slightly oscillatory. Recovery for all control configurations will be rapid by rudder reversal or by neutralization of both rudder and elevator; changes in loading possible on the airplane will have no appreciable effect on the spin and recovery characteristics.
2. Recovery from inverted spins will be rapid by full rudder reversal, and recovery should be followed by neutralization of the stick, longitudinally and laterally.
3. If for any reason it becomes necessary to abandon the spinning airplane, it is recommended that the pilot jump from the outboard side of the fuselage and as far rearward as possible.
4. The rudder pedal force necessary to effect spin recovery will be light.

Langley Memorial Aeronautical Laboratory
National Advisory Committee for Aeronautics
Langley Field, Va.

Lee T. Daughtridge, Jr.
Lee T. Daughtridge, Jr.
Aeronautical Engineer

Approved:

Joseph A. Shortal
for Hartley A. Soule
Chief of Stability Research Division

CJB

REFERENCES

1. Zimmerman, C. H.: Preliminary Tests in the N.A.C.A. Free-Spinning Wind Tunnel. NACA Rep. No. 557, 1936.
2. Seidman, Oscar, and Neihouse, A. I.: Comparison of Free-Spinning Wind-Tunnel Results with Corresponding Full-Scale Spin Results. NACA MR, Dec. 7, 1938.
3. Seidman, Oscar, and Neihouse, A. I.: Free-Spinning Wind-Tunnel Tests of a Low-Wing Monoplane with Systematic Changes in Wings and Tails. IV.- Effect of Center-of-Gravity Location. NACA Rep. No. 672, 1939.
4. Neihouse, A. I.: A Mass-Distribution Criterion for Predicting the Effect of Control Manipulation on the Recovery from a Spin. NACA ARR. Aug. 1942.
5. Neihouse, Anshal I., Lichtenstein, Jacob H., and Pepoon, Philip W.: Tail-Design Requirements for Satisfactory Spin Recovery. NACA TN No. 1045, April 1946.

TABLE I.- DIMENSIONAL CHARACTERISTICS OF THE FAIRCHILD
XNQ-1 AIRPLANE

Over-all length, ft:	
Original vertical tail	27.69
Alternate vertical tail	26.70
Propeller diameter, ft	8.50
Propeller, no. of blades	2
Wing:	
Span, ft	41.6
Area, sq ft	236.00
Aspect ratio	7.4
Chord, in.:	
Root	89.9
Mean aerodynamic chord	70.7
Tip (design)	47.0
Taper ratio (design tip chord/root chord)	0.52
Location of mean aerodynamic chord, in.	
Leading edge of \bar{c} rearward of leading edge of root chord	4.8
Leading edge of \bar{c} below center line of fuselage	10.9
Angle of incidence, deg:	
Root	3.00
Mean aerodynamic chord	1.21
Tip	-1.00
Angle of geometric dihedral (in wing reference plan), deg	5
Angle of sweepback (at leading edge of wing) deg	2.50
Airfoil section:	
Root	NACA 2416
Tip	NACA 4409
Ailerons:	
Area (both ailerons), sq ft:	
Total	10.45
Rearward of hinge line	7.97
Span (at hinge line), in.	108.0
Chord, percent of wing chord (constant)	24.5

TABLE I.- DIMENSIONAL CHARACTERISTICS -Concluded

Horizontal tail surfaces:

Area, sq ft	
Total	47.38
Elevator	
Total	20.08
Rearward of hingeline	17.02
Span, ft	13.17
Distance from normal gross-weight center of gravity to elevator hinge line, in.	196

Vertical tail surfaces:

Area, sq ft	
Total	
Original	24.11
Alternate	20.97
Rudder	
Total	
Original	18.27
Alternate	12.50
Rearward of hinge line	
Original	16.47
Alternate	10.57
Span, ft	
Original	6.59
Alternate	6.06
Distance from normal gross-weight center of gravity to rudder hinge line (both), in.	209.7

Tail-damping-power factor:

With original vertical tail	488×10^{-6}
With alternate vertical tail	330×10^{-6}

TABLE II.-CONDITIONS OF THE FAIRCHILD XNQ-1 MODEL INVESTIGATED IN THE
FREE-SPINNING TUNNEL

[Clean condition (flaps neutral, landing gear retracted, canopy closed);
spins to pilot's right]

Variations from the normal gross-weight loading	Type of spin	Vertical tail	Data on chart
a None	Erect	Original	1
None	Inverted	Original	2
Center of gravity moved rearward 10 percent of \bar{c}	Erect	Original	3
I_y and I_z increased 20 percent of I_y	Erect	Original	3
b None	Erect	Alternate	4
Center of gravity moved rearward 10 percent of \bar{c}	Erect	Alternate	5
I_y and I_z increased 20 percent of I_y	Erect	Alternate	5

^aRudder-tension tests were performed for this condition.

^bPilot-escape tests were performed for this condition.

TABLE III.- MASS CHARACTERISTICS AND INERTIA PARAMETERS FOR LOADINGS POSSIBLE ON THE XN-Q-1 AIRPLANE AND FOR LOADINGS TESTED ON THE 1/18-SCALE MODEL

[Model values converted to corresponding full-scale values; moments of inertia are given about the center of gravity]

a No.	Loading	Weight (lb)	Relative airplane density		Center-of-gravity location		Moments of inertia (slug-ft ²)			Inertia parameters		
			μ (sea level)	μ (10,000 ft)	x/\bar{c}	z/\bar{c}	I_x	I_y	I_z	$\frac{I_x - I_y}{mb^2}$	$\frac{I_y - I_z}{mb^2}$	$\frac{I_z - I_x}{mb^2}$
Airplane												
1	Normal gross weight center of gravity, canopy closed, gear up	3658	4.85	6.58	0.243	0.048	1749	2792	4208	-53×10^{-4}	-72×10^{-4}	125×10^{-4}
2	Most rearward center of gravity, canopy open, gear up	3458	4.59	6.21	.266	.061	1729	2818	4254	-59	-77	136
3	Normal gross weight center of gravity, canopy open, gear up	3658	4.85	6.58	.260	.048	1749	2845	4255	-56	-71	127
Model												
1	Normal gross weight	3808	5.06	6.85	0.250	0.049	1855	2724	4248	-42×10^{-4}	-74×10^{-4}	116×10^{-4}
2	Normal gross weight, center of gravity moved rearward 10 percent of \bar{c}	3761	4.99	6.76	.342	.051	1855	2458	3981	-30	-75	105
3	Normal gross weight, I_y and I_z increased 20 percent of I_y	3792	5.03	6.82	.243	.052	1858	3332	4853	-72	-75	147

^a Numbers correspond to numbered points on figure 5.

CHART 1.- SPIN AND RECOVERY CHARACTERISTICS OF THE $\frac{1}{18}$ -SCALE MODEL OF THE FAIRCHILD XNQ-1 AIRPLANE IN THE NORMAL GROSS-WEIGHT LOADING WITH THE ORIGINAL VERTICAL TAIL
 [Point number 1 in table III and figure 5; recoveries attempted by rapid full rudder reversal except as indicated (recoveries attempted from, and steady-spin data presented for, rudder-full-with spins); right erect spin]

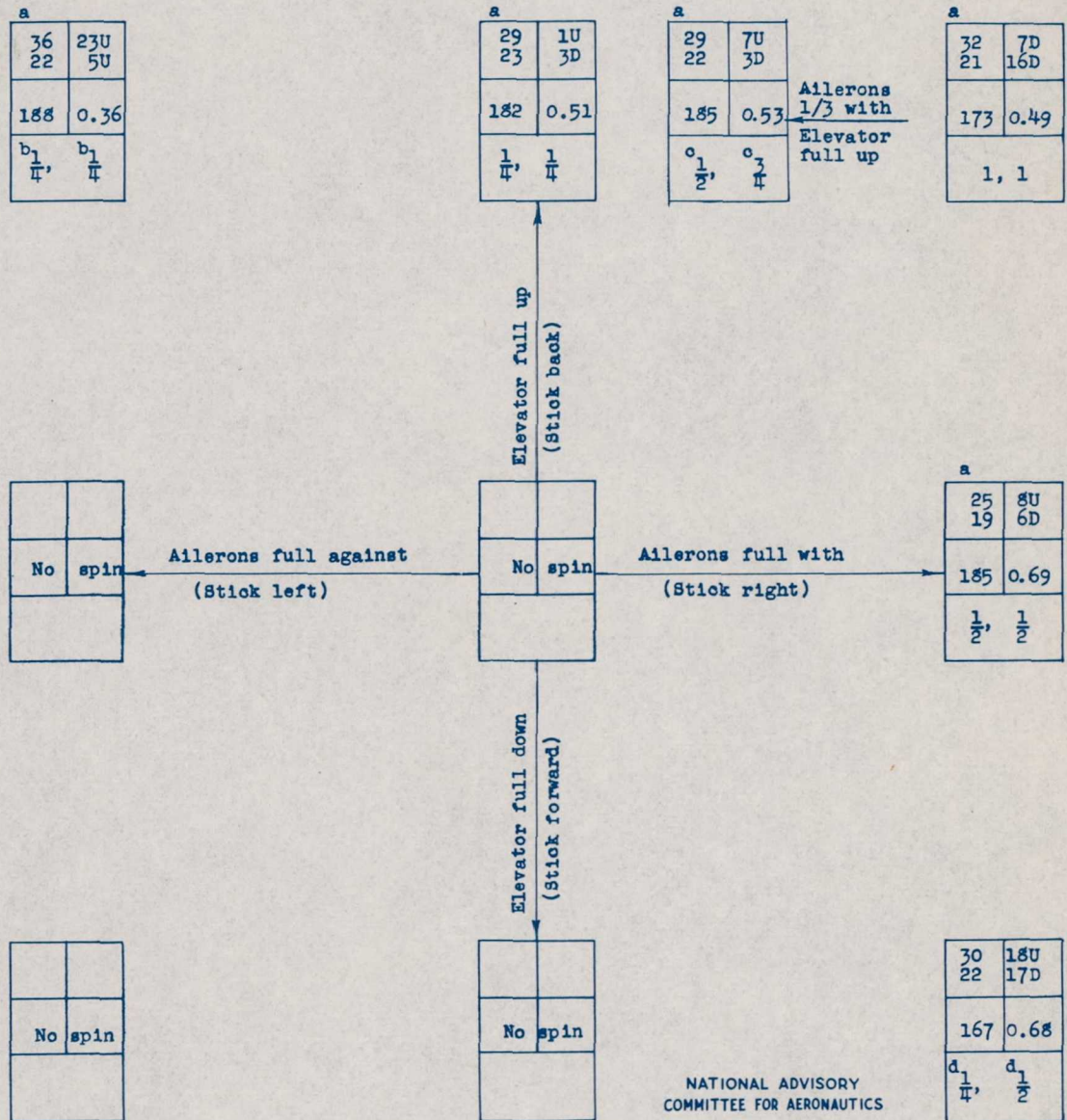

^aOscillatory spin.
^bAfter recovery, model spins in opposite direction before striking safety net.
^cRecovery attempted by reversing rudder to 2/3 against the spin.
^dAfter recovery, model inverts and spins to pilot's left before striking safety net.

Model values converted to corresponding full-scale values.
 U inner wing up
 D inner wing down

NATIONAL ADVISORY COMMITTEE FOR AERONAUTICS

a (deg)	φ (deg)
v (fps)	Ω (rps)
Turns for recovery.	

CHART 2.- INVERTED SPIN AND RECOVERY CHARACTERISTICS OF THE $\frac{1}{16}$ -SCALE MODEL OF THE FAIRCHILD XNQ-1 AIRPLANE IN THE NORMAL GROSS-WEIGHT LOADING WITH THE ORIGINAL VERTICAL TAIL

[Point number 1 in table III and figure 5; recoveries attempted by rapid full rudder reversal except as indicated (recoveries attempted from, and steady-spin data presented for, rudder-full-with spins); inverted spins to pilot's right]

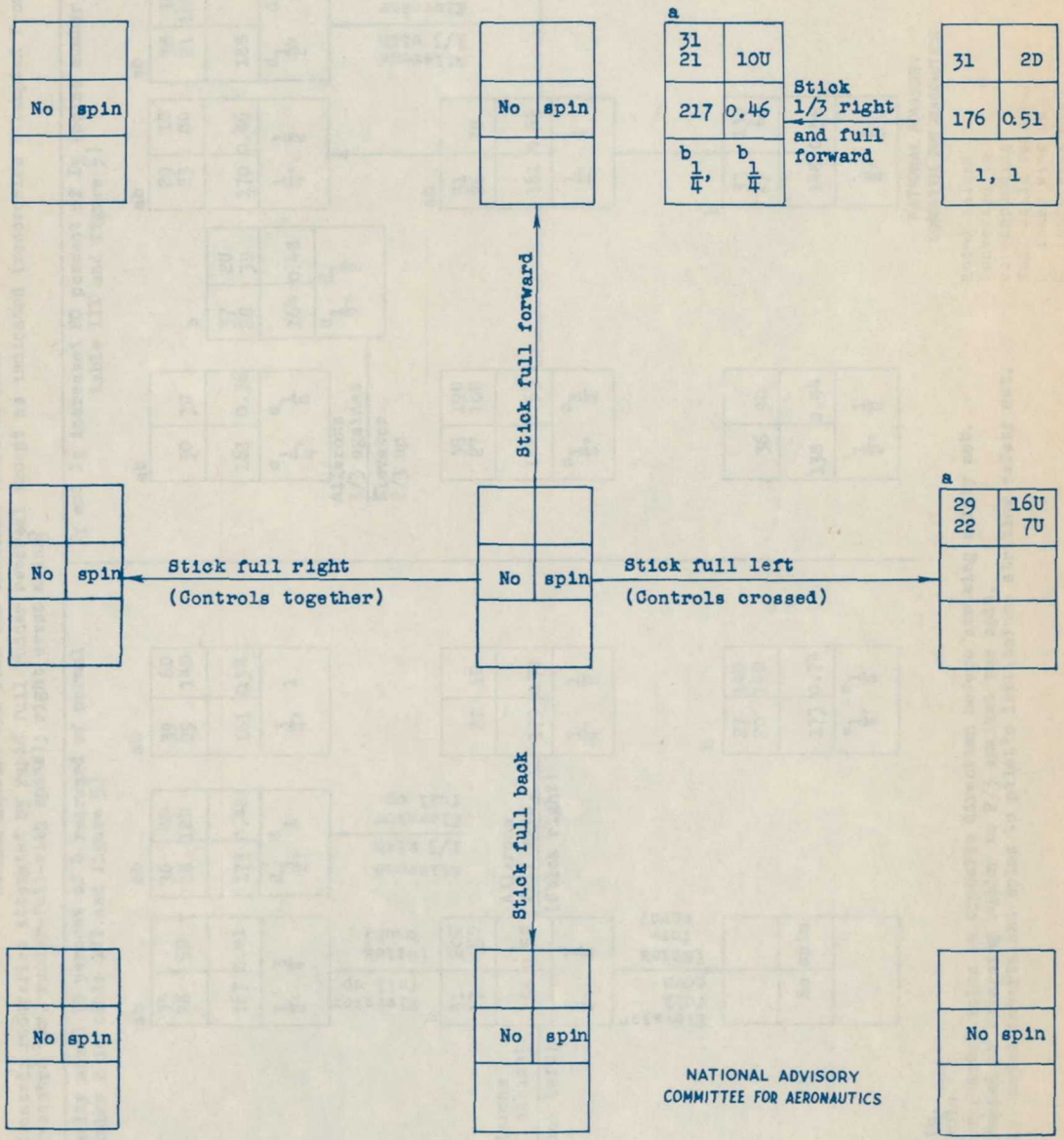

^aOscillatory spin.

^bRecovery attempted by reversing rudder to 2/3 against the spin.

Model values converted to corresponding full-scale values.
 U inner wing up
 D inner wing down

a (deg)	φ (deg)
V (fps)	Ω (rps)
Turns for recovery	

CHART 3.- SPIN AND RECOVERY CHARACTERISTICS OF THE 1/16-SCALE MODEL OF THE FAIRCHILD XNQ-1 AIRPLANE WITH VARIATIONS FROM THE NORMAL LOADING AND WITH THE ORIGINAL VERTICAL TAIL

[Loading as indicated; recoveries attempted by rapid full rudder reversal except as indicated (recoveries attempted from, and steady-spin data presented for, rudder-full-with spines); right erect sping]

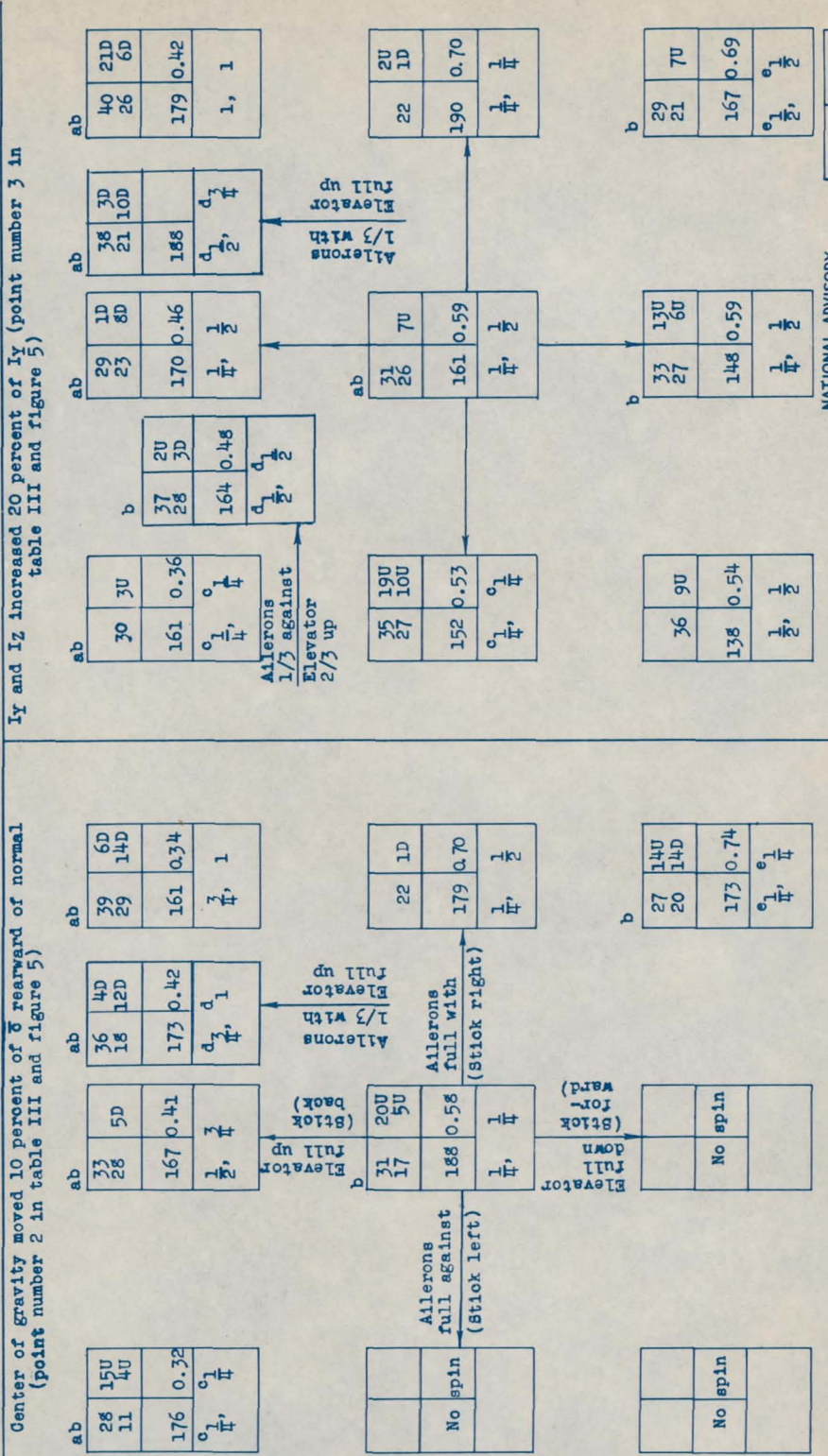

a	ϕ
(deg)	(deg)
V	Ω
(fps)	(rps)
Turns for recovery	

NATIONAL ADVISORY COMMITTEE FOR AERONAUTICS

Model values converted to corresponding full-scale values. U inner wing up D inner wing down

a wandering spin.
 b oscillatory spin.
 c After recovery, model spins in opposite direction before striking safety net.
 d Recovery attempted by reversing rudder to 2/3 against the spin.
 e After recovery, model inverts and spins to pilot's left before striking safety net.

CHART 4.- SPIN AND RECOVERY CHARACTERISTICS OF THE $\frac{1}{18}$ -SCALE MODEL OF THE FAIRCHILD XNQ-1 AIRPLANE IN THE NORMAL GROSS-WEIGHT LOADING WITH THE ALTERNATE VERTICAL TAIL

[Point number 1 in table III and figure 5; recoveries attempted by rapid full rudder reversal except as indicated (recoveries attempted from, and steady-spin data presented for, rudder-full-with spins); right erect spins]

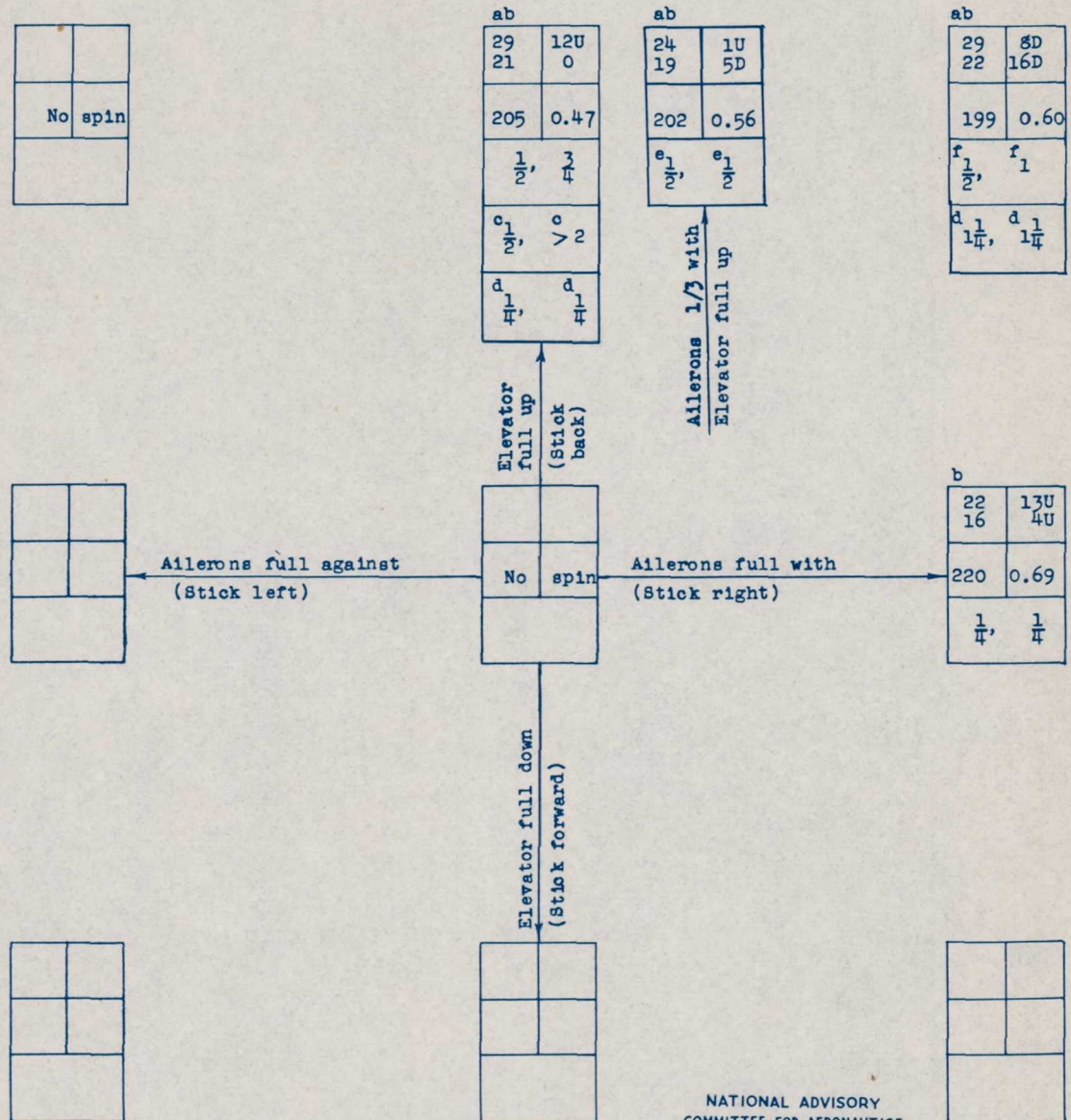

NATIONAL ADVISORY COMMITTEE FOR AERONAUTICS

- ^aWandering spin.
- ^bOscillatory spin.
- ^cRecovery attempted by neutralizing the rudder.
- ^dRecovery attempted by simultaneously neutralizing the rudder and elevator.
- ^eRecovery attempted by reversing the rudder to $\frac{2}{3}$ against the spin.
- ^fModel goes into spiral dive after recovery.

Model values converted to corresponding full-scale values.
 U inner wing up
 D inner wing down

a (deg)	ϕ (deg)
V (fps)	Ω (rps)
Turns for recovery	

CHART 5.- SPIN AND RECOVERY CHARACTERISTICS OF THE 1/8-SCALE MODEL OF THE FAIRCHILD XHQ-1 AIRPLANE WITH VARIATIONS FROM THE NORMAL LOADING AND WITH THE ALTERNATE VERTICAL TAIL.

[Loading as indicated; recoveries attempted as indicated (recoveries attempted from, and steady-spin data presented for, rudder-full-with spins); right erect spins]

Center of gravity moved 10 percent of \bar{c} rearward of normal (point number 2 in table III and figure 5)

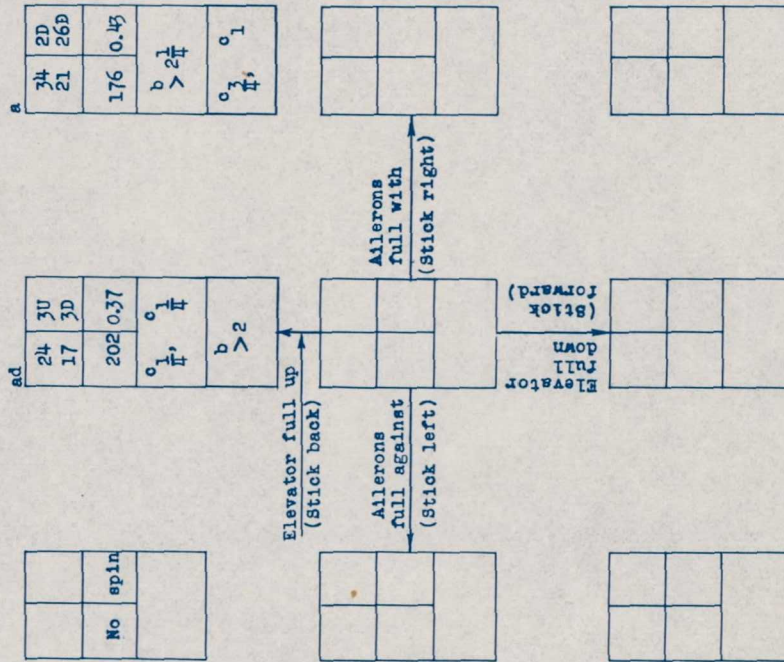

^aOscillatory spin.
^bRecovery attempted by neutralizing the rudder.
^cRecovery attempted by simultaneously neutralizing the rudder and elevator.
^dWandering spin.

Iy and Iz increased 20 percent of Iy (point number 3 in table III and figure 5)

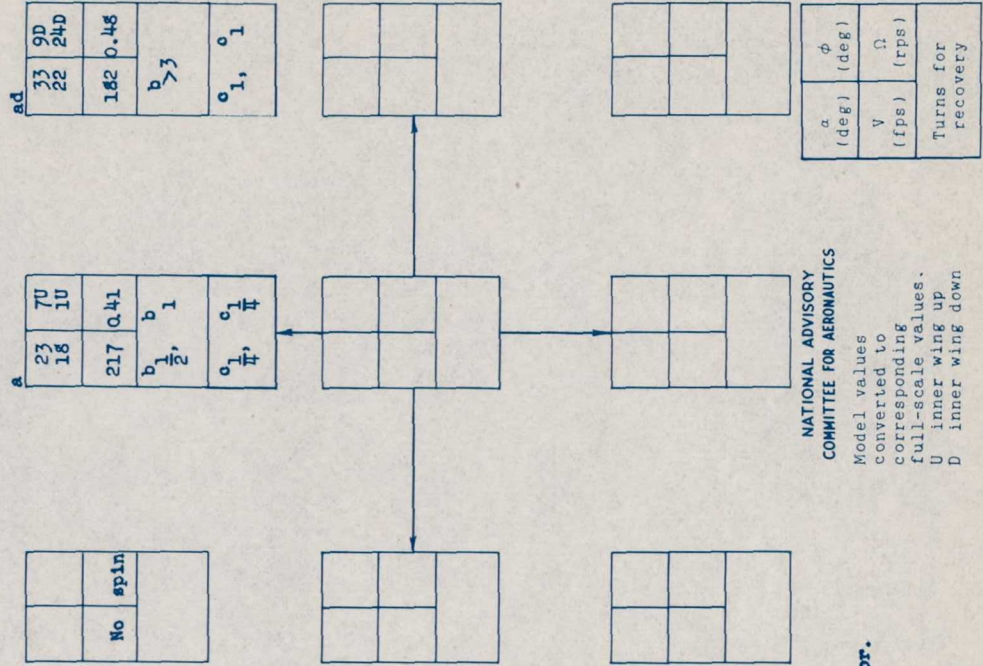

NATIONAL ADVISORY COMMITTEE FOR AERONAUTICS

Model values converted to full-scale values corresponding to inner wing up, inner wing down

a	ϕ
(deg)	(deg)
V	Ω
(fps)	(rps)
Turns for recovery	

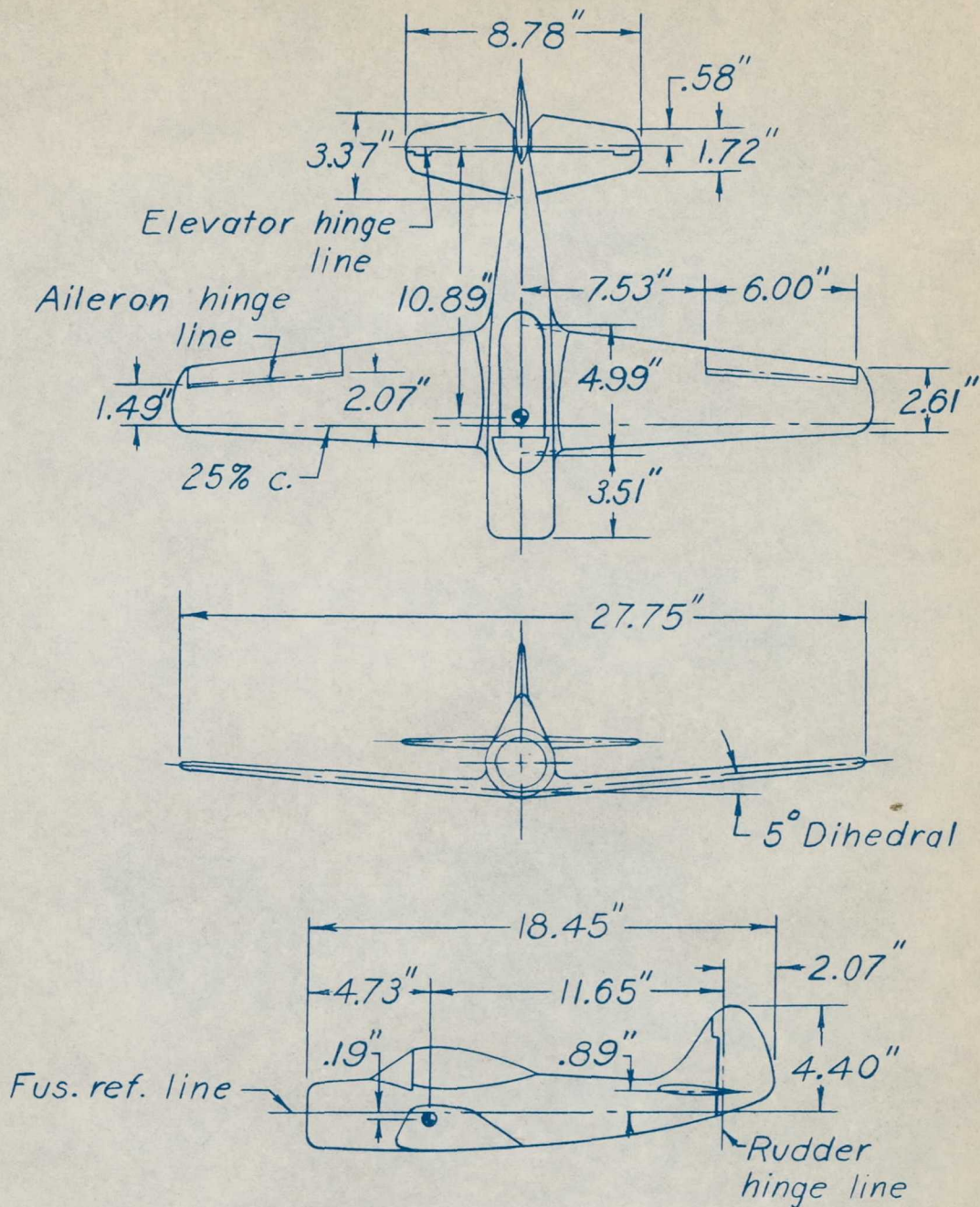

Figure 1.-Three-view drawing of the $\frac{1}{18}$ -scale model of the Fairchild XNQ-1 airplane with the original vertical tail as tested in the free-spinning tunnel. Center of gravity is shown for the normal gross-weight loading.

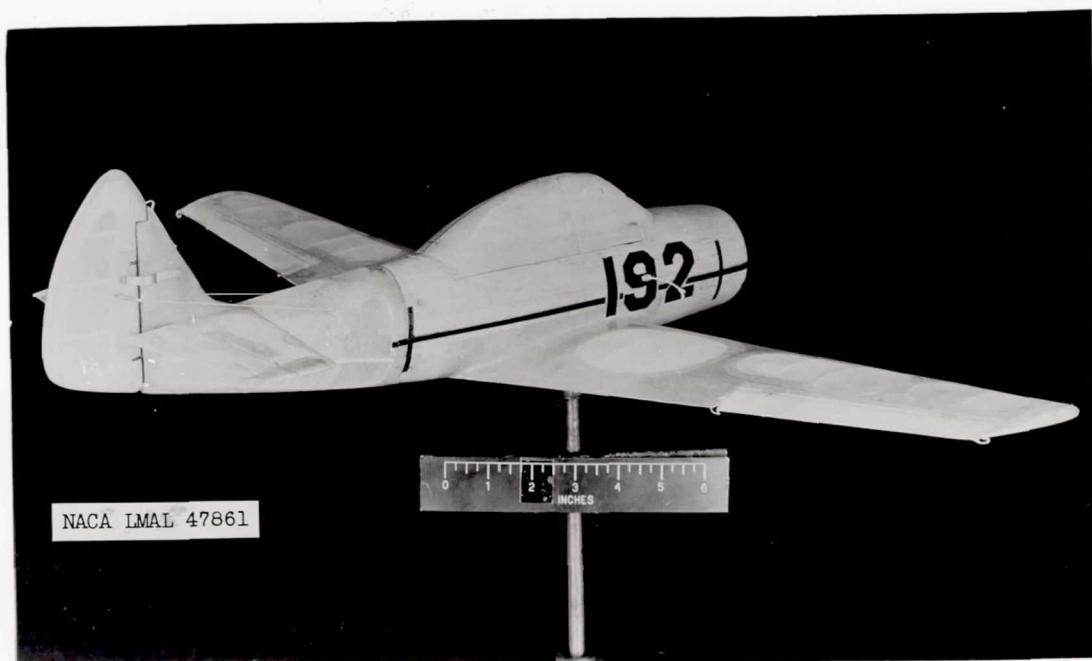
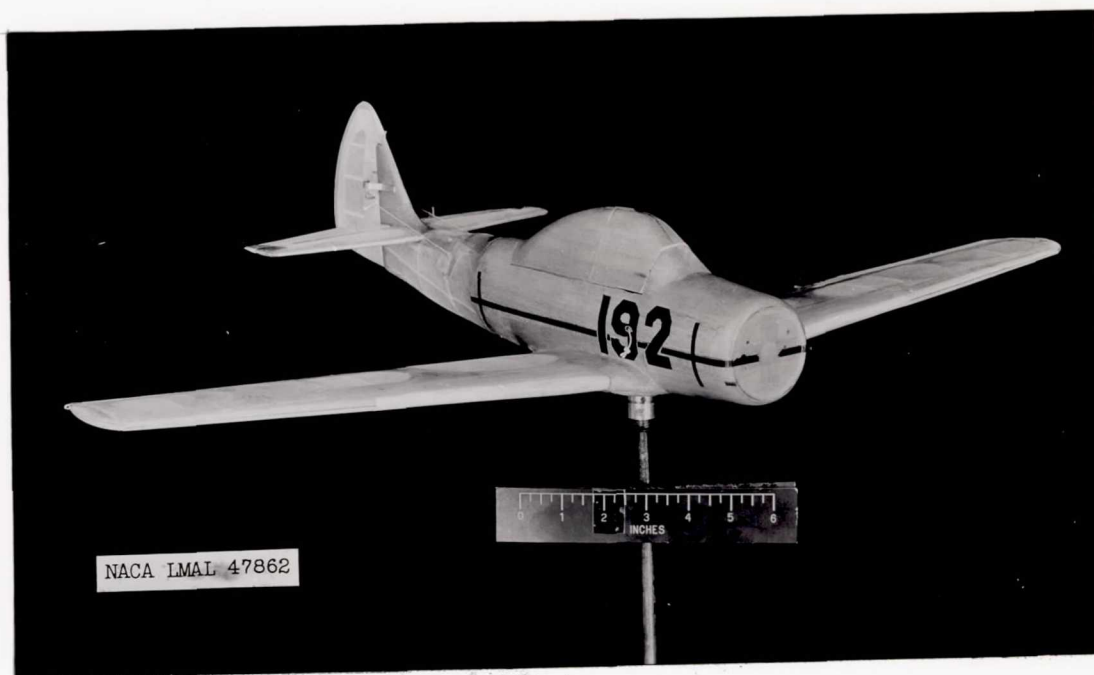

Figure 2.- Photographic views of the $\frac{1}{18}$ -scale model of the XNQ-1 airplane with the original vertical tail installed.

ORIGINAL TAIL ———
ALTERNATE TAIL - - -

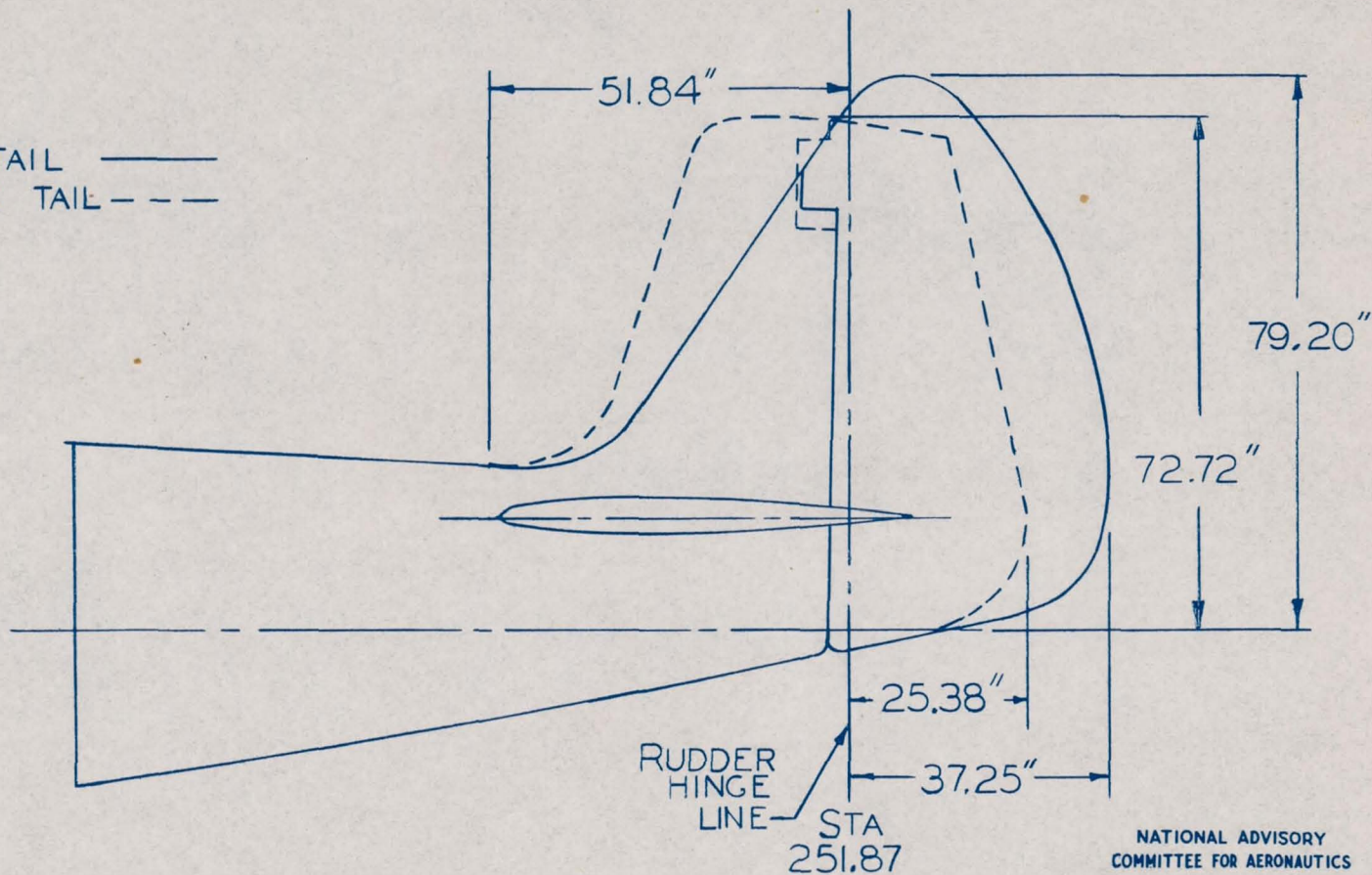

FIGURE 3.- A COMPARISON DRAWING OF THE ORIGINAL AND ALTERNATE VERTICAL TAIL PLANFORMS TESTED ON THE $\frac{1}{18}$ -SCALE MODEL OF THE XNQ-1 AIRPLANE (DIMENSIONS SHOWN ARE FULL-SCALE)



Figure 4.- Photograph of the $\frac{1}{18}$ -scale model of the XNQ-1 airplane spinning in the Langley 20-foot free-spinning tunnel.

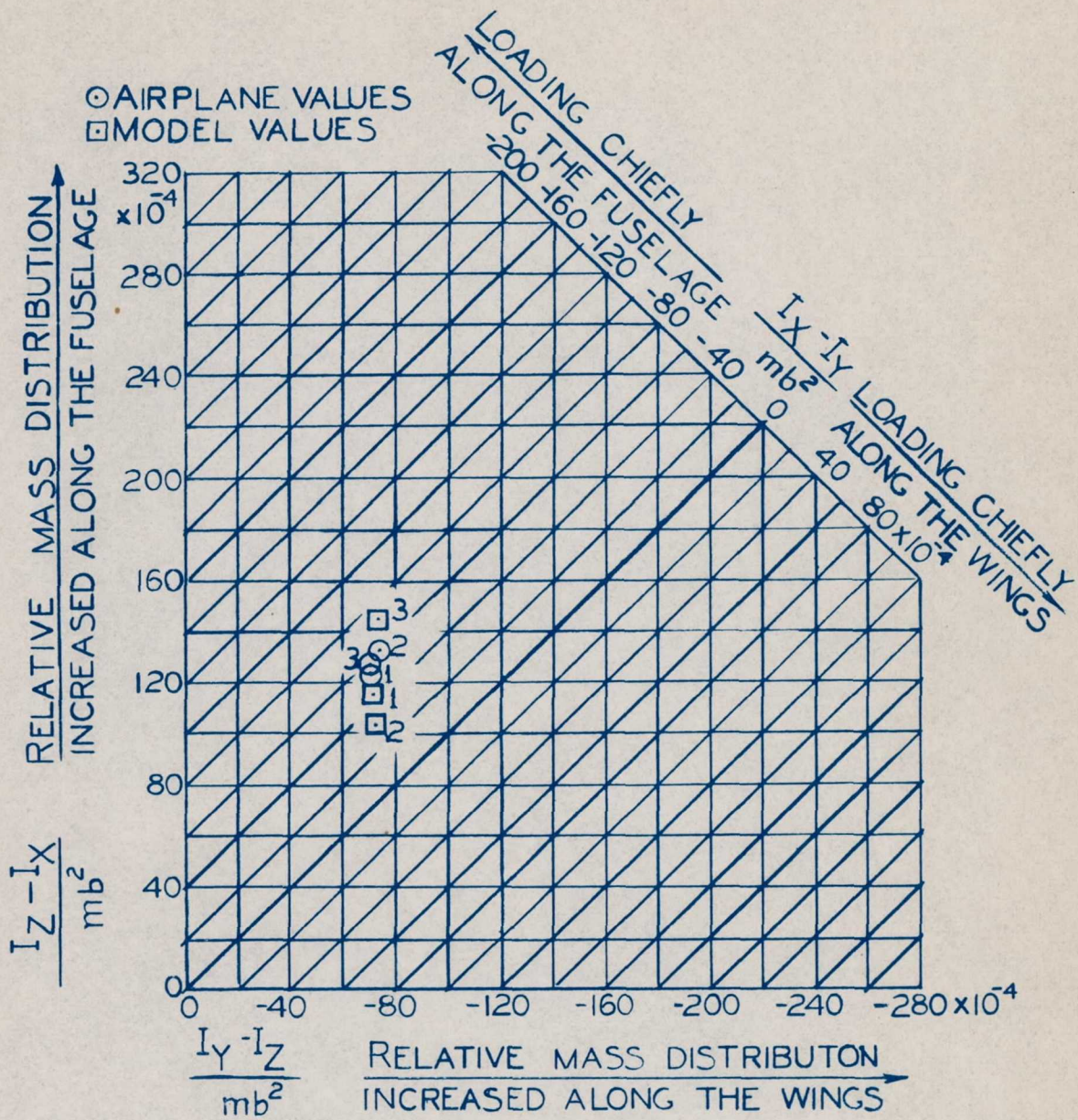

FIGURE 5.- INERTIA PARAMETERS FOR LOADINGS POSSIBLE ON THE XNQ-1 AIRPLANE AND FOR THE VARIOUS LOADINGS TESTED ON THE MODEL.

(POINTS ARE FOR LOADINGS LISTED ON TABLE III)