

Hybrid Turbine Electric Vehicle



Hybrid electric power trains may revolutionize today's ground passenger vehicles by significantly improving fuel economy and decreasing emissions. The NASA Lewis Research Center is working with industry, universities, and Government to develop and demonstrate a hybrid electric vehicle. Our partners include Bowling Green State University, the Cleveland Regional Transit Authority, Lincoln Electric Motor Division, the State of Ohio's Department of Development, and Teledyne Ryan Aeronautical.

The vehicle will be a heavy class urban transit bus offering double the fuel economy of today's buses and emissions that are reduced to 1/10th of the Environmental Protection Agency's standards. At the heart of the vehicle's drive train is a natural-gas-fueled engine. Initially, a small automotive engine will be tested as a baseline. This will be followed by the introduction of an advanced gas turbine developed from an aircraft jet engine. The engine turns a high-speed generator, producing electricity. Power from both the generator and an onboard energy storage system is then provided to a variable-speed electric motor attached to the rear drive axle. An intelligent power-control system determines the most efficient operation of the engine and energy storage system.

Hybrid electric power trains offer several advantages for vehicle performance and emissions. First, the load seen by the engine is decoupled from the short-term power requirements of the vehicle. With constant load, the engine can be designed to operate nearly continuously at its highest efficiency point. In addition, the size of the engine can be reduced significantly in most vehicles to the long-term average value of power. The electric drive train provides additional benefits by eliminating losses in the fluid couplings of conventional automatic transmissions. Finally, electric drive trains can recover energy as the vehicle brakes, further improving fuel economy. Gas turbines offer the additional benefits of being lightweight, using multiple fuels, and having high reliability and very low emissions.

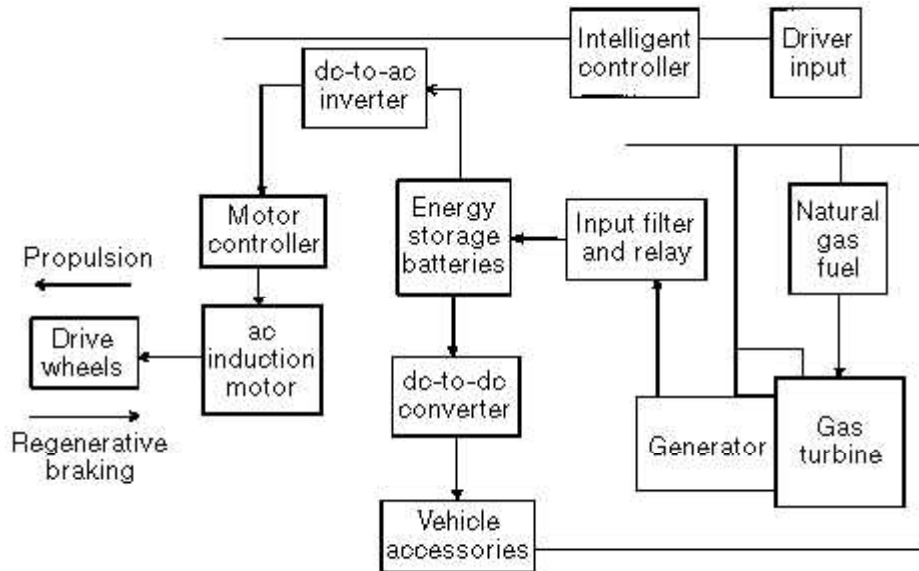

Power and control diagram.

In addition to initiating and coordinating the overall project, the NASA Lewis Research Center is performing much of the system engineering for the vehicle's electrical power system. A computer program called Hybrid Electric Vehicle Analysis (HEVA) has been developed to calculate vehicle performance and power requirements. Lewis is also developing the power control software and integrating an advanced capacitor system for energy storage. In addition, Lewis combustion test facilities are being used to support the gas turbine engine development. Initial operation of the prototype vehicle is scheduled for the First Quarter of 1997.

Potential markets for this vehicle include regional transit authorities in both the Northeast and California, who have already shown a great interest in fuel-efficient, low-emission transit buses. In addition to city transit buses, this technology has applications for many other ground vehicles, including automobiles, delivery vehicles, municipal waste trucks, school buses, and shuttle buses. Manufacturing methods developed for these markets will also return benefits to the aerospace industry through lower cost engines for small aircraft.

Lewis contact: Dr. Larry A. Viterna, (216) 433-5398, viterna@grc.nasa.gov

Author: Dr. Larry A. Viterna

Headquarters program office: OSF (Space Station)