

# Feasibility Study of a Nuclear-Stirling Power Plant for the Jupiter Icy Moons Orbiter

Paul C. Schmitz<sup>1</sup>, Jeffrey G. Schreiber<sup>2</sup>, and L. Barry Penswick<sup>3</sup>

<sup>1</sup>Power Computing Solutions, Inc., Avon, OH 44011,

<sup>2</sup>NASA Glenn Research Center at Lewis Field, MS 301-2, 21000  
Brookpark Road, Cleveland, OH 44135

<sup>3</sup>L. Barry Penswick Consulting, Stevenson, WA 98648  
(216) 433-6174, Paul.C.Schmitz@grc.nasa.gov

**Abstract** NASA is undertaking the design of a new spacecraft to explore the planet Jupiter and its three moons Calisto, Ganymede and Europa. This proposed mission, known as Jupiter Icy Moons Orbiter (JIMO) would use a nuclear reactor and an associated electrical generation system (Reactor Power Plant – RPP) to provide power to the spacecraft. The JIMO spacecraft is envisioned to use this power for science and communications as well as Electric Propulsion (EP). Among other potential power-generating concepts, previous studies have considered Thermoelectric and Brayton power conversion systems, coupled to a liquid metal reactor for the JIMO mission. This paper will explore trades in system mass and radiator area for a nuclear reactor power conversion system, however this study will focus on Stirling power conversion. The Stirling converter modeled in this study is based upon the Component Test Power Converter design that was designed and operated successfully under the Civil Space Technology Initiative for use with the SP-100 nuclear reactor in the 1980's and early 1990's. The study design is such that two of the four converters would operate at any time to generate the 100 kWe while the others are held in reserve. For this study the Stirling converters hot-side temperature is 1050 K, would operate at a temperature ratio of 2.4 for a minimum mass system and would have a system efficiency of 29%. The Stirling converter would generate high voltage (400 volt), 100 Hz single phase AC that is supplied to the Power Management and Distribution system. The waste heat is removed from the Stirling converters by a flowing liquid sodium-potassium eutectic and then rejected by a shared radiator. The radiator consists of two coplanar wings, which would be deployed after the reactor is in space. System trades were performed to vary cycle state point temperatures and converter design as well as power output. Other redundancy combinations were considered to understand the affects of converter size and number of spares to the system mass.

# **Feasibility Study of a Nuclear-Stirling Power Plant for the Jupiter Icy Moons Orbiter**

The work in this paper was performed for NASA Headquarters, Exploration Systems Mission Directorate (Code T).  
any opinions expressed are those of the authors and do not necessarily reflect the views  
of the Exploration Systems Mission Directorate.

Presented by Paul C. Schmitz

Co-authors: Jeffrey G. Schreiber, and L. Barry  
Penswick

**Glenn Research Center**



---

at Lewis Field

## Presentation Overview

- Past high power Stirling convertors
- Components which make up the system
- Requirements/Assumptions
- Results of system study

**Glenn Research Center**

at Lewis Field





# Analysis Overview

- Develop a conceptual design of a lithium cooled fast reactor coupled to a Stirling convertor power plant for the JIMO

## Mission

- Why was this study performed?
  - During the SP-100 era Stirling was picked as the dynamic power system of choice because of its attractive mass and radiator area when compared with other power conversion systems
  - We wanted to take a fresh look at both the CTPC heritage convertor designs and a updated Stirling convertor design and study its mass and radiator area characteristics for a JIMO mission

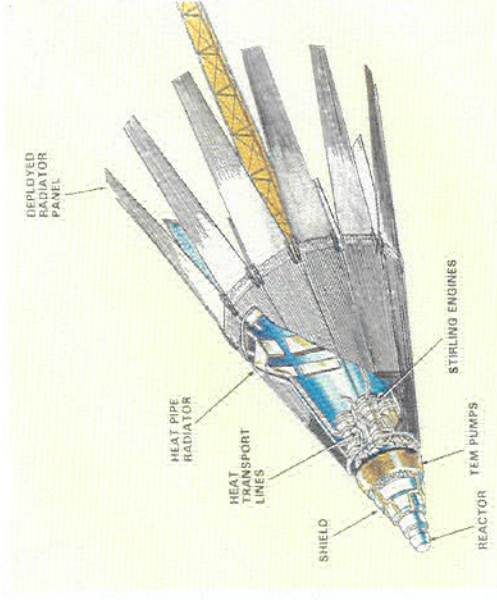

SP-100 era system design

**Glenn Research Center**



at Lewis Field



# SP-100 Era Development

- **SPDE (Space Power Demonstrator Engine)**
  - Demonstrated 13 kW per piston (SOA was 3kW)
  - Demonstrated opposed-synchronous operation with common expansion space for dynamically balanced operation
  - Demonstrated high efficiency operation at low temperature ratio of 2.0
  - Demonstrated non-contacting operation for long life
  - Designed for nominal room temperature at cold end, therefore ran at ~650K/325K (377°C/52°C)
  - Used molten salt at hot end, water at cold end through tube and shell heat exchangers
  - Designed and built in 16 months by Mechanical Technology Incorporated

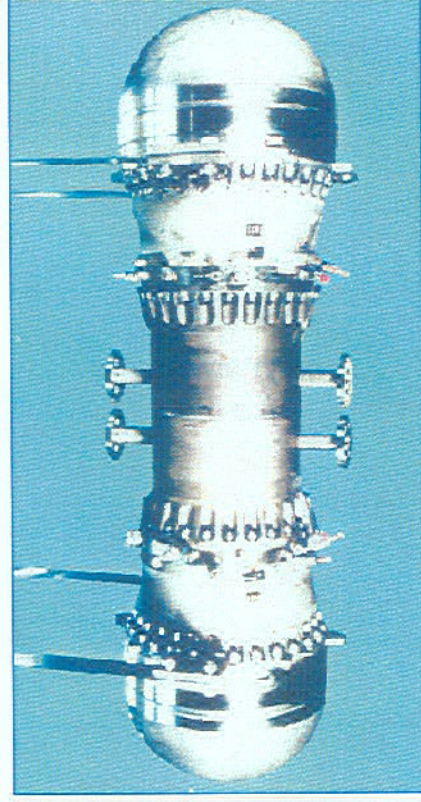
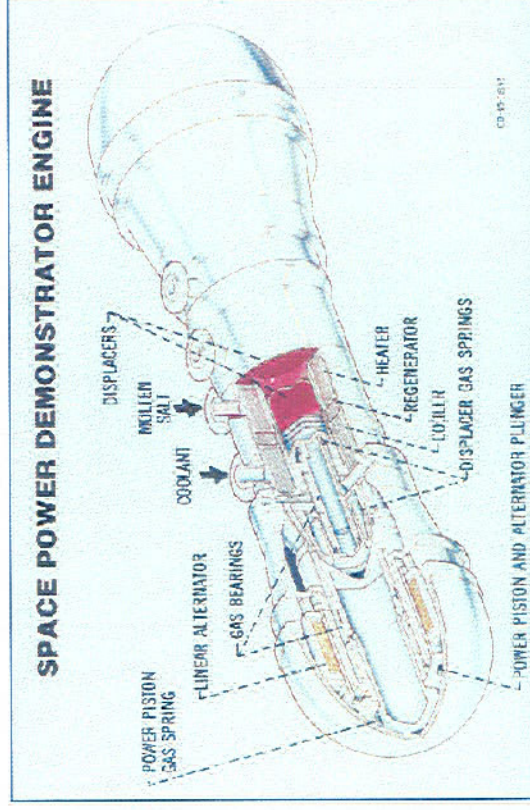

at Lewis Field

**Glenn Research Center**



# SP-100 Era Development

- SPRE (*Space Power Research Engine*)
  - SPDE was converted into two SPRE's
  - Achieved over 12.5 kWe power per cylinder and ~17% efficiency
  - Dynamic balancer was designed and tested
  - Research was performed with the casing attached to a mass to reduce vibration since dynamically balanced operation had been successfully demonstrated
  - Research sensitivity to changes in heat exchanger and bearing configurations
  - Tested with both hydrostatic and hydrodynamic bearings
  - Data was used to further validate codes
  - Reduced mass linear alternator was designed and fabricated, but not tested

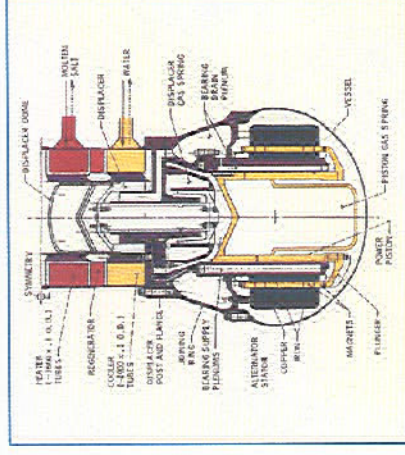

**Glenn Research Center**

at Lewis Field





# SP-100 Era Development

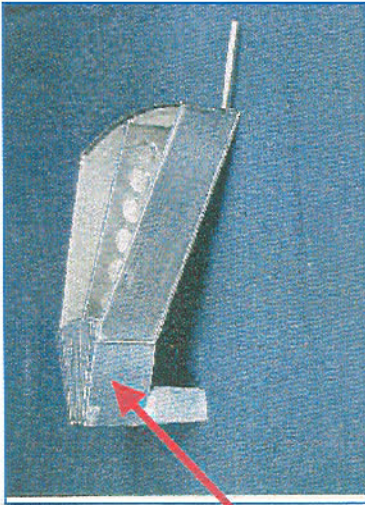

Prototype of hot end heat exchanger

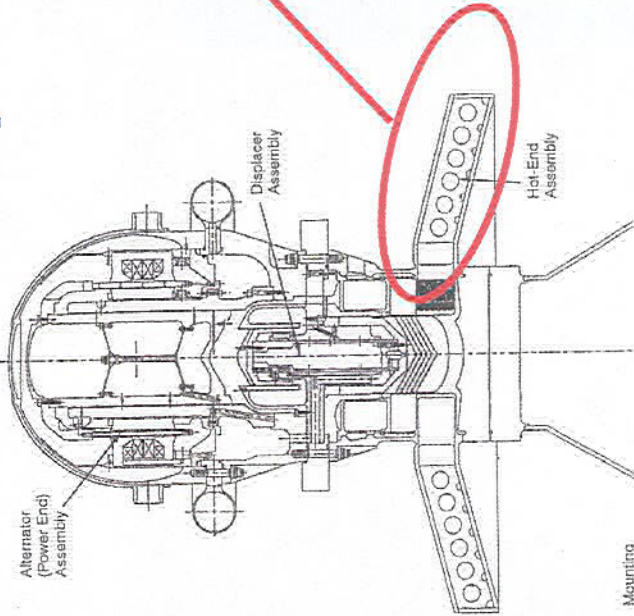

Half of CTPC in test configuration

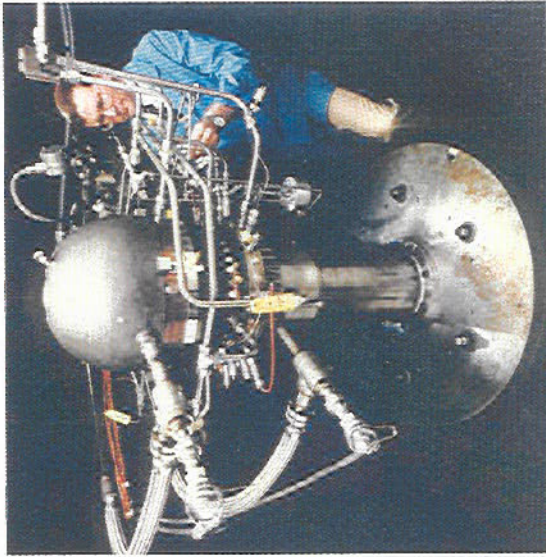

Half of a CTPC being prepared for test

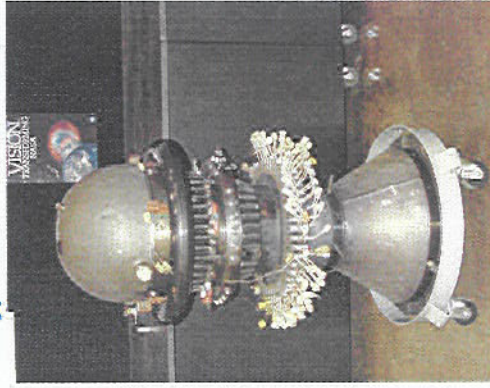

CTPC at GRC 2/2005

- CTPC (*Component Test Power Converter*)
  - Designed for temperature ratio of 2.0 at 1050K/525K
  - Heater head was designed to use Udimet 720
  - Test hardware was fabricated with IN718 for ease of fabrication and initial demonstration
  - Achieved performance goals of 12.5 kWe / 22% efficiency "out-of-the-box" (heat in to AC electric output)
  - 1500 hour test completed at 800K/400K with brief testing at 1050K (777°C)
  - Tested with sodium heat pipe integrated into "Starfish" heater head to minimize hot-end joints
  - Cold-end interface was not prototypical

**Glenn Research Center**

at Lewis Field





# Requirements/Assumptions

- 20 year life
- Use a SP-100 heritage reactor
- Reactor system model identical to those used for Brayton/TE systems modeling at GRC
- Reactor/Stirling interface based upon work done during SP-100 and uses Starfish HX
- Baseline Heater Head Temperature to those estimated during CTPC development - 1050 K
- Perform trades to find minimum mass system
  - 50 kWe to 300 kWe Net Output considered
- Perform "What if" analysis by updating CTPC to current SOA performance



**Glenn Research Center**

at Lewis Field





## What is Unique about Stirling Converter Based Power Plants?

- Stirling Convertors are relatively high efficiency heat to electric convertors (as measured as a fraction of Carnot)
  - Very efficient in their use of temperature ratio and can operate at low temperature ratios ( $TR = 1.8$ )
- From kWe to 100's of kWe their specific mass is relatively constant (kg/kWe)
- Stirling Convertors operate best when heat input and heat rejection occur at nearly constant temperature

**Glenn Research Center**

at Lewis Field



# System Components

- **Reactor and Shield**
- **Primary Heat Transport System**
- **Lithium to Stirling He Heat Exchanger**
- **Stirling Converter**
- **Pumps**
- **Coolant Loop**
- **Radiator**

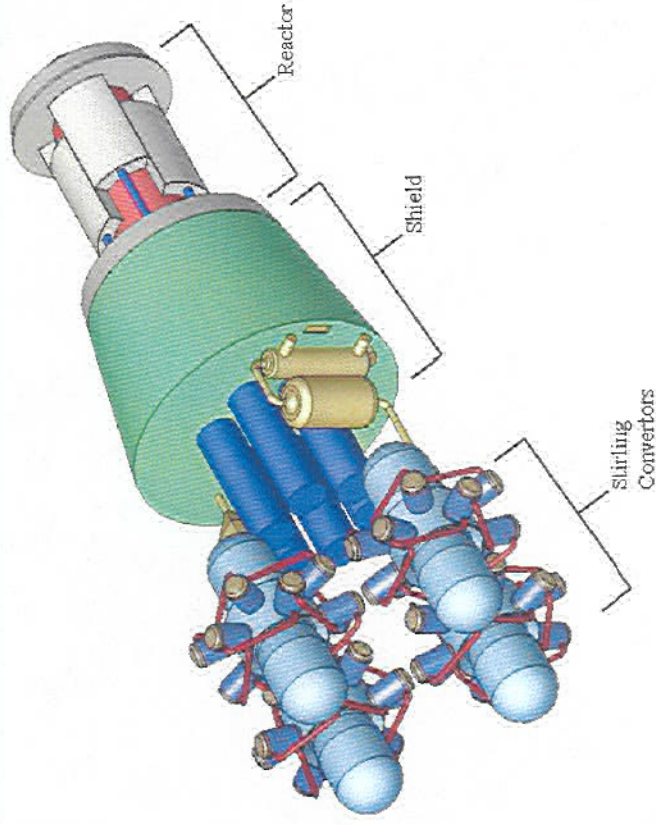

**Glenn Research Center**

at Lewis Field





# System Layout

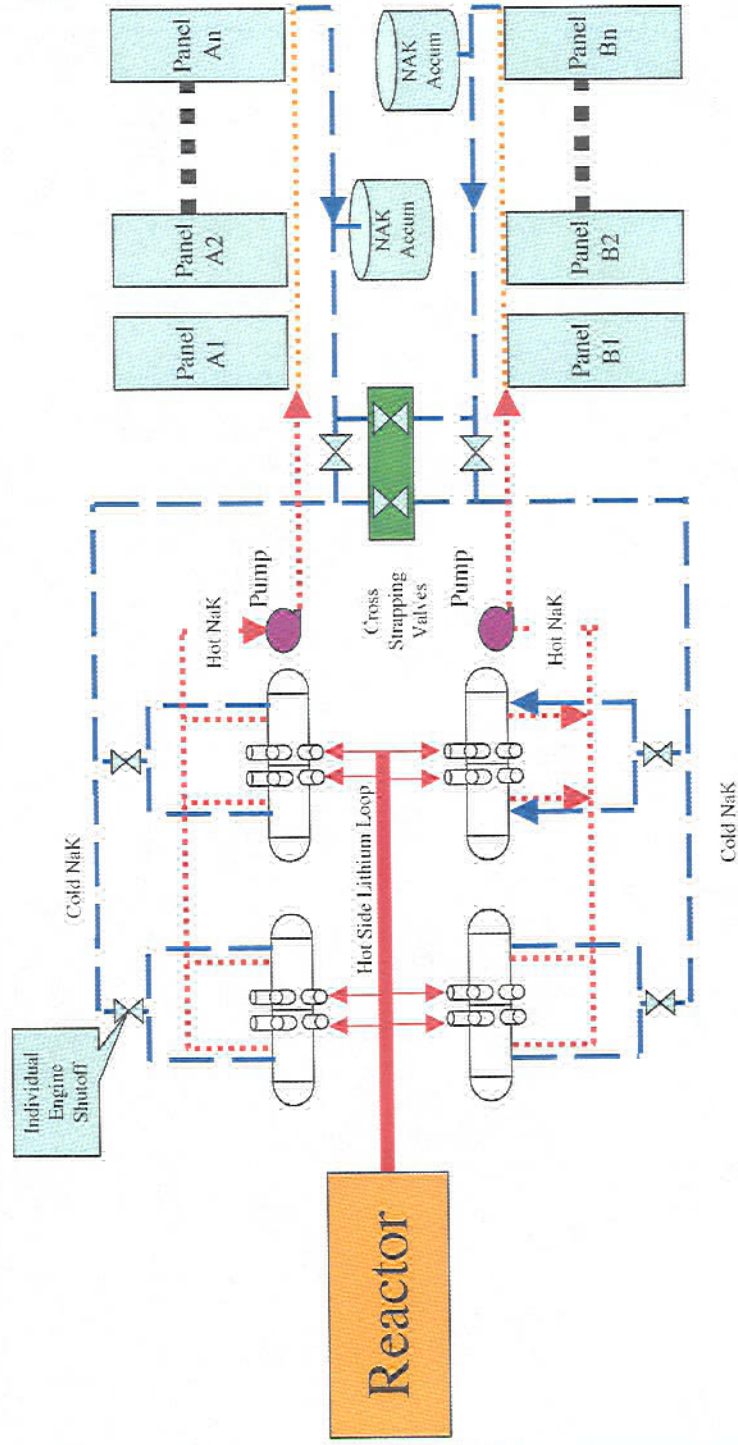

Glenn Research Center

at Lewis Field



# Starfish Overview

- What is the Starfish HX?
  - A heat exchanger design to input the heat into the Stirling He gas
  - Condenser end of a Na heat pipe
- Lithium Coolant from reactor exits reactor at 1350 K and enters at 1250 K
- High temperature lithium flows over Stirling evaporator heat pipes
- Lithium flow is distributed and passed over 10 Heat pipes per dual opposed converter
- Varying thickness of zirconia control heat flux into evaporator to a maximum of 40 w/cm<sup>2</sup>
- Molybdenum is used to prevent O<sub>2</sub> material transport
- Evaporator/Adiabatic section adds about 1 kg/kWe to a dual opposed converter

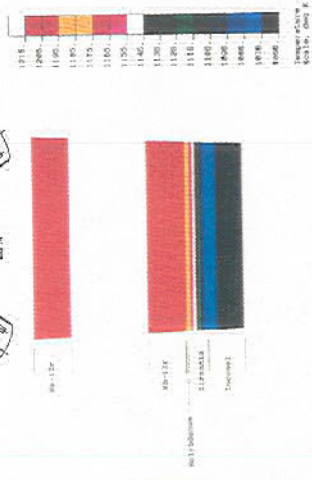
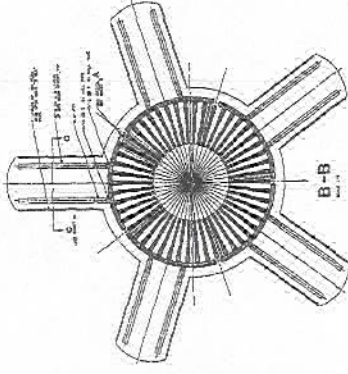
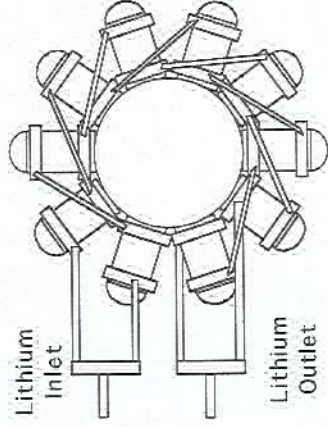
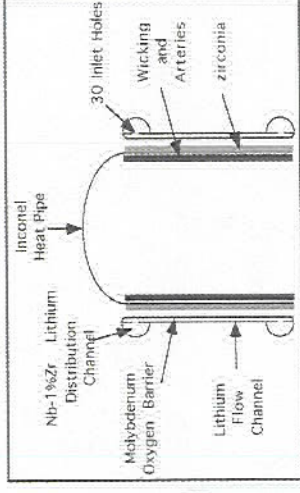
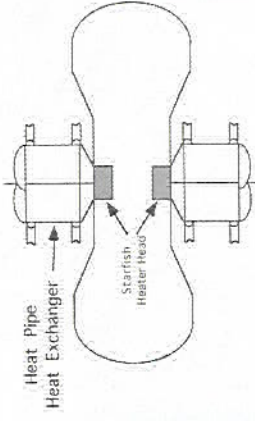

STARFISH HEAT EXCHANGER  
 CONCEPTUAL DESIGN  
 1998-1999



Glenn Research Center

at Lewis Field





# Cold End Fluid Loop and Radiators

- Assumed a NaK liquid metal system
- Converter efficiency is directly related to the temperature rise across its cold end
- Scaling Study had a 10 K temperature rise across cold end of converter
- Radiator loop delta T optimized at 40 K for minimum mass (looked from 10 to 100 K)
- Pumping power is a significant power consumer
- Water heat pipes are used to reject waste heat

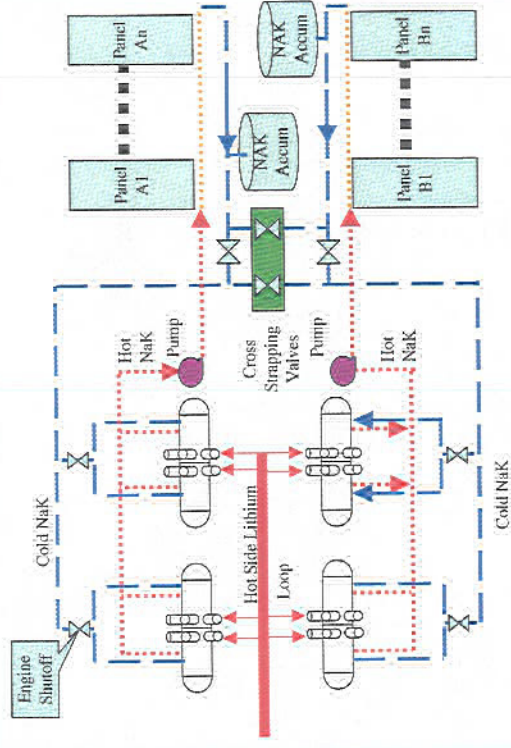
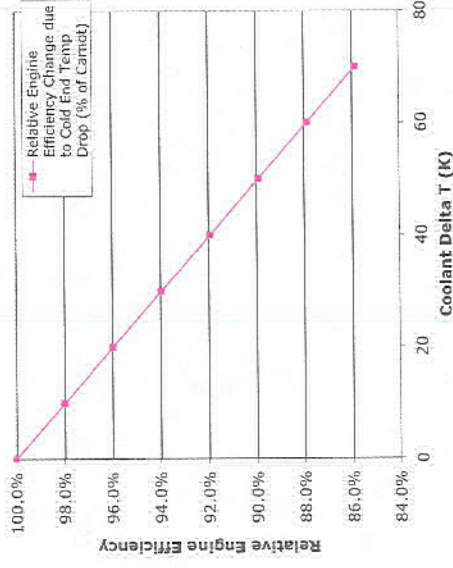

Glenn Research Center

at Lewis Field



# 100 kWe Stirling System

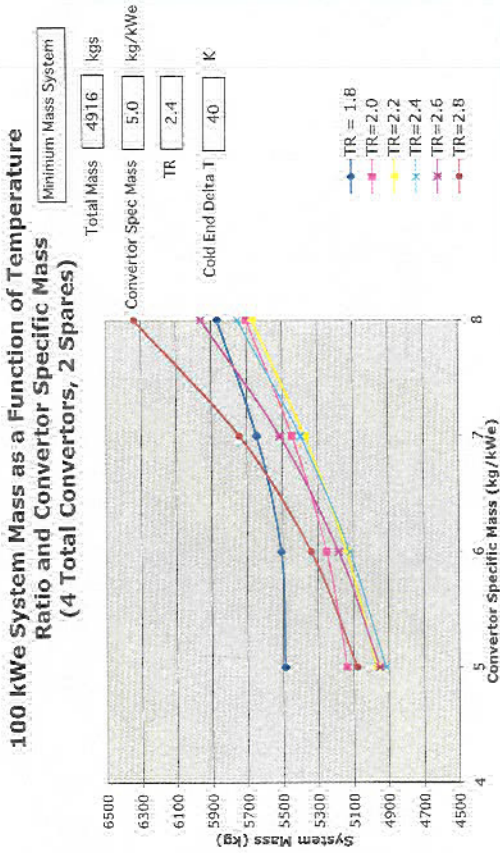

- 1050 K heater head
- Vary converter specific mass, temperature ratio and cold end temperature drop to find system trends
- For all temperature ratios considered the minimum mass point occurred at the lowest specific mass converter
- Minimum system mass occurred at a temperature ratio of 2.4, a converter specific mass of 5.0 kg/kWe and a cold end fluid temperature drop of 40 K

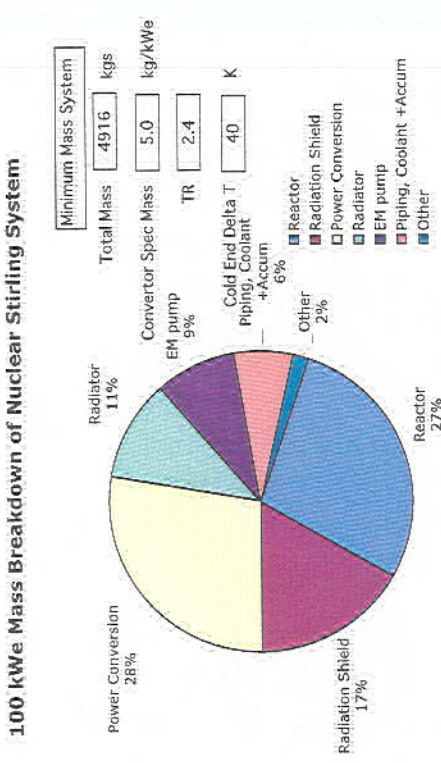

Glenn Research Center

at Lewis Field



# Power Output Variations

- System Mass and radiator area scale relatively linearly with power output
- Converter is a significant fraction of total system mass
  - 100% excess capacity
  - Suggests taking advantage of Stirling relatively flat specific mass as a function of power level and not carry as much excess capacity
- Minimum mass temperature ratios for this system range from 2.2 to 2.4 from 50 to 300 kWe
- System is always driven to lowest specific mass converters rather

Mass and Power as a Function of Power Level for a Liquid Lithium Cooled Reactor Coupled to a Stirling Converter 1050 K Heater Head

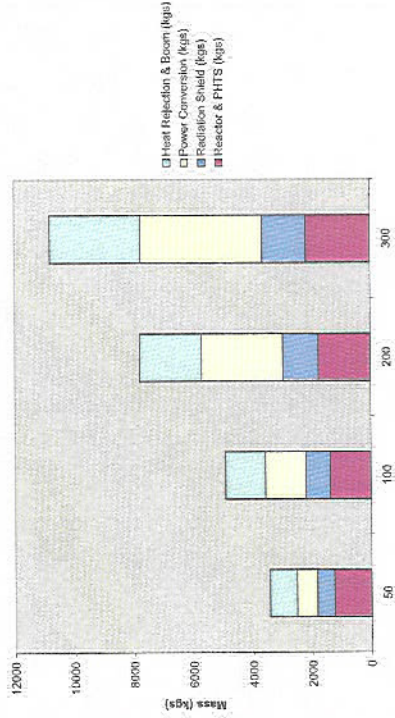

Radiator Area as a Function of Power Level for a Liquid Cooled Reactor Coupled to a Stirling Converter 1050 K Heater Head

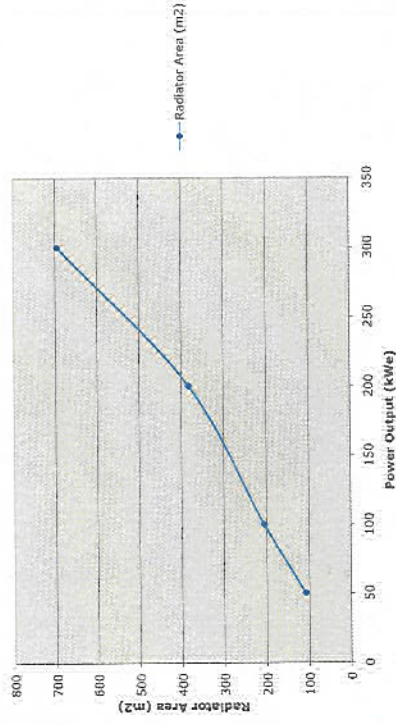

Glenn Research Center

at Lewis Field





# System Analysis Overview

## Comparison with Minimum Mass System

- When operated at other than the minimum mass design point Stirling systems offer relatively slow variations in power system mass as both converter specific mass and cold end temperature are varied

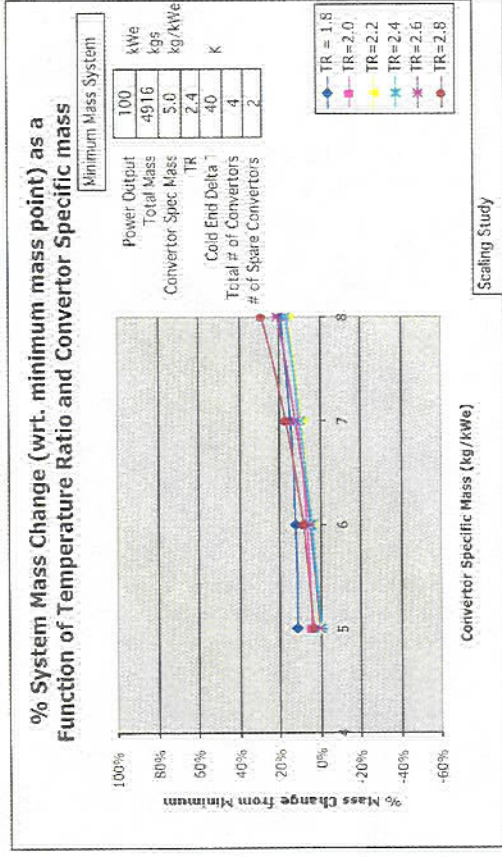

- Radiator area changes relatively quickly at off design allowing the system integrator the ability to select a relatively low mass penalty for a significant reduction in radiator area
- EX: For a 100 kWe System and moving from the optimal TR=2.4 to 2.0 increases the mass by about 5% while decreasing the radiator area by 34%

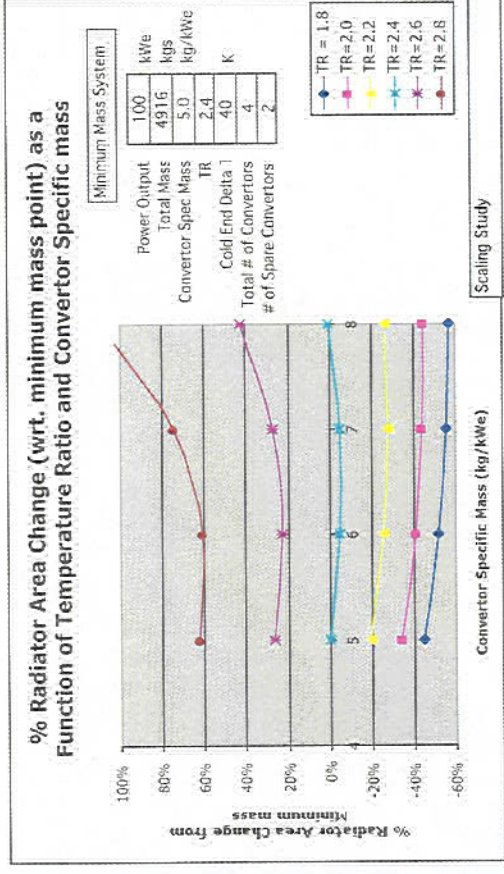

at Lewis Field

**Glenn Research Center**



# Updated Stirling CTPC Scaling Study

- Since the design of the CTPC, significant progress has been made in understanding gas dynamics, alternator design, and materials
- This has an impact on all Stirling developments and has been incorporated in cryocoolers and Stirling power converters in use today
- Applying this knowledge to the CTPC, would provide a lower mass converter with higher efficiency

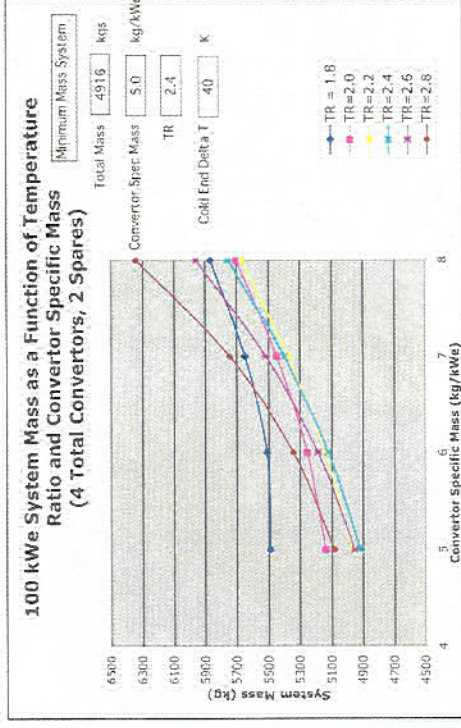

## Updated Scaling Study

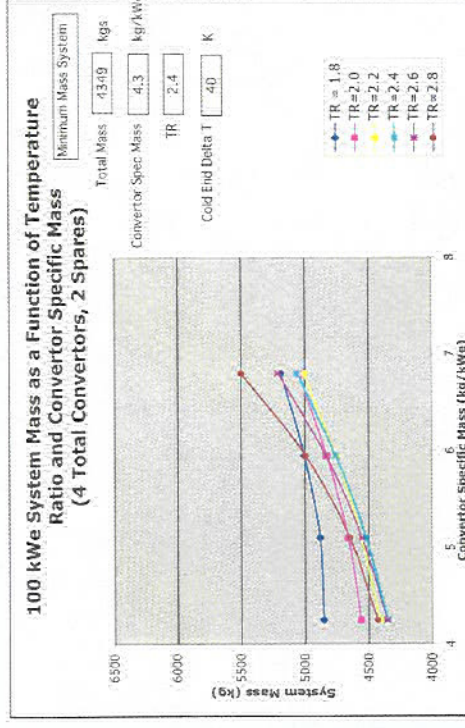

Parameter	CTPC	Updated Stirling Scaling
Thermodynamics	Best practice of the time	Greatly improved with oscillating flow tests and CFD
Operating frequency	70 Hz	100 to 110 Hz
Linear alternator	<90% efficient	>90% efficient with no mass increase. Advanced technology options available with cooling have >90% efficiency with reduced mass.
Seals and bearings	Complex ported hydrostatic bearing with about 8% power consumption	More simple designs have been developed and proven with greatly reduced power consumption
Operating pressure	150 bar	Up to 250 bar
Structure	Best practice of the time	Greatly improved analytical tools, manufacturing, and materials
Heat exchangers	Hot-end complex with good performance, cold end not integrated	Retain heat pipes for hot end, improve cold end integration with radiator and pumps at the system level
Effect on efficiency	23%	31 to 33%

**Glenn Research Center**

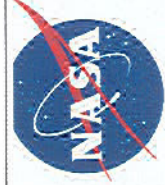

at Lewis Field



# PIE Charts of Updated Stirling at 100 kWe

## CTPC Scaling

100 kWe Mass Breakdown of Nuclear Stirling System

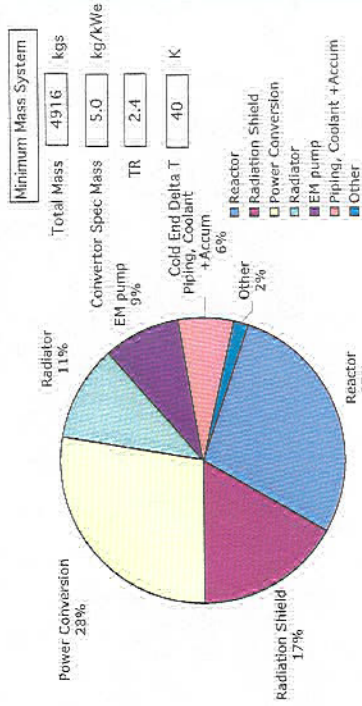

## Updated CTPC Scaling

100 kWe Mass Breakdown of Nuclear Stirling System

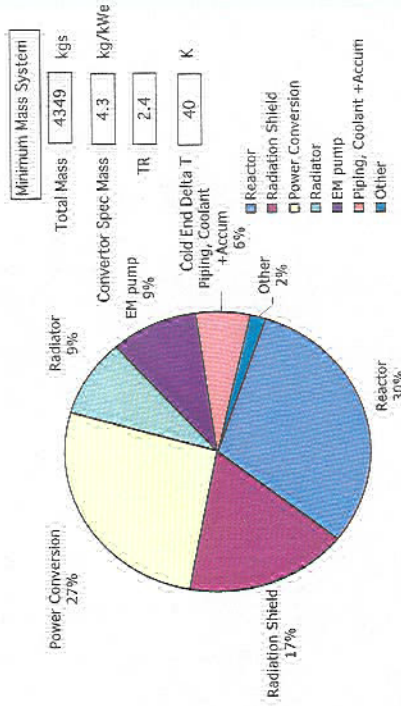

Glenn Research Center

at Lewis Field



# System Analysis Overview

## Optimized Stirling Systems (Minimum Mass)

- 50 to 300 kWe
- Optimized temperature ratio about 2.4
- Cold end maximum temperature for this temperature ratio is about 170 C, potentially allowing water to be used
- CTCP vs. Updated CTPC
- Mass reductions of about 5%
- Radiator area reductions of about 10%

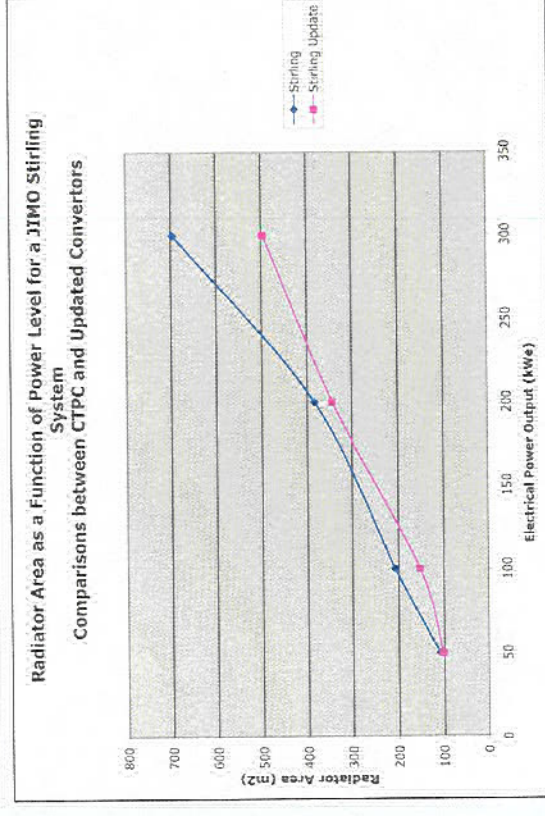
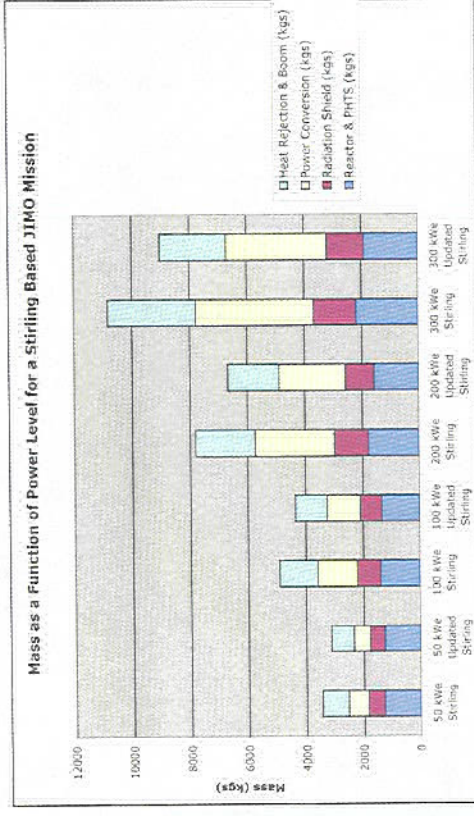

at Lewis Field

Glenn Research Center



## Conclusion

- Stirling power conversion offers a low mass, high efficiency, system flexibility, and has flight development heritage
- Offers compelling combination of low mass and relatively small radiator areas
- Stirling minimum mass designs show preference for low mass rather than high efficiency converters
- Stirling study is a work-in-progress
  - Additional work in the following areas:
    - System Architecture
    - Power Management and Distribution with low frequency AC

**Glenn Research Center**



at Lewis Field