

# Thermodynamics of Titanium-Aluminum-Oxygen Alloys Studied

Titanium-aluminum alloys are promising intermediate-temperature alloys for possible compressor applications in gas-turbine engines. These materials are based on the  $\alpha_2$ -Ti<sub>3</sub>Al +  $\gamma$ -TiAl phases. The major issue with these materials is high oxygen solubility in  $\alpha_2$ -Ti<sub>3</sub>Al, and oxidation of unsaturated alloys generally leads to mixed nonprotective TiO<sub>2</sub>+Al<sub>2</sub>O<sub>3</sub> scales. From phase diagram studies, oxygen saturated  $\alpha_2$ -Ti<sub>3</sub>Al(O) is in equilibrium with Al<sub>2</sub>O<sub>3</sub> (ref. 1); however, oxygen dissolution has a detrimental effect on mechanical properties and cannot be accepted. To better understand the effect of oxygen dissolution, we examined the thermodynamics of titanium-aluminum-oxygen alloys.

A series of alloys near the  $\alpha_2$ -Ti<sub>3</sub>Al phase field of varying oxygen content were prepared. The study involved (1) determining the precise phase and composition of each alloy at temperature and (2) determining the thermodynamic activities of titanium, aluminum, and oxygen for each alloy. Compositional and phase analysis was done via standard chemical analysis, x-ray diffraction, and microprobe techniques.

Thermodynamic measurements were conducted with a vapor pressure technique, using a unique double-cell system designed and fabricated at the NASA Glenn Research Center (ref. 2). This is illustrated in the figure. The Knudsen cell technique has been used for many years to give precise vapor pressures. In this technique, vapor pressures of a particular component in an alloy and those in a pure material are measured. The ratio of the two vapor pressures is the thermodynamic activity.

For accurate measurements to be obtained, a number of critical issues must be addressed. Precise measurement and uniformity of temperature in the cells is essential. Temperatures were measured with thermocouples touching the sides of the cells. Mixing of the molecular beams from each cell proved to be a major issue, so alternative materials were used, with appropriate corrections for the cross sections. Copper was used in place of aluminum; nickel was used in place of titanium.

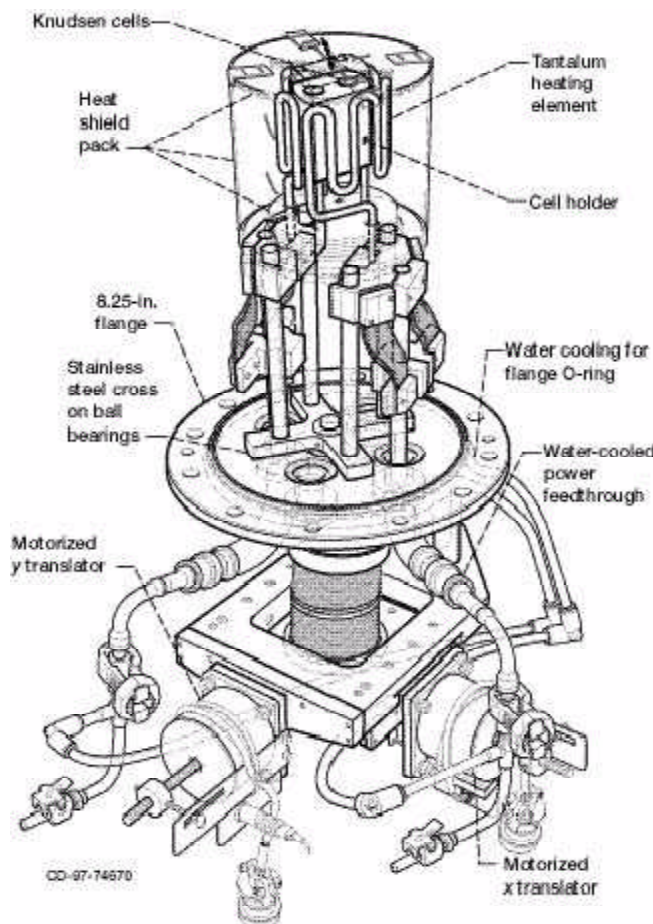

*Double Knudsen cell flange with furnace and x-y translation.*

In a mass spectrometer, vapor pressures  $P$  are related to intensity  $I$  by  $P = kI/\sigma$ . Here,  $k$  is the machine constant and  $\sigma$  is the ionization cross section. Initially, a second law heat was measured with the copper or nickel standard. Agreement with the tabulated values indicated that the temperature calibrations and ion intensity measurement system were functioning properly. From each standard data point, the quantity  $k/\sigma_{\text{Cu}}$  or  $k/\sigma_{\text{Ni}}$  was determined. The cross-section ratios  $\sigma_{\text{Cu}}/\sigma_{\text{Al}}$  and  $\sigma_{\text{Ni}}/\sigma_{\text{Ti}}$  were obtained from previous measurements of pure copper/pure aluminum and pure nickel/pure titanium. The standard provided a check of the system and an in situ value of  $k/\sigma_{\text{Al}}$  and  $k/\sigma_{\text{Ti}}$  that could then be used to calculate the vapor pressure of Al or Ti over the alloy.

Oxygen activities were measured from the  $\text{Al}_2\text{O}(\text{g}) = \frac{1}{2} \text{O}_2(\text{g}) + \text{Al}(\text{in alloy})$  equilibria (ref. 3). The equilibrium constant for this reaction is well known (ref. 3). The values for  $P(\text{Al}_2\text{O})$  and the activity of Al are measured and, hence,  $P(\text{O}_2)$  could be determined. Oxygen partial pressures in the range of  $10^{-30}$  can be reliably measured.

Initial measurements have been completed in the  $\beta\text{-Ti} + \alpha_2\text{-Ti}_3\text{Al}$  and  $\alpha_2\text{-Ti}_3\text{Al} + \gamma\text{-TiAl}$  two-phase fields. In the  $\beta\text{-Ti} + \alpha_2\text{-Ti}_3\text{Al}$  two-phase field, oxygen decreases the titanium activity and increases the aluminum activity. In the  $\alpha_2\text{-Ti}_3\text{Al} + \gamma\text{-TiAl}$  two-phase field, the activities of Al and Ti appear less dependent on oxygen. Further work is underway on

additional alloys in this system.

## References

1. Li, X.L., et al.: Reactions and Phase-Relations in the Ti-Al-O System. *Acta Metall. Mater.*, vol. 40, no. 11, 1992, pp. 3149-3157.
2. Jacobson, N.S.; Brady, M.P.; Mehrotra, G.M.: Thermodynamics of Selected Ti-Al and Ti-Al-Cr Alloys. *Oxid. Met.*, vol. 52, nos. 5-6, 1999, pp. 537-556.
3. Chase, Malcolm W., Jr.: NIST-JANAF Thermochemical Tables. Fourth ed., American Chemical Society, Washington, DC, 1998.

**Glenn contacts:** Dr. Evan H. Copland, 216-433-3738, [Evan.H.Copland@grc.nasa.gov](mailto:Evan.H.Copland@grc.nasa.gov);  
and Dr. Nathan S. Jacobson, 216-433-5498, [Nathan.S.Jacobson@grc.nasa.gov](mailto:Nathan.S.Jacobson@grc.nasa.gov)

**Authors:** Dr. Evan H. Copland and Dr. Nathan S. Jacobson

**Headquarters program office:** OAT

**Programs/Projects:** DDF