



# MIT-NASA Workshop: Transformational Technologies

*D.V. Smitherman, NASA Workshop Chair  
Marshall Space Flight Center, Marshall Space Flight Center, Alabama*

*J. Hoffman, MIT Workshop Chair  
Massachusetts Institute of Technology, Cambridge, Massachusetts*

*R. Patel, MIT Workshop Coordinator  
Massachusetts Institute of Technology, Cambridge, Massachusetts*

*J.C. Mankins, Proceedings Editor  
NASA Headquarters, Washington, DC*

*C.B. Christensen, E.C. Gresham, A. Simmons, and C.A. Mullins, Proceedings Authors  
The Tauri Group, Alexandria, Virginia*

Proceedings of a workshop sponsored  
by the National Aeronautics and Space  
Administration held in Cambridge, Massachusetts,  
December 11–12, 2003

## The NASA STI Program Office...in Profile

Since its founding, NASA has been dedicated to the advancement of aeronautics and space science. The NASA Scientific and Technical Information (STI) Program Office plays a key part in helping NASA maintain this important role.

The NASA STI Program Office is operated by Langley Research Center, the lead center for NASA's scientific and technical information. The NASA STI Program Office provides access to the NASA STI Database, the largest collection of aeronautical and space science STI in the world. The Program Office is also NASA's institutional mechanism for disseminating the results of its research and development activities. These results are published by NASA in the NASA STI Report Series, which includes the following report types:

- **TECHNICAL PUBLICATION.** Reports of completed research or a major significant phase of research that present the results of NASA programs and include extensive data or theoretical analysis. Includes compilations of significant scientific and technical data and information deemed to be of continuing reference value. NASA's counterpart of peer-reviewed formal professional papers but has less stringent limitations on manuscript length and extent of graphic presentations.
- **TECHNICAL MEMORANDUM.** Scientific and technical findings that are preliminary or of specialized interest, e.g., quick release reports, working papers, and bibliographies that contain minimal annotation. Does not contain extensive analysis.
- **CONTRACTOR REPORT.** Scientific and technical findings by NASA-sponsored contractors and grantees.

- **CONFERENCE PUBLICATION.** Collected papers from scientific and technical conferences, symposia, seminars, or other meetings sponsored or cosponsored by NASA.
- **SPECIAL PUBLICATION.** Scientific, technical, or historical information from NASA programs, projects, and mission, often concerned with subjects having substantial public interest.
- **TECHNICAL TRANSLATION.** English-language translations of foreign scientific and technical material pertinent to NASA's mission.

Specialized services that complement the STI Program Office's diverse offerings include creating custom thesauri, building customized databases, organizing and publishing research results...even providing videos.

For more information about the NASA STI Program Office, see the following:

- Access the NASA STI Program Home Page at <http://www.sti.nasa.gov>
- E-mail your question via the Internet to [help@sti.nasa.gov](mailto:help@sti.nasa.gov)
- Fax your question to the NASA Access Help Desk at 301-621-0134
- Telephone the NASA Access Help Desk at 301-621-0390
- Write to:  
NASA Access Help Desk  
NASA Center for AeroSpace Information  
7121 Standard Drive  
Hanover, MD 21076-1320  
301-621-0390



# MIT-NASA Workshop: Transformational Technologies

*D.V. Smitherman, NASA Workshop Chair  
Marshall Space Flight Center, Marshall Space Flight Center, Alabama*

*J. Hoffman, MIT Workshop Chair  
Massachusetts Institute of Technology, Cambridge, Massachusetts*

*R. Patel, MIT Workshop Coordinator  
Massachusetts Institute of Technology, Cambridge, Massachusetts*

*J.C. Mankins, Proceedings Editor  
NASA Headquarters, Washington, DC*

*C.B. Christensen, E.C. Gresham, A. Simmons, and C.A. Mullins, Proceedings Authors  
The Tauri Group, Alexandria, Virginia*

Proceedings of a workshop sponsored  
by the National Aeronautics and Space  
Administration held in Cambridge, Massachusetts,  
December 11–12, 2003

National Aeronautics and  
Space Administration

Marshall Space Flight Center • MSFC, Alabama 35812

Available from:

NASA Center for Aerospace Information  
7121 Standard Drive  
Hanover, MD 21076-1320  
301-621-0390

National Technical Information Service  
5285 Port Royal Road  
Springfield, VA 22161  
703-487-4650

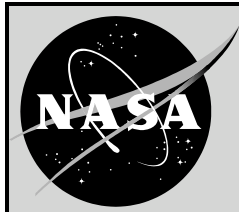

## Executive Summary



At this critical turning point in the evolution of space exploration, NASA is finding innovative ways to achieve ambitious exploration goals. Through a series of workshops, NASA is collecting concepts that will help it to incorporate the latest technologies into affordable, reliable, effective and flexible space architectures.

This report describes the NASA Workshop on Transformational Technologies, held at the Massachusetts Institute of Technology (MIT) on December 11-12, 2003. The workshop featured two-dozen world-class experts presenting leading-edge technologies and applications in four areas: power and propulsion; communications; automation, robotics, computing, and intelligent systems; and transformational techniques for space activities. Research areas, methodologies, objectives, and findings varied widely, but speakers also spoke to common themes. In particular, the workshop yielded insight into four cross-discipline research and technology development strategies for space capabilities. They were: design a flexible architecture; ensure that it incorporates and reaps the benefits of modularity and reusability as design approaches; invest in energy-efficient space systems; and, learn to apply design and operations drawn from models found in nature.

This workshop—held just prior to the announcement of the new Vision for Space Exploration—contributed to NASA’s ongoing quest to transform space exploration through innovation and the thoughtful application of new and evolving technologies and processes. NASA plans to continue conducting exploration technology-focused workshops and technical interchange meetings to capture the broadest possible array of insights and expertise, learning from researchers in universities, national laboratories, NASA field centers, and industry to help better our future in space.

| Presentations on Power and Propulsion             |  |   |
|---|--|---|
| Advanced Nuclear Technology for Space Exploration | Andrew Kadak and Peter Yarsky, Department of Nuclear Engineering, MIT    | Goal is to create nuclear power options that are reusable and scalable to meet a range of mission power needs.  |
| Nuclear Technology for Project Prometheus         | Carl Walz, Office of Space Science, NASA Headquarters                    | The objective of Project Prometheus is to advance space nuclear electric power to enable new classes of space exploration missions not possible using current power and propulsion systems.                                 |
| MEMS-Based Bipropellant Liquid Rocket Engines     | Stu Jacobson, Department of Aeronautics and Astronautics, MIT            | Program to create a low-cost, microfabricated bipropellant rocket engine with a large thrust-to-weight (1000 to 1) ratio suitable for small payloads, such as microsattellites for Earth observation.                       |
| Laser Propulsion Systems                          | Oleg Batishchev, Dep't. of Nuclear Engineering, MIT                      | Laser ablation and radio frequency-driven plasma sources offer favorable scaling and other benefits for space mission needs.  |
| Advanced Plasma Propulsion                        | Manuel Martinez-Sanchez, Department of Aeronautics and Astronautics, MIT | Through modeling and experimentation, this team is finding ways to improve propulsion efficiency, while making thrusters more compact and robust. Research areas include liquid-based ion propulsion and Hall-type ramjets. |
| Electromagnetic Formation Flight                  | Raymond Sedwick, Department of Aeronautics and Astronautics, MIT         | This team has proposed a system for propulsion applications using three orthogonal electromagnetic coils that would allow the magnetic dipole to be created in any direction.   |
| Electric Propulsion Testbed on the ISS            | Lee Morin, Astronaut Office, NASA Johnson Space Center                   | This project proposes using the International Space Station as an orbiting test facility to demonstrate advanced power, power storage, and propulsion concepts in a real space environment.                                 |

| <b>Presentations on Communications Systems</b>  |  |   |
|---|--|---|
| New Space Communications Architectures  | Vincent Chan, Department of Aeronautics and Astronautics, MIT        | Research into using optical crosslinks in a space communications architecture to dramatically increase capacity and reduce costs compared to current systems.   |
| Alternative Concepts for Communications   | Joel Schindall, Laboratory for Information and Decision Systems, MIT | Approaches to improve LEO communications, such as using commercial satellites to relay data; launching improved processors to orbit near LEO satellites; and, launching fuel separately.  |
| Communications Technologies for Space   | Participant discussion   | Workshop attendees discussed future communications systems and technologies for a range of multi-disciplinary applications.   |
| <b>Automation, Robotics, Computing, and Intelligent Systems</b>                           |  |   |
| Robust Autonomous Systems that are Self Aware   | Brian Williams, Model-based Embedded and Robotic Systems Group, MIT  | Project to create embedded program languages that avoid common-sense mistakes (e.g., those that caused failure of the Mars Polar Lander, Climate Orbiter) by reasoning from hardware models.  |
| Next Generation On-Orbit, Surface, and Subsurface Robotic Systems                         | Karl Iagnemma, Department of Mechanical Engineering, MIT             | Research into next generation robotics with increased mobility and articulation, and ability to work cooperatively, sharing data and performing tasks that are beyond an individual robot or human.   |
| Micro Chemical and Thermal Systems (MicroCATS)  | Robert Wegeng, Pacific Northwest National Laboratory                 | The MicroCATS modular chemical processing chip consists of four cells each of microreactors and heat exchangers. The goal is to miniaturize systems for rapid heat and mass transfer, making them modular, smaller, and lighter weight.                               |
| Collective Vision for Optical Technology  | George Barbastathis, Department of Mechanical Engineering, MIT       | Research into volume holograms, which are created by interfering at least two optical beams over the volume of a photo-sensitive material and used for 3-D imaging.   |
| Modular Stability Tools for Distributed Computation and Control                           | Jean-Jacques Slotine, Department of Mechanical Engineering, MIT      | Research examines swarming behavior, such as schools of fish where individuals synchronize, and asks how to get consistent behavior from groups using only local, non-linear interactions   |
| <b>Transformational Techniques for Space Activities</b>                                   |  |   |
| Why Cutting Paths are Different from Robotic Paths: Sensor and Navigation                 | Sanjay Sarma, Mechanical Engineering, MIT                            | New approaches to computer-aided manufacturing (focusing on cutting path challenges), such as low-cost radio frequency identification (RFID) tags, networking and sensing, mesh networking, data management, and inferencing.   |
| Tubular Structures  | Lorna Gibson, Department of Materials Science and Engineering, MIT   | Research on biomimicking the design of tubular structures (such as tubes with honeycombs or foams as core materials), with the potential for stiffened tubular structures at smaller scales.  |
| Avogadro-Scale Engineering  | Neil Gershenfeld, Center for Bits and Atoms, MIT                     | Current fabrication methods are orders of magnitude away from the limits governing how molecules can be ordered. The goal of Avogadro-scale engineering is to design and build affordable, practical systems that are at the boundary of complexity and scale.        |
| Staged Development of Complex Systems   | Olivier de Weck, Space Systems Laboratory, MIT                       | Research into how space systems architects should optimize the evolution path of systems, rather than develop rigid point designs.  |
| Extensibility in Space Transportation   | Ed Crawley, Department of Aeronautics and Astronautics, MIT          | Research into extensibility of space systems and architectures. Extensibility, the ability to add new elements to a system in a way that alters the value delivered, offers a reduction of overall life cycle cost, due to reuse, commonality, and ease of learning.  |
| Modular Reusable Space Architecture   | Jim Geffre, Advanced Development Office, NASA Johnson Space Center   | Research into modular, reusable space architectures that will enable robust, routine transportation of people and payloads to and from low Earth orbit and higher energy orbits.  |
| Lean Aerospace Initiative   | Terry Bryan, LAI   | The Lean Aerospace Initiative works to help aerospace firms draw on and benefit from the best practices of other industries.  |
| Advanced Systems and Safety Engineering Environments                                      | Nancy Leveson, Department of Aeronautics and Astronautics, MIT       | SpecTRM (Specification Tools and Requirements Methodology) is a system engineering toolset that can be used to design component-based system architectures that reuse system engineering artifacts, reuse design rationale, validate requirements, and reduce errors. |
| Using the ISS as an Engineering Technology Research Laboratory for Space-Based Telescopes | Dave Miller, Space Systems Laboratory, MIT                           | Research into using the International Space Station as a technology development laboratory for space-based telescopes and related technologies and systems.   |

## TABLE OF CONTENTS

|  |    |
|--|----|
| INTRODUCTION .....   | 1  |
| WORKSHOP RESULTS: RESEARCH AND TECHNOLOGY DEVELOPMENT STRATEGIES .....               | 3  |
| PRESENTATION TOPIC 1: POWER AND PROPULSION .....                                     | 7  |
| Space Nuclear Power Options .....  | 8  |
| Nuclear Technology for Project Prometheus .....                                      | 9  |
| MEMS-based Bipropellant Liquid Rocket Engines .....                                  | 10 |
| Ultrafast Laser Ablation and RF-Driven Plasma for Space Propulsion .....             | 11 |
| Advanced Space Propulsion .....  | 12 |
| Electromagnetic Formation Flight .....   | 13 |
| Electric Propulsion Testbed on the ISS .....   | 14 |
| PRESENTATION TOPIC 2: COMMUNICATIONS SYSTEMS .....                                   | 15 |
| New Space Communications Architectures .....   | 16 |
| Alternative Concepts for Communications .....  | 17 |
| Communications Technologies for Space Applications .....                             | 18 |
| PRESENTATION TOPIC 3: AUTOMATION, ROBOTICS, COMPUTING, AND INTELLIGENT SYSTEMS ..... | 19 |
| Robust Autonomous Systems that are Self Aware .....                                  | 20 |
| Next Generation On-Orbit, Surface, and Subsurface Robotic Systems .....              | 21 |
| Micro-Chemical and Thermal Systems (MicroCATS) .....                                 | 22 |
| Collective Vision for Optical Technology .....                                       | 23 |
| Modular Stability Tools for Distributed Computation and Control .....                | 24 |
| PRESENTATION TOPIC 4: TRANSFORMATIONAL TECHNIQUES FOR SPACE ACTIVITIES .....         | 25 |
| Why Cutting Paths are Different from Robotic Paths .....                             | 26 |
| Tubular Structures .....   | 27 |
| Avogadro-Scale Engineering .....   | 28 |
| Staged Deployment of Complex Systems .....   | 29 |
| Extensibility in Space Transportation .....  | 30 |
| Modular Reusable Space Architecture .....  | 31 |

## TABLE OF CONTENTS (Continued)

|  |    |
|--|----|
| Lean Aerospace Initiative (LAI) .....  | 32 |
| Advanced System and Safety Engineering Environments .....  | 33 |
| Using the International Space Station as an Engineering Technology Research<br>Laboratory for Space Based Telescopes ..... | 34 |
| NEXT STEPS .....   | 35 |
| APPENDIX A: LIST OF ATTENDEES .....  | 36 |



## CONFERENCE PUBLICATION

### MIT-NASA WORKSHOP: TRANSFORMATIONAL TECHNOLOGIES

## Introduction

We are at a critical turning point in the evolution of space exploration. NASA has demonstrated through the International Space Station its ability to maintain a human outpost in orbit. The Agency has announced its Vision for Space Exploration, a vision of returning humans to the Moon, sending robots and eventually humans to Mars, and exploring the outer solar system via automated spacecraft. New space telescopes will reveal the secrets of our galaxy and provide insights into our origins. Mission concepts have become increasingly complex, with the potential to yield a wealth of scientific knowledge.

At the same time, there are significant resource challenges to be met. Launch costs remain a barrier to routine space flight. The ever-changing fiscal and political environments—where a program may receive funding this year only to have its budget slashed five years down the road—can wreak havoc on mission planning. Technologies are constantly improving, and systems that were state of the art when a program began can quickly become outmoded before a mission is even launched. However, redesigning the space architecture midcourse to incorporate technological advancements is time consuming and expensive.

NASA has taken a synergistic approach to finding innovative ways to achieve its ambitious goals with constrained resources. Through a series of workshops, NASA is collecting concepts that will help it define and implement new strategies for incorporating the latest technologies into affordable, reliable, effective and flexible space architectures. This report describes the Workshop on Transformational Technologies, held at the Massachusetts Institute of Technology (MIT) on December 11-12, 2003.

The workshop at MIT—held just prior to the announcement of the new Vision—featured presentations on leading-edge technologies and applications in the areas of power and propulsion; communications; automation, robotics, computing, and intelligent systems; and transformational techniques for space activities. Investigators from MIT, NASA, and other public and private laboratories described their research and its potential value to NASA. Their presentations are summarized here. (A group discussion on the wide-ranging impacts of communications technologies is also summarized, using the same format.) The summaries, grouped by technology area, highlight the benefits and innovations of the research projects and describe anticipated future activities. The summaries also provide contact information for each presenter.

As the world-class experts at the workshop spoke about their work, four cross-discipline research and technology development strategies for space capabilities emerged:

- Design a flexible architecture.
- Reap the benefits of modularity and reusability.
- Invest in energy-efficient systems.
- Learn from models found in nature.

Each of these powerful strategies is described in the Workshop Results: Research and Technology Development Strategies section of this report.

| <b>WORKSHOP PRESENTATIONS</b>   |
|---|
| <b>Power and Propulsion</b>   |
| Advanced Nuclear Technology for Space Exploration   |
| Nuclear Technology for Project Prometheus   |
| MEMS-Based Bipropellant Liquid Rocket Engines   |
| Laser Propulsion Systems  |
| Advanced Plasma Propulsion  |
| Electromagnetic Formation Flight  |
| Electric Propulsion Testbed on the ISS  |
| <b>Automation, Robotics, Computing, and Intelligent Systems</b>   |
| Robust Autonomous Systems that are Self Aware   |
| Next Generation On-Orbit, Surface, and Subsurface Robotic Systems   |
| Micro Chemical and Thermal Systems (MicroCATS)  |
| Collective Vision for Optical Technology  |
| Modular Stability Tools for Distributed Computation and Control   |
| <b>Communications Systems</b>   |
| New Space Communications Architectures  |
| Alternative Concepts for Communications   |
| Communications Technologies for Space Applications  |
| <b>Transformational Techniques for Space Activities</b>   |
| Why Cutting Paths are Different from Robotic Paths: Sensor and Navigation   |
| Tubular Structures  |
| Avogadro-Scale Engineering  |
| Staged Development of Complex Systems   |
| Extensibility in Space Transportation   |
| Modular Reusable Space Architecture   |
| Lean Aerospace Initiative   |
| Advanced Systems and Safety Engineering Environments  |
| Using the International Space Station as an Engineering Technology Research Laboratory for Space-Based Telescopes |



# Workshop Results: Research and Technology Development Strategies

At the December, 2003 NASA workshop held at MIT, two dozen researchers spoke about their work in diverse science, engineering, and technology arenas. Their methodologies, objectives, and findings varied widely, but many touched on common themes. In particular, the workshop yielded insight into four cross-discipline research and technology development strategies for space capabilities. They were: design a flexible architecture; ensure that it incorporates and reaps the benefits of modularity; invest in energy-efficient space systems; and, learn from models found in nature.

## Flexible Architectures

Mission planning and development requires the ability to select and apply the proper technology. Technologies often become obsolete during development, forcing the mission planner to decide whether the benefits of an upgrade outweigh the cost and impact on scheduling. Changing technologies after the planning phase is completed can be prohibitively difficult and expensive if the system was not designed to accommodate changes. This is exacerbated by the fact that many missions rely on unique systems that are not shared by other missions. There are no “lessons learned” from other missions that can help speed implementation. NASA is seeking better approaches to system and mission architecture that would enable it to use new technologies in smart ways.



Workshop presentations outlined strategies for achieving the goal of flexible architectures. Two presentations provided conceptual approaches for enterprise-level design to accommodate change and uncertainty. Oliver de Weck discussed the benefits of staged deployment of complex systems. Ed Crawley provided a theoretical framework for extensible systems that incorporate agility, adaptability, and robustness.

Many presentations addressed the importance of commonsense approaches to design and development, especially learning the lessons of the past and leveraging resources creatively. Nancy Leveson described knowledge capture and systems engineering tools for avoiding common-sense mistakes such as those that caused the failure of the Mars Polar Lander. The Lean Aerospace Initiative (LAI) was described at the workshop by Terry Bryan; it has a successful track record of applying the best practices of other industries to aerospace firms. Four presentations thoughtfully described new and valuable uses for the International Space Station and for existing on-orbit LEO satellite systems, which represent billions of dollars in investment. Both Lee Morin and Dave Miller laid out methods for using the International Space Station as a technology development laboratory for technologies and systems ranging from propulsion to space-based telescopes.

Vincent Chan described how commercial, space-proven technology for optical crosslinks could dramatically increase the capacity and reduce the costs of space-based communication systems for data transfer from exploration missions. (George Barbastathis described his research on 3-dimensional volume holograms, advanced optical technology that could be used for extremely high speed networking data communications, as well as imaging and data storage.) Joel Schindall offered several approaches to using LEO communications satellites for data relay, and also for increasing satellite processing power and lifetimes.

## Modularity

Modularity is not a new concept. It helped fuel the industrial revolution, making a range of technologies affordable and practical. But modularity has not been widely used by the space community. Traditional space programs have relied heavily on custom-constructed, mission-specific systems that use few common interfaces or subsystem elements. Conversely, modular systems use standardized, mass-produceable, and reusable parts that can be applied to a range of projects, reconfigured to meet evolving demand, and swapped out or reused as needed.

Many workshop presentations reflected the value of modularity as a life-cycle strategy to improve design, production, architecture flexibility, operation, and maintenance. A frequently referenced example of the demonstrated benefits of a modular approach was the manufacturing economies of scale achieved with the Iridium and Globalstar LEO satellite systems. Modular elements were shown to be important to achieving staged deployment and extensible architectures.

Two visionary presentations illustrated the potential benefits of modularity to space systems – one at the architecture level, the other with components the size of a pinhead.

Jim Geffre described innovative space systems for the future, such as a lunar elevator, a solar electric propulsion tug, and a propellant depot, with a twist. Many diverse system elements were modularized, including propulsion systems, thrusters, engines, avionics, life support systems, photovoltaic arrays, common busses, cryogenic storage, and fluid transfer systems.

Neil Gershenfeld spoke about the potential of Avogadro-scale engineering, which could enable technologies, from computers to spacecraft systems, to be greatly reduced in size—possibly to molecular scale. Avogadro-scale engineering is still at the conceptual and research phase, and it is difficult to tell just how it will affect future technologies, but researchers hope that it could make it possible to take microfabrication to a new scale. One of the compelling concepts presented was that of a “paintable” computer, consisting of thousands of tiny processors, program memory elements, and wireless transceivers randomly deposited in a viscous medium. When powered, these elements would communicate with their neighbors in the fluid, boot, and self-assemble to form a computer. This paintable computer could conceivably be added to surfaces, such as building materials or paper, to make them smarter.

### **Energy Efficient Space Systems**

NASA’s new, ambitious exploration roadmap will depend on next-generation propulsion and power systems that are robust, efficient, and can operate in the extremely low temperatures found in the outer solar system. All space missions require a source of power, and these technologies provide scalable and relatively small and lightweight designs which are more easily incorporated into innovative modular space architectures.

Modular microrockets, explained in Stu Jacobson’s presentation, offer good thrust and specific impulse in a small package. Using a traditional bipropellant mixture, these thrusters are arrayable and can be used for a range of mission sizes. They are small and lightweight, so more of the vehicle mass can be dedicated to payload or vital systems, and they can be batch manufactured, supporting NASA’s goal of achieving low-cost access to space. Andrew Kadak and Peter Yarsky presented on innovative nuclear power options that are scalable and reusable that could meet a variety of exploration mission requirements.

Propulsion needs can severely limit mission goals. Propellant is a limited resource that can run out before other systems reach their end of life. It is impractical, however, to greatly increase the amount of propellant a vehicle carries because it would add mass that would, in turn, inflate launch costs. Instead, NASA is focusing on fuel efficiency. Project Prometheus, a program designed to produce technologies that will enable missions to several targets in the outer solar system, is focusing on nuclear power sources and several conversion strategies. Carl Walz addressed new power capabilities that, when matured, will yield significantly increased power compared with current systems. Future missions will be able to change targets mid-mission, orbit multiple objects, and change speed, while also providing more power to science instruments. The Jupiter Icy Moons Orbiter, the first anticipated Prometheus mission, will be able to return an estimated 50,000 gigabits of data, as compared to the less than 100 gigabits returned by Cassini. In Raymond Sedwick’s presentation on electromagnetic formation flight, he describes an advanced propulsion concept that uses magnetic forces to electrically steer spacecraft, which provides efficient propulsion and eliminates the need for chemical propellant on long duration missions.

Two examples of next-generation propulsion systems explained in Oleg Batishchev’s presentation include laser ablation which provides low power but an “infinite” lifetime, and radio-frequency plasma sources, which yield 100 percent gas propellant ionization at low cost. Manuel Martinez-Sanchez presented two concepts that are likely to improve propulsion efficiency while enabling compact and robust systems: liquid-based ion propulsion, and Hall-type ramjet thrusters. Finally, Lee Morin’s presentation described how using the International Space Station as a testbed could be an integral step in proving new propulsion concepts.

### **Models from Nature**

Researchers are increasingly turning to nature for solutions to the complex issues that occur when developing cross-cutting technologies for space exploration missions. Structures, robotic systems, and network architectures are just a few examples of development areas where biologically-inspired technologies are being researched and implemented.

Traditionally, large-scale tubes, like those that form a space vehicle fuselage, are stiffened via a system of longitudinal and circumferential braces that add weight to the overall structure. Porcupine quills and grassy stems achieve good stiffness at a smaller scale through a porous core surrounded by a thin, hard outer shell. Lorna Gibson presented on research being conducted at MIT, exploring ways to translate this to large-scale engineering tubes. The result would be tubes that resist buckling, are lightweight (a plus when it comes to launch), and require fewer individual elements (e.g., cross braces), making them easier to construct and less expensive.

Future space exploration will use robotics that are far more advanced than the recent Mars exploration rovers, whose designs are inspired by organisms. Karl Iagnemma presented research on the use of robots that can hop, clamber over difficult terrain, or tunnel under the surface, and robots that when networked into a team, can perform individual tasks but share information that allows them to perform their tasks smarter and more efficiently.

Every creature is a complex of chemical reactions and neural signals that coordinate cells, tissues, systems, and limbs into an orchestrated whole. Robert Wegeng presented on researchers placing new emphasis on microfabricated mini-elements that are standardized and can be configured and reconfigured to form micro chemical and thermal systems (MicroCATS), similar to the way that individual organs form the cardiopulmonary system. The systems are organized by computerized neural nets that can grow, adapt, and quickly reason through unexpected occurrences much as the human mind does. The goal is to provide vehicles, whether large spacecrafts or small robots, with fine degrees of control and the capability to avoid problems that have hampered missions in the past. Jean-Jacque Slotine described research in the field of non-linear dynamics that attempts to mimic swarming behavior, providing tools to synchronize multiple elements around a leader, such as robotic legs with a control system, or managing a group through a network, such as several microbots serving a single mission. Brian Williams' presentation on self-aware systems described a design project that would enable robotic systems to make autonomous decisions based on "reason," potentially reducing the demand for constant human interaction with robotic systems in exploration decision making. Sanjay Sarma described research into robotic decision-making for mapping paths, giving as an example a cutting tool analog called the termine, which plans its path based on three types of areas: free space, soft obstacles, and hard obstacles. It chews through soft obstacles, creating a free space through which it can haul its body.



## Presentation Topic 1: Power and Propulsion

Power and propulsion systems can make or break a mission architecture. Mission destination, length, scientific return, payload (including the number of crew for human missions) and life-cycle cost are intimately linked to the speed, strength, and efficiency of power and propulsion options. The 2004 *Vision for Space Exploration* has outlined goals—returning astronauts to the Moon, sending automated spacecraft to explore the outer solar system, and eventually sending humans to Mars—that cannot be achieved, either technically or economically, using traditional power and propulsion systems.

Moreover, a range of new power and propulsion technologies is needed for different exploration scenarios. Options that can be applied to a robotic mission to Jupiter’s moons, where speed could be reduced in favor of high power and long life, could not be applied to a crewed mission to Mars, where speed and propellant/power efficiency are critical to reducing vehicle mass while maintaining crew health and productivity. New power and propulsion systems that NASA is exploring include improved versions of existing systems, such as nuclear power systems, and systems that are based on cutting-edge technologies, such as radio-frequency-driven plasma used for in-space propulsion. Many of these systems are quite small, taking advantage of the latest techniques for microfabrication, while remaining comparable to or better than today’s larger-sized systems.

The one characteristic that applies to all the power and propulsion systems that will enable the new exploration roadmap, however, is modularity. Next-generation space technologies are being designed so that they can be applied to many systems across multiple projects and programs, are reusable, can be upgraded or replaced more easily than current technologies, and can be mass produced. Modularity is a life-cycle strategy that can improve design, production, mission flexibility, operation, and maintenance, while also lowering costs over the life of a program.

The following presentations on innovative technologies address NASA’s needs for increased capabilities, affordability, and flexibility in power and propulsion.

| Power and Propulsion Presentations                |                              |
|---|------------------------------|
| Advanced Nuclear Technology for Space Exploration | Andrew Kadak, MIT            |
| Nuclear Technology for Project Prometheus         | Carl Walz, NASA              |
| MEMS-Based Bipropellant Liquid Rocket Engines     | Stu Jacobson, NASA           |
| Laser Propulsion Systems                          | Oleg Batishchev, MIT         |
| Advanced Plasma Propulsion                        | Manuel Martinez-Sanchez, MIT |
| Electromagnetic Formation Flight                  | Raymond Sedwick, MIT         |
| Electric Propulsion Testbed on the ISS            | Lee Morin, NASA              |

## Space Nuclear Power Options

Andrew Kadak and Peter Yarsky, Department of Nuclear Engineering, MIT

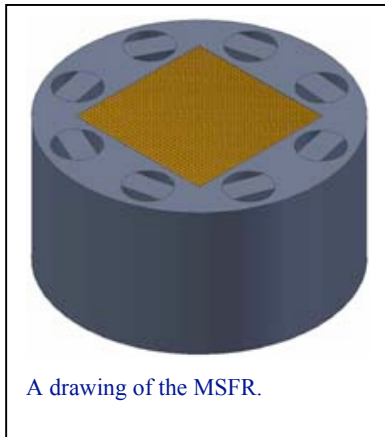

The goal of MIT's work is to create nuclear power options that are reusable and scalable to meet a range of mission power needs. The Ultra High Power Density Core (UHPDC) uses reactor grade plutonium—the most reactive fuel in fast spectrum, yielding vast amounts of power at low mass—to produce thermal power that would then be converted by a static (thermophotovoltaics or thermionics) or dynamic (Brayton or Rankine) converter.

The first concept, the Molten Salt Fast Reactor (MSFR), combines the UHPDC with molten salt coolant and thermophotovoltaic (TPV) conversion cells, a robust converter with no moving parts and up to 40 percent efficiency at low temperatures. This system would produce an estimated 200 kW electric power for a robotic precursor Mars mission and around 4,000 kW for a human mission. It could then be incorporated into surface operations, where it would be cooled by the Martian atmosphere and shielded by the Martian soil and rock.

### Benefits and Innovations

- The major benefit of this space nuclear power is its scalability, which would ultimately reduce cost over the life of a mission. This power source would have a low launch mass (approximately 3 kilograms per kilowatt of power) and would yield more power for science instruments than currently used power sources. It would then evolve to meet the power demands of a Mars base (life support and in situ surface utilization), increasing surface stay time.
- The space nuclear power source is designed to be reusable. The reactor for a Mars Transfer System would be refueled after multiple transfers—up to three 180-day round trips at full power. The modular design would allow crew to replace individual components as needed.

### Status and Future Research/Developments

- Work is still in progress.

### Contact

Andrew Kadak, Department of Nuclear Engineering, Room 24-202, MIT, 77 Massachusetts Avenue, Cambridge, MA 02139-4307, phone 617-253-0166, fax 617-258-8863, kadak@mit.edu.



## Nuclear Technology for Project Prometheus

Carl Walz, Office of Space Science, NASA Headquarters

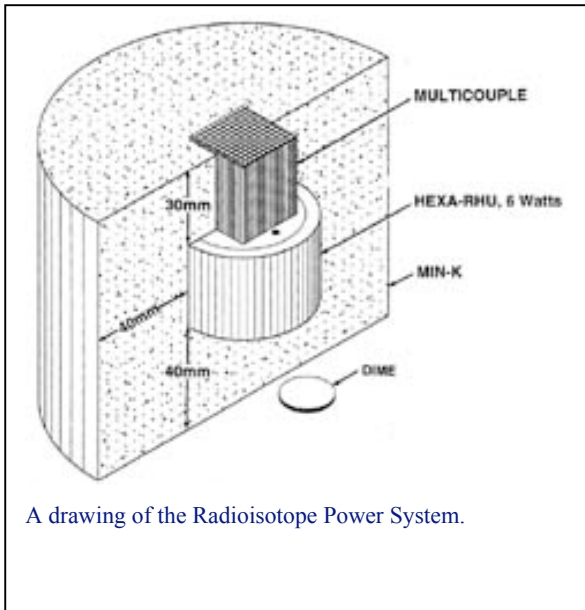

A drawing of the Radioisotope Power System.

The objective of Project Prometheus is to advance space nuclear electric power to enable new classes of space exploration missions not possible using current power and propulsion systems. Supporting NASA's goal to explore Mars and the outer solar system, Prometheus will yield reliable, long-lived, rugged power sources using radioisotope and fission reactor power systems. NASA is pursuing nuclear electric propulsion for both robotic and human space exploration, where it will be key for complex, long-duration missions beyond Earth orbit. It is also being developed for Mars habitation and life support.

Missions requiring low power over a long duration, such as the New Horizons mission to Pluto-Charon, a radioisotope power system would be used. Large, flagship missions, such as the Jupiter Icy Moons Orbiter (JIMO), would use a nuclear fission reactor. For both, thermal energy is converted to electricity (using a Brayton, Stirling, Rankine, Thermoelectric, or Thermophotovoltaic converter) for use by an electric propulsion system, scientific instruments, and communication systems.

### Benefits and Innovations

- No launch period constraints—the nuclear electric propulsion system is not dependent on gravitational assist, allowing the mission to be launched at any time.
- Greater ability to change speeds after launch.
- Ability to enter into orbit around multiple solar system bodies (current propulsion is limited to flyby observations)
- Ability to change target mid-mission.
- Much greater power (practically unlimited) available for instruments and communication, significantly increasing scientific yield. The most recent outer solar system mission, Cassini, only had approximately 300 Watts available for its instruments. JIMO will have tens of kilowatts available for instruments, increasing data return from less than 100 gigabits (Cassini) to up to 50,000 gigabits.
- High-efficiency propellant utilization.

### Status and Future Research/Developments

- NASA has partnered with the Department of Energy (including ORNL, LANL, and SNL) to conduct fission reactor research and develop radioisotope power systems.
- NASA has awarded three power conversion research grants and has selected three electric propulsion NASA Research Announcements, two of which have been awarded.
- JIMO mission design, technology development, and payload selection are in progress.

### Contact

Carl Walz, Code S, NASA Headquarters, 300 E Street, SW, Washington, DC 20546, phone 202-358-0357, carl.walz-1@nasa.gov.

## MEMS-based Bipropellant Liquid Rocket Engines

Stu Jacobson, Department of Aeronautics and Astronautics, MIT

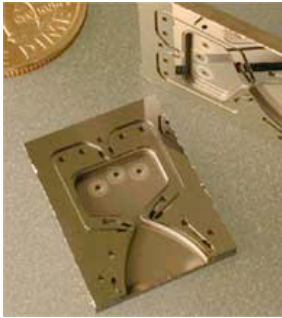

A microrocket engine is not much larger than a dime (upper left).

The goal of this program is to create a low-cost, microfabricated bipropellant rocket engine with a large thrust-to-weight (1000 to 1) ratio. Arrays of these rockets can be used to provide a wide range of thrust levels suitable for both small and large payloads. Applications include launch (ballistic and space) and orbit transfer. This rocket is currently designed to operate with JP7 (fuel) and hydrogen peroxide (oxidizer). The current rocket design is about the size of a stack of several dimes and will provide 15 N (3.3 lbs) of thrust with an  $I_{sp}$  of 290 sec.

These tiny engines are micro-machined from silicon wafers that are diffusion bonded to create a complete unit. Devices developed in this program using MEMS technology include combustion chambers and nozzles, turbopumps, and valves. In addition, we have explored a bipropellant auxiliary power unit for space applications that could be fabricated using this technology. This team is also currently developing a microfabricated gas turbine generator for land-based portable power applications.

### Benefits and Innovations

- Micro-electro-mechanical systems, or MEMS, are the integration of mechanical and electrical elements at the microscale, generally using silicon microfabrication technology. This team has shown that silicon is a robust material for this type of application and that microfabrication processing technology provides a level of precision suitable for these types of devices.
- This microrocket will have a very large (1000:1) thrust-to-weight ratio. In general, reducing the size of a rocket will result in an increase in thrust-to-weight ratio, so long as component efficiency levels can be maintained. Thus, an array of small rockets will provide better thrust-to-weight, at a given thrust level, than a single larger rocket.
- The microrocket offers the potential for commoditizing thrust. These modular microrocket engines can be arrayed to produce the necessary thrust for a given payload. Thus one design is applicable to a wide range of missions. Using batch processing, microfabrication techniques, the rockets can be produced at relatively low cost. One can then think of cost per mission rather than cost per payload pound, completely revolutionizing the economics and reducing the cost of payload delivery.
- The microrocket will create approximately 3 pounds of thrust and have a good  $I_{sp}$  of approximately 290 seconds.
- A packaging technique for making high temperature and high pressure fluidic connections to silicon devices has been developed.

### Status and Future Research/Developments

- This project was supported by NASA, the initial investor. Current support comes from the Defense Advanced Research Projects Agency/Department of Defense, through the end of 2003.
- The team is assessing the possibility of replacing the silicon wafers, which can only handle temperatures up to about 600 °C, with ceramic wafers, which require less cooling. Silicon was chosen initially because the machining techniques for this material are well established.

### Contact

Stuart Jacobson, Gas Turbine Laboratory, Microengine Project, Room 31-269, MIT, 77 Massachusetts Avenue, Cambridge, MA 02139, phone 617-253-2418, sjacob@mit.edu.

# Ultrafast Laser Ablation and RF-Driven Plasma for Space Propulsion

Oleg Batishchev, Department of Nuclear Engineering, MIT

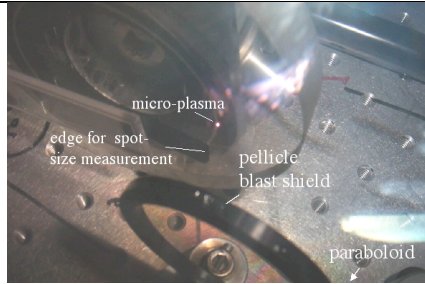
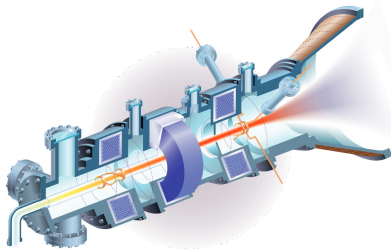

Photo of ultrafast laser ablation experiment hardware.



A drawing of VASIMR, which uses an RF plasma source and an IRCH plasma booster.

Laser ablation and radio frequency (RF)-driven plasma sources offer favorable scaling and other benefits.

Laser ablation provides low average power and an “infinite” lifetime. By reducing the time of the energy release (pulsed power), the power rises instantaneously, offering new ways to produce thrust. Possible laser ablation schemes include the laser insulated from the plume, a U-shaped magnetic nozzle (which might be the most reasonable design for small power levels with least amount of energy loss), and propellant-less solar-powered asteroid mining and deflecting.

The RF-driven system uses an “overdriven” helicon plasma source. The wall of the vacuum chamber is insulated with magnets to reduce the thermal load. The RF helicon antenna is evacuated from the plasma to increase longevity of the antenna. The low ionization cost and high ionization fraction yields efficiency.

## Benefits and Innovations

- Both laser ablation and RF-driven plasma space propulsion offer favorable scaling to meet a variety of mission needs.
- Using a solid propellant, laser ablation achieves an  $I_{sp}$  of between 1-100 Ksec. Testing, using ultrafast laser ablation (1  $\mu$ m focal spot, 1 mJ laser pulsed at 10 KHz), produced a thrust velocity of approximately 300 m/sec. An unoptimized laser yielded 10 percent efficiency.
- RF-driven plasma sources offer 100 percent gas propellant ionization at low cost, and they are electrodeless, increasing lifetime. Tests of a helicon thruster produced propellant efficiency (cold gas to hot plasma conversion) of more than 90 percent. The energy efficiency (gas ionization and plasma heating versus heat and radiative losses) was more than 80 percent. It produced several Newtons of thrust and approximately 5-7  $I_{sp}$ , with a thrust efficiency (beam energy to applied electrical energy) of more than 50 percent.

## Status and Future Research/Developments

- The goal for laser ablation sources is in faster energy release, and therefore higher densities and smaller focal points. The current system, which yields low efficiency, was designed for research purposes. Efficiency can be improved.

## Contact

Oleg Batishchev, Department of Nuclear Engineering, Room NW16-232, MIT, 77 Massachusetts Avenue, Cambridge, MA 02139-4307, phone 617-253-5799, fax 617-253-5805, batish@mit.edu.

## Advanced Space Propulsion

Manuel Martinez-Sanchez, Department of Aeronautics and Astronautics, MIT

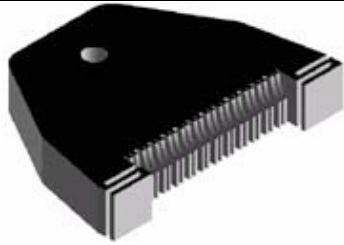

A drawing of a microfabricated colloid array.



A Hall thruster.

### Liquid-based Ion Propulsion:

Classical plasma ion engines and colloid thrusters present manufacturing challenges: ion engines are not modular and are difficult to miniaturize, while colloid thrusters are difficult to fabricate. Advances in ionic liquids, which are highly conductive and yield pure ion extraction, offer solutions to these challenges. These liquids can be used to microfabricate non-metal ion emitters, extractors, accelerators that are highly modular. As a propellant, ionic liquids are very compact. In the intermediate phase of this team's research, ionic liquids are being used in the microfabrication of colloid thrusters, electrostatic accelerators of charged liquid droplets. These thrusters are efficient and flexible, and can be arrayed to increase thrust. In longer-term development are pure ion emitter arrays.

### Hall-type Ramjet:

The Hall-type ramjet uses a simplified Hall thruster to produce a well collated beam of xenon ions that traps electrons in a magnetic field and allows them to multiply as ionization continues. This simple design ionizes and accelerates ambient air molecules, and could provide a propellant-less and tank-less way to maintain a spacecraft in low orbit around Earth or Mars.

### Benefits and Innovations

- Through modeling and experimentation, this team is finding ways to improve propulsion efficiency, while making thrusters more compact and robust. New generations of liquid-based ion propulsion will be suitable for microsattellites, but could also be arrayed to provide more thrust as needed.
- Microfabrication makes manufacturing of thrusters easier and more cost effective. The resulting thrusters are also modular, speeding construction and repair.
- Hall-type ramjets, like all Hall thrusters, have high efficiency and thrust. Because they are propellant-less, they are being considered as options for station reboost and propulsion for long-duration space exploration.

### Status and Future Research/Developments

- A 250-channel microfabricated colloid array is now in testing.
- Pure ion emitter arrays, arranged in capillaries or externally wetted needles, are in testing.
- Although Hall thrusters have existed since the 1960s, the underlying physics are still not fully understood. The team is conducting modeling and experiments of Hall thrusters and Hall plumes, which can contaminate sensitive solar arrays.

### Contact

Manuel Martinez-Sanchez, Department of Aeronautics and Astronautics, Room 37-341, MIT, 77 Massachusetts Avenue, Cambridge, MA 02139, phone 617-253-5613, [mmart@mit.edu](mailto:mmart@mit.edu).

# Electromagnetic Formation Flight

Raymond Sedwick, Department of Aeronautics and Astronautics, MIT

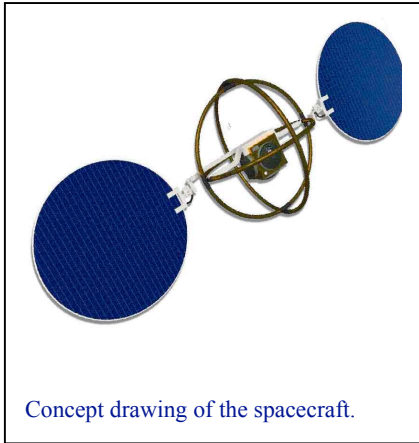

Concept drawing of the spacecraft.

Traditional propulsion uses the propellant as a reaction mass to help maintain attitude. However, this creates several disadvantages: propellant is a limited resource; momentum conservation (propellant moves the center of mass of spacecraft, resulting in momentum conservation) requires that the propellant mass increase exponentially with the velocity increment; and some propellants can contaminate the surface of optics and solar rays or leave clouds that obscure infrared telescopes, making them unsuitable for some spacecraft. The Electromagnetic Formation Flight (EMFF) team is developing an alternative that uses electromagnetic dipoles to control relative degrees of freedom between two or more vehicles. Each vehicle has three orthogonal electromagnetic coils, which act as dipole vector components and allow the magnetic dipole to be steered in any direction. Reaction wheels provide counter-torques. Multiple solutions to the dipole configuration allow freedom to move angular momentum between spacecraft to avoid wheel saturation.

## Benefits and Innovations

- EMFF can be used with a variety of telescopes and similar spacecraft without damage to sensitive instruments or negative impact on science return.
- EMFF frees missions from needing large stores of propellant to maintain attitude, a particular benefit for long-duration missions (over 6 years).
- EMFF can be used for in-space assembly of large structures. Animations depicting the general operation and specific application to assembly can be found at: <http://ssl.mit.edu/emff/index.html>.

## Status and Future Research/Developments

- The team is developing methods to de-saturate the reaction wheels without using thrusters.
- The team's preliminary experimental results indicate they are able to perform disturbance rejection in steady state spin dynamics for multiple satellites.
- The team has determined optimal system configurations and trajectory designs for relatively small satellite arrays; larger formations are being investigated.
- The flight hardware requirements appear to be within acceptable limits (power requirements are within a few hundred watts).

## Contact

Dr. Raymond Sedwick, Department of Aeronautics and Astronautics, Room 37-431, MIT, 77 Massachusetts Avenue, Cambridge, MA 02139, phone 617-253-7831, [sedwick@mit.edu](mailto:sedwick@mit.edu).

## Electric Propulsion Testbed on the ISS

Lee Morin, Astronaut Office, NASA Johnson Space Center

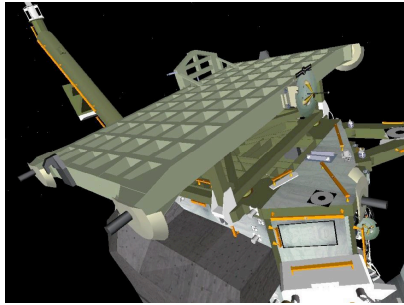

A concept drawing of the platform atop the Z-1 truss.

The International Space Station (ISS) is a unique microgravity laboratory, offering research space for experiments in biological and physical research, engineering, and Earth sciences. This project proposes using the ISS as an orbiting test facility where advanced power, power storage, and propulsion concepts can be demonstrated and evaluated in a real space environment.

Existing ISS resources would power instruments and test payloads as necessary and provide data download. A platform would be placed atop the Z-1 truss, which is structurally able to support such a platform. The position at midline, near the Station's center of mass, would be good for propulsive loads. Payloads would be exchanged robotically or by extravehicular activity.

Payloads that could be tested on the ISS include Hall thrusters, gridded ion thrusters, magnetoplasmadynamic (MPD) thrusters, variable specific impulse magnetoplasma rocket (VASIMR) engines, regenerative fuel cell technology (or hydrobus), space power storage/generation systems, and potentially others.

### Benefits and Innovations

- One of the major goals of the ISS as a program is to create a world-class laboratory for microgravity and space environment research. This would be the first "permanent" testbed for engineering research onboard the ISS. Propulsion and power systems can be tested and certified in a real space environment, serving a critical commercial, military, and civil need that cannot be met by other means.
- The researcher/payload would have ready access to a range of support facilities already available on the ISS, including power, video, computer interfaces, and communication. The station crew would be available to activate experiments, troubleshoot problems, or change out equipment as needed.
- The station's Z-1 truss, which sits at midline near the center of mass, would be used to test propulsive payloads, possibly providing ISS reboost and enhancing the microgravity environment by compensating for drag.
- Unlike other microgravity testing methods, such as sounding rockets, the ISS facility would allow extensive, long-duration in-orbit research.
- The test payload can easily be retrieved and returned to Earth.
- Higher thrust tests may provide the ISS with incidental reboost. Smaller burns could be used as a tool to enhance the microgravity environment (i.e., reduce vibrations caused by acceleration) of the ISS.

### Status and Future Research/Developments

- The RTAS (Rocketdyne Truss Attachment System), which would serve as the testbed platform, is a proven payload interface.
- More research needs to be done on the thrust, drag, and flight design to better determine the advantages and disadvantages the platform would have on microgravity systems and the station in general.

### Contact

Lee Morin, Code CB, NASA Johnson Space Center, Houston, TX 77058, phone 281-244-7970, lee.m.morin@nasa.gov.

## Presentation Topic 2: Communications Systems

The ability to communicate is necessary for the use of any space system. From transmitting of telemetry information during launch and orbital maneuvering, to enabling the transfer of sensor readings and photographs to scientists on the Earth, to specifying new mission activities for in-space systems, communications links are a critical technology for every space operation. The mission of a space system drives the requirements for communications links. For example a planetary exploration satellite needs to communicate sensed data along with telemetry and tracking information across extremely long distances with little data interruption, but there is little need for extremely high data rates. Conversely a human mission in Earth orbit or on the moon needs to transmit a variety of operation information and voices in a timely responsive way, with as little interference as possible.

Scientists and engineers around the world are developing and testing new communications technologies, techniques, and network architectures that will help overcome these challenges and provide communications solutions to increasing complex space missions. The following presentations summarize communications challenges and important research in universities and within NASA to advance and improve space communications in the future. The summaries also include the results of a participant discussion of cross-cutting issues in the field of space communications, and potential new technologies to solve those issues that were considered by the participants.

| <b>Presentations on Communications Systems</b>     |                        |
|--|------------------------|
| New Space Communications Architectures             | Vincent Chan, MIT      |
| Alternative Concepts for Communications            | Joel Schindall, MIT    |
| Communications Technologies for Space Applications | Participant discussion |



# New Space Communications Architectures

Vincent Chan, Department of Aeronautics and Astronautics, MIT

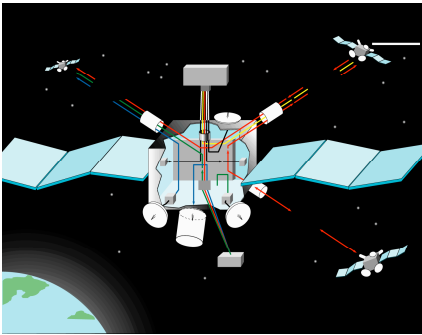

A drawing of the spacecraft LAN and relay node concept.

As space missions become more complex, relaying increasingly large amounts of data to Earth, the space communications architecture must evolve to meet this extreme demand. A technology to meet this demand is an optical space cross-link. Based on commercial technology that is space certified up to 1.5 microns, this cross-link would form the space backbone of a communications network, handling both digital and analog signals. An optical network, using full spectrum, would offer orders of magnitude increased capacity and would cost less than current systems. Spacecraft would link to the laser cross-link backbone, and optical routing and switching would then send signals to the terrestrial fiber backbone.

While the capacity of the space backbone is infinite, there would be a choke point at the optical and radio frequency (RF) downlink because of the atmosphere. A concept to minimize this choke point is to fly a spacecraft LAN and relay node, which would process raw data from

spacecraft users and compress the data for downlink. Multiple platforms would be distributed in low Earth orbit using a long-baseline technique. The mitigation approach to avoid downlink fade is to diversify with multiple transmitters and receivers. The Media Access Control (MAC) protocol would be designed to let the relay satellite assign communication resources to users, such as science missions that require high bit-rate communication, or to handle bursty, unscheduled users.

## Benefits and Innovations

- Optical space links are approaching the quantum limit, providing the capacity needed for the increasing number of orbital and long-range spacecraft.
- Designs for a new physical layer for optical and radio frequency up- and downlinks will help reduce congestion. High-flying aircraft, that would relay data to ground stations, may help diversify the link options.

## Status and Future Research/Developments

- The challenges that need to be addressed include: physical topology; modulation and coding; the MAC protocol; network routing protocol and hardware (the major goal is to find a single protocol that goes through the network); the transport layer protocol; network management and control; source coding; and Internetworking. (It is a goal of this project to obtain an understanding of the interactions between network layers so that overall, end-to-end performance can be significantly improved.)

## Contact

Vincent Chan, Department of Aeronautics and Astronautics, Room 35-304, MIT, 77 Massachusetts Avenue, Cambridge, MA 02139, phone 617-253-2471, chan@mit.edu.



## Alternative Concepts for Communications

Joel Schindall, Laboratory for Information and Decision Systems, MIT

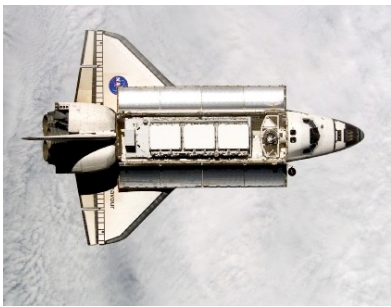

Schindall proposes using a cell phone onboard the Shuttle or ISS to test connecting to the Internet via communication satellites in LEO. Above is a photo of STS-113 (Endeavour) taken by the Expedition 5 crew in November, 2002.

Idea 1: Ground linking for experimental low Earth orbit (LEO) satellites is expensive and intermittent. Commercial companies have come up with two global communication systems based on LEO constellations that are readily available and do not have infrastructure costs (satellite direct to Internet). It would be possible for experimental LEO satellites to “phone home” via these networks. However, neither was designed to provide LEO service.

Idea 2: Processor and memory technology tend to improve several generations during the lifespan of a satellite. However, it is impractical to attempt to replace the existing equipment via docking or spacewalk. The alternative is to build the satellite with a robust network architecture and to incorporate a high-speed, short range link. An improved processor can be launched later and maintained in close proximity to the satellite, coupling it into the satellite network via the high-speed link.

Idea 3: The idea of pre-mission orbital refueling would be to launch the satellite and the mission fuel separately. The fuel would be transferred to the satellite during pre-mission insertion orbit.

### Benefits and Innovations

- Idea 1: The ability to have experimental LEO satellites link via LEO constellations, if the concept is validated and the equipment is space certified, would be a major cost saver over current methods.
- Idea 2: By launching upgraded processors and having it couple to a previously launched satellite via a high-speed link, satellites could be upgraded—and lifetime extended—in a cost-effective way.
- Idea 3: Launching satellite and fuel separately results in cost benefits. Since the fuel would not be factored into the payload, the satellite can be launched on a smaller vehicle or launched concurrently with another payload, reducing overall cost of the mission. The fuel transporter can be launched on a lower reliability, lower security launcher, such as a missile or foreign launcher. The cost of developing the fuel transporter can be amortized over several missions.

### Status and Future Research/Developments

- Idea 1: The data rate is low, the phones are not radiation hardened or space rated, and there are complex system issues of Doppler, acquisition, and hand off. Furthermore, the efforts to test this idea have died: difficult system simulation and component qualification is required, and the two network providers, Iridium and Globalstar, have neither the staff nor the economic motivation to pursue testing. This latter challenge can be met by buying a phone and adapter (an inexpensive 2.4/9.6 kbps), getting an inexpensive (~\$30) subscription, and evaluating the performance from the shuttle or International Space Station.

### Contact

Joel Schindall, Laboratory for Information and Decision Systems, Department of Electrical Engineering and Computer Science, Room 10-091, MIT, 77 Massachusetts Avenue, Cambridge, MA 02139, phone 617-253-3934, joels@mit.edu.

# Communications Technologies for Space Applications

## Participant discussion

Workshop attendees discussed future communications systems for a range of multi-disciplinary applications. They identified many challenges in developing future communication systems. For example, they noted that increasingly complex and large space systems will necessitate massive data transfers from space, that may require new



The workshop held at the MIT Stratton Student Center provided an opportunity for open discourse on a variety of data management and communications technologies.

architectures that rank transmissions to avoid bottlenecks and traffic jams. They discussed the need for much better power sources for wireless systems, such as advanced, standardized batteries or even wireless power transmission capabilities. They agreed on the importance of design and development that enabled the insertion of new technology over a system's life, and discussed reliance on commercial-off-the-shelf communications technology and software standards as one attractive strategy

The group discussed technology choices to address the challenges of future communication systems, considering the trade-offs in using different technologies. For example, laser-light (optical) digital communication can provide greater capacity and speed than radio-

frequency (RF) communication, making it an excellent choice for in-space transmissions. However, for multiple platforms, a single RF antenna can service a broad, angular area, while optics would require multiple antennas. Both optical and RF downlinks can be disrupted by atmospheric conditions. To avoid choke points, future communication systems must be hybrids that take advantage of the strengths of multiple technologies.

Related research activities that were identified ranged from improvements in the use of conventional RF spectrum use to highly conceptual approaches using neutrinos and quantum phenomena to communicate in space:

- **Better RF Spectrum Reuse.** Sending communications by RF is more secure than other types of communications because you can change frequency during communication. The current problem is that there are not enough frequencies to meet increasing demand. The goal is to create more avenues for communication without making the system bigger. Possible solutions include the use of "windows" within a frequency that can be divided into subdigits. Subdigits are an improvement over frequency allocation because they allow increased usage, greater security, and no need for bandwidth monitoring.
- **X-ray Communications:** Colorado State University is working on the use of an X-ray laser for communications. Technology challenges include: correlating and modulating data; noise containment; and the ability to detect information, rather than create new information.
- **Neutrinos.** Neutrinos readily travel through solid objects without distortion, making them attractive for communication purposes, particularly for over vast distances in space. They also travel near the speed of light. To enable this concept, smaller, user-friendly neutrino detectors must be developed.
- **Quantum Entanglement.** Quantum systems in an entangled state can be used as a quantum information channel to perform computational and cryptological tasks that are impossible in classical systems, such as an RF communication system. While entangled systems can interact across a large spatial separation, they cannot be used to transmit information on their own. It is possible to transmit information through a set of entangled states working in conjunction with a classical system; quantum entanglement can be used to detect the existence or nonexistence of data, but it cannot be used to generate new information. Research on this technology is being conducted at MIT, JPL, and in Australia and Russia.

## Presentation Topic 3: Automation, Robotics, Computing, and Intelligent Systems

From the earliest days of space exploration the necessity for automation and intelligent systems has been apparent; it was the driver of the earliest artificial satellites. Today as we advance the frontier of space applications and develop increasing complex space systems, technologies in the areas of automation, robotics, computing, and intelligent systems have become critical. All space systems -- both with and without humans -- require robust technologies that are able to conduct complex tasks independently.

In the case of un-crewed space missions, automation, robotics, and intelligent systems provide exploration craft and space systems with the flexibility to achieve a variety of mission activities without direct human involvement. Automation and robotics allow for the remote deployment of equipment, computing for the processing of complex information, and intelligent systems to make decisions enabling advancement when human input is unavailable. All of these technologies enable our use of space for exploration, scientific, or communications purposes without the cost and risk of human intervention.

For human space missions, these technologies improve the safety and reduce the risk of space travel. These technologies make living and operating in space easier for astronauts: providing in-space training for astronauts, robotic manipulation of large or cumbersome equipment, and improved environmental and safety systems. They also allow astronauts to spend more time on uniquely human activities, and less time on operations of the host spacecraft, thus increasing the operational efficiency of each astronaut.

Our ability to advance space exploration and the pursuit of in-space science activities will largely depend on our success in the advancement of automation, robotic, computing, and intelligent system technologies. The following presentations highlight some groundbreaking advancements in the technologies that make up this area.

| <b>Presentations on Automation, Robotics, Computing, and Intelligent Systems</b> |                           |
|--|---------------------------|
| Robust Autonomous Systems that are Self Aware                                    | Brian Williams, MIT       |
| Next Generation On-Orbit, Surface, and Subsurface Robotic Systems                | Karl Iagnemma, MIT        |
| Micro Chemical and Thermal Systems (MicroCATS)                                   | Robert Wegeng, PNL        |
| Collective Vision for Optical Technology   | George Barbastathis, MIT  |
| Modular Stability Tools for Distributed Computation and Control                  | Jean-Jacques Slotine, MIT |

## Robust Autonomous Systems that are Self Aware

Brian Williams, Model-based Embedded and Robotic Systems Group, MIT

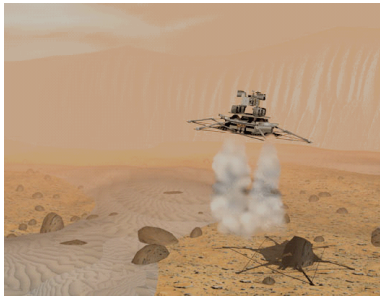

The Mars Science Lander, shown in this artist's concept picture, will provide a technology demonstration of robust autonomous systems.

To support complex, future space exploration missions, subsystems must be more than low-level processors for a vehicle. It takes, on average, six minutes for communications, sent from a vehicle on Mars to reach Earth, while missions to points beyond Mars will take even longer. This time “lag” is too long for a subsystem to wait for operator commands that will help it to respond to anomalies. Like an engineer, the subsystem must be able to reason through problems and select options without input from ground control.

The goal of this project is to create a family of model-based embedded programming languages (called RMPLs) that avoid common-sense mistakes, like those that caused the failures of the Mars Polar Lander and the Mars Climate Orbiter, by reasoning from hardware and software models. The embedded program specifies a time critical sequence in terms of the desired state of the vehicle over time. A model-based

executive then interacts with plant sensors and actuators to achieve these timed, state-based control programs. First, the executive reasons through probabilistic, timed models of nominal and off-nominal plant behaviors, in order to determine if a fault has occurred. The executive then uses these same models to generate a command sequence that achieves or restores the state, specified in the control program. In addition, to detect the onset of failures from subtle symptoms, the executive performs monitoring over continuous and discrete state changes. Finally, to improve robustness, tools are being developed to formally verify these model-based programs under failure.

### Benefits and Innovations

- These model-based, self-aware systems will robustly perform and monitor mission-critical sequences, such as orbital insertion and landing. Because these sequences involve a complex coordination between vehicle hardware components, faults often occur that endanger the mission, including novel failures and fault combinations. Model-based self-aware systems can isolate and correct for these novel failures as they arise.

### Status and Future Research/Developments

- A remote agent experiment to fully diagnose and repair a failure was conducted on Deep Space 1 in 1999.
- A technology “proof-of-concept” demonstration of RMPL and model-based execution is planned for the Mars Science Laboratory (MSL), which is planned for launch in 2009. Other current and future testbeds include: New Millennium Program ST-7 Phase A; Mercury MESSENGER (ground test); the MIT SPHERES experiment to be conducted on the ISS; the MSL science rover; NASA’s Robonaut; and simulated air vehicles.

### Contact

Brian Williams, Autonomous Systems Laboratory, Room 33-330 or  
Computer Science and Artificial Intelligence Laboratory, Room 32-273  
MIT, 77 Massachusetts Avenue, Cambridge, MA, phone 617-253-1678 (ASL) or 617-253-2739 (CSAIL),  
williams@mit.edu.

## Next Generation On-Orbit, Surface, and Subsurface Robotic Systems

Karl Iagnemma, Department of Mechanical Engineering, MIT



Robots with reconfigurable suspensions, like JPL's Sample Return Robot, can reposition their center of mass in response to changes in terrain. Active response gives these reconfigurable robots better mobility on steep and rocky terrain. The photos show the SRR with non-reconfigured (left) and reconfigured (right) suspension as the SRR goes over a steep hill.

Future space telescopes may be hundreds of meters in diameter and be comprised of thousands of unique pieces. Constructing such a telescope would be difficult and dangerous for human crews. Teams of robotic workers, on the other hand, would be well-suited to the task. The robots would be programmed to study the structure to determine the shape and structural mode. Similar skills can be applied to planetary rovers, which could go to locations inaccessible to humans. This would require improved mobility and sensors to allow the rovers greater capabilities over today's rovers. NASA's goal is to give rovers situational awareness so that they can adapt to environmental changes.

The Jet Propulsion Laboratory and MIT are studying articulated suspension robots that can go over rocks, down slopes, or adjust manipulators for greater stability. Current rovers have wheels that can raise and lower independently to help the rover navigate over small obstacles and modest

inclines, but the main body of the rover remains fixed. Articulated suspension, or "reconfigurable" robots, can alter their entire center of mass to respond to larger shifts in the terrains. This increased mobility and awareness is dependent on a combination of sensory information—video, tactile, and vibration data and analysis.

The next generation of planetary (surface and subsurface) explorers may be microbots, tiny robots that move by hopping and bouncing rather than on wheels. A team of these centimeter-scale robots would cooperate and share information. They could fit into caves and crevasses, providing a wider range of scientific data than traditional planetary missions.

### Benefits and Innovations

- The next generation of robotics would have increased mobility and articulation. They will also work cooperatively, sharing data and performing tasks that are beyond an individual robot or human. These cooperative robots could be used for in-space construction and surface and subsurface exploration.

### Status and Future Research/Developments

- Development continues on robotic technologies, with a focus on physics-based estimation, motion control, and planning. We need to develop new classes of actuators and control systems that are lightweight but have high power-to-weight ratio and control.
- Systems are being developed that can extrude structures in space, eliminating the need to launch parts that then need to be assembled. The team is not looking at inflatable structures, which are normally too flexible and floppy for a robot to manipulate, but may consider them in the future.
- Currently, robots return all data they acquire. As systems improve, robots will be developed to conduct autonomous on-board data fusion. Some data could be reduced to improve communication, but also the data could be useful to the robot, helping it navigate the terrain.
- Microbots may be possible in 10 to 40 years. The team has already demonstrated a hopping microbot. Enabling technologies that need further development include miniaturized video, higher data storage, chemical sniffers, and lightweight, more efficient power sources.

### Contact

Karl Iagnemma, Department of Mechanical Engineering, Room 3-435a, MIT, 77 Massachusetts Avenue, Cambridge, MA 02139, phone 617-452-3262, fax 617-253-9637, kdi@mit.edu.

## Micro-Chemical and Thermal Systems (MicroCATS)

Robert Wegeng, Pacific Northwest National Laboratory

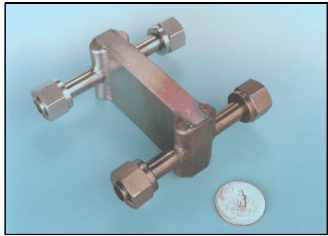

A microchannel heat exchanger, shown next to a quarter, can achieve up to 90 percent or better heat exchange efficiency.

The MicroCATS modular chemical processing chip consists of four cells each of microreactors and heat exchangers. The goal is to miniaturize systems for rapid heat and mass transfer, making them modular, smaller, and lighter weight. Borrowing from biological systems (where micro chemical-subsystems combine to form a complete, efficient system), MicroCATS operate in a distributed mode. These robust systems can withstand high heat duties, low pressure drops, and can be more energy efficient than non-distributed systems. Microchannel heat exchangers can withstand heat up to 25 watts/cm<sup>2</sup> and can effectively transfer up to 90 percent (or greater) of heat. An example is an *in-situ* propellant production (ISPP) reactor system, which combines a microchannel reverse water-gas shift (RWGS) reactor, which is endothermic and favors high temperatures, with a microchannel Sabatier process reactor, which is highly exothermic and favors low temperatures. The

exothermic heat from the Sabatier Process reaction partly supports the endothermic RWGS reaction, providing improved energy efficiency.

For space applications, MicroCATS may be used as: compact propellant production system for methane and oxygen production on Mars; hydrogen generation from hydrocarbon fuels for fuel cells, where it has been demonstrated to provide hydrogen for more than a 1.5 kWe fuel cell; ISS oxygen regeneration, where it would regenerate oxygen from carbon dioxide and water, closing the oxygen cycle on the station; compact heat pumps for spacesuits and compact fuel processors for power generation during extravehicular activities; and thermal chemical process networks, such as chemical plants on a spacecraft or planetary/lunar habitat.

### Benefits and Innovations

- MicroCATS are compact and can go where traditional chemical and thermal systems cannot. They are also lighter weight, reducing launch mass and cost.
- MicroCATS are similar to electronics in that they can be mass-produced by machine, not labor, reducing cost. The MicroCATS team visualizes that MicroCATS could become an integral part of lunar or Mars bases, where they would not only be used as heat exchangers, but also as miniaturized chemical plants for processing in-situ resources into materials for fabricating more MicroCATS and other needed components—a self-growing lunar factory.
- MicroCATS are modular, making repair and alteration easier. Subsystems can be swapped out or modified to fit specific applications.

### Status and Future Research/Developments

- This program receives support from NASA, the Defense Advanced Research Projects Agency/Department of Defense, and the Department of Energy.

### Contact

Robert Wegeng, Pacific Northwest National Laboratory, K6-28, P.O. Box 999, Richland, WA 99352, phone 509-521-8244, robert.wegeng@pnl.gov.



## Collective Vision for Optical Technology

George Barbastathis, Department of Mechanical Engineering, MIT

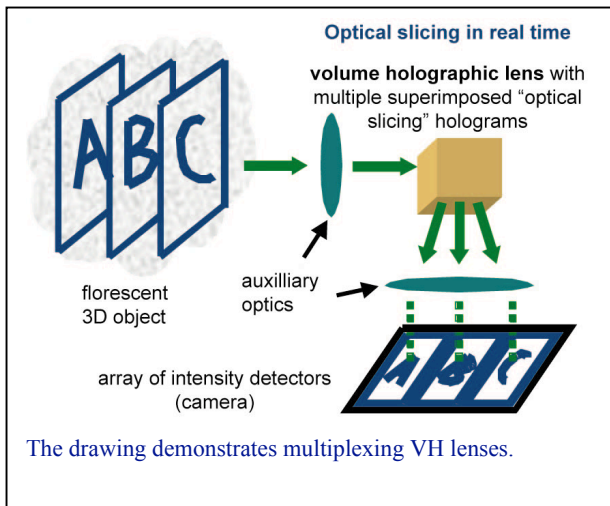

The next generation of three-dimensional imaging will not involve scanning. Instead, it will be optical slicing in real time—essentially using a hologram as a smart lens. Volume holograms (VHs) are created by interfering at least two (mutually coherent) optical beams over the volume of a photo-sensitive material. Unlike traditional thin holograms, which indiscriminately diffracts ambient illumination so as to create the illusion of three-dimensionality, VHs are selective about the wavelength and angle of light they refract (a property called Bragg selectivity). This results in excellent depth and resolution, as well as wavelength selectivity (potentially useful in telescope applications). A major application would be for reconnaissance, where it would obtain a three-dimensional image of a ground target with better than one-centimeter accuracy. This could be obtained through the collaboration of multiple

unmanned air vehicles (UAVs). VHs can also be used for other types of imaging, data storage (where they offer large data storage densities, fast parallel access, and rapid searches), and data communications (where it can be used for fast optical networking), accomplished via a single moving agent or multiple agents working cooperatively.

### Benefits and Innovations

- Volume holograms allow real-time, three-dimensional imaging, which would be a major advance for reconnaissance and scientific imaging, including use in telescopes.
- Volume holograms offer a rich selection of responses, unlike traditional optical elements such as lenses and focal stops.

### Status and Future Research/Developments

- Collective imaging needs to be demonstrated at long distances; this would be easier in space, since there is no atmospheric turbulence.
- Statistically savvy algorithms need to be developed.
- Cooperative motion between agents needs to be optimized without sacrificing other functions.

### Contact

George Barbastathis, Department of Mechanical Engineering, Room 3-461c, MIT, 77 Massachusetts Avenue, Cambridge, MA 02139, phone 617-253-1960, fax 617-258-9346, gbarb@mit.edu.

## Modular Stability Tools for Distributed Computation and Control

Jean-Jacques Slotine, Department of Mechanical Engineering, MIT

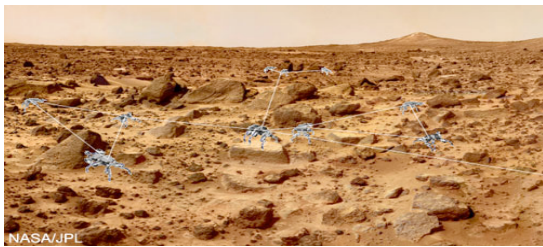

Control and stability tools will enable groups of robots to act as an efficient group.

Dr. Slotine's work examines swarming behavior, such as flocks of birds or schools of fish where individuals work in a synchronized group, and asks how to get consistent behavior out of groups by using only local, non-linear interactions. This would be applicable to robots that are used in groups for space exploration (such as a group of rovers on a planetary surface) or in-situ construction, or even to coordinate multiple legs on the same vehicle. The goal is to create robust distributed algorithms that will control the group.

### Benefits and Innovations

- Control and stability tools are critical to the proper functioning of legged robots and to coordinate groups of robots.

### Status and Future Research/Developments

- On-going research project.

### Create

### Contact

Jean-Jacques Slotine, Nonlinear Systems Laboratory, Department of Mechanical Engineering, Room 3-338, MIT, 77 Massachusetts Avenue, Cambridge, MA 02139, phone 617-253-0490, fax 617-258-5802, [jjj@mit.edu](mailto:jjj@mit.edu).



## Presentation Topic 4: Transformational Techniques for Space Activities

New technologies do not automatically guarantee a successful mission. The ability to conduct successful missions is integrated with our ability to manufacture technologies and systems that are necessary for space activities; our ability to keep cost and risk at bay through the use of modular space architectures; and, our ability to manage the development of the system and improve the process and engineering for future systems. This session included presentations on developments in each of these areas.

Presentations in the area of manufacturing advancements for space activities were: a review of improvements in the field of computer-aided manufacturing which could be used for potential in situ manufacturing and in a variety of other space missions; advancements in the field of small-scale engineering tubes that are biologically inspired and have potential applications in a variety of space structures; and, fabrication methods that use increasingly smaller scales that allow for technologies that are affordable and practical, yet technically complex and robust.

Three presentations emphasized the importance of modularity in planning, designing, and operating space systems. They addressed: the potential for risk and cost savings through the scaled deployment of space systems; the importance of considering extensibility in the planning and development of space systems to help reduce life cycle cost, deployment time, and risk for space systems; and, the potential advantages of using modular reusable components and elements to achieve a variety of complex space missions.

Advancements in management techniques for space missions were also captured during the workshop, in three presentations that covered: incorporating the principles of lean manufacturing into the aerospace industry by transitioning to a collaborative environment and focusing on fact-based decision-making; improving knowledge capture to engineer safer systems and to maintain safety in increasingly complex space architectures; and using the ISS as a technology test bed for space-based technologies to reduce risks for future space systems.

| <b>Presentations on Transformational Techniques for Space Activities</b>  |                       |
|---|-----------------------|
| Why Cutting Paths are Different from Robotic Paths: Sensor and Navigation   | Sanjay Sarma, MIT     |
| Tubular Structures  | Lorna Gibson, MIT     |
| Avogadro-Scale Engineering  | Neil Gershenfeld, MIT |
| Staged Development of Complex Systems   | Oliver de Weck, MIT   |
| Extensibility in Space Transportation   | Ed Crawley, MIT       |
| Modular Reusable Space Architecture   | Jim Geffre, NASA      |
| Lean Aerospace Initiative   | Terry Bryan, LAI      |
| Advanced Systems and Safety Engineering Environments  | Nancy Leveson, MIT    |
| Using the International Space Station as an Engineering Technology Research Laboratory for Space-Based Telescopes | Dave Miller, MIT      |

## Why Cutting Paths are Different from Robotic Paths

Sanjay Sarma, Mechanical Engineering, MIT

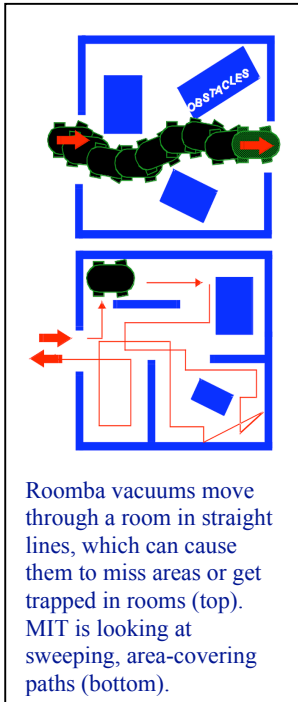

Computer-aided manufacturing (CAM) is an expensive process involving manually mapping the path a cutting tool will travel. Cutting paths, like robotic paths, revolve around obstacle avoidance, except that cutting paths move through three-dimensional space, whereas robots usually move around obstacles in two dimensions. The termite, a cutting tool analog, plans its path based on three types of areas: free space, soft obstacles, and hard obstacles. It chews through soft obstacles, creating a free space through which it can haul its body. This type of path—where a cutting head clears a path that allows the non-cutting portion to follow—is still difficult to duplicate via CAM. Traditionally, the tool must remove all soft material to get from point A to point B. A second type of problem involves posture maps which, for example, involves an angled surface populated by angled hairs. The cutting tool has to angle and correct to find the optimal path around hard obstacles using the least amount of movement.

There are different methods for finding the optimal tool path. Traditionally, the field of robotics has concentrated on moving directly from point A to point B. The new trend is area sweeping. For example, an autonomous, unaware robot such as a Roomba floor vacuum moves in a straight line until it runs into a hard obstacle, forcing it to change course. It will follow this new course until it runs into another hard obstacle, whereupon it changes course again, and so on until it has covered the free space. This method follows a random path, meaning that each vacuum will chart its own path through a space. One Roomba may miss a room within a complex space, while another vacuum may successfully clean all rooms.

MIT is addressing cutting path challenges to create new approaches to CAM, such as low-cost radio frequency identification (RFID) tags, networking and sensing, mesh networking, data management, and inferencing. A termite leaves a chemical trail that helps it navigate through its three-dimensional environment. MIT is exploring ways that cutting tools can leave RFID tags, which act like buoys, at critical points as they move through the material being machined. The cutting tool would cover the entire space, much like a Roomba floor vacuum, leaving behind RFID tags as it sweeps, eventually creating a three-dimensional mesh that it could communicate to other cutting tools.

### Benefits and Innovations

- Future long-duration, beyond-LEO human space exploration will depend on in-situ fabrication of new and replacement parts. Current fabrication methods are difficult, cost-prohibitive, and require unwieldy equipment. Improved CAM would enable better in-situ fabrication.
- Sensor and navigation advances could be applied to exploration robots. Current exploration robots follow relatively simple, two-dimensional paths. They are incapable of navigating over complex terrain, limiting the types of surface they can cover. Using advanced sensors and navigation, future robots may be able to navigate complex, three-dimensional surfaces or mine through a planetary surface, either as an individual or as part of a network of robots.

### Status and Future Research/Developments

- MIT is developing new approaches, using RFID tags, sensor, networking, and data management technologies, that will make CAM easier and more cost-effective.

### Contact

Sanjay E. Sarma, Department of Mechanical Engineering, MIT, Room 35-010, 77 Massachusetts Avenue, Cambridge, MA 02139; phone 617-253-1925; fax 617-253-7549; sesarma@mit.edu.

## Tubular Structures

Lorna Gibson, Department of Materials Science and Engineering, MIT

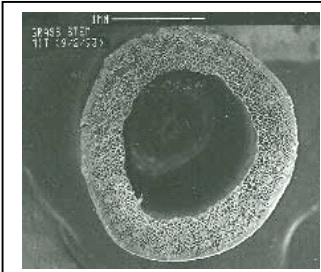

A grassy stem with a core of compliant material provides inspiration for new engineering tubes.

Small-scale engineering tubes, with their large ratio of radius to thickness, are relatively inefficient in resisting bending and buckling loads. Large diameter engineering tubes, on the other hand, have longitudinal and circumferential stiffeners, allowing the outer shell to be thin, and giving a more efficient component in bending and buckling. Natural tubular structures have a dense outer shell supported by honeycomb-like or foam-like core. The core plays the same role as the stiffeners in large scale engineering tubular structures, increasing the bending and buckling resistance. Examples include grassy stems, like the one shown on the left, porcupine quills, and bird feather rachis (the quill part of the feather). In plant stems, the central part of the tube is typically hollow as the mechanical loads are negligible in the central part of the core. In quills and feather rachis, the cores are completely filled with a foam-like material, which increases their thermal insulation.

These natural materials have inspired the concept of biomimicking the design of tubular structures: tubes with a compliant core material, rather than individual stiffeners; honeycombs or foams as core materials, with scale limited only by the cell size of the porous core; and the potential for stiffened tubular structures at smaller scales.

An elastic buckling analysis of bio-inspired tubes shows that their buckling pattern is different than traditional tubes and that they possess increased buckling resistance. The MIT team performed experiments on rubber tubular shells with empty and partial foam cores. The shell with a thin layer of core material resisted buckling better and stresses within the core decayed rapidly.

### Benefits and Innovations

- Research suggests that by including a porous core of compliant material, we can design tubes with increased buckling resistance at comparable weight, or conversely, with constant buckling resistance and reduced weight.

### Status and Future Research/Developments

- Additional research is needed to optimize tubular structures at smaller scales by bio-mimicking natural tubular structures. A research team at MIT will compare the performance of four configurations (empty, foam, sandwich wall, and axially stiffened shell) and analyze normalized weight versus normalized load. This research will examine three failure modes: overall elastic buckling, local buckling, and yield.

### Contact

Lorna Gibson, Department of Materials Science and Engineering, Room 8-135, 77 Massachusetts Avenue, Cambridge, MA 02139, phone 617-253-7107, fax 617-253-6275, ljgibson@mit.edu.

## Avogadro-Scale Engineering

Neil Gershenfeld, Center for Bits and Atoms, MIT

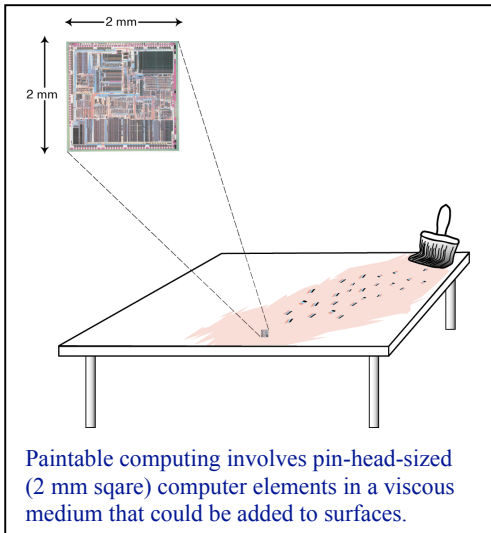

Current fabrication methods are orders of magnitude away from the limits governing how molecules can be ordered. The challenge is to find ways to push this boundary and engineer on increasingly smaller scales. The problem may not be that the technologies and design methodologies are not yet possible, but because the approach is getting in the way. The goal of Avogadro-scale engineering (ASE) is to design and build systems that are at the boundary of complexity and scale, while keeping these systems affordable and practical. MIT's program is trying to determine the resources, such as error-correcting fabrication, fault tolerant hardware and software, and nonlinear functional approximation, that will enable exponential increases in complexity and physical degrees of freedom.

One possible result of ASE is that a range of technologies, from computers to spacecraft systems, could be greatly reduced in size—possibly to molecular scale. For example, process technologies for computers will reach the point where autonomous

computer elements are reduced to the size of a grain of sand and can be purchased cheaply in bulk. With a commensurate shrinking of sensors and actuators, the personal computers will be transformed. Processors, program memory, and wireless transceivers, reduced to the size of a pinhead, can be randomly deposited by the thousands in a viscous medium. When power is applied, these elements would communicate with their neighbors in the fluid, boot, and self-assemble to form a “paintable” computer. This paintable computer could conceivably be added to surfaces, such as building materials or paper, to make them smarter.

ASE research also seeks to determine optimal architectures that can be fabricated affordably in large quantities or to reveal automated ways to reveal this architecture, where one only needs to define the initial and final states and the automated system discovers the optimal architecture.

### Benefits and Innovations

- If successful, ASE could make it possible to take microfabrication to a new scale. Systems and processors could be greatly reduced in size and mass and designs could be optimized to improve fabrication. This would have a huge impact on future space missions: vehicles and systems would be smaller and lighter, reducing overall mission cost, and in-situ fabrication would be easier and require less materials.
- ASE may reduce the size of computers, so that they can be incorporated into a range of technologies, and to expand their capabilities to include, for example, three-dimensional displays and improved interfaces. The future of computing, as aided by ASE, would result in intelligent systems that could be incorporated into almost any object. This would greatly increase usability, resulting in computer interfaces that could easily be incorporated into spacesuit gloves or the surface of a work table onboard a spacecraft. Any space flight system could incorporate new degrees of adaptability and expandability.

### Status and Future Research/Developments

- Avogadro-scale engineering is still at the conceptual and research phase, and it is difficult to predict how ASE will affect future technologies.

### Contact

Neil Gershenfeld, Center for Bits and Atoms, Room E15-411, 20 Ames Street, Cambridge, MA 02139, phone 617-253-0392, gersh@cba.mit.edu.

## Staged Deployment of Complex Systems

Olivier de Weck, Space Systems Laboratory, MIT

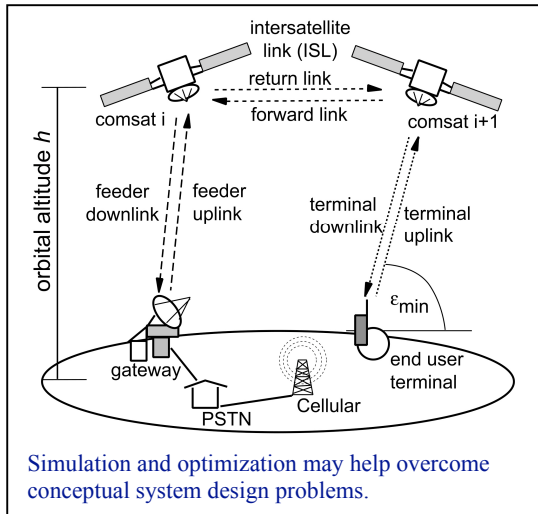

Both Iridium and Globalstar were economic failures because the forecasts overestimated the demand for space-based cellular phones. The traditional method for deploying a system is to conduct a market survey of the service to be offered, derive system requirements, define an architecture for the overall system, to design and optimize the system, launch the system, operate and replenish as needed, and then retire at end of life. The system is usually sized to optimistic capacity or usage estimates. This leaves no flexibility to reduce or expand a system based on market reality. The reality is that it is impossible to predict how much capacity a system will need. Over capacity is a waste and under capacity is a missed opportunity.

An alternative would be to embed the capability to deploy systems in stages up front. A smaller, more affordable system is built. This system has the flexibility to increase its capacity if demand is sufficient and the operators can afford additional

capacity. The new process is to: conduct a market survey of the service to be offered; conduct baseline architecture trade study; identify paths for staged deployment; select an initial stage architecture (based on a real options analysis); obtain FCC approval for the system, implement, and launch; operate and observe actual demand; and make periodic reconfigurations up to end of life. It is true that making a system extensible in this way may require some upfront cost, performance or mass penalties compared to an inflexible system. These penalties, however can be shown to be worthwhile if the value of flexible deployment and corresponding risk reductions can be rigorously quantified. The paradigm shift is that space systems architects should optimize the evolutionary path of systems, rather than rigid point designs.

### Benefits and Innovations

- This approach reduces the risk of either creating a system with too much or not enough capacity, problems that can result in economic failure. The staged deployment strategy reduces the economic risks via two mechanisms: the costs of the system are spread out across entire life cycle; and the decision to deploy is done by observing the market conditions. Either demand will not outgrow the initial system or, if demand is important enough, profits may be sufficient to deploy a next stage.
- The design and valuation methodologies that support staged deployment are also applicable to non-commercial systems. The question of how Moon-Mars Exploration systems could best be deployed in stages can also be attacked with these techniques.

### Status and Future Research/Developments

- Reconfiguration of satellite constellations needs to be studied and issues need to be resolved: estimate delta  $V$  and transfer time for different propulsion systems; study the possibility of using a tug to achieve reconfiguration; study response time; and analyze the possibility of service outage and mitigation strategies during staging operations.

### Contact

Olivier de Weck Ph.D., Assistant Professor, Space Systems Laboratory, Department of Aeronautics and Astronautics, Room 33-406, MIT, 77 Massachusetts Avenue, Cambridge, MA 02139, phone 617-253-0255, fax 617-258-0863, [deweck@mit.edu](mailto:deweck@mit.edu).

# Extensibility in Space Transportation

Ed Crawley, Department of Aeronautics and Astronautics, MIT

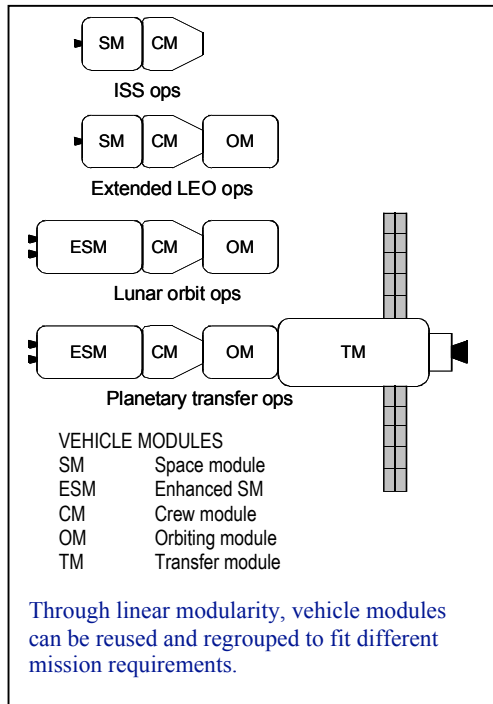

Extensibility, as a subset of flexibility, is the ability to add new elements to a system in a way that alters the value delivered. An extensible system would be able to deliver new value at considerably lower life cycle cost than a non-extensible system. To achieve extensibility, we must anticipate and understand future goals and environmental changes, and then translate this understanding into upfront system design actions that are aimed at minimizing overall lifecycle cost. The four characteristics of extensibility are agility (a system's ability to change rapidly), adaptability (a system's ability to adapt itself without external actuation), flexibility (a system's ability to be changed easily), and robustness (a system's ability to be insensitive to changes in its environment).

A theoretical framework exists to support design for flexibility and extensibility: outcomes of flexibility, which is based on a change of operand and attributes and/or function and attributes at minimum life cycle cost; topology of flexibility, which includes reconfigurability, platforming, and extensibility; style of connectivity, such as slot, bus, or sectional; principles of flexibility, such as ideality, modularity, independence, and integratability; and provisions for extensibility, which include the master plan, resources, and interfaces.

A Space Transformation Master Plan, based on a reasonable projection of activities between 2010 and 2020, is needed to create a set of scenarios that span the likely evolution that will take place. For a sortie mission to the lunar surface, for example, the plan will address the outcomes of flexibility, such as the operand (crew size or cargo) and functions (orbital operations, Earth reentry). Extensibility may be more applicable at the subsystem level, such as propulsion, robotics, power systems, and such. Modularity at this level would allow technology to be upgraded as it evolves.

## Benefits and Innovations

- Extensibility offers a reduction of overall life cycle cost, due to reuse, commonality, and ease of learning.
- There would be reduced development time and cost for new functions due to commonality.
- Deployment could be done in stages, which would be a benefit in times of fluctuating budgets and policy changes.

## Status and Future Research/Developments

- Flexible systems are not always the optimal system.
- Extensibility must be designed into the system and not left to chance. That results in up front costs, however, this up front cost would yield long-term cost savings if implemented properly.

## Contact

Ed Crawley, Department of Aeronautics and Astronautics, Room 33-207, MIT, 77 Massachusetts Avenue, Cambridge, MA 02139, phone 617-253-7510, [crawley@mit.edu](mailto:crawley@mit.edu).

## Modular Reusable Space Architecture

Jim Geffre, Advanced Development Office, NASA Johnson Space Center

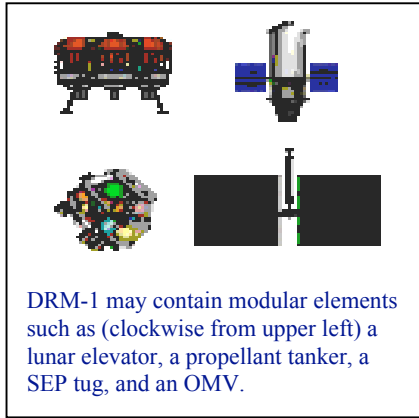

Modular, reusable space architectures will enable robust, routine transportation of people and payloads to and from low Earth orbit (LEO) and higher energy orbits. This strategy reduces the number of custom or unique flight elements and system components, replacing them with modular elements that could be used for several missions or easily swapped out and upgraded. There are currently three design reference missions (DRMs) featuring modular architectures. DRM-1 is a human lunar mission where a crew transfer vehicle would be fueled by a tanker in LEO, transferred to lunar orbit and descended to the lunar surface, returned to lunar orbit where it is refueled by another tanker, and returned to LEO. DRM-2 is a geosynchronous orbit (GEO) communication satellite/science platform deployment; DRM-3 is the deployment of an L2 Earth observation telescope. Some conceptual flight elements include the following:

A lunar elevator would be used to transfer crew from LEO to destinations in Earth-moon space and then return to LEO. The major advantage to the lunar elevator would be that it only operates in space. It allows mass-efficient lunar exploration scenarios with a single crewed vehicle. Systems that could be modularized are the propulsion/thruster/engines, avionics, and life support.

A solar electric propulsion (SEP) tug would deliver payloads and from LEO to high-energy orbits and return. It could reduce beyond-LEO transportation costs and reduce required launch vehicle capacity. The modular systems include electric thrusters, photovoltaic arrays, and a common spacecraft bus.

A propellant depot would be used to refuel space-based assets. The depot would reduce launch requirements and beyond-LEO transportation costs, and would provide propellant on demand, possibly extending the life of satellites. The modular systems would be the cryogenic storage systems, fluid transfer, and power systems.

An orbital maneuvering vehicle (OMV) would transfer propellant launch packages to SEP tankers, move payloads through small orbital changes, and safely deorbit hardware. This would allow designers to reduce the functionality requirements of propellant delivery segments and would reduce SEP tanker maneuvering and propellant usage. The modular systems would be propulsion/thrusters and avionics.

A reusable injection stage would inject payloads or crew transfer vehicles to high-energy destinations around Earth or provide major orbital maneuvers for strategic space assets. This would reduce the cost of payload deployment by using a reusable vehicle and modular systems (which would be propulsion/thrusters/engines and avionics).

### Benefits and Innovations

- Past exploration missions were highly specialized, with hardware and systems designed for a specific goal. This requires a major infusion of money up front. The new paradigm emphasizes modular, reusable architectures that can be gradually built up and upgraded as needed, spreading cost over time.
- Modular, reusable systems allows systems to serve the needs of different customers. This saves development time and cost.

### Status and Future Research/Developments

- Several enterprises within NASA (Space Flight, Space Science, Biological and Physical Research, and Earth Science), as well as the Department of Defense, the National Oceanic and Atmospheric Administration, and industry), are involved in this activity. Several DRM types have been identified, but none have been scheduled.

### Contact

Jim Geffre, Advanced Development Office, Code EX, NASA Johnson Space Center, 2101 NASA Road 1, Houston, TX 77058-3696, phone 281-483-1336, fax 281-483-5800, james.r.geffre@nasa.gov.



## Lean Aerospace Initiative (LAI)

Terry Bryan, LAI

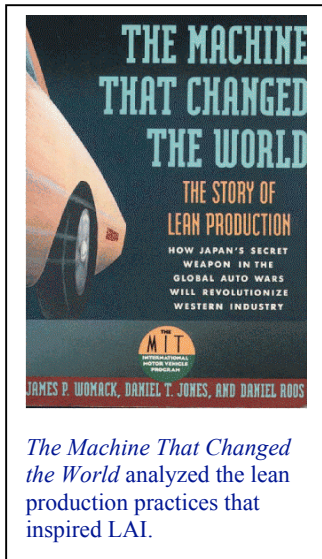

In the early 1990s, aerospace was faced with a tighter economy and the need to cut their budgets. The U.S. Air Force asked whether the military aircraft enterprise could adopt the practices of Toyota Production System (analyzed in the MIT publication, *The Machine That Changed the World*), which made Toyota a world leader in automobiles and related technology. The Toyota Production System fostered an environment where each worker was considered a problem solver and process owner, responsible for maintaining quality as the product moved upstream. Toyota also maintained minimal inventory, cut waste, and remained responsive to industry changes. The result was high productivity, low costs, and a quality product, or “lean” production. The Air Force’s question resulted in the creation of LAI.

Formed in 1993, LAI is a consortium of aerospace stakeholders from industry, academia, and government. It identified the best practices of the lean automobile factory, developed lean roadmaps, and began modeling those practices into management techniques relevant to aerospace. By 1999, LAI was focused on enterprise research, emerging systems thinking, the transition from minimizing waste to creating value, and leveraging the consortium’s knowledge. Today, LAI is action oriented, fact based, and delivering value to the U.S. aerospace enterprise.

The “Lean Now” initiative is a program that helps teams become lean by applying lessons learned by LAI. The initiative emphasizes collaboration, instead of competition, to achieve mutually beneficial goals and deliver better products. The process includes workshops to discuss scope and goals with program team, training with team facilitators, and improvement activities monitored through progress reviews and metrics. The Lean Now objective is to identify barriers to improvement and change, improve communication, and eliminate waste. However, LAI stresses that transformation is not a quick, easy process. Transformation requires deliberate leadership planning and action, credibility (both internal and external), a total enterprise approach, and constant nurturing. Most importantly, transformation means risk taking.

### Benefits and Innovations

- LAI has demonstrated its value—through cultural behavior change and new capabilities and skills—to the aerospace enterprise. Some results from Lean Now include:
  - Combined Test Force Operational Flight Program Load (F/A-22)—software install time reduced 50-95 percent; 56 percent reduction in non-value-added steps; implemented a Web-based spares ordering system; dedicated parts research; and parts purging within CTF compound.
  - Alpha Contracting (Global Hawk)—37 percent initial cycle time reduction; \$49 million life cycle savings for integrated sensor suite; \$33.8 million additional life cycle savings; 38 percent production cycle delivery time savings; and an additional \$5 million estimated producibility savings.
  - The subcontractor audit process was reduced from more than 26 weeks to only seven.

### Status and Future Research/Developments

- Although LAI members have noted great improvement in production operations, the greatest benefits will only come when entire enterprises, including operating, technical, business, and administrative units, are following lean practices.

### Contact

Terry Bryan, Center for Technology, Policy, and Industrial Development, Room 41-205, MIT, 77 Massachusetts Avenue, Cambridge, MA 02139, phone 617-253-8583, tbryan@mit.edu.



# Advanced System and Safety Engineering Environments

Nancy Leveson, Department of Aeronautics and Astronautics, MIT

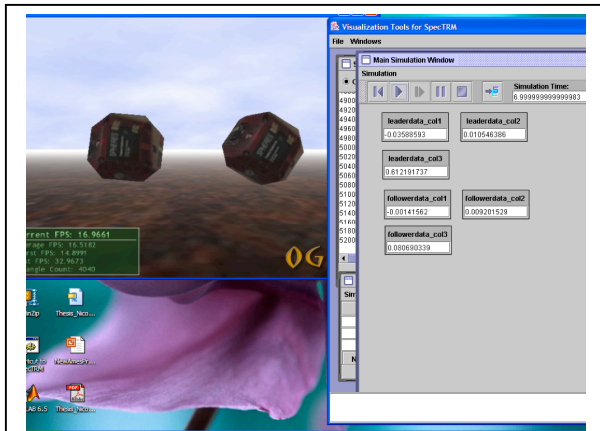

A screen capture of a SPHERES spacecraft simulation using executable SpecTRM specifications of the system components. The behavioral requirements can be validated before any software or hardware is constructed.

SpecTRM (Specification Tools and Requirements Methodology) is a system engineering toolset that can be used to design component-based system architectures that reuse system engineering artifacts (not detailed design), to capture and reuse design rationale, and to build executable specifications to validate requirements so that errors can be detected and fixed early. Safety-related analyses and design constraints are integrated into the development environment so they are available to the engineers early in the design process and can be used in system trades and design decisions. The tools are based on a new way of structuring specifications called intent specifications. Intent specifications use a type of “why” abstraction to allow complete traceability of engineering decisions.

A second (related) area of research involves new approaches to ensuring safety in complex systems. Traditional hazard analysis techniques are based on a model of accidents that assumes they result from chains of component failure events. STAMP (Systems-Theoretic

Accident Modeling and Processes) is a new model of accident causation that instead assumes accidents occur due to inadequate enforcement of safety-related constraints on system components and their interactions. For example, the Mars Polar Lander was lost not because the software failed (in fact, it satisfied its requirements and did not fail) but because the logic did not adequately control the lander’s descent speed. STAMP includes all the traditional component-failure accidents but it also explains accidents involving interactions among non-failing components, software-related accidents (which usually are related to incorrect requirements rather than coding errors), and human-errors. The entire socio-technical system is treated as an integrated whole, which allows preventing a large class of accidents including those related to flawed management decisions and flaws in the safety culture. Using STAMP as the basic model of causation, new hazard analysis, root cause analysis, risk assessment, and performance monitoring approaches are being created and experimentally validated.

## Benefits and Innovations

- Executable specifications and reusable models can greatly reduce the cost of producing software-intensive systems. Intent specifications also integrate the design rationale into the specification structure itself, thus providing knowledge capture and reuse of engineering designs. In addition, integrating the safety information into the specification enhances safety by making necessary information available to decision-makers early in the design process when safety-critical decisions are being made. New accident models, based on systems theory, can provide the hazard and risk information needed for today’s complex, software-intensive, human-centered systems.

## Status and Future Research/Developments

- SpecTRM technology has been transferred to a commercial product. As new ideas and research are generated and validated by researchers at MIT, they are incorporated into the commercial tool. STAMP-based hazard analysis is now starting to be used successfully on industrial systems.

## Contact

Nancy Leveson, Complex Systems Research Laboratory, Department of Aeronautics and Astronautics, Room 33-334, MIT, 77 Massachusetts Avenue, Cambridge, MA 02139, phone 617-258-0505, leveson@mit.edu.

## Using the International Space Station as an Engineering Technology Research Laboratory for Space Based Telescopes

Dave Miller, Space Systems Laboratory, MIT

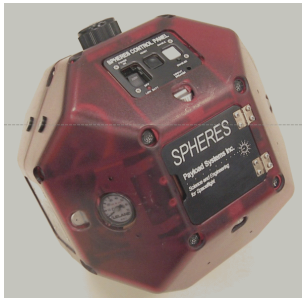

The SPHERES experiment, to be flown on the ISS, will test formation flight using three “satellites” like the one shown here.

The ISS offers several attractive capabilities as a technology development laboratory. It has the infrastructure (e.g., power, computer, video, communication) to support research payloads; the payloads are easily retrieved, or they can be upgraded on orbit for further testing; and the crew would be available to help with experiments, troubleshooting, and upgrades. Telescopes could be fabricated at or near the ISS via robots or crew extravehicular activity. This allows the telescope to be checked out and repaired in a real space environment before it is deployed. Even when it is not desirable to construct the telescope at the ISS (due to contamination or orbital transfer issues), the ISS would provide a good place to demonstrate techniques for telescope deployment. Technologies that could be developed on the ISS include deployable/erectable systems (human, robotically, or automatically deployed systems) and support systems such as electric propulsion testbeds and laser communication. The ISS could also be used as an exposure facility for testing mirrors, detectors, and actuators.

The types of experiments that are appropriate for the ISS include demonstration and validation, repeatability and reliability (demonstrate reliable and repeatable behavior in a microgravity environment), determination of simulation accuracy (may reveal features that should be modeled), and identification of performance limitations (space may provide the only reliable test of performance for some systems).

### Benefits and Innovations

- The ISS would allow telescopes and telescope systems to be tested in space. Some issues can only be revealed in an environment similar to the telescope’s operating orbit. The microgravity environment can also be used to investigate phenomena that would affect performance, such as gravity-dependent, non-linear relaxation. This would eliminate errors like the ones that plagued the Hubble Space Telescope.
- The station crew would provide additional laboratory capabilities. They could assist experiments so that the research payloads do not need to be completely autonomous. They could also troubleshoot and upgrade payloads as needed.

### Status and Future Research/Developments

- SPHERES still awaits flight, after the loss of Columbia, with Progress-17 looking favorable in March 2005. In the meantime, SPHERES is undergoing ground tests in support of tethered systems, spacecraft autonomy, and space-based interferometers.

### Contact

Dave Miller, Space Systems Laboratory, Department of Aeronautics and Astronautics, Room 37-327, MIT, 77 Massachusetts Avenue, Cambridge, MA 02139, phone 617-253-3288, millerd@mit.edu.

## Next Steps

NASA, in response to the new Vision for Space Exploration, is working hard to make sure its frame of reference encompasses those innovative approaches and technologies, that have the potential to transform how the U.S. Space program achieves future exploration missions — to make our systems and missions more affordable, reliable, effective and flexible. No matter which technologies and system concepts NASA ultimately adopts, it will most likely take a stepping-stone approach to developing the future generations of space infrastructure. This meshes well with NASA's new exploration roadmap, which envisions a stepping-stone ('spiral development') approach to achieving the goals of returning humans to the Moon, sending robotic missions to multiple targets throughout our solar system, and eventually sending a human mission to Mars. Technologies will be developed, implemented, and matured during each step of the journey and the human-robotic team—astronauts working cooperatively with cutting-edge robots that assist on common tasks and perform duties that would be hazardous or impractical for the crew to perform—will be strengthened and improved.

This workshop —held just prior to the announcement of the new Vision— contributed to NASA's ongoing quest to transform space exploration through innovation and the thoughtful application of new and evolving technologies and processes. NASA plans to continue conducting exploration technology-focused workshops and technical interchange meetings to capture the broadest possible array of insights and expertise, learning from researchers in universities, national laboratories, NASA field centers, and industry to help better our future in space.

## Appendix A: List of Attendees

| <b>Name</b>              | <b>Affiliation</b> | <b>Telephone</b> | <b>Email</b>   |
|--------------------------|--------------------|------------------|--|
| Adams, Robert            | NASA               | 256/544-3464     | <a href="mailto:Robert.B.Adams@msfc.nasa.gov">Robert.B.Adams@msfc.nasa.gov</a>             |
| Barbastathis, George     | MIT                | 617/253-1960     | <a href="mailto:gbarb@mit.edu">gbarb@mit.edu</a>   |
| Batishchev, Oleg         | MIT                | 617/253-5799     | <a href="mailto:batish@mit.edu">batish@mit.edu</a>   |
| Bishop-Behel, Karen      | NASA               | 256/544-4235     | <a href="mailto:Karen.P.Bishop@nasa.gov">Karen.P.Bishop@nasa.gov</a>                       |
| Bryan, Terry             | MIT                | 617/253-8583     | <a href="mailto:tbryan@mit.edu">tbryan@mit.edu</a>   |
| Chan, Vincent            | MIT                | 617/253-2142     | <a href="mailto:chan@mit.edu">chan@mit.edu</a>   |
| Christensen, Carissa     | The Tauri Group    | 703/683-2883     | <a href="mailto:carissa.christensen@taurigroup.com">carissa.christensen@taurigroup.com</a> |
| Crawley, Ed              | MIT                | 617/253-7510     | <a href="mailto:crawley@mit.edu">crawley@mit.edu</a>                                       |
| Culpepper, Martin        | MIT                | 617/452-2395     | <a href="mailto:culpepper@mit.edu">culpepper@mit.edu</a>                                   |
| De Weck, Oli             | MIT                | 617/253-0255     | <a href="mailto:deweck@mit.edu">deweck@mit.edu</a>   |
| Duh, J.C.                | NASA               | 202/358-2225     | <a href="mailto:jcduh@nasa.gov">jcduh@nasa.gov</a>   |
| Geffre, Jim              | NASA               | 281/483-1336     | <a href="mailto:james.r.geffre@nasa.gov">james.r.geffre@nasa.gov</a>                       |
| Gershenfeld, Neil        | MIT                | 617/253-7680     | <a href="mailto:neilg@cba.mit.edu">neilg@cba.mit.edu</a>                                   |
| Gibson, Lorna            | MIT                | 617/253-7107     | <a href="mailto:ljgibson@mit.edu">ljgibson@mit.edu</a>                                     |
| Hoffman, Jeff            | NASA/MIT           | 617/452-2353     | <a href="mailto:jhoffma1@mit.edu">jhoffma1@mit.edu</a>                                     |
| Hoffman, Steve           | SAIC               | 281/483-9264     | <a href="mailto:stephen.j.hoffman1@jsc.nasa.gov">stephen.j.hoffman1@jsc.nasa.gov</a>       |
| Hofmann, Andreas         | MIT                |                  | <a href="mailto:hofma@mit.edu">hofma@mit.edu</a>   |
| How, Jonathan            | MIT                | 617/253-3267     | <a href="mailto:jhow@mit.edu">jhow@mit.edu</a>   |
| Howell, Joe              | NASA               | 301/286-8661     | <a href="mailto:Joe.Howell@nasa.gov">Joe.Howell@nasa.gov</a>                               |
| Iagnemma, Karl           | MIT                | 617/452-3262     | <a href="mailto:kdi@mit.edu">kdi@mit.edu</a>   |
| Jacobson, Stu            | MIT                | 617/253-2418     | <a href="mailto:sjacob@mit.edu">sjacob@mit.edu</a>   |
| Kadak, Andy              | MIT                | 617/253-0166     | <a href="mailto:kadak@mit.edu">kadak@mit.edu</a>   |
| Kamal, Jaffrey           | Delta Search Labs  | 617-551-4602     | <a href="mailto:kjaffrey@deltasearchlabs.com">kjaffrey@deltasearchlabs.com</a>             |
| Krezel, Jonathan         | NASA               | 202/358-1141     | <a href="mailto:jonathan.krezel@nasa.gov">jonathan.krezel@nasa.gov</a>                     |
| Leveson, Nancy           | MIT                | 617/258-0505     | <a href="mailto:leveson@mit.edu">leveson@mit.edu</a>                                       |
| Lozano, Paulo            | MIT                | 617/253-7485     | <a href="mailto:plozano@mit.edu">plozano@mit.edu</a>                                       |
| Mankins, John            | NASA               | 202/358-2818     | <a href="mailto:John.C.Mankins@nasa.gov">John.C.Mankins@nasa.gov</a>                       |
| Martinez-Sanchez, Manuel | MIT                | 617/253-5613     | <a href="mailto:mmart@mit.edu">mmart@mit.edu</a>   |
| Marzwell, Neville        | NASA               | 818/354-6543     | <a href="mailto:Marzwell@jpl.nasa.gov">Marzwell@jpl.nasa.gov</a>                           |
| McBride, Jim             | MIT                | 617/253-0185     | <a href="mailto:mcbride@media.mit.edu">mcbride@media.mit.edu</a>                           |
| Miller, Dave             | MIT                | 617/253-3288     | <a href="mailto:millerd@mit.edu">millerd@mit.edu</a>                                       |
| Modiano, Eytan           | MIT                | 617/452-3414     | <a href="mailto:modiano@mit.edu">modiano@mit.edu</a>                                       |
| Morin, Lee               | NASA               | 281/244-7970     | <a href="mailto:lee.m.morin@nasa.gov">lee.m.morin@nasa.gov</a>                             |
| Mullins, Carie           | The Tauri Group    | 724/449-6179     | <a href="mailto:carie.mullins@taurigroup.com">carie.mullins@taurigroup.com</a>             |
| Newman, Dava             | MIT                | 617/258-8799     | <a href="mailto:dnewman@mit.edu">dnewman@mit.edu</a>                                       |
| Palaia, Joe              | MIT                | 617/253-0864     | <a href="mailto:jpalaia@mit.edu">jpalaia@mit.edu</a>                                       |
| Patel, Raju              | MIT                | 617/253-4248     | <a href="mailto:rpatel@mit.edu">rpatel@mit.edu</a>   |
| Patteson, Sean           | MIT                | 617-864-8177     | <a href="mailto:spatter@mit.edu">spatter@mit.edu</a>                                       |
| Sarma, Sanjay            | MIT                | 617/253-1925     | <a href="mailto:sesarma@mit.edu">sesarma@mit.edu</a>                                       |
| Schindall, Joel          | MIT                | 617/253-3934     | <a href="mailto:joels@mit.edu">joels@mit.edu</a>   |
| Sedwick, Ray             | MIT                | 617/253-7831     | <a href="mailto:sedwick@mit.edu">sedwick@mit.edu</a>                                       |
| Slotine, Jean-Jacques    | MIT                | 617/253-0490     | <a href="mailto:jjs@mit.edu">jjs@mit.edu</a>   |
| Smitherman, David        | NASA               | 256/961-7585     | <a href="mailto:David.V.Smitherman@nasa.gov">David.V.Smitherman@nasa.gov</a>               |
| Suzuki, Nantel           | NASA               | 202/358-1728     | <a href="mailto:Nantel.H.Suzuki@nasa.gov">Nantel.H.Suzuki@nasa.gov</a>                     |
| Walz, Carl               | NASA               | 202/358-0357     | <a href="mailto:carl.walz-1@nasa.gov">carl.walz-1@nasa.gov</a>                             |

| <b>Name</b>     | <b>Affiliation</b>                    | <b>Telephone</b> | <b>Email</b>   |
|-----------------|---------------------------------------|------------------|--|
| Wegeng, Bob     | Pacific Northwest National Laboratory | 509/521-8244     | <a href="mailto:robert.wegeng@pnl.gov">robert.wegeng@pnl.gov</a> |
| Weiss, Katie    | MIT                                   |                  | <a href="mailto:weissk@mit.edu">weissk@mit.edu</a>               |
| Williams, Brian | MIT                                   | 617/253-1678     | <a href="mailto:williams@mit.edu">williams@mit.edu</a>           |
| Win, Moe        | MIT                                   | 617/253-9341     | <a href="mailto:moewin@mit.edu">moewin@mit.edu</a>               |
| Yarsky, Peter   | MIT                                   | 617/225-9800     | <a href="mailto:yarsky@mit.edu">yarsky@mit.edu</a>               |
| Young, Larry    | MIT                                   | 617/253-7759     | <a href="mailto:lry@mit.edu">lry@mit.edu</a>                     |
| Young, Pete     | MIT                                   | 617/253-5340     | <a href="mailto:pwyoung@mit.edu">pwyoung@mit.edu</a>             |

## REPORT DOCUMENTATION PAGE

*Form Approved*  
OMB No. 0704-0188

Public reporting burden for this collection of information is estimated to average 1 hour per response, including the time for reviewing instructions, searching existing data sources, gathering and maintaining the data needed, and completing and reviewing the collection of information. Send comments regarding this burden estimate or any other aspect of this collection of information, including suggestions for reducing this burden, to Washington Headquarters Services, Directorate for Information Operation and Reports, 1215 Jefferson Davis Highway, Suite 1204, Arlington, VA 22202-4302, and to the Office of Management and Budget, Paperwork Reduction Project (0704-0188), Washington, DC 20503

|  |   |   |  |
|--|---|---|--|
| <b>1. AGENCY USE ONLY</b> <i>(Leave Blank)</i>   | <b>2. REPORT DATE</b><br>March 2005                             | <b>3. REPORT TYPE AND DATES COVERED</b><br>Conference Publication |  |
| <b>4. TITLE AND SUBTITLE</b><br>MIT-NASA Workshop: Transformational Technologies   |   |   | <b>5. FUNDING NUMBERS</b>  |
| <b>6. AUTHORS</b><br>D.V. Smitherman, J. Hoffman,* R. Patel,* J.C. Mankins,**<br>C.B. Christensen,*** E.C. Gresham, A. Simmons,*** and C.A. Mullins***   |   |   |  |
| <b>7. PERFORMING ORGANIZATION NAME(S) AND ADDRESS(ES)</b><br>George C. Marshall Space Flight Center<br>Marshall Space Flight Center, AL 35812  |   |   | <b>8. PERFORMING ORGANIZATION REPORT NUMBER</b><br><br>M-1134              |
| <b>9. SPONSORING/MONITORING AGENCY NAME(S) AND ADDRESS(ES)</b><br>National Aeronautics and Space Administration<br>Washington, DC 20546-0001   |   |   | <b>10. SPONSORING/MONITORING AGENCY REPO NUMBER</b><br>NASA/CP-2005-213741 |
| <b>11. SUPPLEMENTARY NOTES</b><br>Prepared for the Future Concepts Office, Space Systems Programs/Projects Office<br>*Massachusetts Institute of Technology, **NASA Headquarters, ***The Tauri Group   |   |   |  |
| <b>12a. DISTRIBUTION/AVAILABILITY STATEMENT</b><br>Unclassified-Unlimited<br>Subject Category 18<br>Availability: NASA CASI 301-621-0390   |   |   | <b>12b. DISTRIBUTION CODE</b>  |
| <b>13. ABSTRACT</b> <i>(Maximum 200 words)</i><br>As a space faring nation, we are at a critical juncture in the evolution of space exploration. NASA has announced its Vision for Space Exploration, a vision of returning humans to the Moon, sending robots and eventually humans to Mars, and exploring the outer solar system via automated spacecraft. However, mission concepts have become increasingly complex, with the potential to yield a wealth of scientific knowledge. Meanwhile, there are significant resource challenges to be met. Launch costs remain a barrier to routine space flight; the ever-changing fiscal and political environments can wreak havoc on mission planning; and technologies are constantly improving, and systems that were state of the art when a program began can quickly become outmoded before a mission is even launched. This Conference Publication describes the workshop and featured presentations by world-class experts presenting leading-edge technologies and applications in the areas of power and propulsion; communications; automation, robotics, computing, and intelligent systems; and transformational techniques for space activities. Workshops such as this one provide an excellent medium for capturing the broadest possible array of insights and expertise, learning from researchers in universities, national laboratories, NASA field Centers, and industry to help better our future in space. |   |   |  |
| <b>14. SUBJECT TERMS</b><br>power and propulsion; communications; automation, robotics, computing, and intelligent systems; transformational techniques for space activities   |   |   | <b>15. NUMBER OF PAGES</b><br>44   |
|  |   |   | <b>16. PRICE CODE</b>  |
| <b>17. SECURITY CLASSIFICATION OF REPORT</b><br>Unclassified   | <b>18. SECURITY CLASSIFICATION OF THIS PAGE</b><br>Unclassified | <b>19. SECURITY CLASSIFICATION OF ABSTRACT</b><br>Unclassified    | <b>20. LIMITATION OF ABSTRACT</b><br>Unlimited                             |



National Aeronautics and

Space Administration

IS04

**George C. Marshall Space Flight Center**

Marshall Space Flight Center, Alabama

35812