

NASA/TM-2005-213913

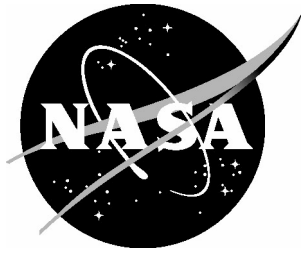

Thermal Structures Technology Development for Reusable Launch Vehicle Cryogenic Propellant Tanks

*Theodore F. Johnson, Roderick Natividad, H. Kevin Rivers, and Russell W. Smith
Langley Research Center, Hampton, Virginia*

September 2005

The NASA STI Program Office . . . in Profile

Since its founding, NASA has been dedicated to the advancement of aeronautics and space science. The NASA Scientific and Technical Information (STI) Program Office plays a key part in helping NASA maintain this important role.

The NASA STI Program Office is operated by Langley Research Center, the lead center for NASA's scientific and technical information. The NASA STI Program Office provides access to the NASA STI Database, the largest collection of aeronautical and space science STI in the world. The Program Office is also NASA's institutional mechanism for disseminating the results of its research and development activities. These results are published by NASA in the NASA STI Report Series, which includes the following report types:

- **TECHNICAL PUBLICATION.** Reports of completed research or a major significant phase of research that present the results of NASA programs and include extensive data or theoretical analysis. Includes compilations of significant scientific and technical data and information deemed to be of continuing reference value. NASA counterpart of peer-reviewed formal professional papers, but having less stringent limitations on manuscript length and extent of graphic presentations.
- **TECHNICAL MEMORANDUM.** Scientific and technical findings that are preliminary or of specialized interest, e.g., quick release reports, working papers, and bibliographies that contain minimal annotation. Does not contain extensive analysis.
- **CONTRACTOR REPORT.** Scientific and technical findings by NASA-sponsored contractors and grantees.

- **CONFERENCE PUBLICATION.** Collected papers from scientific and technical conferences, symposia, seminars, or other meetings sponsored or co-sponsored by NASA.
- **SPECIAL PUBLICATION.** Scientific, technical, or historical information from NASA programs, projects, and missions, often concerned with subjects having substantial public interest.
- **TECHNICAL TRANSLATION.** English-language translations of foreign scientific and technical material pertinent to NASA's mission.

Specialized services that complement the STI Program Office's diverse offerings include creating custom thesauri, building customized databases, organizing and publishing research results ... even providing videos.

For more information about the NASA STI Program Office, see the following:

- Access the NASA STI Program Home Page at <http://www.sti.nasa.gov>
- E-mail your question via the Internet to help@sti.nasa.gov
- Fax your question to the NASA STI Help Desk at (301) 621-0134
- Phone the NASA STI Help Desk at (301) 621-0390
- Write to:
NASA STI Help Desk
NASA Center for AeroSpace Information
7121 Standard Drive
Hanover, MD 21076-1320

NASA/TM-2005-213913

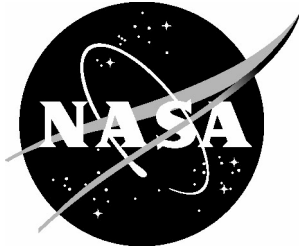

Thermal Structures Technology Development for Reusable Launch Vehicle Cryogenic Propellant Tanks

*Theodore F. Johnson, Roderick Natividad, H. Kevin Rivers, and Russell W. Smith
Langley Research Center, Hampton, Virginia*

National Aeronautics and
Space Administration

Langley Research Center
Hampton, Virginia 23681-2199

September 2005

The use of trademarks or names of manufacturers in the report is for accurate reporting and does not constitute an official endorsement, either expressed or implied, of such products or manufacturers by the National Aeronautics and Space Administration.

Available from:

NASA Center for AeroSpace Information (CASI)
7121 Standard Drive
Hanover, MD 21076-1320
(301) 621-0390

National Technical Information Service (NTIS)
5285 Port Royal Road
Springfield, VA 22161-2171
(703) 605-6000

Thermal Structures Technology Development for Reusable Launch Vehicle Cryogenic Propellant Tanks

Theodore F. Johnson*, Roderick Natividad⁺, H. Kevin Rivers^Δ, and Russell Smith**
NASA, Langley Research Center

Abstract

Analytical and experimental studies conducted at the NASA, Langley Research Center (LaRC) for investigating integrated cryogenic propellant tank systems for a reusable launch vehicle (RLV) are described. The cryogenic tanks are investigated as an integrated tank system. An integrated tank system includes the tank wall, cryogenic insulation, thermal protection system (TPS) attachment sub-structure, and TPS. Analysis codes are used to size the thicknesses of cryogenic insulation and TPS insulation for thermal loads, and to predict tank buckling strengths at various ring frame spacings. The unique test facilities developed for the testing of cryogenic tank components are described. Testing at cryogenic and high-temperatures verifies the integrity of materials, design concepts, manufacturing processes, and thermal/structural analyses. Test specimens ranging from the element level to the subcomponent level are subjected to projected vehicle operational mechanical loads and temperatures. The analytical and experimental studies described in this paper provide a portion of the basic information required for the development of light-weight reusable cryogenic propellant tanks.

INTRODUCTION

One of the goals for the next generation of space launch vehicles is an order of magnitude reduction in the cost of delivering a payload to orbit. Recent studies on space transportation by the National Aeronautics and Space Administration (NASA) [1, 2] indicate that a single-stage-to-orbit (SSTO) reusable launch vehicle (RLV), fueled by liquid hydrogen (LH₂) and liquid oxygen (LOx) has the potential to reach this goal. The recent X-33/RLV Program was a partnership between NASA and industry to create a viable RLV [3]. In this program, current and emerging technologies were utilized to develop and build the X-33, a 1/2 scale RLV demonstrator/test-bed vehicle [4]. These technologies were being pursued to develop an RLV that has efficient, and airline-like operation with 7-day refurbishment cycles between missions to reduce the operational costs, thereby reducing the cost to place a payload in orbit. One of the key technology drivers identified by this program was the use of reusable cryogenic tanks.

Large reusable cryogenic tanks will be required to contain the LH₂ and LOx for an SSTO RLV. Cryogenic tank development is critical for an RLV because the tanks may comprise as much as 70 to 80 percent of the volume of the vehicle, as shown in Figure 1 for two generic RLVs [1]. The development and fabrication of reusable cryogenic tanks is one of the significant

* Aerospace Engineer, Mechanics of Structures and Materials Branch, Mail Stop 188E, Hampton, VA 23681-2291, Theodore.F.Johnson@nasa.gov, (757) 864-5418, Member, AIAA.

⁺ Former Aerospace Engineer, Metals and Thermal Structures Branch, Mail Stop 396, Hampton, VA 23681-2291

^Δ Aerospace Engineer, Metals and Thermal Structures Branch, Mail Stop 396, Hampton, VA 23681-2291

** Aerospace Engineer, Metals and Thermal Structures Branch, Mail Stop 396, Hampton, VA 23681-2291

technical challenges to be overcome to develop an operable RLV [4]. Large expendable cryogenic tanks have been made for launch vehicles, but the durability of flight-weight reusable cryogenic propellant tanks has not been demonstrated. The cryogenic tanks of an RLV must not only function as pressure vessels at cryogenic temperatures, but they also must carry primary structural loads and support the thermal protection system (TPS). The cryogenic tanks, along with the TPS, must be easy to maintain, easy to repair, and reusable for the life of the vehicle.

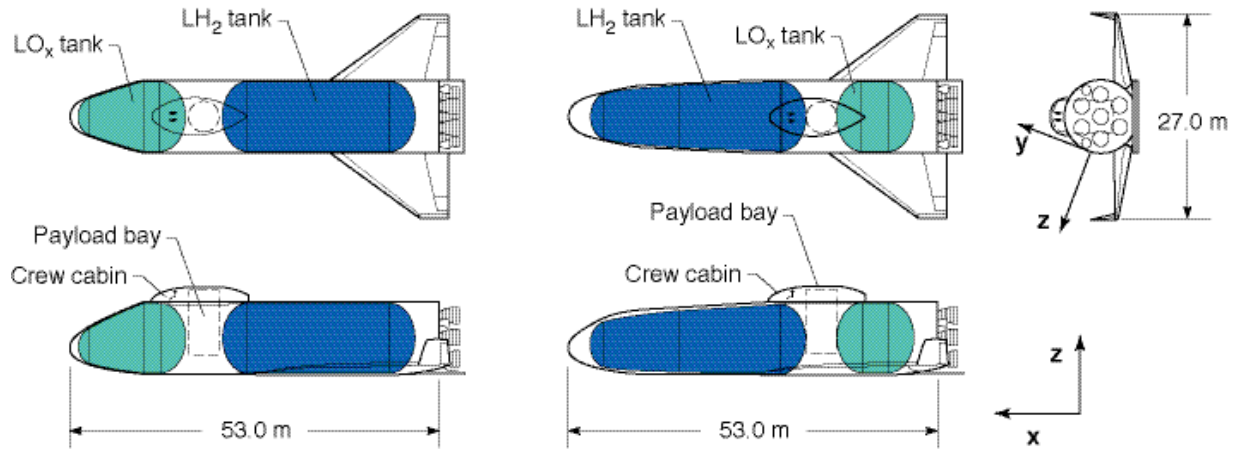

Figure 1. Generic RLV with an aft- or forward-located LH₂ tank.

In this paper, candidate reusable cryogenic propellant tank concepts are evaluated as a part of an integrated tank system that includes TPS, TPS attachment sub-structure, cryogenic insulation, and integrated vehicle health monitoring (IVHM) [5]. Thermal and structural analyses were used to compare several candidate combinations of cryogenic tanks and TPS. Combined thermal and mechanical tests of cryogenic insulation, adhesives, structural elements, and subcomponents were performed, with the thermal and mechanical loading becoming increasingly complex as the specimen size increased. Test environments included: temperatures ranging from 20 K (-423°F) to 810 K (1000°F), pressures ranging from atmospheric to 372 kPa (54 psig), and mechanical loads of uniaxial tension, compression, and biaxial tension. This paper describes integrated cryogenic tank analysis, testing, and test facilities development at the NASA, Langley Research Center (LaRC), which support technology development for a reusable LH₂ tank for an RLV.

ANALYTICAL STUDIES OF INTEGRATED CRYOGENIC SYSTEMS

The thermal and structural performance of the tank, cryogenic insulation, and TPS should be considered as a system to develop the best cryogenic tank for an RLV. Several combinations of LH₂ tank walls and TPS are analyzed to identify lightweight and thermally efficient concepts. An example of an integrated tank system design is displayed in Figure 2. The titanium (Ti) sandwich wall acts as a pressure vessel, cryogenic insulation, primary structure, and TPS support. Extra low interstitial (ELI) titanium is used to reduce hydrogen embrittlement. The exterior facesheet does not have to be impermeable to LH₂ or LOx thus, mechanical fasteners can penetrate the external facesheet to attach TPS. Gaskets beneath the TPS panel gaps prevent subsurface hot gas flow during re-entry.

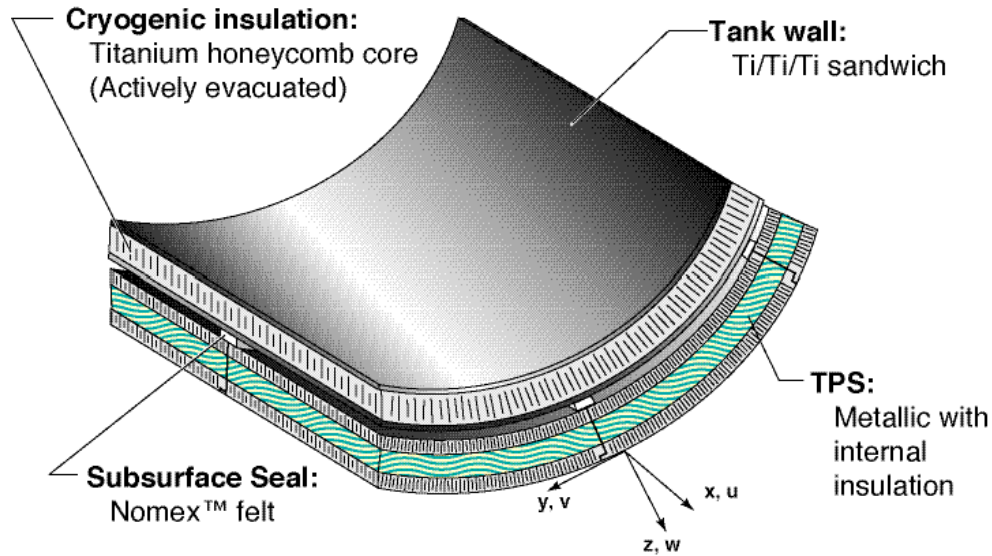

Figure 2. Example of an all-metallic Ti/Ti/Ti sandwich cryogenic tank with metallic TPS in an integrated tank system concept for a RLV.

Integrated tank concepts considered in the analytical studies are depicted in Figure 3 and listed in Table 1. The external foam concepts are based upon a forward-located, IM7/977-2 graphite-epoxy (Gr-Ep) ring and stringer stiffened tank concept from the X-33 Phase I Rockwell vehicle [6] that used adhesively bonded Rohacell™ as the cryogenic foam insulation and either alumina enhanced thermal barrier (AETB) or tailorable advanced blanket insulation (TABI) as the TPS. Honeycomb cryogenic insulation concepts consist of a sandwich tank wall with an evacuated core for insulation and superalloy/honeycomb (SA/HC) metallic panels as TPS. Several material combinations were considered for the honeycomb sandwich tank wall. The Aluminum 2219-T87 sandwich tank concept Al/Ti/Al was considered because aluminum is compatible with LH₂ and the titanium core can either be brazed or adhesively bonded to the aluminum facesheet. The titanium honeycomb core provides sufficient insulation if evacuated and enhances the structural stability of the tank. The concept with titanium facesheets and titanium honeycomb core was investigated because of the high strength and operation temperature (645 K, 700°F) of a brazed Ti/Ti/Ti concept. A concept consisting of IM7/5260 graphite-bismaleimide (Gr-BMI) facesheets with titanium honeycomb core was considered because Gr-BMI has a moderately high operating temperature (450 K, 350°F). In the final concept, Gr-BMI facesheets were combined with a Hexcel™ glass reinforced phenolic (HRP). The Gr-BMI/HRP/Gr-BMI concept has reduced thermal conductivity because of the non-metallic honeycomb core. Both Gr-BMI sandwich concepts can be adhesively bonded or co-cured sandwich structures. Thermal and structural analyses were used to compare the weights and strengths of these integrated tank systems. In the thermal analysis, the thicknesses of the cryogenic insulation and TPS insulation were sized to withstand the various operational temperatures. Thermal loading cases were from the ground-hold filling of the tanks, re-entry, and soak-through of heat energy after re-entry. In the structural analysis, the structural stability of the tank wall was investigated for a various concept with various ring frame spacings. The only mechanical loading used was compression axial line loading.

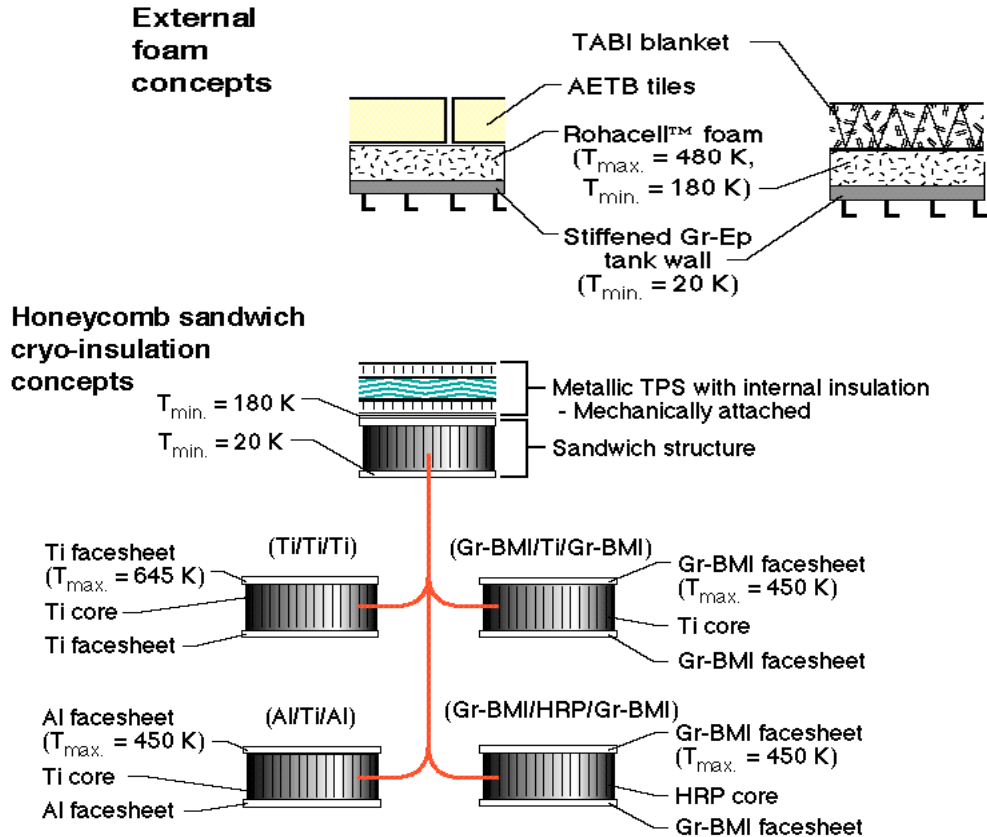

Figure 3. Concepts used in the thermal sizing and structural buckling studies.

Thermal Sizing Study

A thermal sizing study of the designs in Figure 3 was conducted to compare the thermal performance of each cryogenic tank concept. The cryogenic insulation thicknesses and TPS were sized to maintain temperatures within the limits shown in Figure 3 using a one-dimensional non-linear finite element sizing code called TPSSizer [7]. Temperature and pressure dependent material properties were obtained from industry and in reference [8]. The weight of the TPS and cryogenic insulation (honeycomb core for sandwich tank walls) was calculated and compared for each tank/TPS system. The thermal mass of the tank wall skin (sized to withstand the pressurization load and to limit LH₂ permeation in the case of composite walls) was included in the thermal sizing analysis. Based on reports from industry [9] and National Aerospace Plane (NASP) Program data, four to eight plies of Gr-Ep and Gr-BMI was required minimum thickness to resist hydrogen (H₂) permeation of a LH₂ tank.

TPSSizer Program

The TPSSizer program [7] uses an implicit, one-dimensional transient finite element formulation. Thermal properties may be a function of temperature and pressure and are updated at each time step. Radiation to space is assumed at the surface node, and the radiation vector is converged in an iterative fashion. These one-dimensional models include corrections for such things as coatings, adhesives, fasteners, and strain isolation pads. Detailed two-dimensional models have been used to varying degrees to validate the simplifications made in the one-dimensional models. Resizing of the TPS is accomplished through a repeated iterative procedure until all the temperature limits are satisfied within $\pm 2^{\circ}\text{F}$. At the beginning of each iteration, new

TPS and cryogenic insulation thicknesses are calculated based on the maximum temperatures computed in the previous analysis. Generally, only two to six sizing iterations are required. The cryogenic insulation is sized to satisfy two possible constraints. The first constraint, a ground hold condition, assumes that steady-state temperature conditions has been reached while the vehicle sits on the launch pad. The cryogenic insulation is sized to maintain a specified minimum temperature at the TPS to cryogenic insulation interface. By assuming steady-state temperature conditions, the sizing procedure is reduced to a simple equation based upon the TPS thickness. There is also iterative sizing of the cryogenic insulation based on the maximum transient temperature limit of the tank wall during re-entry/soak-through.

Table 1. Honeycomb sandwich cryogenic tank walls.

Facesheet/ core/ facesheet	Abbreviation
aluminum/ titanium/ aluminum	Al/Ti/Al
titanium/ titanium/ titanium	Ti/Ti/Ti
graphite-bismaleimide/ titanium/ graphite-bismaleimide	Gr-BMI/Ti/Gr-BMI
Hexcel™ glass reinforced phenolic/ graphite-bismaleimide	Gr-BMI/HRP/Gr-BMI

The criteria used for sizing the thickness of the cryogenic insulation and TPS were: a constant temperature of 20 K (-423°F) at the tank wall, prevention of frost build-up and air liquefaction on the cryogenic insulation surface of the tank during ground-hold, and limiting the maximum operational temperatures (shown in Figure 3) of the various materials used in the structure and TPS of the vehicle during re-entry. All of the sandwich tanks had a lower limit temperature of 115 K (-250°F) on the outer facesheet during ground-hold to minimize air liquefaction. The windward side heating load¹ was for the vehicles in Figure 1. An example of the heating load is shown in Figure 4. These cylindrical study vehicles were used because the vehicles did not have cavities over the cryogenic tanks or an aeroshell, thus the tank wall-insulation-TPS was layered as in Figure 2.

The mass of the cryogenic insulation and TPS are plotted in Figure 5 versus the x-location along the length of the windward centerline of the vehicle as defined in Figure 1. Although the LH₂ tank does not extend the entire length of the vehicle, the tank may be located either forward or aft as shown in Figure 1. An all-metallic concept, Ti/Ti/Ti with metallic TPS, is lighter than the other organic/ceramic or metallic concepts. The all-metallic titanium concept is lighter

¹ The windward side heating load was provided by Kay Wurster of the Vehicle Analysis Branch (VAB) at LaRC.

because the relatively high use-temperature of titanium requires less TPS for re-entry heating and the evacuated titanium honeycomb core acts as an effective insulator, eliminating the need for cryogenic insulation. The non-metallic core of the Gr-BMI/HRP/Gr-BMI concept has a reduced thermal conductivity that increased the insulative capacity compared to the metallic core specimens making this concept lighter than the other sandwich concepts except for the all-titanium concept. The Gr-BMI/HRP/Gr-BMI concept is also lighter than the stiffened Gr-Ep concepts because the outer facesheet can be allowed to cool to a temperature of 115 K (-250°F) during ground-hold. The upper use temperature limit and low heat capacity of the Rohacell™ (480 K, 400°F) external cryogenic foam increases the TPS thickness for the stiffened Gr-Ep structure making the concept heavier than the all titanium concept. The Al/Ti/Al and Gr-BMI/Ti/Gr-BMI tanks are the heaviest concepts. These two concepts do not effectively use the higher temperature capability of the titanium core because of the lower maximum operating temperature of the facesheets during re-entry. The aluminum concept is not included in the structural buckling study.

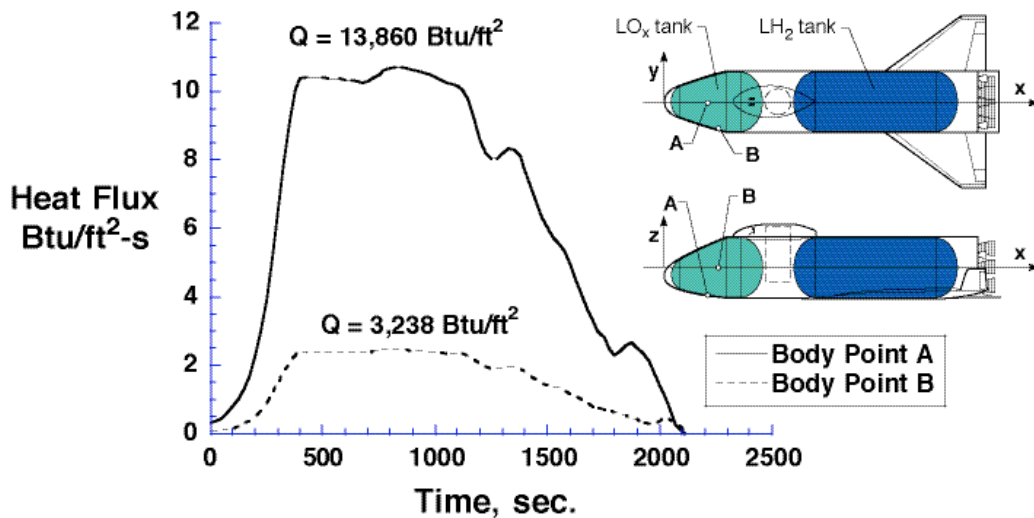

Figure 4. An example of the heat flux on the windward centerline and side of the generic vehicle for a LOx tank.

Structural Buckling Study

A structural buckling study was performed with the lightest weight tank concepts based on the thermal insulation weight identified in the thermal sizing study. The feasibility and cost of fabrication were not factors in the evaluation. The weight of the structural elements of the tank and the effects of varying ring frame spacing on tank stability were compared in the structural buckling study. This structural study focused on determining the axial buckling load of an unpressurized LH₂ tank under axial compression line loading, N_x , during the ground-hold and soak-through phase of a vehicle mission-profile. Pressure stabilization of the LH₂ tank was ignored to design a tank with sufficient strength to support a full LOx tank in the event of LH₂ tank depressurization. A non-linear, finite difference, shell-of-revolution code, BOSOR4 [10], was used as the analysis tool in the study.

BOSOR4 Program

The BOSOR4 program was based upon the Vlasov-Sanders shell theory and was used to conduct both non-linear pre-buckling and buckling analyses [11]. Modal iteration was used in

BOSOR4 to determine the eigenvalues. A representative model of a sandwich tank wall structure and the boundary conditions used in the analysis are shown in Figure 6. A detailed description of the boundary conditions and models can be found in reference [12]. The model had periodic boundary conditions simulating an infinitely long cylindrical tank. The ring frame design was kept fixed in this study to reduce the number of variables, but the ring frame spacing was varied for all of the models. The core thicknesses from the thermal sizing study were also used in the buckling models.

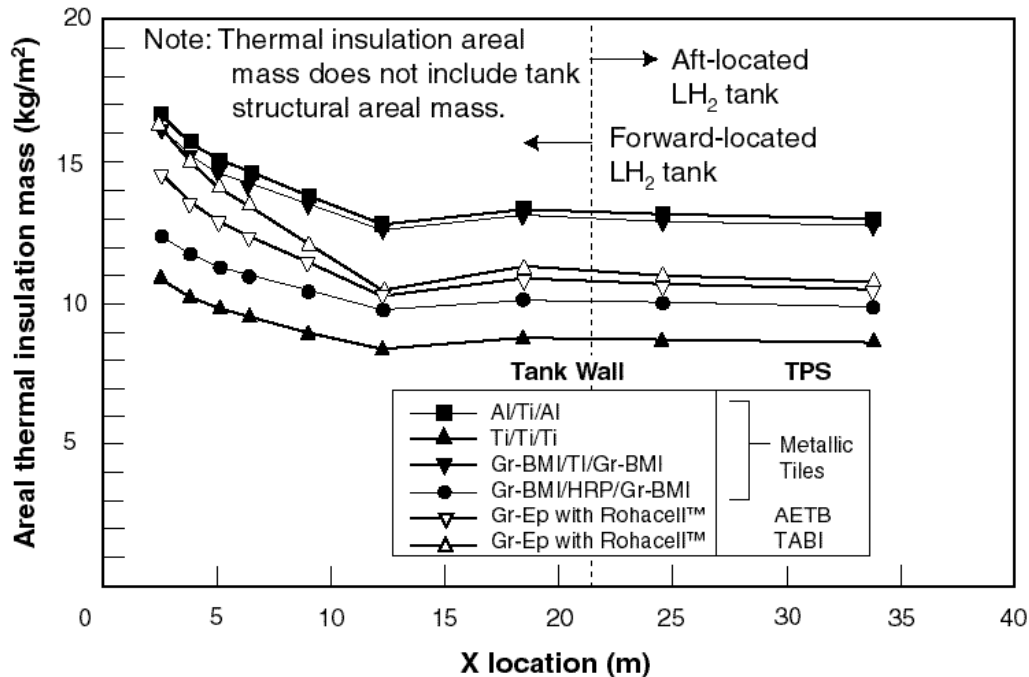

Figure 5. Areal masses of TPS and cryogenic insulation along the windward centerline of the generic vehicle for a LH₂ tank.

The concepts evaluated in the structural buckling study are Ti/Ti/Ti, Gr-BMI/HRP/Gr-BMI, and Gr-BMI/Ti/Gr-BMI sandwich concepts, and Gr-Ep ring and stringer stiffened tank concepts. The structural weight of the tank (not including the sandwich core material, cryogenic insulation or TPS), and the buckling strength of the tank are plotted using the ring frame spacing as the abscissa in Figure 7. The Gr-BMI/HRP/Gr-BMI concept was found to have the same buckling response and weight as the Gr-BMI/Ti/Gr-BMI concept and is not shown separately in Figure 7. The curve in Figure 7 for the Ti/Ti/Ti concept shows a reduction in buckling strength for a ring frame spacing less than 1.5 m (60 in.) because the buckling mode changes from panel buckling to local buckling in the ring frame. The Ti/Ti/Ti tank concept fails in a collapse mode at a low ring frame spacing, placing a high compression load in the ring frame. The other tank concepts all buckle between ring frames in a panel buckling mode.

An aft-located LH₂ tank, which does not rely on pressure stabilization, must be able to resist a minimum buckling load of 630 kN/m (3.6 kips/in.) due to the weight of a forward-located LOx tank and a payload during launch. A vehicle with a forward-located LH₂ tank does not experience the maximum axial compression load until after landing. The buckling load in this case is 300 kN/m (1.720 kips/in.) due to bending [13] when the vehicle is horizontal after landing in an unpressurized state.

All of the sandwich tank concepts will buckle well above all load requirements for an aft- or forward-located LH₂ tank at all ring frame spacings studied. The Gr-Ep ring and stringer stiffened tank is designed as a forward-located LH₂ tank and requires a 0.75 m (30 in.) ring frame spacing to resist a 300 kN/m (1.720 kips/in.) buckling load. The Ti/Ti/Ti tank at ring frame spacings greater than 1.5 m (60 in.) and a Gr-BMI/Ti/Gr-BMI tank at all ring frame spacings is lighter than a Gr-Ep ring and stiffened structure at a 0.75 m (30 in.) spacing. An aft-located, non-pressure-stabilized, Gr-Ep ring and stringer stiffened tank would weigh substantially more than the honeycomb tanks because of the additional structural mass required to resist buckling and inertial loads due to the weight of a forward-located LOx tank and the payload. Thus, the results shown in Figure 7 suggest that sandwich structures have a structural and weight advantage over stiffened Gr-Ep tanks.

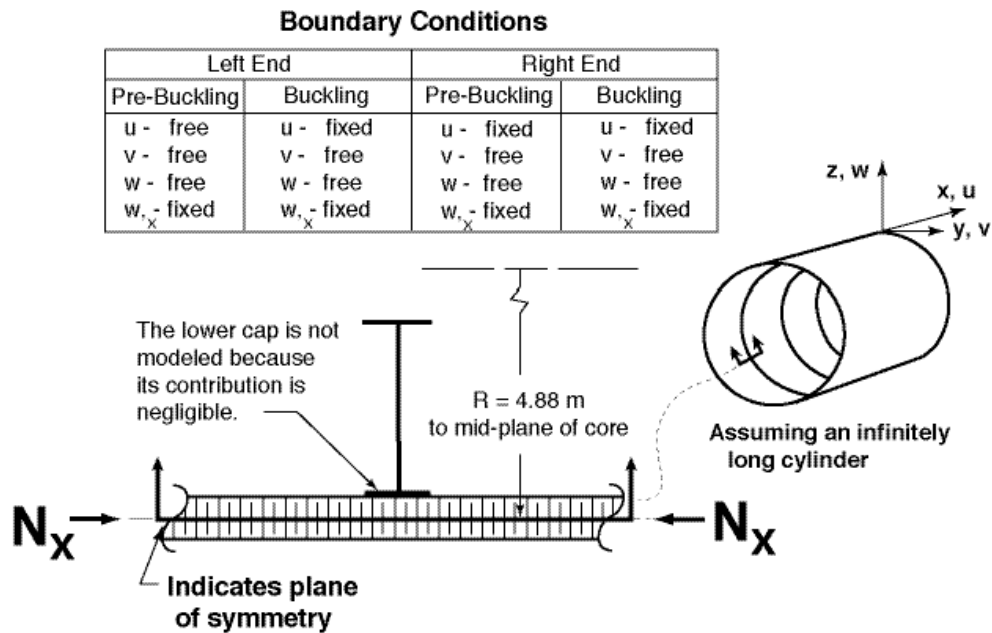

Figure 6. The boundary conditions, model orientation, and model used in BOSOR4 for the structural buckling study.

Combined TPS, cryogenic insulation, and tank structural areal masses are ranked by their total weight in Table 2. The studies demonstrate the advantages of sandwich structure in an integrated tank system design. Several sandwich tanks with metallic TPS and ring frame spacings of 3.0 m (120 in.) are lighter than the stiffened forward-located Gr-Ep concepts with ceramic TPS with a ring frame spacing of 0.75 m (30 in.). Sandwich tanks with larger ring frame spacings are not considered because of increased pressure pillowing. The lightest tank concept is the Gr-BMI/HRP/Gr-BMI concept with metallic TPS. An all-metallic Ti/Ti/Ti tank concept is the second lightest. Both concepts are not only lighter, but also have much higher buckling strengths than the Gr-Ep stiffened tank and have a weight advantage over Gr-Ep due to their higher operating temperatures. If the stiffened Gr-Ep forward-located tank is moved to an aft location, the structural mass of the tank would increase.

The thermal and structural studies indicate that a honeycomb sandwich tank with mechanically attached metallic TPS is an attractive LH₂ tank system for an RLV. However, more detailed studies are required to corroborate the results from the analytical studies and any

of the concepts studied will require verification of their insulative capacities, strengths, reliability, and durability through thermal, and structural testing.

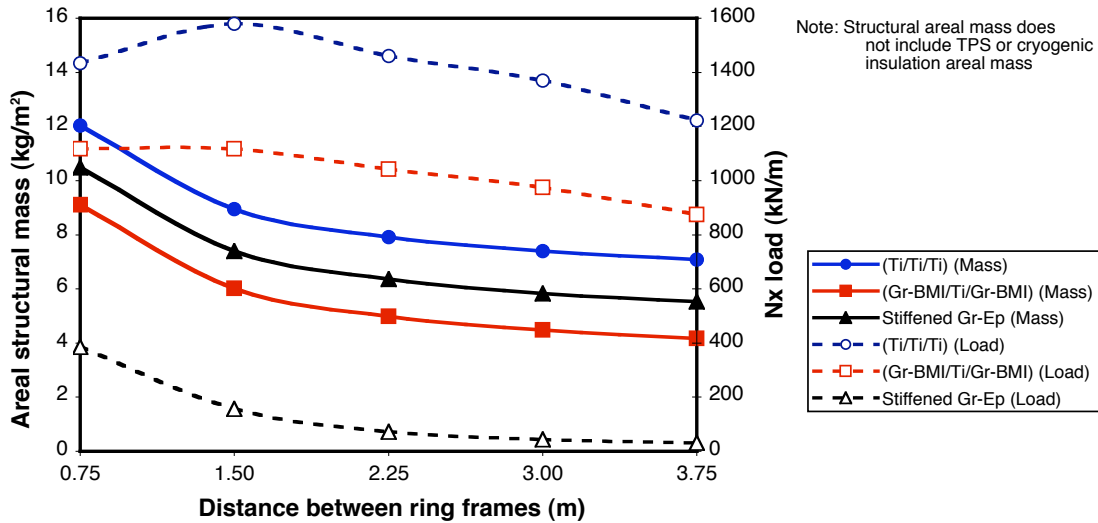

Figure 7. Structural buckling study results for areal masses and critical buckling loads for sandwich skin tanks and a forward-located.

Table 2. Combined areal masses from the thermal sizing and structural buckling studies with variable ring frame spacing.

Tank/ TPS	Ring frame spacing (m)	Cryogenic insulation & TPS areal mass (kg/m ²)	Tank structural areal mass (kg/m ²)	Total areal mass (kg/m ²)
(Gr-BMI/HRP/Gr-BMI)/ (SA/HC)	3.0	10	6.0	16.0
(Ti/Ti/Ti)/ (SA/HC)	3.0	8.9	8.9	17.8
(Gr-BMI/Ti/Gr-BMI)/ (SA/HC)	3.0	12.8	6.0	18.8
Stiffened Gr-Ep/ AETB	0.75	11.3	10.4	21.7
Stiffened Gr-Ep/ TAB1	0.75	11.7	10.4	22.1

TEST PROGRAM

A series of tests and test facilities have been developed during Phase I and Phase II of the NASA X-33/RLV Program to further evaluate potential reusable cryogenic tank designs for RLVs. These tests provide information to verify the performance of a concept, to validate analysis methods, and to demonstrate the scalability of a tank design. The specimens vary in size from small elements to large subcomponents. The element and panel testing were performed to investigate specific aspects of the integrated tank design such as bonding methods, evacuation

processes, cryogenic insulation integrity, and load carrying capability. Evaluating tank performance as an integrated tank system (tank structure, cryogenic insulation, and TPS) at operational temperatures and load conditions is critical to validate a design. Therefore, subcomponent testing of full-scale cryogenic tank sections under cyclic thermal and mechanical loading was performed to investigate additional thermal-structural interactions of the tank design and to validate performance and fabrication techniques. The cryogenic tank shown in Figure 8, illustrates the uniaxial tension and compression panel tests, the cryogenic pressure box subcomponent test, and the mechanical loading each test was designed to simulate. Each of the tests required the development of new, unique testing facilities and test procedures.

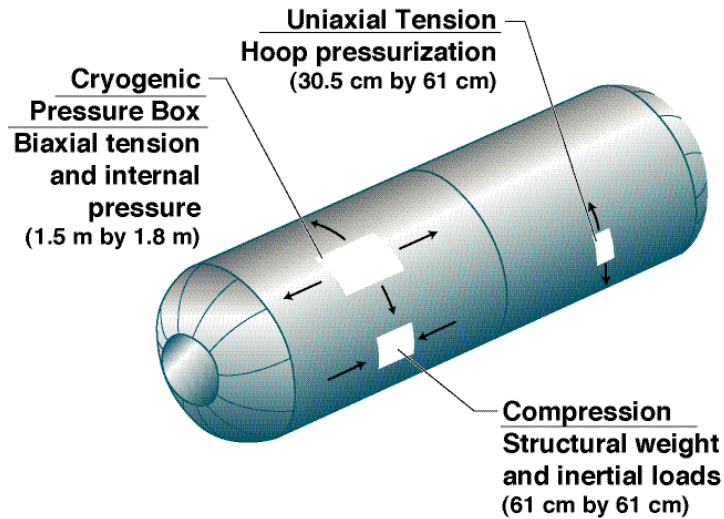

Figure 8. Panel and subcomponent ground tests (not to scale) and the load conditions the tests simulated for a cryogenic tank.

Element Tests

Element tests were developed to investigate specific design features under simplified load conditions to provide data that can be incorporated into the design of larger specimens. Two types of element tests were performed, the flatwise tension test and the sandwich core evacuation test or ravioli tests. In these tests, element specimens were cycled between temperatures of 20 K (-423°F) and 395 K (250°F). Flatwise tension tests investigated adhesive strengths after thermal cycling and sandwich evacuation tests investigated the feasibility of maintaining an evacuated core in a sandwich cryogenic tank wall.

Flatwise Tension Test

Adhesives were used to bond honeycomb core to composite facesheets and to bond cryogenic foam insulation to the tank wall. Flatwise tension tests [14] were used to investigate the effects of cryogenic and elevated temperatures on the bond line pull-off strengths for sandwich tank walls and tank walls with adhesively bonded cryogenic insulation. Examples of flatwise tension specimens are shown in Figure 9. When an adhesive is subjected to large changes in temperature, the adhesive may experience a phase transition, becoming brittle at low temperatures, and could be subject to stress relaxation or creep at elevated temperatures. A structural system subjected to large changes in temperature, may also develop high stresses induced by coefficient of thermal expansion mismatch resulting in debonding or core cracking without any mechanical load applied.

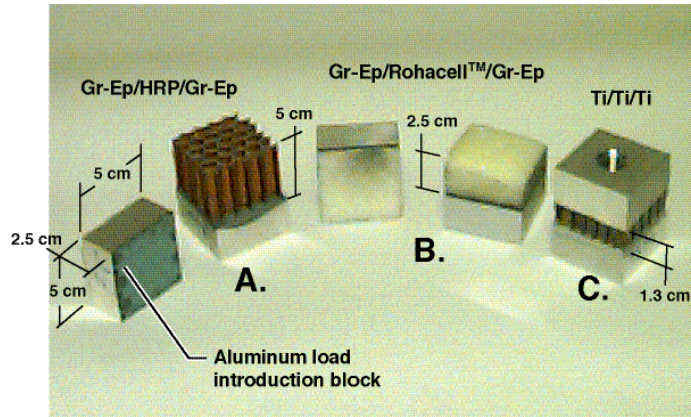

Figure 9. Flatwise tension specimens: A. Gr-Ep/HRP/Gr-Ep, B. Gr-Ep/Rohacell™/Gr-Ep, C. Ti/Ti/Ti.

The adhesive and facesheet/core combinations tested to date are listed in Table 3. Various types of adhesively bonded or co-cured 5.1 cm by 5.1 cm (2 in. by 2 in.) specimens were cycled from room temperature to cryogenic or elevated temperatures. Each specimen was then loaded to failure in tension at room temperature. In Figure 10, the ultimate stress results are displayed for HRP honeycomb bonded to Gr-Ep facesheets as an example of the type of information generated from the flatwise tension tests. The room-temperature specimens are control specimens which were not thermally cycled, providing a baseline strength for a specimen type. Full details of the flatwise tension tests results are reported by Glass [14]. The remaining specimens were either thermally cycled from room temperature to 20 K (-423°F) 10 times or from room temperature to 395 K (250°F) 10 times.

Table 3. Adhesives, facesheets, and core materials used in the flatwise tension tests.

Facesheet/Core	Adhesive					
	EA 9394	PR 1664	Crest 3170	FM 300	HT 435	Co-cure
Gr-Ep/						
Ti		✓	✓		✓	
HRP	✓	✓	✓	✓	✓	
Rohacell™ WF-71	✓	✓		✓	✓	
Nomex™	✓	✓		✓		
Gr-BMI/						
Ti		✓	✓		✓	
HRP						✓
Nomex™	✓			✓	✓	
Rohacell™ WF-71	✓			✓	✓	
Al/						
Ti	✓	✓	✓		✓	
Stainless Steel/						
Rohacell™ WF-71	✓	✓	✓			

The three best performing adhesives based on tests performed and reported by Glass [14] and as seen in Figure 10, were EA 9394, Crest 3170, and HT 435. The EA 9394 is a room-temperature-cured adhesive and is widely used as a cryogenic adhesive. The Crest 3170 is also a room-temperature-cured adhesive and is stronger than EA 9394 after thermal cycling. The HT 435 is a high-temperature-cured adhesive (450 K [350°F]) and had the best overall performance after being thermally cycled, however, this adhesive was the most sensitive to preparation procedures such as surface preparation, adequate pressure on the specimen during cure, and the correct cure temperature. The FM 300, a high-temperature-cured film adhesive (450 K [350°F]) had the lowest strength and the PR 1664, a room-temperature-cured adhesive, also had a relatively low strength.

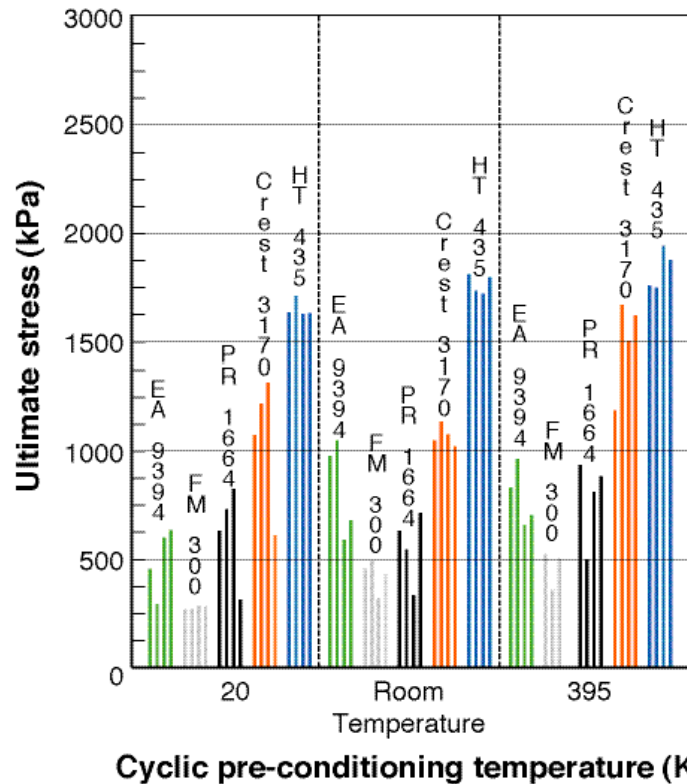

Figure 10. Flatwise tension strengths (tested at room temperature) of HRP honeycomb core bonded to Gr-Ep with five different adhesives and having three different pre-conditionings. Each bar represents a different specimen tested to failure.

Sandwich Core Evacuation (Ravioli) Test

The core of a cryogenic sandwich tank may not only perform its structural function, but if evacuated, may also act as cryogenic insulation. Evacuating the core enhances its insulation capacity by reducing the thermal effects of natural convection and gas conduction and may eliminate the need for additional cryogenic insulation. It is essential to maintain a vacuum in the core to prevent cryopumping and potential failure of the sandwich.

A test was developed to evaluate the ability of various concepts for a sandwich tank wall system to resist gas permeation [14]. A series of evacuated core honeycomb specimens, shown in Figure 11, were fabricated and tested. The specimens were referred to as ravioli specimens due to their shape. A square of cryogenic foam insulation or perforated honeycomb core

material with 45° beveled edges was sealed inside of a 15 cm by 15 cm (6 in. by 6 in.) shell of Gr-Ep or Gr-BMI. The specimen was sealed by either bonding the two pre-cured halves with an adhesive or by co-curing the shell material around the core. The core material in these specimens is perforated or drilled to allow for evacuation due to air liquefaction/solidification from cryogenic temperatures or by mechanical evacuation. An evacuation stem (location shown in Figure 11) was used to actively evacuate the specimen and allow any trapped gasses to escape as the specimen was warmed.

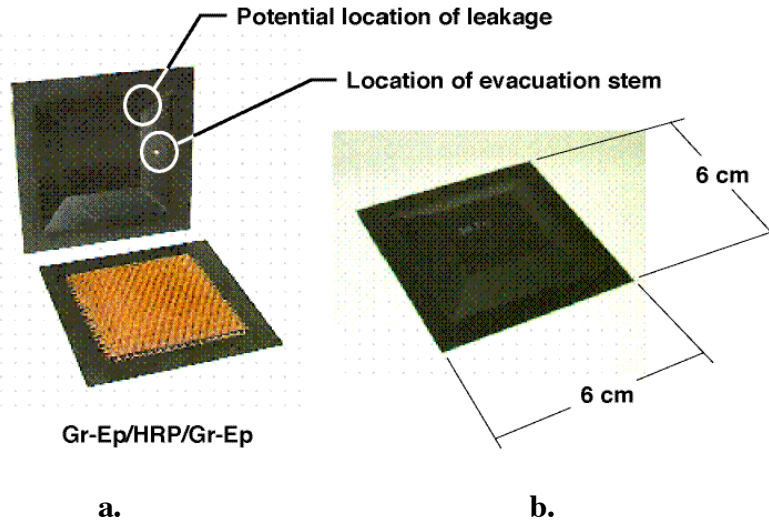

Figure 11. a.) The components of a Gr-Ep ravioli specimen with HRP honeycomb core and the b.) top view of assembled specimen (evacuation stem removed).

All six ravioli specimens tested are listed in Table 4. Specimen 1 had a Rohacell™ core, but did not have an evacuation stem. This specimen was cycled from room temperature to 80 K (-320°F) 10 times by immersing the specimen in a container filled with LN₂, removing the specimen, then allowing the specimen to warm to room temperature. There were no visible signs of damage by the naked eye. The specimen was also immersed once in liquid helium (LHe) and then removed. The specimen ruptured as it warmed to room temperature. It is believed that the specimen permeated LHe into the core region and burst because the LHe vaporized faster than the gaseous helium (GHe) could out-gas. Each specimen listed in Table 4, except for specimen 1, had an evacuation stem attached on the upper portion of the specimen to actively evacuate the specimen and to allow the specimen to out-gas if LHe permeated to the core region. The specimens were thermally cycled 10 times to LN₂ temperatures (80 K [-320°F]), then immersed 2 times in LHe (4K [-450°F]) with no visible signs of degradation. The integrity of each specimen was then investigated after thermal cycling by evacuating the specimen as the temperature of the specimen was lowered from ambient to 80 K (-320°F). At various temperatures, GHe was sprayed on the edges of the specimen while a helium (He) mass spectrometer leak detector was used to actively evacuate the specimen and detect the amount of leakage of GHe into the specimen. The data from two leak detection tests for specimen 6 are shown in Figure 12. The plot shows that as the specimen was cooled, the ability of the specimen to maintain a low pressure diminished. The leaks in specimens 2 through 5 were too large for the He mass spectrometer leak detector to evacuate the specimen.

Table 4. Gr-Ep ravioli specimens.

Specimen no.	Core Material	Adhesive	Result
1*	Rohacell™ WF-110	FM 300	Rupture
2	Rohacell™ WF-51	FM 300	Large leaks
3	Rohacell™ WF-71	PR 1664	Large leaks
4	Nomex™ honeycomb	Crest 3170	Large leaks
5	Rohacell™ WF-110	Co-Cured	Large leaks
6	HRP honeycomb	EA 9394	Moderate vacuum held

Note:

* No evacuation port

The results from the ravioli tests demonstrated that maintaining vacuum in even a small specimen is difficult, and as the specimen was cooled, its resistance to GHe permeation was reduced. The helium mass spectrometer leak detector could not localize the origin of GHe permeation. The GHe permeation into the specimens may have resulted from a coefficient of thermal expansion mismatch between the adhesive and the two halves of the specimen causing microcracks in the bond line. A crease located on the top of the shell at the corners, as indicated in Figure 11, may have also been a source of leakage. The co-cured specimen without an adhesive layer at the bond line performed only slightly better than the adhesively bonded specimens. These results suggest that improvements are needed in the fabrication of leak-free sandwich structures, and that a vented or an actively evacuated system may be required in an evacuated core sandwich structure.

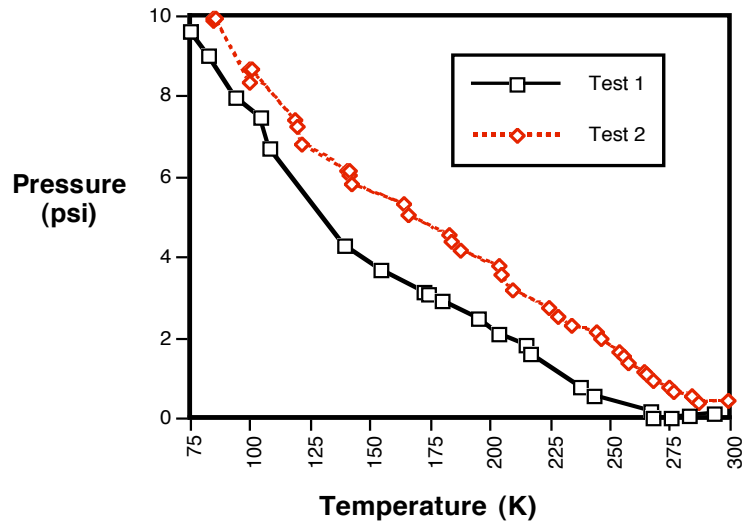

Figure 12. Pressure versus temperature for the 6th ravioli specimen.

Panel Tests

Panel tests were used to address integration issues between the tank wall and cryogenic insulation subjected to representative operational thermal and mechanical loads. The panel test specimens were larger than the element specimens and incorporated “lessons learned” from the element tests. Two types of panel tests are described: a cyclic uniaxial tension test to simulate hoop pressurization, and a static compression test to simulate structural and inertial loads, as

depicted in Figure 8. Cryogenic insulation was integrated into the specimen for the panel tests to reduce the complexity of testing. Testing with TPS attached to the specimen would require additional heating equipment and would have resulted in longer, more complicated testing cycles, and more expensive, elaborate test specimens.

Uniaxial Tension Tests

Combined cyclic thermal and mechanical tests of various cryogenic tank wall concepts were performed on flat 30.5 cm by 61 cm (1 ft by 2 ft) panel specimens. A flat specimen closely approximates a curved tank wall due to the large radius of the tank. These tests were developed from earlier tests of a cryogenic insulation tile developed for the Advanced Launch System (ALS) Program [15]. The purpose of the tests was to simulate both the thermal and mechanical loads experienced in an RLV mission from launch, to orbit, to re-entry. The cryogenic tanks in an RLV must endure biaxial tension loads associated with internal pressurization as well as maximum thermal and mechanical flight loads. However, for these tests, the only mechanical load applied was a uniaxial tension load simulating circumferential pressure loading. These combined, cyclic, thermal and mechanical tests verify: the durability of the cryogenic insulation when subjected to cyclic mission-profile conditions, the bond line integrity between cryogenic insulation and the structure, the performance of cryogenic tank fabrication technologies at a small scale, and the effectiveness of various IVHM techniques such as fiber optic (strain, temperature, and H₂ sensing) and acoustic sensors.

Specialized test fixtures were developed to operate between a minimum temperature of 20 K (-423°F) and a maximum temperature of 645 K (700°F). Figure 13 shows a typical specimen mounted in the fixture with the cryogenic chambers mounted on the surface of the inner tank wall of the specimen and a convective heating chamber adjacent to the external surface of the foam insulation. Tension load and temperatures for the cryogenic and high temperature chambers were independently controlled in a test cycle. A typical cycle lasted 30 to 80 minutes. An example of a thermal and mechanical load profile for a LH₂ tank specimen is shown in Figure 14, which displays the tension loading and temperature profiles on the hot side and cryogenic side of the panel over a period of time.

All of the panels tested as a part of the NASA X-33 Program Phase I and II are listed in Tables 5 and 6. Fiber-optic or IVHM thermal sensors were used on some of the panels tested (as indicated in Table 5). A meter of fiber-optic cable was coiled at several locations to obtain a point-wise thermal reading [5]. A single fiber was used to monitor several locations on a specimen. The adhesive methods and the ability of the fiber optic thermal sensors to operate during mission profile conditions were tested in the uniaxial tension tests. The tests of panels LO-3 and LO-4 support qualification of the SS-1171 spray-on-foam insulation (SOFI) for the Al LOx tank for the X-33.

Compression Test

The compressive load capability of a tank wall concept under simulated structural and inertial loads was tested using representative flat specimens in the cryogenic/high temperature compression test fixture shown in Figure 15. This fixture and the flat specimens was also used to induce a through-the-thickness temperature gradient in a compression specimen during a test.

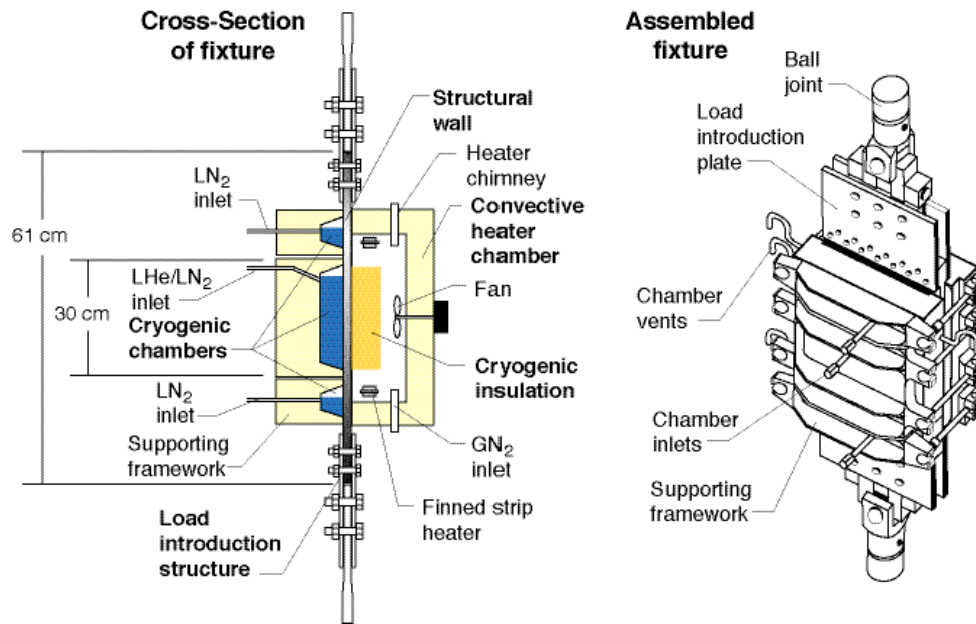

Figure 13. Schematic and assembled view of the test fixture for the uniaxial tension test.

Table 5. Experimental results for the LOx tank concepts subjected to combined thermal and mechanical tension load.

LOx tank panel	Panel description	No. of cycles	Results [†]
LO-1	Al-Li* panel, EA 9394 adhesive, external Airex™ foam insulation	23	No cracks in foam. No disbonds.
LO-2	Al panel, EA 9394 adhesive, external Airex™ foam insulation	33	No cracks in foam. No disbonds.
LO-3	Al panel, external SS-1171, and PDL-1034 foaminsulation	50	PDL-1034 cracked after 16 cycles. Insulation thickness reduced due to surface charring (no degradation in performance noticed). No cracks in foam.
LO-4	Al-Li* panel, external SS-1171 foam insulation, fiber-optics	50	Insulation thickness reduced due to surface charring (no degradation in performance noticed).

Note:

* Al-Li - Aluminum Lithium 2195

† Cracks were determined by visual inspection without die or microscope.

In the compression test, a 61 cm by 61 cm (2 ft by 2 ft) specimen with cryogenic insulation was subjected to a cryogenic temperature load before a compressive load was introduced. Two temperature conditions were attempted, a uniform temperature, and a constant temperature gradient through-the-thickness of the specimen. Three identical sandwich panels were tested to failure. Each panel experienced one of three temperature load conditions: cryogenic temperature gradient (with a minimum temperature of 20 K [-423°F] and maximum temperature of 115K [-

250°F), room temperature, and a uniform elevated temperature (maximum temperature of 480 K [400°F]).

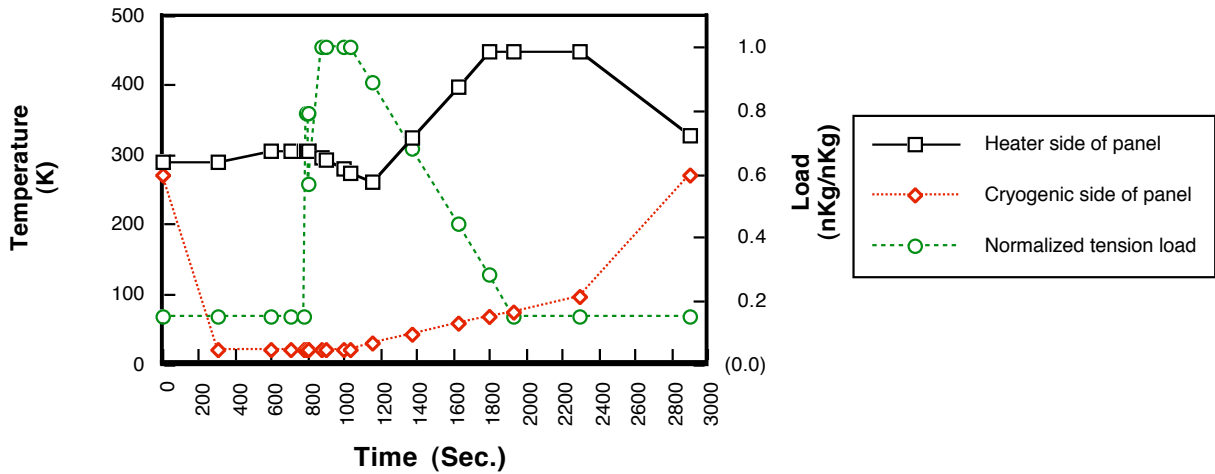

Figure 14. Typical combined thermal and mechanical cycle for a LH₂ tank specimen in the uniaxial tension test (load normalized to maximum load).

Table 6. Experimental results for LH₂ tank concepts subjected to combined thermal and mechanical tension load.

LH ₂ tank panel	Panel description	No. of cycles	Results
LH-1	Gr-Ep panel, EA 9394 adhesive, external Airex™ foam insulation	42	Airex™ foam cracked after 42 cycles (due to a void in the adhesive layer).
LH-2	K3B/Ti/K3B† co-cured sandwich panel	12	Panel failed in the load introduction region after 12 cycles.
LH-3	K3B/Ti/K3B† co-cured sandwich panel with a joint	0	Panel failed in the joint region at 80% of the design limit load during a pre-test load check.
LH-4	Gr-Ep/Rohacell™ WF-71/Gr-Ep foam sandwich panel	25	Facesheet separated from the foam core after 25 cycles (due to expansion of the foam with heat).
LH-5	Gr-Ep panel, EA 9394 adhesive, external Airex™ foam insulation, fiber-optics	50	No cracks. No disbonds.
LH-6	Gr-Ep panel, Crest 3170 adhesive, external Airex™ foam insulation, fiber-optics	50	No cracks. No disbonds.

Note:
† K3B - IM7/K3B.

The low-carbon, stainless steel (304 steel) compression load introduction fixtures shown in Figure 15 were developed to introduce a uniform axial load across the top and bottom edge of the panel without requiring potting of the ends of the specimen at cryogenic and elevated temperatures. These metallic fixtures were designed to control end displacement and to reduce

bending effects from through-the-thickness temperature gradients, thus providing controlled boundary conditions at various temperatures. Conventional potting materials soften at temperatures above 450 K (350°F) so their use was avoided. The metallic load introduction fixtures were designed to provide consistent and reproducible method of load transfer. Cryogenic and high temperature platens were developed to heat or cool the compression fixture to match the temperature of the specimen. Ceramic insulation tiles were used to reduce heat-loss through the platens and thermally isolate the compression fixture and platens from the load stand. Knife-edged supports (not shown Figure 15) composed of 304 steel were also developed to impose simple-support boundary conditions on the vertical edges of the test specimen. The knife-edged supports had a temperature range from 80 K (-320°F) to 480 K (400°F). A Crest 3170 bellows seal was developed to contain the cryogenic fluid on the cold side of the panel and resistive heater blankets were used to heat the faces of the panel.

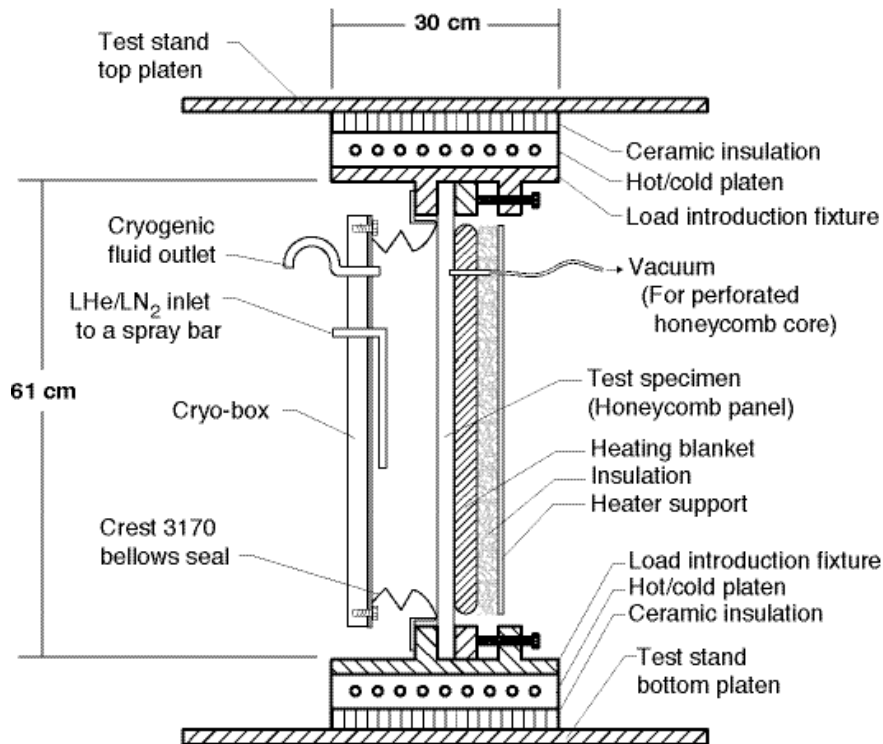

Figure 15. Schematic of the cryogenic/room/elevated temperature compression fixture.

Only the room-temperature panel test has been completed to date. The room-temperature honeycomb panel test consisted of co-cured IM7/K3B facesheets with a Ti honeycomb core Gr-K3B/Ti/Gr-K3B). The K3B resin is a thermoplastic material that has a maximum operational temperature of 480 K (400°F) and has non-autoclave joint fabrication potential. The upper and lower 0.06 m (2.5 in.) of the core were filled with a foaming adhesive during the curing process to facilitate load introduction from the fixture to the specimen and to prevent specimen “brooming” at the ends. However, the adhesive over-expanded in the core causing a discontinuity where the foam-filled region ended.

Finite element analysis at LaRC predicted that the room-temperature panel would buckle at a compressive load of 3,110 kN (699 kips) or 5,080 kN/m (29 kips/in.). Facesheet wrinkling was determined by the analysis to occur at an axial load of 707 kN (159 kips) or 1,160 kN/m (6.63

kips/in.). The panel failed at a compressive load of only 540 kN (121 kips) or 880 kN/m (5.04 kips/in.) in the upper section of the panel adjacent to the aforementioned skin discontinuity. Failure in this region suggested that either the load was not properly introduced into the panel through the foam-filled honeycomb core region or that the panel was poorly fabricated near the edge of the foam-filled honeycomb core.

Subcomponent Test

A new test facility, the Cryogenic Pressure Box (CPB) Test Facility, has been developed to validate full-scale tank subcomponents under realistic static and thermal/mechanical/pressure cyclical loading [16]. Curved tank panel concepts can be tested in this facility at a relatively low cost compared to a full-scale or scaled tank tests at cryogenic temperatures. Finite element analysis performed at LaRC predicts that the strain distributions developed during testing in the CPB will be similar to the strains seen in a full-sized cylindrical tank can be produced in a 0.75 m by 1.0 m (2.5 ft by 3.5 ft) region in the center of the specimen. The effects of cycling with mechanical loads, pressure loads, and thermal loads on full-scale assemblies of tank walls with cryogenic insulation, TPS, and IVHM can be determined with a full-scale subcomponent. Manufacturing and fabrication details can then be refined before fabrication of a full-scale tank, thus reducing the risk of premature failure in a tank due to cyclic thermal/mechanical loading.

A schematic section view of the CPB Test Facility is shown in Figure 16. A view of the chamber is shown in Figure 17. In this subcomponent test, a 1.5 m by 1.8 m (5 ft by 6 ft) curved (radii of 2.0 m to 6.5 m, 80 in. to 260 in.) panel in Figure 18 is loaded in biaxial tension by internal pressure and mechanical actuators. In addition, both cryogenic and elevated internal temperatures and an elevated external temperature can be applied. The biaxial tension load is introduced into the panel by internal pressure reacted through the load frame and by axial actuators. The maximum load applied by the axial actuators (not shown in Figure 16) is 2,000 kN (450 kips). Circumferential, or hoop, loads due to pressurization are induced by the reaction force from the load frame, through load introduction plates, into the test specimen.

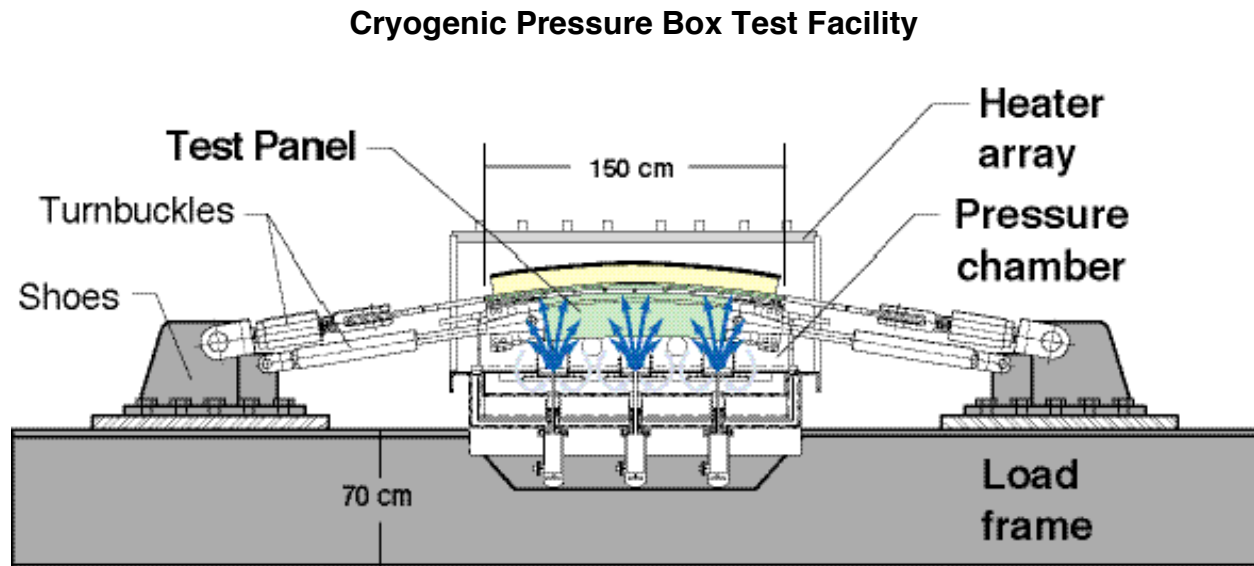

Figure 16. Schematic of the CPB Test Facility for subcomponent tests.

The vacuum jacketed pressure chamber can withstand internal pressures ranging from atmospheric to 372 kPa (54 psig) using GHe as the pressurization medium. The test panel and chamber can also be subjected to internal temperatures ranging from 395 K (250°F) to 20 K (-423°F) with the aid of twelve copper heat exchange towers that are encircled by copper coils that contain either LHe, GHe or LN₂. The GHe is recirculated by fans through the heat exchange towers. Helium does not liquefy at temperatures above 15 K (-430°F) and can be used to convectively cool the specimen and the CPB chamber. The heat exchange towers also have resistive heaters at their bases, enabling internal heating of the chamber and the internal surface of the panel to a maximum temperature of 395 K (250°F). A quartz-lamp heater array is used to heat the external surface of the specimen to a maximum temperature of 810 K (1,000°F). The heater array is flat and has eight symmetric zones that can be individually controlled to evenly heat specimens of various curvatures.

Cryogenic Pressure Box Chamber

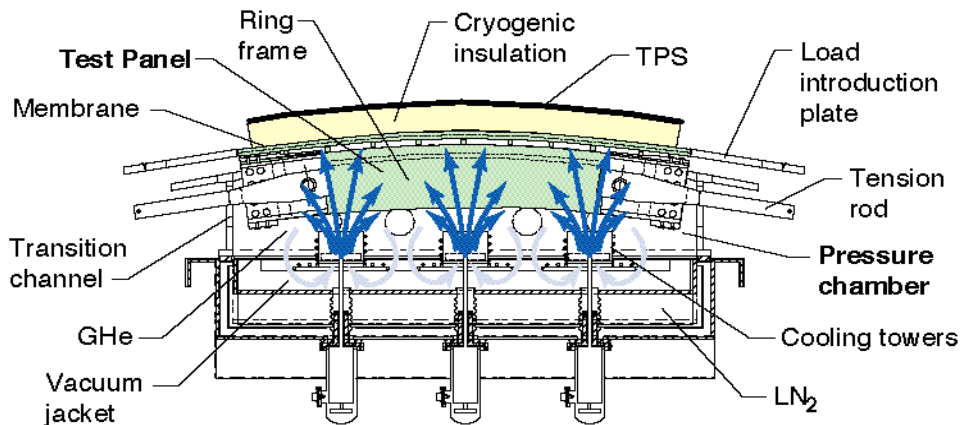

Figure 17. Schematic of the chamber of the CPB Test Facility.

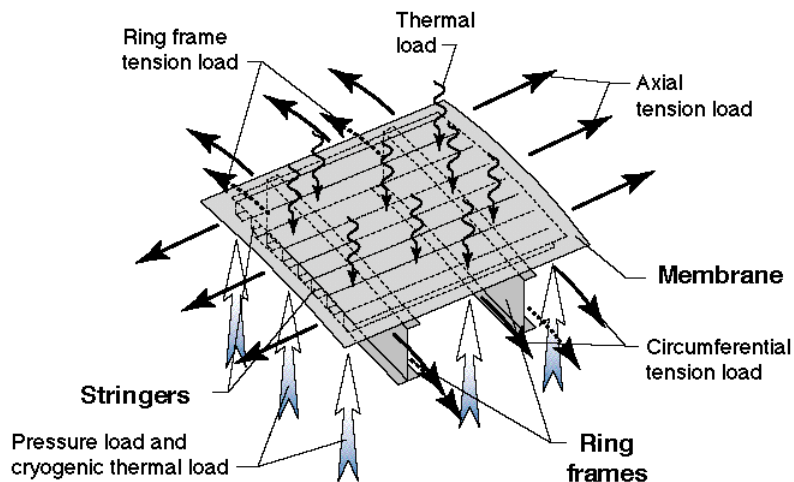

Figure 18. Thermal and mechanical loads applied to a representative specimen in the CPB Test Facility.

SUMMARY

A systematic approach was used in the research for the design of integrated cryogenic tank systems for a reusable launch vehicle (RLV). This approach began with thermal and structural analytical studies followed by testing of specimens ranging from elements to subcomponents at the NASA, Langley Research Center (LaRC).

The results of the analytical studies identified honeycomb sandwich tank with mechanically attached metallic thermal protection system (TPS) as a preferred approach for a reusable liquid hydrogen (LH₂) tank system for an RLV. The two most viable honeycomb sandwich concepts were found to be Gr-BMI/HRP/Gr-BMI and Ti/Ti/Ti, based on structural and thermal efficiency.

Element tests were used to evaluate bonding and fabrication methods as well as the evacuation process for sandwich tank structures. Adhesives such as Crest 3170 (now Lord 212) and HT 435 were identified as the most useful for cryogenic tank construction by the flatwise tension tests. The evacuated honeycomb sandwich (ravioli) tests demonstrated that sealed sandwich concepts may be problematic, that evacuation of a sandwich is difficult, and that active evacuation may be a solution to obtain a reliable sandwich tank concept.

The panel and subcomponent tests were developed to investigate structural strength and durability, the reliability of the fabrication process scale-up, thermal properties, and bond line integrity of cryogenic tank designs. The uniaxial tension tests provided data for the NASA X-33 Program in support of certifying SS-1171 for the liquid oxygen (LOx) tank and a new cryogenic foam insulation, Airex™, for the LH₂ tanks. The compression fixture will enable the testing of specimens at various temperatures or with through-the-thickness temperature gradients.

The unique analytical tools and facilities developed at the LaRC during Phase I and Phase II of the NASA X-33/RLV Program enable the study and testing of various cryogenic tank concepts at operational thermal loads, mechanical loads, and pressure loads. The results obtained from these analytical and experimental cryogenic tank studies will provide vital information required to develop full-scale, reusable, and integrated cryogenic tanks for future RLVs.

Acknowledgments

The research conducted at LaRC could not have been accomplished without the efforts of the members of the cryogenic tank team in the Metals and Thermal Structures Branch (MTSB). The cryogenic tank team was supported by systems specialists Mr. Joseph Sikora and Mr. Vincent LeBoffe, designer Mr. Kermit Jensen, structural analysts Mr. Carl Martin and Mr. Jeff Cerro and all of the technical staff in the MTSB laboratory but especially electrician Mr. Paul McClung for developing the control algorithms for the uniaxial tension tests. Optimization analyses was performed by Dr. Satchi Venkataraman and Dr. Raphael Haftka at the University of Florida. The Cryogenic Pressure Box Facility development was conducted with Dr. Damodar Ambur, Dr. David Glass, Mr. Marshall Rouse, Mr. Henry Wright, Mr. James Mayhew, and Mr. Carlos Perez. Many of the original concepts, analytical studies, and tests of the cryogenic tank team were initiated by Dr. Charles Camarda.

References

1. Freeman, Jr., D. C., Stanley, D. O., Camarda, C. J., Lepsch, R. A., Cook, S. A., "Single-Stage-To-Orbit-A Step Closer," Presented at the 45th Congress of the International Astronautical Federation (IAF), October 1994, IAF 94-V3.534.
2. NASA, "Access to Space Study Final Report," NASA Headquarters, Washington, D. C., July 1993.
3. Baumgartner, R. I., "Venturestar™ Single Stage to Orbit Reusable Launch Vehicle Program Review," Presented at the Space Technologies and Application International Forum, Albuquerque, NM, January 1997, Vol. 3: 1033-1039.
4. Cook, S., "The X-33 Advanced Technology Demonstrator," Presented at the American Institute of Aeronautics and Astronautics (AIAA) Dynamics Specialists Conference, Salt Lake City, UT, April 1996, AIAA-96-1195.
5. Melvin, L., Childers, B., Rogowski, R., Prosser, W., Moore, J., Froggatt, M., Allison S., Wu, M. C., Bly, J., Aude, C., Bouvier, C., Zisk, E., Enright, E., Cassadaban, Z., Reightler, R., Sirkis, J., Tang, I., Peng, T., Wegreich, R., Garbos, R., Mouyos, W., Aibel, D., Bodan, P., "Integrated Vehicle Health Monitoring (IVHM) for Aerospace Vehicles," Presented at the International Workshop on Structural Health Monitoring, Structural Health Monitoring: Current Status and Perspectives, Edited by Fu-Kuo Chang, Stanford, CA, September 1997, pp. 705-714.
6. Anonymous, "Prototype Tank Drawings and Analysis," Reusable Composite Hydrogen Tank System TA1 Payment Milestone 14, Part 2 of 5, Cooperative Agreement NCC8-39, Rockwell International, September 1995, SSD95D0388.
7. Myers, D. E. Martin, C. J., Blosser, M. L., "Parametric Weight Comparison of Advanced Metallic, Ceramic Tile, and Ceramic Blanket Thermal Protection Systems (TPS)," NASA Technical Memorandum 2000-210289, June 2000.
8. Williams, S. D., Curry, D. M., "Thermal Protection Materials: Thermal Property Data," NASA Reference Publication 1289, December 1992.
9. Robinson, M. J., "Composite Cryogenic Propellant Tank Development," Proceedings of the 35th AIAA/ASME/ASCE/AHS/ASC Structures, Structural Dynamics and Materials Conference, Hilton Head, SC, April 1994.
10. Bushnell, D., "BOSOR4: Program for Stress and Vibration of Shells of Revolution," Structural Mechanics Software Series, Edited by N. Perrone and W. Pilkey, University Press of Virginia, Charlottesville, VA, Vol. 1: 11-143.
11. Bushnell, D., "Stress, Stability and Vibration of Complex Shells of Revolution: Analysis and User's Manual for BOSOR4," NASA CR-2115, Oct. 1972.
12. Johnson, T. F., and Card, M. F., "Effects of Stiffening and Mechanical Load on Thermal Buckling of Stiffened Cylindrical Shells," AIAA Paper 95-1317, 36th AIAA/ ASME/ ASCE/ AHS/ ASL Structures, Structural Dynamics and Materials Conference, New Orleans, LA, April 1995.
13. Anonymous, "Test Report of Element/Subcomponent Testing," Reusable Composite Hydrogen Tank System TA 1 Payment Milestone 16, Part 1 of 2, Cooperative Agreement NCC8-39, Rockwell International, November 1995, SSD95D0507.
14. Glass, D. E., "Bonding and Sealing Evaluations for Cryogenic Tank," NASA Contractor Report 201734, August 1997.

15. McAuliffe, P. S., Davis, R. C., Taylor, A. H., "Development of Reusable, Flight-Weight Cryogenic Foam Insulation System," Presented at the American Institute of Aeronautics and Astronautics (AIAA) Space Systems Technology Conference, June 1986, AIAA-1189-CP.
16. Ambur, D. R., Sikora, J., Maguire, J. F. Winn, P. M., "Development of Pressure Box to Evaluate Reusable Launch-Vehicle Cryogenic Tank Panels," Presented at the American Institute of Aeronautics and Astronautics (AIAA) 37th AIAA/ASME/ASCE/AHS/ASC Structures, Structural Dynamics, and Materials Conference, Salt Lake City, Utah, April 1996, AIAA-96-1640.

Nomenclature

304 steel:	Stainless Steel	LH ₂ :	Liquid Hydrogen
AETB:	Alumina Enhanced Thermal Barrier	LHe:	Liquid Helium
Al:	Aluminum 2219-T87	LOx:	Liquid Oxygen
Al-Li:	Aluminum 2195	NASA:	National Aeronautics and Space Administration
ALS:	Advanced Launch System	NASP:	National Aerospace Plane
ELI:	Extra Low Interstitial	Nx:	Axial Load
Gr-BMI:	IM7/5260 Graphite-Bismaleimide	RLV:	Reusable Launch Vehicle
Gr-Ep:	IM7/977-2 Graphite-Epoxy	SA/HC:	Superalloy/Honeycomb
GHe:	Gaseous Helium	SOFI:	SS-1171 Spray On Foam Insulation
H ₂ :	Hydrogen	SSTO:	Single-Stage-To-Orbit
He:	Helium	TABI:	Tailorable Advanced Blanket Insulation
HRP:	Hexcel™ glass Reinforced Phenolic	Ti:	Titanium
IVHM:	Integrated Vehicle Health Monitoring	TPS:	Thermal Protection System
K3B:	IM7/K3B	MTSB:	Metals and Thermal Structures Branch
LaRC:	NASA, Langley Research Center	VAB:	Vehicle Analysis Branch

REPORT DOCUMENTATION PAGE				Form Approved OMB No. 0704-0188	
<p>The public reporting burden for this collection of information is estimated to average 1 hour per response, including the time for reviewing instructions, searching existing data sources, gathering and maintaining the data needed, and completing and reviewing the collection of information. Send comments regarding this burden estimate or any other aspect of this collection of information, including suggestions for reducing this burden, to Department of Defense, Washington Headquarters Services, Directorate for Information Operations and Reports (0704-0188), 1215 Jefferson Davis Highway, Suite 1204, Arlington, VA 22202-4302. Respondents should be aware that notwithstanding any other provision of law, no person shall be subject to any penalty for failing to comply with a collection of information if it does not display a currently valid OMB control number.</p> <p>PLEASE DO NOT RETURN YOUR FORM TO THE ABOVE ADDRESS.</p>					
1. REPORT DATE (DD-MM-YYYY)		2. REPORT TYPE		3. DATES COVERED (From - To)	
01- 09 - 2005		Technical Memorandum			
4. TITLE AND SUBTITLE Thermal Structures Technology Development for Reusable Launch Vehicle Cryogenic Propellant Tanks				5a. CONTRACT NUMBER	
				5b. GRANT NUMBER	
				5c. PROGRAM ELEMENT NUMBER	
6. AUTHOR(S) Johnson, Theodore F.; Natividad, Roderick; Rivers, H. Kevin; and Smith, Russell W.				5d. PROJECT NUMBER	
				5e. TASK NUMBER	
				5f. WORK UNIT NUMBER 23-064-20-32	
7. PERFORMING ORGANIZATION NAME(S) AND ADDRESS(ES) NASA Langley Research Center Hampton, VA 23681-2199				8. PERFORMING ORGANIZATION REPORT NUMBER L-19165	
9. SPONSORING/MONITORING AGENCY NAME(S) AND ADDRESS(ES) National Aeronautics and Space Administration Washington, DC 20546-0001				10. SPONSOR/MONITOR'S ACRONYM(S) NASA	
				11. SPONSOR/MONITOR'S REPORT NUMBER(S) NASA/TM-2005-213913	
12. DISTRIBUTION/AVAILABILITY STATEMENT Unclassified - Unlimited Subject Category 15 Availability: NASA CASI (301) 621-0390					
13. SUPPLEMENTARY NOTES An electronic version can be found at http://ntrs.nasa.gov					
14. ABSTRACT Analytical and experimental studies conducted at the NASA, Langley Research Center (LaRC) for investigating integrated cryogenic propellant tank systems for a reusable launch vehicle (RLV) are described. The cryogenic tanks are investigated as an integrated tank system. An integrated tank system includes the tank wall, cryogenic insulation, thermal protection system (TPS) attachment sub-structure, and TPS. Analysis codes are used to size the thicknesses of cryogenic insulation and TPS insulation for thermal loads, and to predict tank buckling strengths at various ring frame spacings. The unique test facilities developed for the testing of cryogenic tank components are described. Testing at cryogenic and high-temperatures verifies the integrity of materials, design concepts, manufacturing processes, and thermal/structural analyses. Test specimens ranging from the element level to the subcomponent level are subjected to projected vehicle operational mechanical loads and temperatures. The analytical and experimental studies described in this paper provide a portion of the basic information required for the development of light-weight reusable cryogenic propellant tanks.					
15. SUBJECT TERMS Cryogenic testing; Cryogenics; Sizing studies					
16. SECURITY CLASSIFICATION OF:			17. LIMITATION OF ABSTRACT	18. NUMBER OF PAGES	19a. NAME OF RESPONSIBLE PERSON
a. REPORT	b. ABSTRACT	c. THIS PAGE			STI Help Desk (email: help@sti.nasa.gov)
U	U	U	UU	28	19b. TELEPHONE NUMBER (Include area code) (301) 621-0390