

An Overview of the James Webb Space Telescope (JWST) Project

Authors:

Phillip A. Sabelhaus, JWST Project Manager 301-286-5712 phil.sabelhaus@nasa.gov
NASA, Goddard Space Flight Center, Code 443, Greenbelt, Md. 20771 Fax: 301-286-5558

**Doug Campbell, Mark Clampin, John Decker, Matt Greenhouse, Alan Johns, Mike Menzel,
Robert Smith, Pam Sullivan, NASA GSFC.**

ABSTRACT

The JWST project at the GSFC is responsible for the development, launch, operations and science data processing for the James Webb Space Telescope. The JWST project is currently in phase B with its launch scheduled for August 2011. The project is a partnership between NASA, ESA and CSA. The U.S. JWST team is now fully in place with the selection of Northrop Grumman Space Technology (NGST) as the prime contractor for the telescope and the Space Telescope Science Institute (STScI) as the mission operations and science data processing lead. This paper will provide an overview of the current JWST architecture and mission status including technology developments and risks.

Keywords: James Webb; Space Telescope; JWST; Hubble; HST

MISSION IN BRIEF

Primary Mirror

6.5 Meter Class, Segmented, Actively Controlled, 40° Kelvin nominal temperature

Wavelength Range

0.6 to 28 μm

Instruments

Near-Infrared Multi-Object Spectrometer

Near-Infrared Camera

Near-Infrared Tunable Filter Camera

Mid-Infrared Camera/Spectrometer

Payload Mass

Approximately 6,800 kg, 13,600 lbs. (Includes the payload adapter)

Launch Vehicle

Ariane V Expendable Launch Vehicle

Orbit

Lagrange Point 2 (1.5-million km or 940,000 miles from Earth)

Mission Length

5 years (10 year goal)

1. INTRODUCTION

The James Webb Space Telescope was conceived as a follow-on mission to the highly successful Hubble Space Telescope to allow scientists to see the first generations of stars.

Equipped with a large 18-segment, 6.5-meter primary mirror and a suite of revolutionary, infrared-sensing cameras and spectrometers, JWST will allow us to see younger objects in space than is currently possible with Hubble and help us analyze the minuscule specks of light that Hubble cannot detect. These nascent stars and galaxies are so distant that by the time their light reaches us, it has stretched into the longer, redder wavelength bands that are invisible to the human eye.

Consequently, no one has ever observed this cosmic “dark zone” before because they did not have the tools to do so. But with this “first light machine,” we will finally see what the universe looked like when it was merely a fraction of its current age and size, when the first stars and galaxies were just beginning to take form and ignite. In addition to conducting this unprecedented science, JWST will demonstrate revolutionary new technologies needed for future Origins missions. For this reason, the National Academy of Science has ranked JWST as one of NASA’s top science goals for this decade.

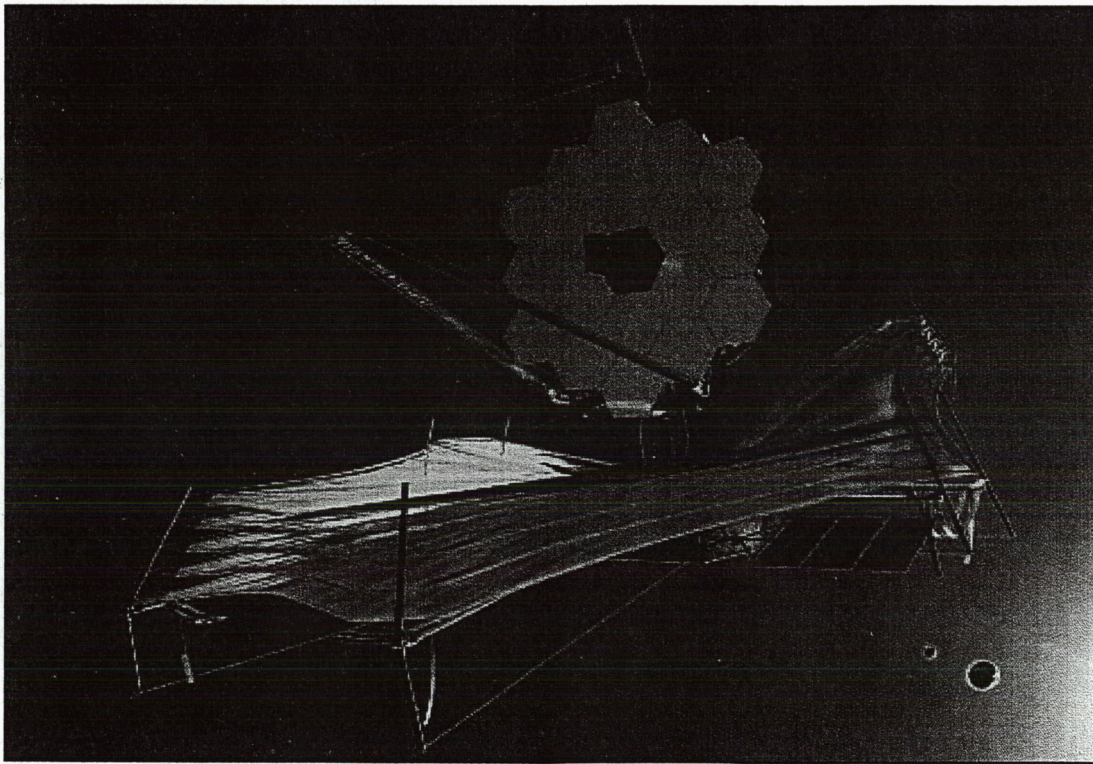

Figure 1. The James Webb Space Telescope

2. ADDITIONAL SCIENTIFIC GOALS

In addition to observing these young galaxies, JWST will tackle four other major objectives over the course of its 5-10 year lifetime. It will help determine the geometry of the universe, its age and determine its ultimate fate. A few years ago, two teams of astronomers rocked the scientific world by finding evidence that the expansion of the universe is accelerating rather than slowing down because of the gravitational attraction between the matter within it. Their observations seemed to confirm the existence of a new form of energy that causes the expansion of the universe to accelerate. JWST is capable of studying this phenomenon.

Although mission engineers designed the spacecraft to primarily peer at the farthest reaches of the universe, it will also look closer to home. With JWST, scientists can study the history of the Milky Way and its nearby neighbors by studying the old stars and star remnants that formed over the galaxy’s lifetime. Astronomers will use JWST to

study star birth and formation. Its infrared sensors can pierce the dust and gas that surround stellar nurseries and reveal the processes that dictate the mass and composition of stars, as well as the production of heavy elements. And last, NASA designed JWST to study the origin and evolution of planetary systems like our own. JWST may be able to directly detect large, Jupiter-sized planets around nearby stars. Although we cannot image smaller planets directly, JWST's high resolution will make it possible to see how planetary systems behave especially when they are in the process of formation, which will give us a more accurate picture of their evolution.

JWST's Four Scientific Themes

- The First Light After the Big Bang
- The Assembly of Galaxies
- Birth of Stars and Planetary Systems
- Planetary Systems and the Origins of Life

Technological Challenges At-A-Glance

1. A 6-meter-class, lightweight, cryogenic deployable, actively controlled with diffraction limited performance at a 2 micron wavelength.
2. A tennis court-sized deployable sunshield to passively cool the telescope and instruments to 40 degrees Kelvin providing sensitivity to extremely faint infrared photons.
3. A highly capable Observatory that weighs 6,800 kg, including the telescope and instruments.
4. Low-noise, large-area infrared detectors.
5. A cryogenic programmable slit mask for multi-object spectroscopy.

3. ORBITAL CONSIDERATIONS

JWST's orbit — at the second Lagrange Point (L2), located 1.5-million km (940,000 miles) from the Earth in the anti-Sun direction is perfect for this mission. The L2 orbit offers a thermally stable environment. At the L2 point, JWST will be in orbit around the Sun rather than the Earth, as it is with HST. This arrangement will allow JWST to live in the shadow of a giant sunshield, which deploys on orbit. In this shadow, the JWST can passively cool the instruments to below 40° Kelvin (about 400° below zero Fahrenheit) and the telescope optics to below 50° Kelvin. Although passive cooling represents an old concept, NASA has never flown a mission before that uses this method to reach these extreme temperatures. (As a reference, WMAP (at L2) uses passive cooling to reach about 95° Kelvin)

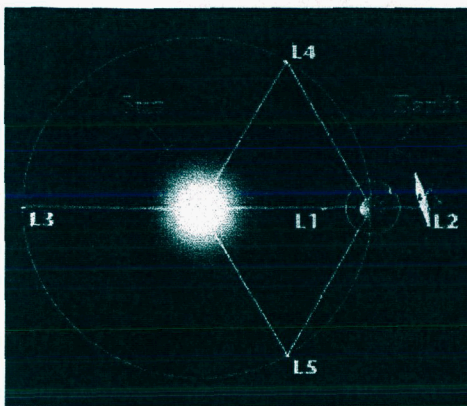

The Sun, Earth and Moon will always be on the same side of the telescope making it easier for the sunshield to keep light and heat away from the telescope cooling it to the very low temperatures required to prevent the telescope's own heat radiation from exceeding the brightness of the distant astronomical objects.

Figure 2. The Second LaGrange Point

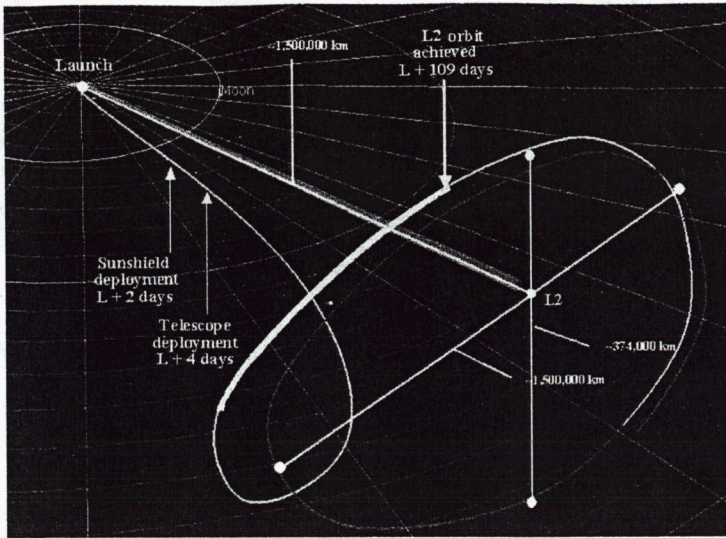

JWST will remain in this orbit due to the gravitational pull on L2 and occasional station-keeping maneuvers.

Figure 3. JWST Launch Trajectory

4. CRYOGENIC COOLING

To observe the farthest reaches of the universe, temperature is an essential consideration. JWST cannot achieve the needed sensitivity in the near- to mid-infrared spectrum if the telescope were not cooled to at least $\sim 40^\circ$ Kelvin. At warmer temperatures the instrument sensors would be swamped by infrared light emitted by the telescope itself.

5. SUNSHIELD TECHNOLOGY

JWST will passively cool to its cryogenic operating temperature by using a system of radiators shaded by the highly efficient tennis court sized sunshield shown in Figure 4. Separating and thermally isolating the warm spacecraft components to the sun side of the shield via a deployable isolation tower further enhance passive cooling. Power dissipation estimates on the cryogenic side of the observatory are judiciously monitored and allocations are stringently held to less than 300 milli-Watts. The mid-Infrared instrument will utilize a mechanical cooler to further cool its detectors to less than 7 Kelvin.

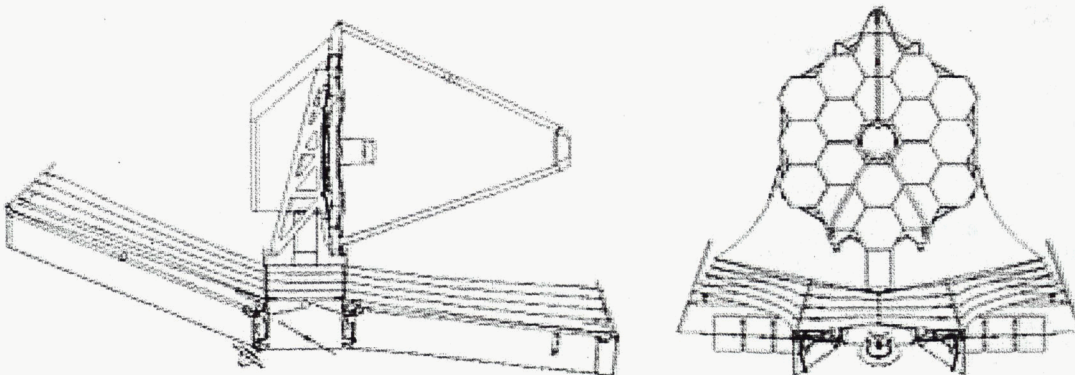

Figure 4. JWST Sunshield Configuration

6. COLD MIRRORS AND MOTORS

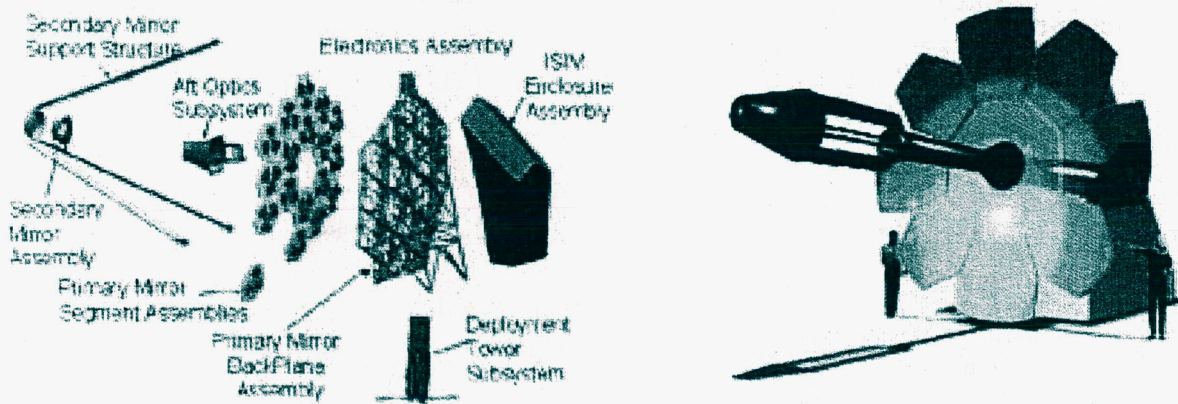

Figure 5. JWST Optical Telescope Element

One of the challenges for the JWST team is to design and manufacture lightweight mirrors and an active mirror control system to enable the best possible scientific return by providing diffraction limited performance for all wavelengths greater than 2 microns.

Even more technologically demanding than the deployable sunshield is JWST's segmented, 6.5-meter lightweight, deployable mirror, which will do what no other space-borne mirror has done. It will use a combination of small, ultra-precise actuators and sophisticated computer algorithms to align and properly figure the mirror. Developing such a technology is no small task — especially considering the added challenge of making JWST's primary mirror with six times the collecting area of Hubble's with more than a factor of 9 lower areal density (kg/m^2). In contrast, Hubble's 2.4-meter primary mirror is a single piece of polished glass weighing 180 kg per square meter. Although the segmented approach using lightweight materials accomplishes the performance objectives and allows the telescope to fit inside a commercial rocket fairing, it complicates the task of making sure the mirror achieves and holds its proper shape.

JWST's architecture requires that the optical system wavefront errors be measured and then corrected while the spacecraft is on orbit. A perfect mirror is not required at launch, and any changes due to stress as a result of rocket vibrations, or the deployment and the cool-down to the extremely cold operating temperature can be corrected. The Hubble's well-known spherical aberration has given the scientific community a great deal of experience in determining an optical system's wavefront error using images in a process called phase diverse phase retrieval. Image-based phase retrieval is the technique of choice for JWST, and is the front half of the full wavefront sensing and control process.

Once in orbit, JWST will take several images of stars as part of wavefront error sensing that begins the process of aligning the mirrors. With those images, ground controllers will use sophisticated computer algorithms to determine the level of distortion in the mirror segments caused by the super-cold temperatures, misalignments and fabrication errors. Ground controllers will correct the calculated distortion by activating computer-controlled mechanical actuators that move and deform the mirror segments until they are perfectly aligned and shaped. Their goal is to reduce the RMS magnitude of these distortions to no more than 0.15 microns, 300 times smaller than the width of a human hair (for reference, HST's distortion - The outer edge of the mirror was ground too flat by a depth of 4 microns (roughly equal to one fiftieth the thickness of a human hair). These actuators need to work in extremely cold temperatures, which adds another level of diligence to the engineering task. This on-orbit

wavefront sensing and control now under development at NASA and the prime contractor will undoubtedly find applications in other NASA and Defense Department missions.

Northrop Grumman has chosen the beryllium-based mirror technology made by Ball Aerospace & Technologies Corporation as the primary mirror material for JWST.

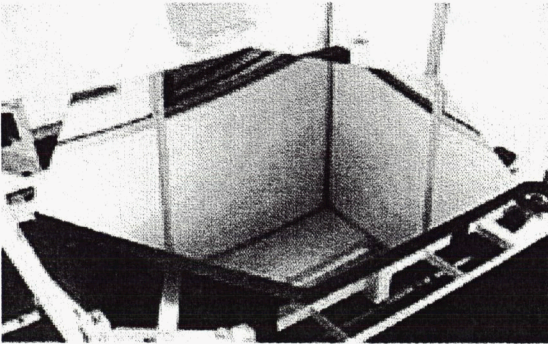

- 1.318m point-to-point light-weighted beryllium semi-rigid mirror
- 13.4 kg/m² beryllium substrate areal density
- 19.3kg/m² areal density for mirror system including mirror, reaction structure, flexures, actuators

Figure 6. JWST Hexagonal Mirror Segment

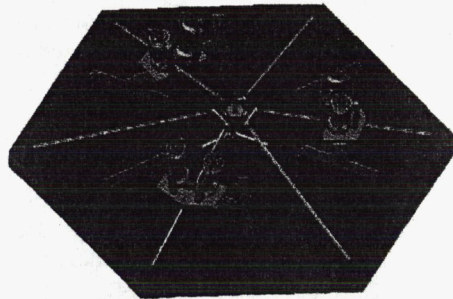

Figure 7. Backside of Primary Mirror Segment Assembly

Ball Aerospace of Boulder, Colorado will develop the semi-rigid primary mirror design they pioneered in NASA's Advanced Mirror System Development (AMSD) program. With its seven actuators, this mirror design has enough degrees of freedom to provide on-orbit correction. In addition to AMSD, a beryllium primary mirror is in use on the Spitzer Space Telescope ((formerly known as the Space Infrared Telescope Facility (SIRTF)), providing NASA flight experience with meter-sized beryllium mirrors.

7. INTEGRATED SCIENCE INSTRUMENT MODULE

The telescope will carry four instruments and an ultra-precise fine guidance sensor – the Near Infrared Camera (NIRCam), the Near Infrared Spectrograph (NIRSpec), the Tunable Filter near-infrared camera (FGS-TF), the Mid Infrared Instrument (MIRI), and the Fine Guidance Sensor. The Near Infrared Camera (NIRCam) development team is led by the University of Arizona. This instrument will be JWST's primary imager in the wavelength range of 0.6 to 5 microns. Required by many of the core science goals, the instrument is particularly well suited for detecting the first light-emitting objects that formed after the Big Bang. It is designed for multi-filter broad-band photometry and will be equipped with a coronagraph, which will enable imagery of debris disks, like our own Kuiper Belt, and massive giant planets around nearby stars. The NIRCam also serves as the wavefront sensor for the JWST telescope assembly. Image data collected by NIRCam at regular intervals will be used to diagnose the telescope's wavefront errors and update the positions of the mirror actuators. NIRCam is currently in Phase C with fabrication of most components for the Engineering Test Unit well underway.

The multi-object Near Infrared Spectrograph (NIRSpec) is provided by the European Space Agency. This instrument will serve as the principal multi-object spectrograph in the 0.6- to 5-micron wavelength range. Its ability to obtain simultaneous spectra of more than 100 objects in a 9-square arc-minute field of view at spectral resolutions of $\lambda/\Delta\lambda = 100, 1000, \text{ and } 3000$ enables high survey efficiency for a variety of compact sources including primordial galaxies.

The Tunable Filter camera, provided by the Canadian Space Agency, enables extended objects at any redshift to be imaged with diffraction limited angular resolution at $\lambda/\Delta\lambda = 100$. This instrument is critical for emission line surveys of primordial galaxies and detailed morphological studies of galaxy nuclei and Galactic nebulae.

The Mid Infrared Instrument, provided by an international collaboration of agencies led by the Jet Propulsion Laboratory and the United Kingdom Advanced Technology Center, will provide broad-band imaging and integral field spectroscopy over the 5 to 28 micron spectrum. This instrument will study the creation of the first heavy elements and will reveal the evolutionary state of high redshift galaxies. It is uniquely capable of studying the very early stages of star and planet formation, in regions where all visible light is blocked by dust and most of the emission is radiated at mid-infrared wavelengths.

The Fine Guidance Sensor, also provided by the Canadian Space Agency, will ensure the telescope can precisely point to a few milli-arcseconds and find very faint guide stars for at least 95% of all desirable scientific observations.

JWST's ISIM features two groundbreaking technologies — large-format detectors for all three instruments and a programmable spectrometer aperture mask (micro shutters) for the Near-Infrared Spectrograph. They are vital for carrying out the projects rigorous scientific program

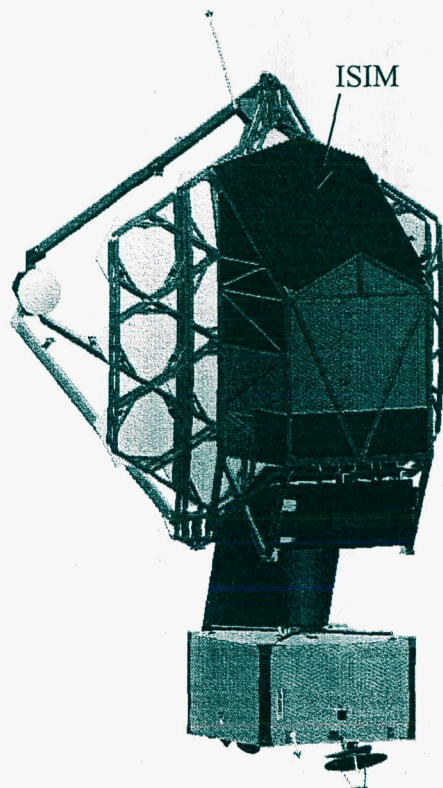

All four instruments and the guider are packed into a special module that will form the heart of JWST. This Integrated Science Instrument Module (ISIM) provides the structure, thermal environment, control electronics and data handling for the science instruments and fine-guidance sensor.

Figure 8. Integrated Science Instrument Module (ISIM) (sunshade omitted)

12. MISSION OPERATIONS

Mission operations are conducted through the JWST ground system shown in Figure 15, which includes the Deep Space Network (DSN), NASA Integrated Services Network (NISN), Goddard Space Flight Center's Flight Dynamics Facility (FDF) and the Science and Operations Center (S&OC). The S&OC is responsible for operating the Observatory, and is being developed and staffed by the Space Telescope Science Institute. The S&OC enables the planning and execution of scientific investigations. The remainder of the ground segment enables tracking and communications, housekeeping, and maintenance of the Observatory.

The JWST architecture has driven the design of the ground system architecture. JWST is designed to operate autonomously on orbit at the L2 for extended periods of time through the incorporation of event-driven, rather than time-driven, activity management. This will permit 8-hour per day, 5-day per week staffing of the S&OC for most operations.

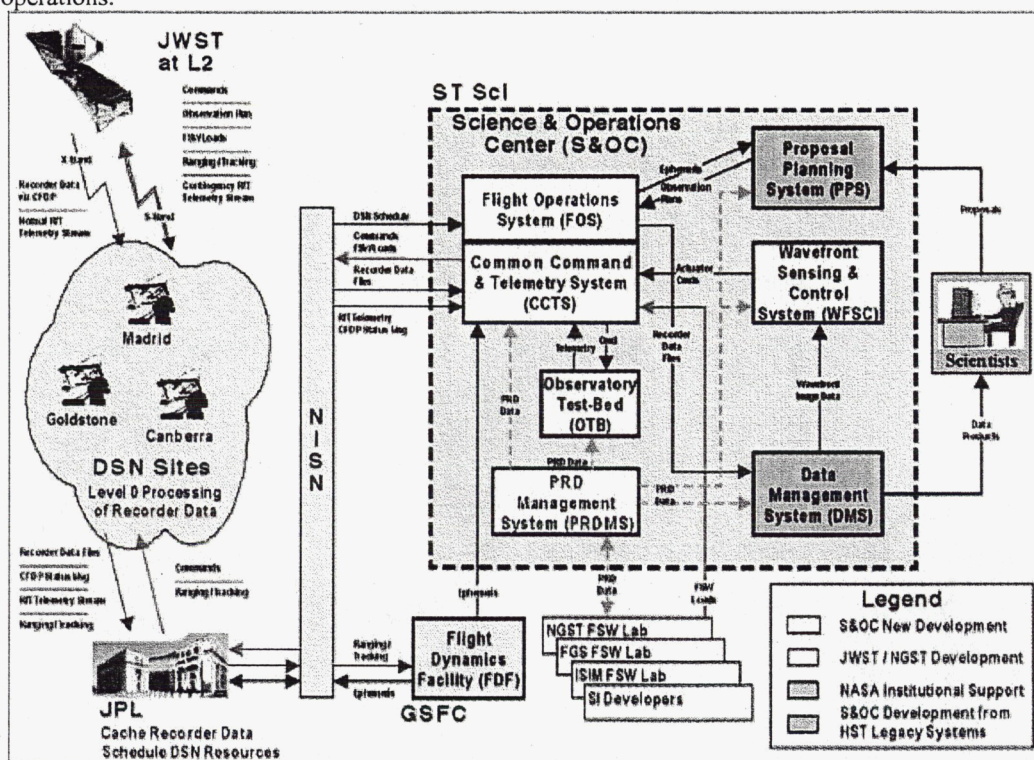

Figure 15. JWST Mission Operations Block Diagram

13. CONCLUSION

JWST is the National Academy of Science's top investment priority for NASA Space Astronomy this decade. It is a model of international cooperation and collaboration and it continues to thrive under a philosophy that demands clear, centralized management and strong systems engineering. As of today, the team has proven all major technologies, including the viability of lightweight active optics and image-based wavefront sensing and control. In partnership with Northrop Grumman as the prime contractor, the JWST project is continuing to achieve all milestones toward the transition to phase C development. In the end, JWST will touch and inspire the lives of thousands of scientists and engineers from across the United States, Canada and Europe, to say nothing of the astronomers worldwide, whose discoveries using JWST may well change the way we see ourselves and our place in the universe.

NORTHROP GRUMMAN JWST Prime
Space Technology Contractor



Optical System Development

ITT

Telescope Integration and Test



Telescope Structure

- Observatory performance and programmatic
- Systems engineering and interfaces
- Spacecraft, Sunshield, and deployables
- Observatory integration and test
- Support ground segment and operations
- Optical Telescope Element (OTE) optical design and optics
- Beryllium mirror segment development and cryogenic testing
- Wavefront Sensing & Control (WFS&C) design and algorithms
- OTE and Observatory AI&T support
- OTE ground AI&T
- Plum Brook test configuration and interfaces
- Telescope backplane and Secondary Mirror (SM) support structure design and build

ESA/European Consortium

CSA

University of Arizona

JPL

MSFC

AMES

- NIRSpec Instrument
- MIRI OBA (Optical Bench Assembly) and instrument integration & test
- Ariane 5 launch vehicle
- FGS with tunable filter modules
- NIRCам instrument (subcontracted to Lockheed-Martin ATK)
- MIRI management and systems engineering team lead, flight software, FPA/FPE and dewar
- Wave Front Sensing and Control (WFS&C) technology development and oversight
- Mirror technology development and testing
- Environmental analysis
- Detector technology development

International partnering is an important way for NASA to keep down costs for this order-of-magnitude increase in scientific capability over that of Hubble. The European Space Agency (ESA) is contributing about \$230 million Euro for a 15 percent observing share and the Canadian Space Agency (CSA) will contribute more than \$50 million for its roughly 5 percent share.

In addition to its partnerships with Europe and Canada, NASA has relied on the expertise of its field centers, including the Goddard Space Flight Center, Ames Research Center, the Jet Propulsion Laboratory and the Marshall Space Flight Center, and several of the Department of Energy's national laboratories. The Space Telescope Science Institute, the same organization that now operates Hubble, will operate JWST's Science and Operations Center. Universities and a variety of industry groups scattered across the country are also involved in one form or another with the JWST program.

The Department of Defense (DoD) contributed to the technology development effort. It helped to fund the joint advanced mirror technology-development (AMSD) program that led to the development of semi-rigid beryllium mirrors chosen for JWST.

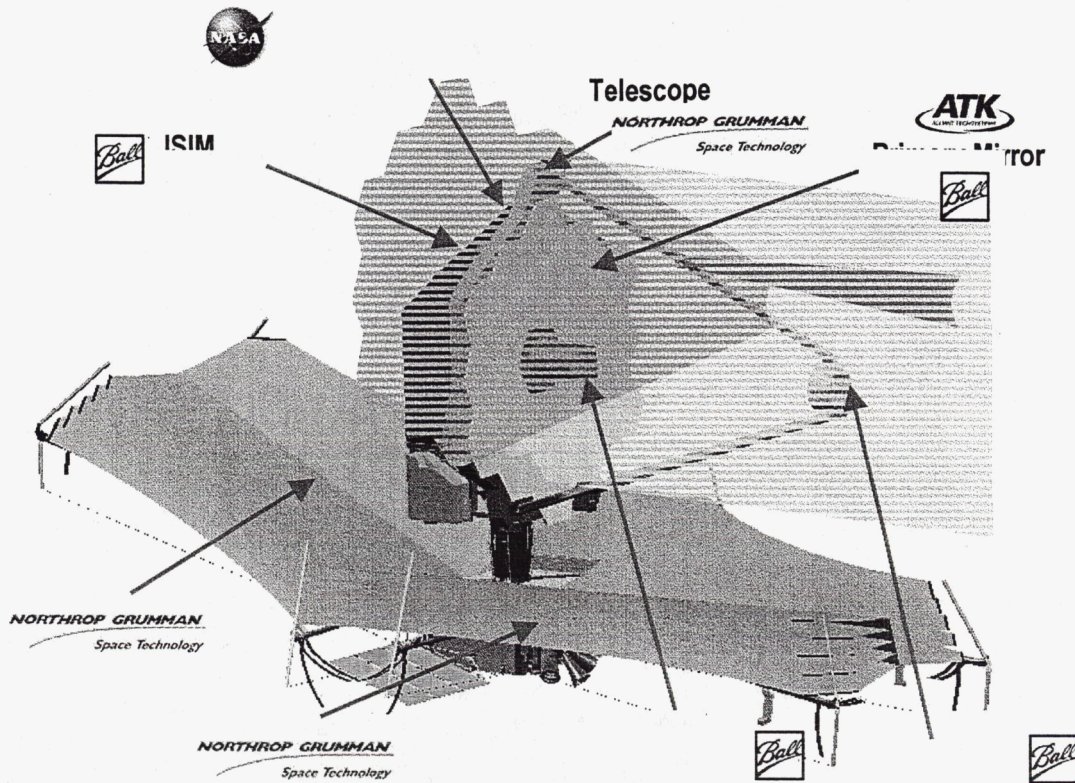

Figure 14. JWST Observatory Showing Responsibilities of Team Members

11. PARTNERSHIPS and TEAM MEMBERS

The table below shows the various JWST team members and their roles and responsibilities as also shown in Figure 14.

	<ul style="list-style-type: none"> - Overall project management - Overall systems engineering - Leadership of Science Working Group (SWG)
GSFC	<ul style="list-style-type: none"> - ISIM engineering, manufacturing and integration and test - Specific Engineering Directorate responsibilities; ISIM Command and Data Handling (IC&DH) with software, ISIM Structure, Micro Shutter Assembly (MSA) and electronics with software and NIRSpec detectors, detector electronics, software and harness
NGST	<ul style="list-style-type: none"> - Observatory systems engineering - Observatory (OTE, spacecraft and ISIM) integration and test - OTE, spacecraft bus and sunshield design, manufacturing, integration and test - Launch site processing, observatory launch and commissioning
STScI	<ul style="list-style-type: none"> - Ground systems development - Flight and science operations - Optics and instrument support

10. OBSERVATORY SPACECRAFT BUS

The spacecraft (Figure 13) provides the housekeeping function of the Observatory. It has a 471 Gigabits solid-state recorder that stores all science data as well as engineering data that is collected in between and during the daily contacts with the ground station. Two star trackers (an additional one for redundancy) are used to point the Observatory toward the science target prior to guide star acquisition, and they provide roll stability about the telescope line of sight (V1 axis.) Six reaction wheels (2 are redundant) are mounted on isolators near the center of gravity of the bus to reduce disturbances to the Observatory. These reaction wheels offload the fine steering control (operation from a 16 Hz update from the FGS) to maintain the fine steering mirror near its central position to limit differential distortion induced blurring onto the target star. Two fixed solar arrays canted toward the sun when the Observatory is pointed in the middle of its FOR provide power. The downlink operates at Ka band and has a selectable rate of 7, 14 or 28 Mbps. A pair of omni directional antennas (at S-band) provide near hemispherical coverage for emergency communications.

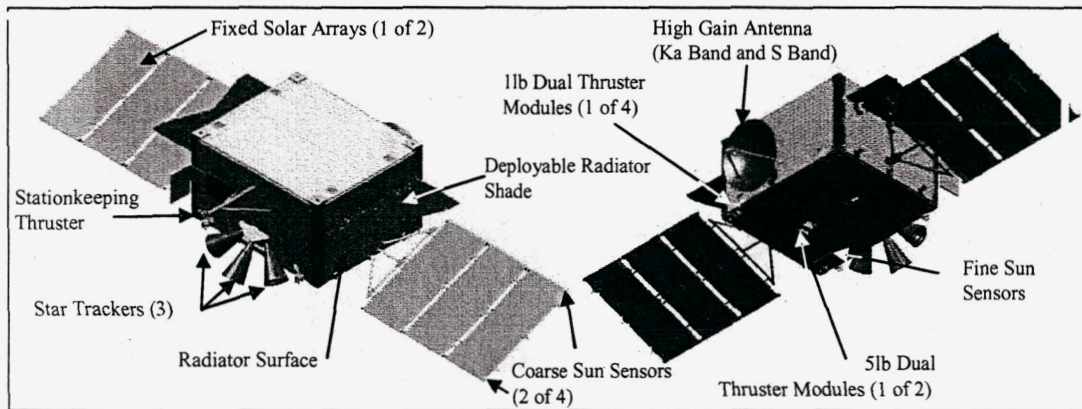

Figure 13. JWST Spacecraft Bus External Configuration

detectors exhibit maximum sensitivity at a temperature of ~7 K and will be cooled below the nominal 40 K ISIM temperature by a mechanical cryo-cooler.

9. MICROSHUTTERS

Multi-object spectroscopy using JWST's Near-Infrared Spectrometer represents another quantum leap in space-based astronomy. To characterize the nature of the early universe, JWST will have to take spectral data of many different targets simultaneously. The NIRSpec instrument utilizes a Micro-Shutter Array (MSA) for aperture control. The MSA, shown in Figures 10-12, is a rectangular array of microscopic (~100 x 300 microns) magnetically controlled, transmissive shutters, which can be latched open or closed under computer control, allowing the production of any required input slit pattern for use in a manner similar to a ground-base punch-plate spectrograph.

The enabling technology for this aperture control comes from a new area of engineering called Micro Electrical Mechanical Systems (MEMS) in which techniques originally developed for fabrication of integrated electronic circuits are applied to fabrication of microscopic machines. JWST conducted an extensive technology development program in which three teams from within NASA and Sandia National Laboratory competed to develop a flight qualified MEMS aperture control solution for JWST multi-object spectroscopy. Candidate designs involved both micro-mirrors and micro-shutters. The micro-shutter approach was selected for flight and is being developed by GSFC for delivery to the ESA NIRSpec team.

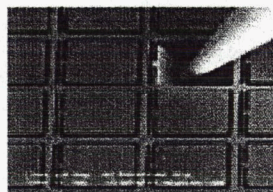
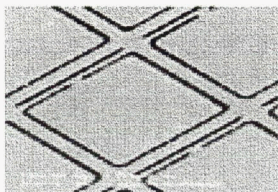

Figure 10. Electron micrograph of a prototype JWST micro-shutter array. Light shields that mask gaps around the periphery of each shutter are removed for clarity.

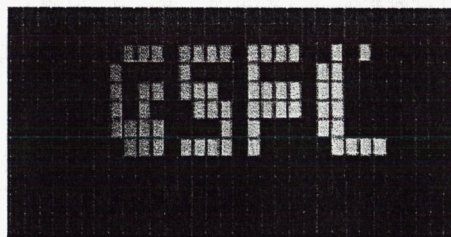

Figure 11. 64 X 128 MSA array electrically addressed to display 'GSFC'

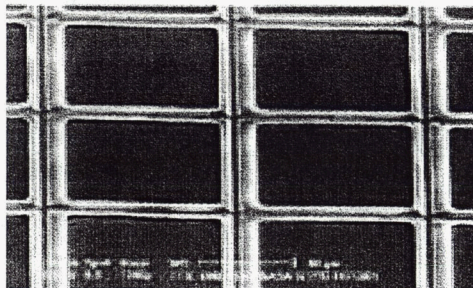

Figure 12. Close up of 100 X 200 micron pixel size with light shields attached

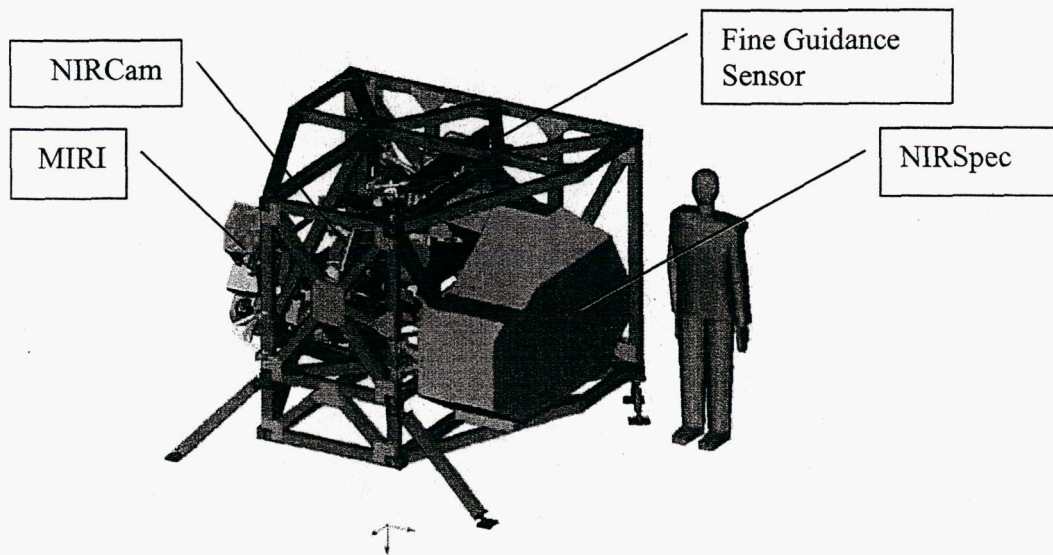

Figure 9. ISIM. (Enclosure removed for clarity)

8. DETECTORS

More than any other component, the detector determines the sensitivity of an instrument. Its role is to record the position, intensity and, by means of filters and spectrographs, the wavelength of as much of the incident radiation as possible. Because JWST's prime targets are intrinsically faint, with fluxes as low as a single photon arriving every second, its detectors must be more sensitive than any detector ever flown. Furthermore, because the detectable first star-forming regions in the universe are very rare, JWST must be able to image large areas of the sky, and JWST's detector assemblies must be large mosaic arrangements of up to 16 million pixels per focal plane array (FPA).

JWST's near-infrared instruments have selected Rockwell HAWAII-2RG (H2RG) mercury-cadmium-telluride (HgCdTe) detectors. These detectors, which represent the state-of-the-art in this wavelength regime, are the fruit of a highly successful JWST's Phase-A technology development program. Under this program, Rockwell Scientific and Raytheon Vision Systems developed 2048 x 2048 sensor chip assemblies (SCAs) and prototype 16 Mpixel FPAs. JWST candidate SCAs were tested at purpose built vendor affiliated labs at the University of Hawaii and University of Rochester respectively, and independently at the Space Telescope Science Institute. Upon completion of the technology development program, NIRCam selected Rockwell H2RG detectors and the other near-infrared instruments, including the NIRSpec and Fine Guidance Sensors, selected H2RG detectors shortly thereafter.

The near-infrared detectors will be controlled by adjacent, cryogenic, application-specific integrated circuits (ASICs) also developed by Rockwell Scientific. These cryo-ASICs will provide clock and bias signals to the detectors and perform analog-to-digital conversion of the detector outputs. The cryo-ASICs enable transmission of JWST's science data along a purely digital link from the observatory's cryogenic region to the instruments' warm electronics four meters away.

Following Spitzer Space Telescope heritage, the mid-infrared instrument, MIRI, has selected arsenic-doped silicon (Si:As) detectors developed by Raytheon Vision Systems. JWST also conducted a pre-phase A development program for this technology to grow the Spitzer era 256 x 256 pixel format to 1024 x 1024. These