

NASA/CR—2005-214018



# Development of a Stirling System Dynamic Model With Enhanced Thermodynamics

Timothy F. Regan and Edward J. Lewandowski  
Sest, Inc., Middleburg Heights, Ohio

---

November 2005

## The NASA STI Program Office . . . in Profile

Since its founding, NASA has been dedicated to the advancement of aeronautics and space science. The NASA Scientific and Technical Information (STI) Program Office plays a key part in helping NASA maintain this important role.

The NASA STI Program Office is operated by Langley Research Center, the Lead Center for NASA's scientific and technical information. The NASA STI Program Office provides access to the NASA STI Database, the largest collection of aeronautical and space science STI in the world. The Program Office is also NASA's institutional mechanism for disseminating the results of its research and development activities. These results are published by NASA in the NASA STI Report Series, which includes the following report types:

- **TECHNICAL PUBLICATION.** Reports of completed research or a major significant phase of research that present the results of NASA programs and include extensive data or theoretical analysis. Includes compilations of significant scientific and technical data and information deemed to be of continuing reference value. NASA's counterpart of peer-reviewed formal professional papers but has less stringent limitations on manuscript length and extent of graphic presentations.
- **TECHNICAL MEMORANDUM.** Scientific and technical findings that are preliminary or of specialized interest, e.g., quick release reports, working papers, and bibliographies that contain minimal annotation. Does not contain extensive analysis.
- **CONTRACTOR REPORT.** Scientific and technical findings by NASA-sponsored contractors and grantees.

- **CONFERENCE PUBLICATION.** Collected papers from scientific and technical conferences, symposia, seminars, or other meetings sponsored or cosponsored by NASA.
- **SPECIAL PUBLICATION.** Scientific, technical, or historical information from NASA programs, projects, and missions, often concerned with subjects having substantial public interest.
- **TECHNICAL TRANSLATION.** English-language translations of foreign scientific and technical material pertinent to NASA's mission.

Specialized services that complement the STI Program Office's diverse offerings include creating custom thesauri, building customized databases, organizing and publishing research results . . . even providing videos.

For more information about the NASA STI Program Office, see the following:

- Access the NASA STI Program Home Page at <http://www.sti.nasa.gov>
- E-mail your question via the Internet to [help@sti.nasa.gov](mailto:help@sti.nasa.gov)
- Fax your question to the NASA Access Help Desk at 301-621-0134
- Telephone the NASA Access Help Desk at 301-621-0390
- Write to:  
NASA Access Help Desk  
NASA Center for AeroSpace Information  
7121 Standard Drive  
Hanover, MD 21076

NASA/CR—2005-214018



# Development of a Stirling System Dynamic Model With Enhanced Thermodynamics

Timothy F. Regan and Edward J. Lewandowski  
Sest, Inc., Middleburg Heights, Ohio

Prepared for the  
Space Technology and Applications International Forum (STAIF-2005)  
sponsored by the University of New Mexico's Institute for Space  
and Nuclear Power Studies (UNM-ISONPS)  
Albuquerque, New Mexico, February 13-17, 2005

Prepared under Contract NAS3-03064

National Aeronautics and  
Space Administration

Glenn Research Center

---

November 2005

## Acknowledgments

This work was performed for NASA Headquarters, Office of Space Science (Code S) under the Prometheus Program and was supported by the NASA Glenn Research Center Contract NAS3-03064. The authors gratefully acknowledge the input and suggestions of Barry Penswick (consultant) and Jeff Schreiber, NASA Glenn Research Center, in this work.

Trade names or manufacturers' names are used in this report for identification only. This usage does not constitute an official endorsement, either expressed or implied, by the National Aeronautics and Space Administration.

Available from

NASA Center for Aerospace Information  
7121 Standard Drive  
Hanover, MD 21076

National Technical Information Service  
5285 Port Royal Road  
Springfield, VA 22100

Available electronically at <http://gltrs.grc.nasa.gov>

# Development of a Stirling System Dynamic Model With Enhanced Thermodynamics

Timothy F. Regan and Edward J. Lewandowski  
Sest, Inc.  
Middleburg Heights, Ohio 44130

## Abstract

The Stirling Converter System Dynamic Model developed at NASA Glenn Research Center is a software model developed from first principles that includes the mechanical and mounting dynamics, the thermodynamics, the linear alternator, and the controller of a free-piston Stirling power convertor, along with the end user load. As such it represents the first detailed modeling tool for fully integrated Stirling convertor-based power systems. The thermodynamics of the model were originally a form of the isothermal Stirling cycle. In some situations it may be desirable to improve the accuracy of the Stirling cycle portion of the model. An option under consideration is to enhance the SDM thermodynamics by coupling the model with Gedeon Associates' Sage simulation code. The result will be a model that gives a more accurate prediction of the performance and dynamics of the free-piston Stirling convertor. A method of integrating the Sage simulation code with the System Dynamic Model is described. Results of SDM and Sage simulation are compared to test data. Model parameter estimation and model validation are discussed.

## Introduction

In recent years there has been significant development of free-piston Stirling convertors for potential use on NASA exploration missions (Schreiber and Thieme, 2004). In support of this development effort, a detailed nonlinear system-level dynamic model has been created, referred to as the Glenn Research Center (GRC) Stirling Converter System Dynamic Model (SDM) (Lewandowski and Regan, 2004). While other Stirling models exist, none have the breadth and capability of the SDM. Governing equations of the model have been published previously, and therefore are not included in this paper. Figure 1 illustrates the fact that the SDM includes not only the Stirling Converter Assembly (SCA) but it also includes many of the other key parts of the power system. The SDM models the Stirling cycle thermodynamics, heat flow, working fluid, mechanical mass-spring damper systems and the linear alternator. It also includes the entire system from the thermal energy input to thermal rejection, mounting dynamics, the controller and electrical load including the power distribution system. This allows one to study the interactions among the various subsystems comprising a Stirling convertor-based power system. Thermal, mechanical, fluid, magnetic, and electrical aspects can be studied in one model. The SDM is a non-linear time-domain model

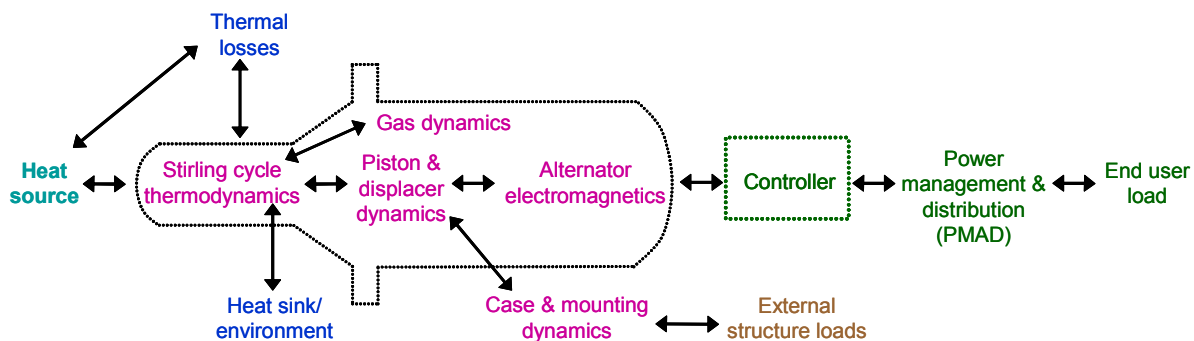

Figure 1.—SDM Model Structure.

containing sub-cycle dynamics, which simulates transient and dynamic phenomena that other models cannot. The entire range of convertor operation is modeled, from start-up to full power conditions.

The SDM has been developed as a “bottom-up” model based on first principles. Components are separately modeled, then combined into subsystems and ultimately into the system. Very few calibration factors have been used to correlate SDM simulation results with test data. The SDM can be set up to include multiple convertors in various mechanical and electrical configurations, including dual-opposed, parallel electrical, and series electrical configurations. It is being used to model free-piston convertors from less than 100 W to over 10 kW.

### System Dynamic Model (SDM)

SDM is a collection of inter-dependent circuit models of the various physical systems at work in a free-piston Stirling convertor. Circuit solutions obey conservation laws by their very nature. Circuit theory is a convenient framework for analysis in the electrical and mechanical domains because the through-quantities and across-quantities remain confined to the machine elements modeled in the circuit model. The electrical currents in SDM’s electrical circuits remain confined to the conductors. In SDM’s mechanical circuits, the velocity and position are confined to their associated rigid moving masses in the axial direction. Modeling the free-piston Stirling convertor in the thermal domain and the fluid domain offer more challenges because the flow paths for thermal and fluid

behavior are more than one-dimensional. Indeed the working fluid encounters changing direction, changing temperatures and changing cross-sectional areas as it flows through the convertor in the cycle. Similarly, the flow of heat through the gas spaces and the various metal boundaries of the convertor encounters more degrees of freedom than a one-dimensional circuit can accommodate. Nevertheless, by breaking the thermal and fluid flow paths up into segments with near-uniform characteristics, an adequate model can be made.

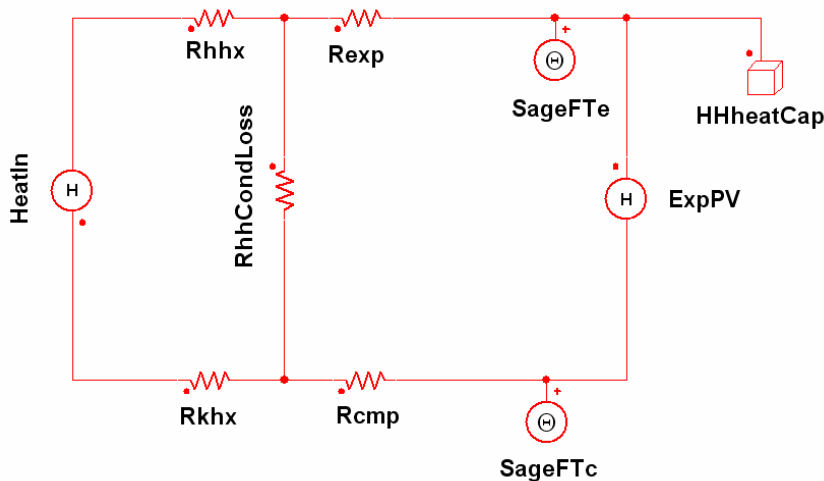

Figure 2.—SDM Thermal Circuit with Sage inputs.

In SDM, heat is modeled as flowing through the convertor’s structure from a source at the hot end to a rejection temperature sink connected to the cold end. The amount of heat flowing into the Stirling thermodynamic cycle is lumped into another heat source *ExpPV* connected to the heat sink, as shown in Fig. 2. The magnitude of the heat source is set equal to the expansion space PV power. The expansion space PV power is calculated from

$$PVpower = \oint Pdv , \tag{1}$$

where *P* is the instantaneous pressure and *v* is the instantaneous volume of the expansion space. SDM reports a new value for *ExpPV* once per cycle. The temperature of the hot end results from the circuit solution of the thermal circuit. It is the temperature that is directly related to pressure through the ideal gas law. As an example of circuit operation, consider the case in which the input heat to a model operating at steady state is increased, the circuit solution for temperature yields a higher value. The pressure rises due to the ideal gas law. The PV power increases as a result. The increased PV power enters the thermal circuit of Fig. 2 through the heat source *ExpPV* and has the effect of reducing the rise in temperature until eventually, it reaches a new steady state solution. SDM assumes that the expansion space temperature can be determined solely from the input heat and the calculated PV power. This is

the major simplifying assumption of SDM. By this assumption, SDM assumes the thermal resistances  $R_{hhx}$ ,  $R_{exp}$ ,  $R_{khx}$ , and  $R_{cmp}$  are equal to zero, neglecting temperature drops due to heat exchanger losses and losses to ambient through convection and radiation. Thus, SDM can dispense with all concern about heat exchanger performance, thickness of bounding surfaces and their materials of construction. Such a model suffers some inaccuracies as a result of the simplification and, of course, is of no use in gauging the effect of heat exchanger performance or materials of construction on dynamic performance.

The flow of working fluid is not modeled as a circuit in SDM. A circuit model cannot adequately model the fluid flow in the convertor because the fluid velocity varies along that path due to temperature change. A circuit requires a uniform through-quantity in a series connection. SDM uses equations rather than a circuit solution to calculate flow. The equations consider temperature, pressure, volume and the rates of change of pressure and volume in calculating flow. The flow is important because it is used to calculate the viscous damping and consequent amplitude of the displacer. The fact that the working fluid flows through viscous elements implies that there is a pressure drop across the elements. The pressure used in the flow calculation is assumed uniform throughout all the working spaces. This is the second simplifying assumption of SDM.

Comparison with test data shown in the graphs of Fig. 3 indicates the effect of the simplifying assumptions on the accuracy of the SDM.

### SDM Model Parameter Determination

SDM does not require the user to make assumptions about values for the piston amplitude or operating frequency. These variables are determined based on the dynamics during the simulation. As a result, it is critical to the SDM to have accurate models for components such as the flexures, gas springs, moving masses, and the alternator.

Flexures, if used, need to be modeled as nonlinear springs, since the nonlinear characteristics affect the dynamics and stability, especially at high piston and displacer amplitudes. The spring rate can be determined from static measurements. Testing has shown that for systems using multiple flexures, linear superposition of individual flexure spring rates can be used to determine the total effective spring rate. A 3<sup>rd</sup>-order curve fit of the test data of the form  $F = K_1 X^3 + K_2 X$  is generally sufficient to model the spring rate. There is no  $X^2$  term, assuming the spring is symmetric about the null position. The spring rate is then  $K = K_1 X^2 + K_2$ .

Flexure spring rate can also be determined using finite element analysis (FEA) methods. However, unless the inner diameter and outer diameter clamping is accurately modeled, the spring rate can be in error by several percent.

The effective masses for the piston and displacer can be determined by weighing the moving components. For flexures, the effective mass is approximately one third of the total mass when the inner diameter moves, and two thirds of the total mass when the outer diameter moves. It is recommended to use FEA to more accurately estimate the portion of the flexure mass to assign to the moving mass, especially when the flexure mass is significant.

Statically determined mass and spring rates can be corroborated with dynamic data. Natural frequency measurements can be made at low and high amplitudes to verify model parameters. A measurement of oscillatory decay can provide an estimate of a portion of piston or displacer damping.

The alternator magnet spring rate can be determined in a similar fashion to the method used for flexures. A 3<sup>rd</sup>-order equation of the form used to model the flexures can be used. Depending on the maximum amplitude of the alternator, though, end effects may need to be incorporated into the model.

The alternator model includes a resistance, an inductance, and alternator constants relating current to force and velocity to voltage. The resistance measurement is straightforward, and can be readily adjusted for temperature effects through a linear correction factor. The inductance measurement is made at the operating frequency. The alternator constants can be derived from alternator performance data at various amplitudes, loads, and temperatures. In this way effects like the temperature effect on the magnets' remanent flux density  $B_r$  can be incorporated. The open loop voltage provides a good estimate of the alternator's internal voltage, or EMF. If the alternator travel is not limited to the linear region, end effects at high amplitudes need to be incorporated. This is especially important when using the SDM to perform stability analysis.

SDM model parameters have been determined using the methods described above for the 55-We Technology Demonstration Converter (TDC) Stirling convertor at GRC. The TDC is designed and manufactured by Stirling Technology Company (STC) of Kennewick, WA. By accurately modeling dynamic characteristics associated with flexures, gas springs, magnets, masses, capacitors, thermal inertias and other components, including their nonlinearities, the SDM shows good correlation with test data even with the simplified Stirling cycle model assumptions. For example, the operating frequency is within 1 Hz of the actual operating frequency. The transient response and dynamic characteristics of the SDM have been reported in Regan and Lewandowski (2004).

### SDM Performance With Simplifying Assumptions

When comparing the performance of a Stirling model to test data, a number of performance metrics can be examined. During steady-state simulation, variables like output power, displacer phase angle, pressure phase angle, pressure amplitude, piston amplitude, displacer amplitude, operating frequency, output current, output voltage, and various thermal, pressure, and power losses can be compared. However, as in the case of any evaluation process, great care must be exercised to insure that the potential errors in the test data are well understood. This is particularly true for free-piston systems due to the close interactions between the various components and the limited number of measured parameters available. This can lead to situations where portions of the measured data may be internally

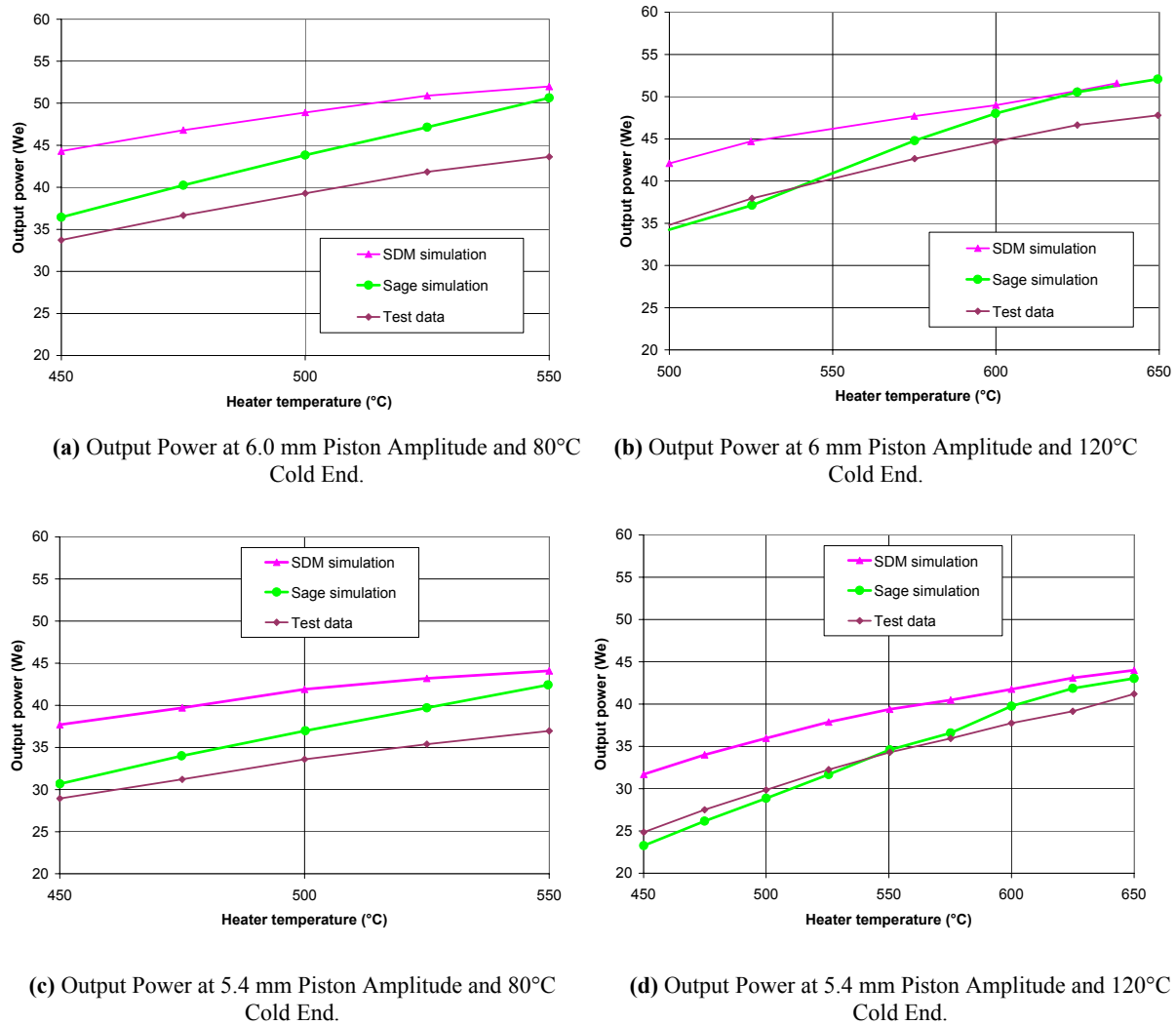

Figure 3.—SDM Model vs. Sage Model vs. Test Data.



inconsistent. In addition, a number of the key components can have operating characteristics which vary significantly with relatively small changes in operating parameters, for example the linear alternator efficiency. This can lead to significant errors when attempting to extract internal component characteristics from external measurements.

The SDM steady-state performance was validated by comparing model output with test data taken on the TDC at GRC. Figure 3 shows the SDM prediction of convertor output power vs. test data. Over the range of operating temperatures and piston amplitudes modeled, the output power predicted by SDM is between 6 and 31% high, with an average error of 20%. This error is attributed to SDM's use of the simplifying assumptions described above. The thermal circuit of Fig. 2 yields a higher-than-actual working space temperature in the expansion space and a lower-than-actual temperature in the compression space.

Other variables were compared to test data. For the TDC convertor at the test conditions studied, the displacer phase angle predicted by SDM is 6° to 10° lower than actual. The pressure angle is about 5° to 15° higher than actual. The amplitude of the pressure wave is 5 to 25 kPa lower than actual. The differences in phase angles are attributed to the simplified treatment of fluid flow. This difference is explained in the section on Sage/SDM integration.

Alternative models have been developed for the Stirling cycle besides the modified Schmidt's analysis currently used by SDM. An adiabatic model, developed by Benvenuto and DeMonte (1992), generally gives a more accurate performance prediction than Schmidt's analysis. A version of SDM is being developed for evaluation based on the adiabatic model.

### Sage Model

Sage is a dedicated thermodynamic code for modeling Stirling-cycle based machines, developed by Gedeon Associates of Athens, OH (Gedeon, 1995). For the TDC, SDM models a Stirling convertor having coaxial piston and displacer and annular heat exchangers connecting the expansion space with the compression space. The corresponding Sage model is shown in Fig. 4. It comprises cylinders for the expansion and compression spaces. The construction materials and geometry of these cylinders as well as those of the heat exchangers and regenerator have been chosen to correspond with those of the TDC. The heat transfer properties are calculated by Sage for any operating temperature, pressure, frequency and piston motion entered into the Sage program as parameters.

The power piston is modeled as what Sage refers to as a "phasor-constrained reciprocator." The fact that it is phasor-constrained means that it is limited to sinusoidal motion with amplitude keyed into the graphical user interface by the user. The displacer is also kept to sinusoidal motion, but Sage will calculate its amplitude and phase

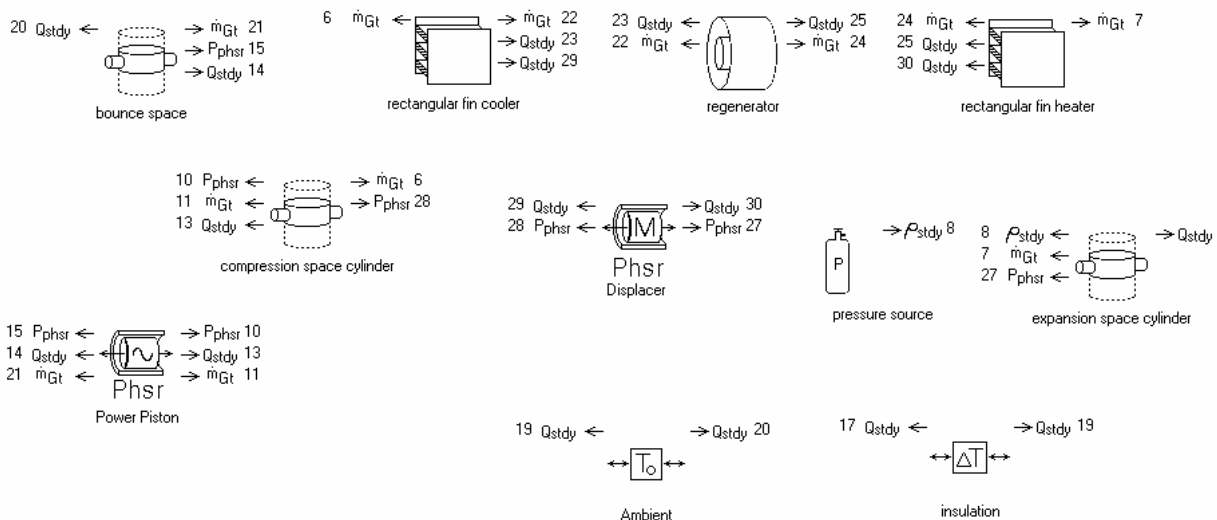

Figure 4.—Sage Model Linked to SDM.

angle. Sage refers to such a construct as a “free reciprocator.” Its amplitude and phase angle relative to the piston’s motion are determined by the pressure forces acting on it and the spring force exerted by a spring connecting the displacer to the case. The displacer has child components including a cylinder and a flexure spring. The piston’s child components include a cylinder, a seal and an appendix gap. The Sage model is configured to calculate mechanical power, heat transfer, seal leakage losses, and flow losses for the specified operating condition. Unlike SDM, the Sage model simulation considers the heat transfer characteristics of the gas boundaries as specified by the user and calculates the temperature variation in the working spaces over the cycle.

Sage output power was calculated by the model of Fig. 4 for the same conditions for which SDM and test results are plotted in Fig. 3. The Sage results are consistently closer to the true (test) values than SDM’s results. This indicates that incorporation the more sophisticated treatment of losses and working space temperatures in Sage results in a more accurate model. Fig 3 shows that in some of the simulations, the Sage calculations are very close to the test data. In other cases, especially at high values of temperature difference, the Sage results depart significantly from test data. Sage inaccuracies can be reduced through a more accurate determination of heat transfer and pressure drop coefficients (Qiu and Augenblick, 2004). When Sage’s temperatures, operating frequency and piston amplitude are valid, the resulting input and output powers are accurate. The SDM Sage interface will be able to supply Sage with these input parameters. Sage, in its turn, provides SDM with the time-varying temperatures in the expansion and compression spaces. These temperatures were calculated using Sage’s detailed modeling of the heat transfer at the gas boundaries. They are used to free SDM from its simplifying assumptions and allow more realistic model performance.

## Integrating Sage With the SDM

It has been mentioned above that SDM lacks the ability to calculate the actual time-varying temperatures of the working spaces because it does not process any heat transfer characteristics at the gas boundaries in the convertor. It was also observed that Sage generally uses piston amplitude, operating frequency and mean working space pressure as inputs of the Sage model. A method of integrating SDM and Sage has been developed which uses the outputs of each model to supply what the other model lacks. Applying this method, the piston amplitude, operating frequency, mean working space pressure, and mean heater and cooler temperatures are passed to Sage from SDM. Sage results are then made available at the interface for use in SDM. In the specific method used as a test of the technique, the cyclic temperature variations in the expansion space and compression space are calculated by Sage and passed back to SDM. The temperature used by SDM to calculate its pressure wave is the sum of the mean temperature and the time-varying temperature. The thermal circuit model shown in Fig. 2 contains not only the means to solve for the mean expansion space temperature, already discussed, but it also has a temperature source for adding in the time-varying component of the expansion space temperature. This source is labeled *SageF<sub>T</sub>e*. Its output temperature is the sum of the mean temperature and the time-varying part that is obtained from Sage. The

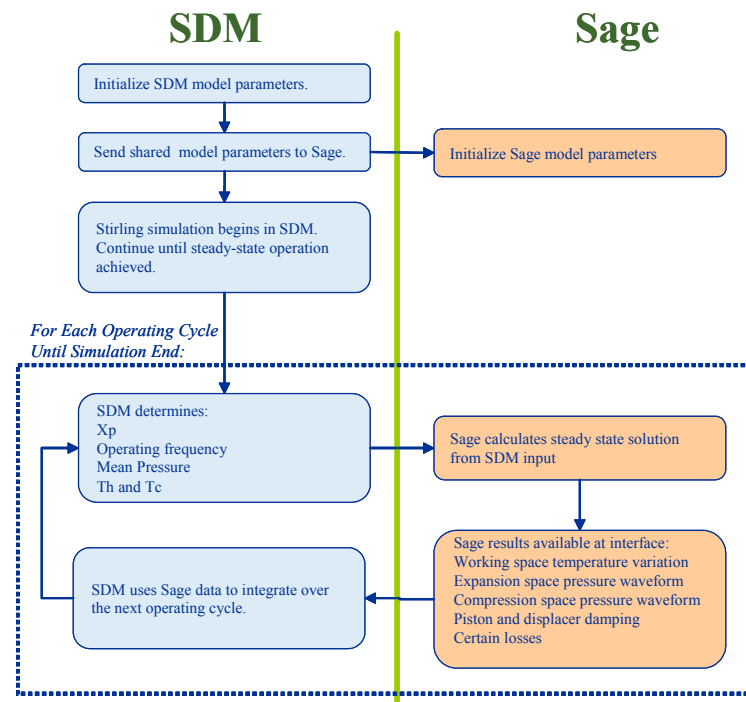

Figure 5.—Schematic of Sage Integration with SDM.

time-varying compression space temperature is handled in a similar fashion by the source labeled *SageFTc* in Fig. 2. A key element in the proposed approach will be insuring that the two simulations do not enter into an “infinite loop” situation in which true steady state conditions are never reached.

## Software Integration

Gedeon Associates has provided an add-on to Sage to enable operation of the software outside of Sage’s normal graphical user interface. The add-on is called the Sage Stirling DLL. It is a Windows Dynamic Linked Library (DLL) which provides a number of functions callable from C or C++. The member functions contained in the DLL provide the ability to open and close a Sage model, to supply Sage with an input value and to get an output value from Sage. Sage will only supply outputs from solved models, so that if the model has not yet been solved when the function *GetReal()* for getting an output is called, it first solves the model and then sends the value to the function. SDM uses the Ansoft Simplorer platform which provides a C++ utility allowing development of custom elements coded from a convenient C++ template. A library of Sage interface modules developed using the C/C++ facility of Simplorer is envisioned. One element will be used to initialize the Sage model so that Sage and SDM are always considering the same model. Other elements will be used to pass the various values back and forth between Sage and SDM.

More than one interface scheme is certainly possible and it is likely that some will perform better than others. The one that has been mentioned above – i.e., the working space dynamic temperature method – represents one of these approaches. The Sage interface calculates new values for the amplitude and phase angles of the time-varying portion of the expansion space and compression space temperatures based on SDM values for mean working space pressure, piston amplitude, mean temperatures of the expansion and compression space and operating frequency. The two models describe the same geometry and contain the same losses. The Sage model is a constrained-piston free-displacer type model. The temperatures calculated will correspond to a valid steady state operating point of the Sage model. The method does not depend upon making the solutions of the two models agree before proceeding with the simulation. Rather, Sage is treated as a subroutine of SDM that calculates the time-variation of the working space temperatures. Once SDM has obtained the temperature information, it proceeds with its simulation.

The difference between SDM running in this mode and previous modes is that now the more sophisticated Stirling working space temperatures are used. They include the realistic effects of heat transfer to the gas boundaries without the need to calculate it in SDM.

Other options include techniques such as a pressure factor-based approach, where piston and displacer are driven by a factored pressure wave. In this approach, the SDM would utilize pressure factors calculated by Sage to determine piston and displacer pressure forces. This approach and others will be investigated in the future as time and technical merit permit.

## Conclusions

The GRC Stirling convertor SDM has been developed to evaluate the characteristics of fully integrated Stirling convertor based power systems. In some situations it has also been employed to model actual Stirling convertor test results over a wide range of operating conditions with varying levels of accuracy. The differences seen between SDM and test data are expected, due to a number of the fundamental assumptions employed. In an effort to improve SDM accuracy for these specific situations, a number of options are being investigated. The method discussed in this paper inserted working space temperatures calculated by Sage into the pressure wave calculation of SDM. The test cases run to date show significant improvement in fidelity of the model. The displacer phase angle, which had been low by 6° to 10° before the insertion of the Sage temperatures, was brought to no further than 1.5° from the Sage results after the insertion. The output power and pressure wave amplitude were brought closer to the Sage results as well.

The integration of Sage working space temperatures into SDM represents one option which provided improved model accuracy. Other methods are under consideration and they may provide even greater improvements to SDM’s thermodynamic modeling.

## Nomenclature

<i>Br</i>	remanent flux density (T)	<i>Rhhx</i>	heater thermal resistance (K/W)
<i>ExpPV</i>	expansion space PV power (W)	<i>Rkxx</i>	cooler thermal resistance (K/W)
<i>F</i>	force (N)	<i>RhhcondLoss</i>	heater head conduction loss (K/W)
<i>HeatIn</i>	Heat input (W)	<i>SageFTe</i>	expansion space temperature (K)
<i>HHheatCap</i>	heater head thermal capacitance (W*s/K)	<i>SageFTc</i>	compression space temperature (K)
<i>K</i>	spring rate (N/m)	<i>Tc</i>	cooler temperature (K)
<i>K<sub>1</sub>, K<sub>2</sub></i>	spring rate coefficients	<i>Th</i>	heater temperature (K)
<i>m<sub>Gi</sub></i>	mass flow rate (kg/s)	<i>T<sub>o</sub></i>	ambient temperature (K)
<i>P</i>	pressure (Pa)	<i>V</i>	volume (m <sup>3</sup> )
<i>P<sub>phsr</sub></i>	pressure phasor (Pa)	<i>Wnet</i>	displacer net work (W)
<i>Q<sub>stdy</sub></i>	steady state heat flow (W)	<i>Xd</i>	displacer position (m)
<i>Rcmp</i>	thermal resistance into compression space (K/W)	<i>Xp</i>	piston position (m)
<i>Rexp</i>	thermal resistance into expansion space (K/W)	<i>ΔT</i>	temperature drop (K)

## References

- Benvenuto, G. and DeMonte, F., "An Adiabatic Approach for the Design and the Response-to-Load Evaluation of Free-Piston Stirling Engines," 1992, SAE Paper No. 929066.
- Gedeon, D., "Sage: Object-Oriented Software for Cryocooler Design," *Cryocoolers 8*, Edited by R.G. Ross, Jr., Plenum Press, New York, 1995, pp. 281-292.
- Lewandowski, E.J. and Regan, T.F., "Overview of the GRC Stirling Convertor System Dynamic Model," in proceedings of the *Second International Energy Conversion Engineering Conference (IECEC 2004)*, American Institute for Aeronautics and Astronautics, 2004. AIAA-2004-5671.
- Qiu, S. and Augenblick, J.E., "Conceptual Design Update for an Improved Stirling Convertor," in proceedings of the *Second International Energy Conversion Engineering Conference (IECEC 2004)*, American Institute for Aeronautics and Astronautics, 2004. AIAA-2004-5623.
- Regan, T.F., Lewandowski, E.J., "Application of the GRC Stirling Convertor System Dynamic Model," in proceedings of the *Second International Energy Conversion Engineering Conference (IECEC 2004)*, American Institute for Aeronautics and Astronautics, 2004. AIAA-2004-5672.
- Schreiber, J.G, and Thieme, L.G., "Accomplishments of the NASA GRC Stirling Technology Development Project," in Proceedings of the *Second International Energy Conversion Engineering Conference (IECEC 2004)*, American Institute for Aeronautics and Astronautics, 2004. AIAA-2004-5517.

# REPORT DOCUMENTATION PAGE

*Form Approved*  
*OMB No. 0704-0188*

Public reporting burden for this collection of information is estimated to average 1 hour per response, including the time for reviewing instructions, searching existing data sources, gathering and maintaining the data needed, and completing and reviewing the collection of information. Send comments regarding this burden estimate or any other aspect of this collection of information, including suggestions for reducing this burden, to Washington Headquarters Services, Directorate for Information Operations and Reports, 1215 Jefferson Davis Highway, Suite 1204, Arlington, VA 22202-4302, and to the Office of Management and Budget, Paperwork Reduction Project (0704-0188), Washington, DC 20503.

<b>1. AGENCY USE ONLY</b> <i>(Leave blank)</i>	<b>2. REPORT DATE</b> November 2005	<b>3. REPORT TYPE AND DATES COVERED</b> Final Contractor Report	
<b>4. TITLE AND SUBTITLE</b>  Development of a Stirling System Dynamic Model With Enhanced Thermodynamics		<b>5. FUNDING NUMBERS</b>  WBS-22-972-20-01 NAS3-03064	
<b>6. AUTHOR(S)</b>  Timothy F. Regan and Edward J. Lewandowski		<b>8. PERFORMING ORGANIZATION REPORT NUMBER</b>  E-15333	
<b>7. PERFORMING ORGANIZATION NAME(S) AND ADDRESS(ES)</b>  Sest, Inc. 18000 Jefferson Park Road Suite 104 Middleburg Heights, Ohio 44130		<b>10. SPONSORING/MONITORING AGENCY REPORT NUMBER</b>  NASA CR-2005-214018	
<b>9. SPONSORING/MONITORING AGENCY NAME(S) AND ADDRESS(ES)</b>  National Aeronautics and Space Administration Washington, DC 20546-0001		<b>11. SUPPLEMENTARY NOTES</b>  Prepared for the Space Technology and Applications International Forum (STAIF-2005) sponsored by the University of New Mexico's Institute for Space and Nuclear Power Studies (UNM-ISNPS), Albuquerque, New Mexico, February 13-17, 2005. Project Manager, Jeffrey G. Schreiber, Power and Electric Propulsion Division, NASA Glenn Research Center, organization code RPT, 216-433-6014.	
<b>12a. DISTRIBUTION/AVAILABILITY STATEMENT</b>  Unclassified - Unlimited Subject Categories: 20 and 44  Available electronically at <a href="http://gltrs.grc.nasa.gov">http://gltrs.grc.nasa.gov</a>  This publication is available from the NASA Center for AeroSpace Information, 301-621-0390.		<b>12b. DISTRIBUTION CODE</b>	
<b>13. ABSTRACT</b> <i>(Maximum 200 words)</i>  The Stirling Convertor System Dynamic Model developed at NASA Glenn Research Center is a software model developed from first principles that includes the mechanical and mounting dynamics, the thermodynamics, the linear alternator, and the controller of a free-piston Stirling power convertor, along with the end user load. As such it represents the first detailed modeling tool for fully integrated Stirling convertor-based power systems. The thermodynamics of the model were originally a form of the isothermal Stirling cycle. In some situations it may be desirable to improve the accuracy of the Stirling cycle portion of the model. An option under consideration is to enhance the SDM thermodynamics by coupling the model with Gedeon Associates' Sage simulation code. The result will be a model that gives a more accurate prediction of the performance and dynamics of the free-piston Stirling convertor. A method of integrating the Sage simulation code with the System Dynamic Model is described. Results of SDM and Sage simulation are compared to test data. Model parameter estimation and model validation are discussed.			
<b>14. SUBJECT TERMS</b>  Stirling engines; Design analysis; Block diagrams; Electromechanics; Dynamic models; Simulation; AC generators; Linear alternators; Stirling cycle		<b>15. NUMBER OF PAGES</b> 14	
<b>17. SECURITY CLASSIFICATION OF REPORT</b> Unclassified		<b>16. PRICE CODE</b>	
<b>18. SECURITY CLASSIFICATION OF THIS PAGE</b> Unclassified	<b>19. SECURITY CLASSIFICATION OF ABSTRACT</b> Unclassified	<b>20. LIMITATION OF ABSTRACT</b>	



