

# Precision Linear Actuators for the Spherical Primary Optical Telescope Demonstration Mirror

Jason Budinoff\* and David Pfenning\*

## Abstract

The Spherical Primary Optical Telescope (SPOT) is an ongoing research effort at Goddard Space Flight Center developing wavefront sensing and control architectures for future space telescopes. The Ø3.5-m SPOT telescope primary mirror is comprised of six 0.86-m hexagonal mirror segments arranged in a single ring, with the central segment missing<sup>2</sup>. The mirror segments are designed for laboratory use and are not lightweighted to reduce cost. Each primary mirror segment is actuated and has tip, tilt, and piston rigid-body motions. Additionally, the radius of curvature of each mirror segment may be varied mechanically. To provide these degrees of freedom, the SPOT mirror segment assembly requires linear actuators capable of <10-nm resolution over a total stroke of 5 mm. These actuators must withstand high static loads as they must support the mirror segment, which has a mass of ~100 kg. A stepper motor driving a differential satellite roller screw was designed to meet these demanding requirements. Initial testing showed that the actuator is capable of sub-micron repeatability over the entire 6-mm range, and was limited by 100-200 nm measurement noise levels present in the facility. Further testing must be accomplished in an isolated facility with a measurement noise floor of <5 nm. Such a facility should be ready for use at GSFC in the early summer of 2006, and will be used to better characterize this actuator.

## Introduction

Future large (>6 m) space telescopes such as the James Webb Space Telescope, SAFIR, and beyond require segmented primary mirrors to package into launch vehicle payload fairings of diameters less than their apertures. Requisite architectures to align or “phase” the individual segments into a single optical surface after launch and deployment are required. Current techniques used on large ground-based telescopes such as Keck include precision segment edge sensors<sup>4</sup> and various types of wavefront sensors<sup>5</sup>. However, phasing a large number of segments requires a significant amount of computing resources which can reduce observing efficiency. Maintaining a “phased” array of mirror segments in a challenging environment such as low-earth or L2 orbits remains to be seen. The SPOT research testbed will explore a new method of phasing segmented mirrors. The SPOT telescope architecture has possible application to a robotically assembled telescope for ISS, as shown in Figure 1.



**Figure 1. A possible application of the SPOT telescope architecture: a telescope mounted on the “top” (zenith) end of the Z1 truss**

### Wavefront Sensing and Control

A relatively recent technique utilizing image-based wavefront sensing has been pursued by the GSFC optics branch, Code 551. By placing a point source and camera at the center of curvature of a spherical

---

\* NASA Goddard Space Flight Center, Greenbelt, MD

mirror, a direct measurement of its surface wavefront error is possible. Taking various defocused images at the center of curvature and using an iterative transform solver, the phase error of the reflected wavefront can be determined<sup>3</sup>. From the phase error tip, tilt, defocus, and other Zernike terms (currently truncated to the first 15 terms) can be recovered. This information is used to position the mirror segments. To further develop this approach to phasing mirror segments, the SPOT internal research & development project was started in 2004.

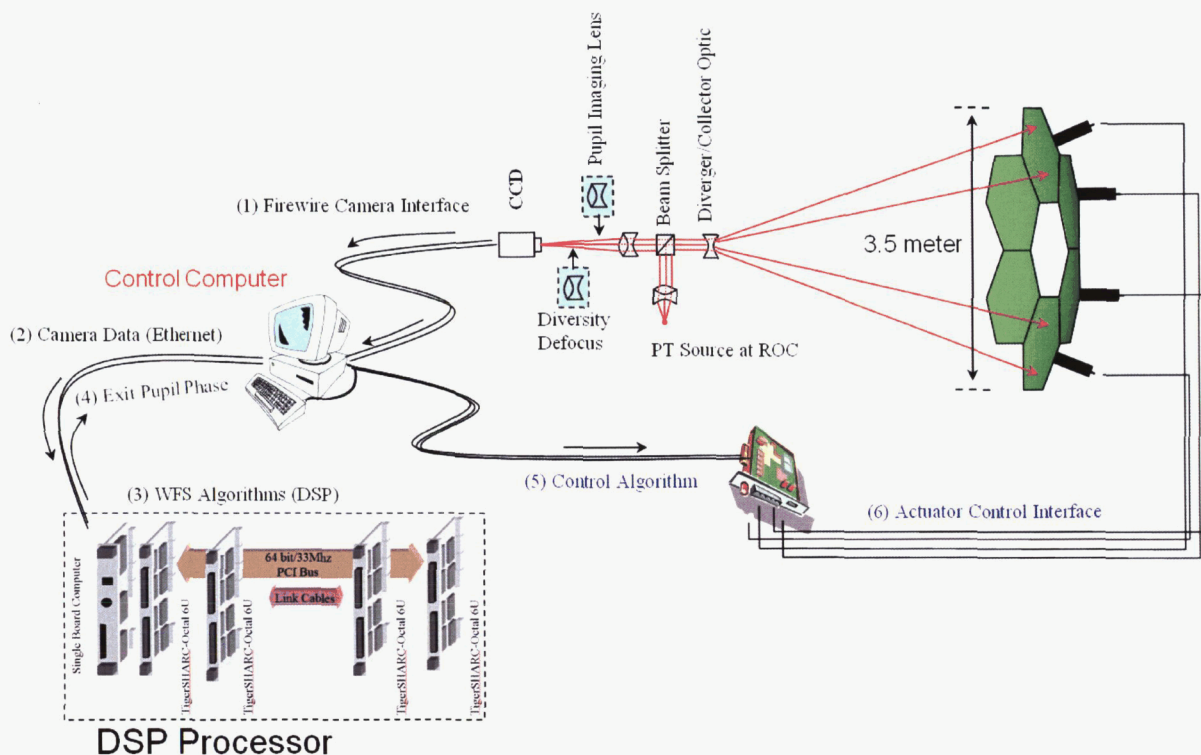

**Figure 2. SPOT Testbed Schematic**

Nanometer-level positioning of ~100-kg mirror segments was required, as well as a high-load nanometer displacement actuator to mechanically bend the mirror segments to adjust their radius of curvature. As the program had limited funding, low-cost actuators were designed to meet these requirements.

### SPOT Background

The Spherical Primary Optical Telescope (SPOT) is a GSFC internal research & development program initiated in 2003. The goal of the SPOT effort is to develop a robust architecture which will reduce the cost of large-aperture, segmented primary mirror space telescopes. The SPOT telescope architecture is based upon two key technology developments: 1) a high-rate, center of curvature, iterative transform phase-diversity phasing algorithm, and 2) a low-cost mirror segment. The SPOT demonstration telescope is a Ø3.5-m segmented spherical primary. The primary consists of 6 identical hexagonal segments measuring 876 mm point-to-point, in a 1-ring configuration, without a central segment. However, only 2 segments are being fabricated for this effort. Two segments are the minimum amount required to successfully demonstrate the phasing architecture. Each segment has rigid-body position control in tip, tilt, and piston. Each segment also has mechanical radius-of-curvature control. Some of the relevant requirements for the SPOT mirror segments are given in Table 1.



**Table 1. Pyrex™ Mirror Segment Requirements**

Mirror Requirement	Value	Units	Note
Size	Ø876 (34.5)	mm (inch)	Point-to-point hex
Radius of curvature (ROC)	5000 ± 0.20	mm	Measured before plating
Figure	1/30	waves@633 nm	ambient
Surface Roughness	40	Angstrom	
ROC adjustment range	±400	microns	
ROC adjustment resolution	1	micron	
Max Surf error for 400 micron ROC adj.	15	nm RMS	
Thermal Operational Environment	20-26	Degrees C	ambient
<b>Rigid Body Motion Requirement</b>			
Focus range	± 5 goal ± 1 min	mm	Needed to provide defocus range
Focus resolution	<10 goal 20 min	nm	Resolution required for phasing
Focus update rate	1	Hz	
Tip/Tilt Range	± 2.0	degree	
Tip/Tilt Resolution	0.05	arcsecond	As allowed by focus resolution
Tip/Tilt update rate	1	Hz	
Position Hold	0	Amp	Power-off hold
Actuator Thermal Stability		Microns/deg	As small as practicable
Static Load	35	kg	Mirror mass ~100 kg, assume 3 actuators

To provide rigid-body positioning in tip, tilt, and defocus of the segments, which will weigh ~50 kg each, a tripod mechanism with custom actuators was designed at GSFC.

### Design of the Segment Assembly Tripod

The mirror segment must have 3 rigid-body degrees of freedom: tip and tilt rotations and piston, a vertical translation. A segment assembly is shown in Figure 3.

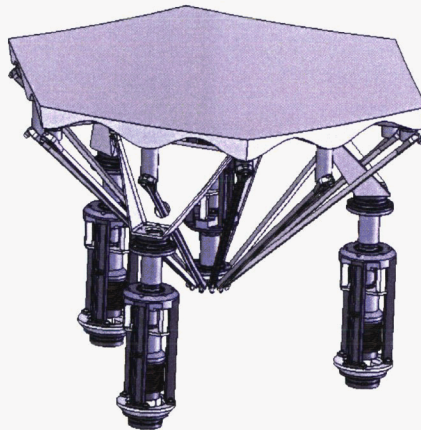

**Figure 3. The SPOT Mirror Segment Assembly Tripod**

### Kinematics of the Segment Assembly & Grübler's Mobility Criterion

The mirror requires only tip tilt and piston adjustment, 3 degrees of freedom. A hexapod would provide 6 degrees of freedom; but we don't need 6. Therefore, a tripod was selected to provide the rigid body motions required. The end joints of each strut must constrain a number of degrees of freedom. For example, a ball-in-socket joint constrains 3 translations but is free to rotate, allowing 3 rotations. From kinematics, Grübler's mobility criterion states that  $F$ , the number of degrees of freedom in a system, can be defined by:

$$F = \lambda(n - j - 1) + \sum_{i=1}^j f_i$$

Where

- $\lambda = 6$ , the degrees of freedom in the space the mechanism will be operating in
- $n$  = the number of links in the system
- $j$  = the number of joints in the system
- $f_i$  = the degrees of freedom allowed (unconstrained) at the  $i^{\text{th}}$  joint

For the SPOT tripod, each leg consists of 2 links and 3 joints. Ground is considered a rigid link, and the mirror is the "end effector" or output link. For this system, the following values are used:

- $\lambda = 6$ , we shall consider the system exists in 6 degrees of freedom
- $n = 8$ , ground and the mirror are each one link, and each leg has 2 links
- $j = 9$ , each leg has 3 joints (base, linear, and upper) x 3 legs
- $f_1 = 2$ , base joint of leg 1, XY flexure allowing 2 rotations
- $f_2 = 2$ , base joint of leg 2, XY flexure allowing 2 rotations
- $f_3 = 2$ , base joint of leg 3, XY flexure allowing 2 rotations
- $f_4 = 1$ , linear joint of leg 1, allowing 1 translation
- $f_5 = 1$ , linear joint of leg 2, allowing 1 translation
- $f_6 = 1$ , linear joint of leg 3, allowing 1 translation
- $f_7 = 2$ , upper joint of leg 1, XY flexure allowing 2 rotations
- $f_8 = 2$ , upper joint of leg 2, XY flexure allowing 2 rotations
- $f_9 = 2$ , upper joint of leg 3, XY flexure allowing 2 rotations

Using the above values, the system degrees of freedom are calculated as:

$$F = 6(8 - 9 - 1) + \sum_{i=1}^9 f_i = 3$$

The number of system degrees of freedom is 3, corresponding to tip, tilt and piston. The use of XY flexures, allowing  $f_i$  (for  $i = 1..3, 7..9$ ) = 2, is justified. Ball joints could be used, but the additional passive degree of freedom at each leg (roll) would have to be subtracted out of the Grübler criterion equation to keep  $F = 3$ . The XY flexures will allow hysteresis-free angular motion at the cost of increased force proportional to displacement.

### **Actuator Design**

The actuator is shown in Figure 4.



**Figure 4. The SPOT linear actuator, shown with a six-inch ruler for scale.**

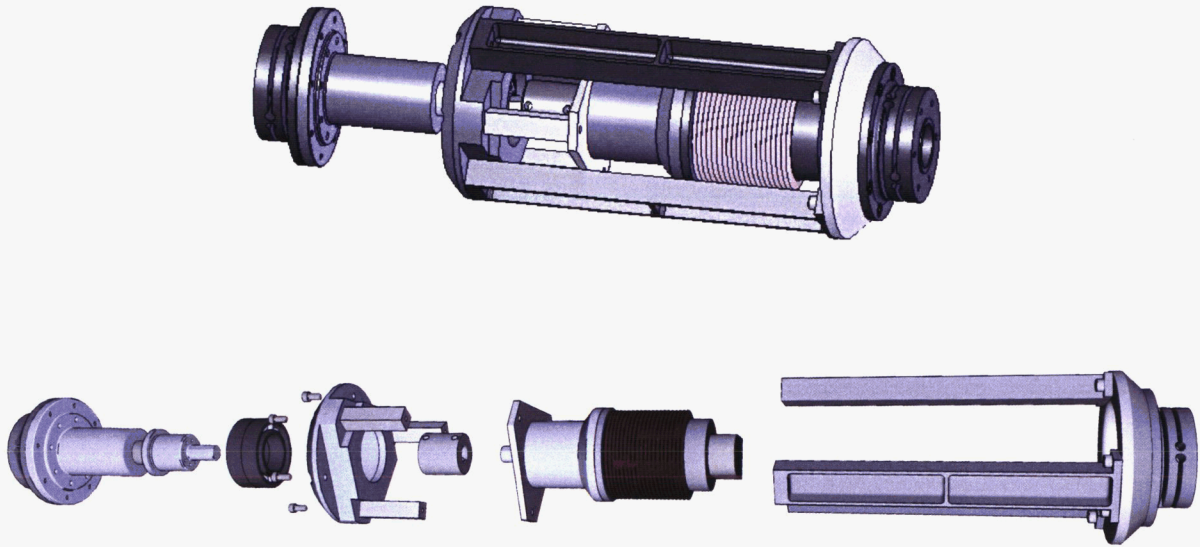

**Figure 5. An exploded view of the SPOT linear actuator**

Stepper Motor/Harmonic Drive Gearhead

ZSS 52.500.2.5.K1-HEDL-HD14/100

The HD14 100:1 harmonic Drive gearhead

Phyton 500 step per revolution or 0.72 degree step size

3-phase stepper motor, 2.5 Amp winding

Agilent HEDL 5540 500 line (A quad B = 2000 counts) incremental encoder on motor output



**Figure 6. The Phytron ZSS 52 / HD14 actuator**

Differential Satellite Roller Screw

Several options exist for rotary-to-linear motion: lead screw, ball screw, or roller screw. Generally the most precise of these is the satellite roller screw. A differential roller screw was selected. After several months of vendor interaction, a differential roller screw was selected and sized. The smallest, readily available precision roller screw has a pitch of 0.5 mm. A lead of this size can produce 10 nm steps using the 0.72° stepper motor and 100:1 harmonic drive.

Using a differential roller screw, the effective lead can be reduced by 2 orders of magnitude, but at the cost of a stroke limitation to ~6 mm. The theoretical attainable step size drops to 0.4 nm (see below). A Rollvis™ differential satellite roller screw utilizes equal thread pitch on the nut and the shaft, but varies the nut/shaft thread pitch diameters and the number of starts on the nut and shaft. The effective lead of such a differential satellite roller screw can be calculated by:

$$L_{eff} = \frac{P(D_n N_s + D_s N_n)}{D_n + D_s}$$

Where

- D<sub>n</sub> = Nut thread pitch diameter, mm
- D<sub>s</sub> = Shaft thread pitch diameter, mm
- P = thread pitch in threads/mm
- N<sub>n</sub> = number of thread starts on nut
- N<sub>s</sub> = number of thread starts on shaft, negative for opposite handedness to nut starts

For the SPOT actuator, the values were varied within reasonable limits until a minimum value for effective lead was found. Using the following values:

- D<sub>n</sub> = 29 mm
- D<sub>s</sub> = 19 mm
- P = 0.5 threads/mm
- N<sub>n</sub> = 4
- N<sub>s</sub> = -6

$$L_{eff} = \frac{0.5[(29)(-6) + (19)(4)]}{29 + 19} = 0.02mm$$



The minimum effective lead,  $L_{eff}$ , was found to be 0.02 mm per revolution, or ~21 microns per revolution. A bind condition determines the total stroke, which for this differential roller screw is ~6 mm. Rollvis Swiss S.A., a Swiss manufacturer of precision roller screws, fabricated the roller screw as Model RV160/19,02.R1.604350, custom designed for maximum resolution.

The 5 rollers roll around the shaft and are held in a rotating retainer ring at each end of the nut. A sun gear at each end of the nut and mating roller gears at the ends of each roller keep them in proper clocking as they rotate around the shaft. The shaft, nut and rollers are 410 stainless steel. The lubricant for the roller screw is Isoflex Topas NCA 52, manufactured by Klüber Lubrication. It is a synthetic oil with a calcium thickener. The differential satellite roller screw is shown in Figure 7 and 8.



**Figure 7. Custom Differential Satellite Roller Screw**

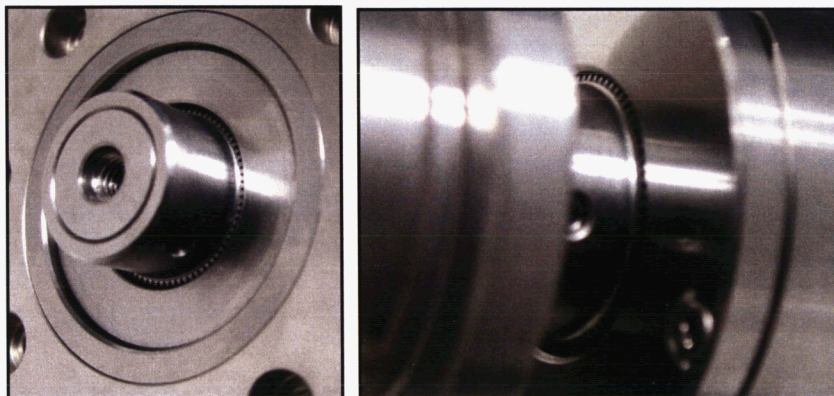

**Figure 8. Nut end details showing the timing gear teeth**

#### Helical Coupling

A standard flexible shaft coupling from Helical Products Company, Inc. was used to couple the motor output shaft to the satellite roller screw shaft. Such couplers allow torque to be transmitted despite small axial misalignments between the shafts. A model HRM-125-12mm-12mm coupling was used. This coupler uses 2 pairs of cup-point set screws to secure the motor and screw shafts. The coupling is 17-4PH H900 stainless steel. The coupling is shown in Figure 9.



**Figure 9. Helical Coupling**

Bearings

Barden 106HCDUL back to back duplex pair, ABEC-9, SAE52100 steel  
 30-mm bore diameter, 15-degree contact angle, 14 7.14-mm (9/32") diameter 440C balls, 36-kg (80-lb) heavy preload  
 Static load capacity 1005 kg (2216 lb)  
 Machined phenolic cage retainer  
 Winsorlube L245X oil lubricant



**Figure 10. Barden 106HC Duplex bearing pair**

Leg End Flexures

XY flexures  
 Crossed flexure  
 Torsional rate  
 Fatigue/cycle life



$$K = \frac{9\pi r^{0.5}}{2Ebt^{2.5}}$$

Where

K = torsional spring rate  
r = radius of notch cut  
E = Modulus  
b = thickness of flexure section  
t = width of notch

For the SPOT tripod, each leg consists of 2 links and 3 joints. Ground is considered a rigid link, and the mirror is the "end effector" or output link.

### Conclusion

Further testing to fully characterize nanometric step size, repeatability, and linearity must be accomplished in a quiet facility. The actuator performance will also be measured with an actuator built into a mirror segment. Actuator positioning performance will be indirectly measured by mirror radius of curvature change per commanded step.

### References

1. Budinoff, Jason G. "SPOT Mirror Segment Assembly Requirements - Revision C", March 2004
2. Howard, Joseph "Optical Design Study for NASA's Spherical Primary Optical Telescope" SPIE 5524-1
3. Budinoff, Jason G, Michels, Gregory J. "Design & Optimization of the Spherical Primary Optical Telescope (SPOT) Primary Mirror Segment" SPIE 5877-42
4. Dean, B, Smith, S, Budinoff, J. "Image-Based Wavefront Sensing for the Control of Space Optics" USAF AMOS Maui Technical Conference, September, 2000
5. Chanan, G., Troy, M., Ohara, C. "Phasing the Primary Mirror Segments of the Keck Telescopes: A Comparison of Different Techniques" Proc. SPIE, 4003, 188-201, 2000
6. Martinez, L.M., Yaitskova, N., Dierickx, P., Dohlen, K. "Mach Zender Wavefront Sensor for Phasing Segmented Telescopes"
7. Tsai, Lung-Wen, 'Robot Analysis: The Mechanics of Serial and Parallel Manipulators' ©1999 John Wiley & Sons, Inc.
8. Paros, J.M., Weisbord, I. "How to Design Flexure Hinges" Machine Design vol 37, pp151-156, 1965
9. Lobontiu, Nicolae "Compliant Mechanisms: Design of Flexure Hinges" ©2002 CRC Press LLC