

## UWB Tracking System Design with TDOA Algorithm

### Abstract

This presentation discusses an ultra-wideband (UWB) tracking system design effort using a tracking algorithm TDOA (Time Difference of Arrival). UWB technology is exploited to implement the tracking system due to its properties, such as high data rate, fine time resolution, and low power spectral density. A system design using commercially available UWB products is proposed. A two-stage weighted least square method is chosen to solve the TDOA non-linear equations. Matlab simulations in both two-dimensional space and three-dimensional space show that the tracking algorithm can achieve fine tracking resolution with low noise TDOA data. The error analysis reveals various ways to improve the tracking resolution. Lab experiments demonstrate the UWB-TDOA tracking capability with fine resolution. This research effort is motivated by a prototype development project Mini-AERCam (Autonomous Extra-vehicular Robotic Camera), a free-flying video camera system under development at NASA Johnson Space Center for aid in surveillance around the International Space Station (ISS).

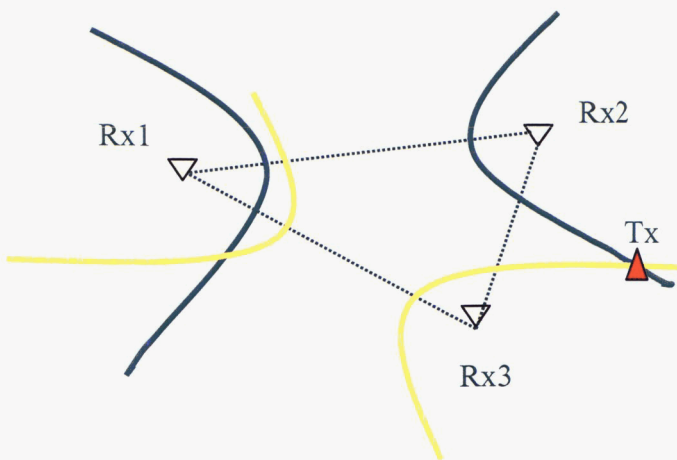

Figure 1. TDOA Tracking Algorithm

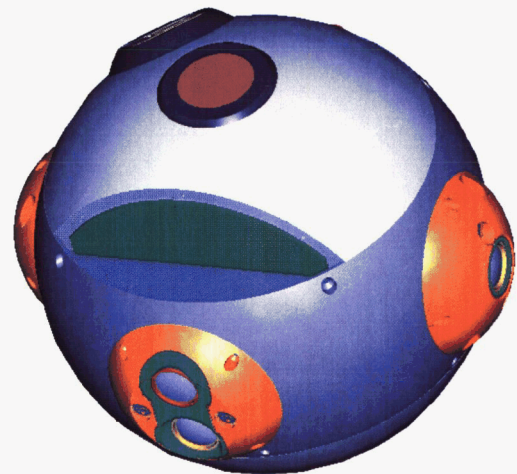

Figure 2. Mini-AERCam

# UWB Tracking System Design with TDOA Algorithm



David (Jianjun) Ni

**Collaborators:** Dickey Arndt, Phong Ngo, Chau Phan,  
Julia Gross, John Dusl, Alan Schwing

NASA Johnson Space Center

*This research was performed while the author held a National Research Council  
Research Associateship Award at NASA Johnson Space Center.*



# Outline

- ✚ Introduction to Mini-AERCam
- ✚ UWB Fine Time Resolution
- ✚ Tracking Principle
- ✚ TDOA Tracking Algorithm
- ✚ Tracking Simulation Demo
- ✚ Laboratory Experiment
- ✚ Conclusion and Future Work

## AERCam Sprint (STS-87, 1997)

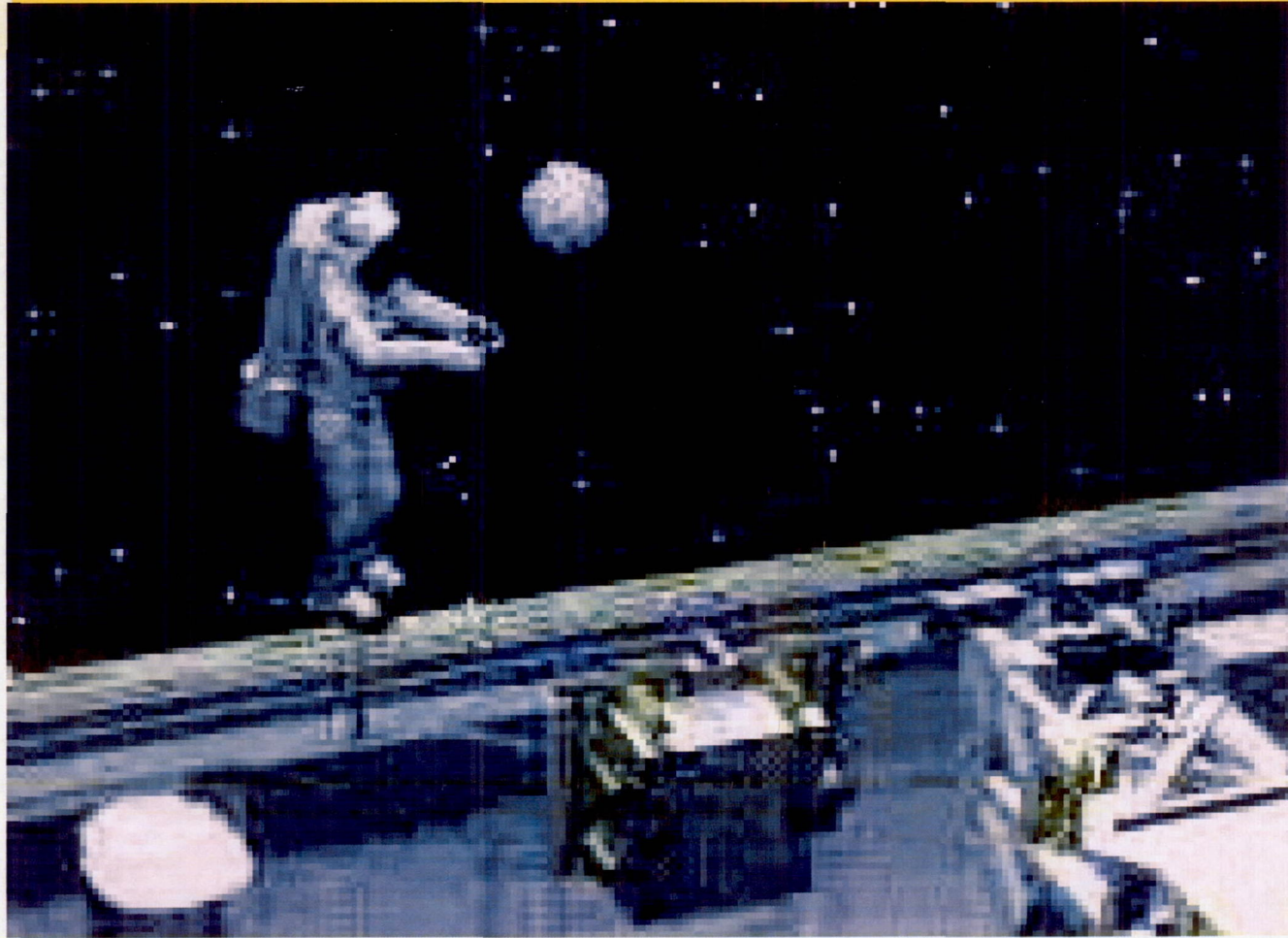

# Mini-AERCam (RF tracking)

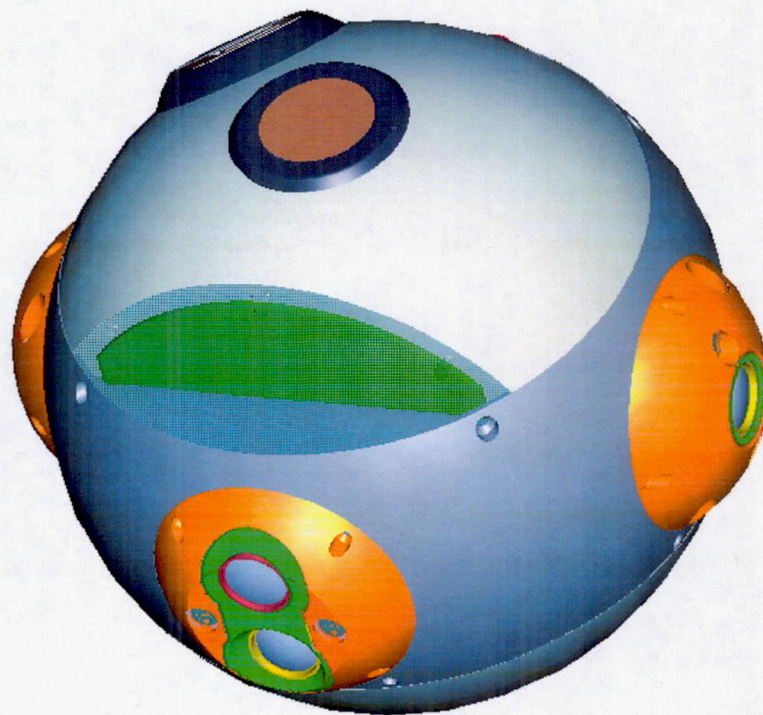

# System Design (Block Diagram)

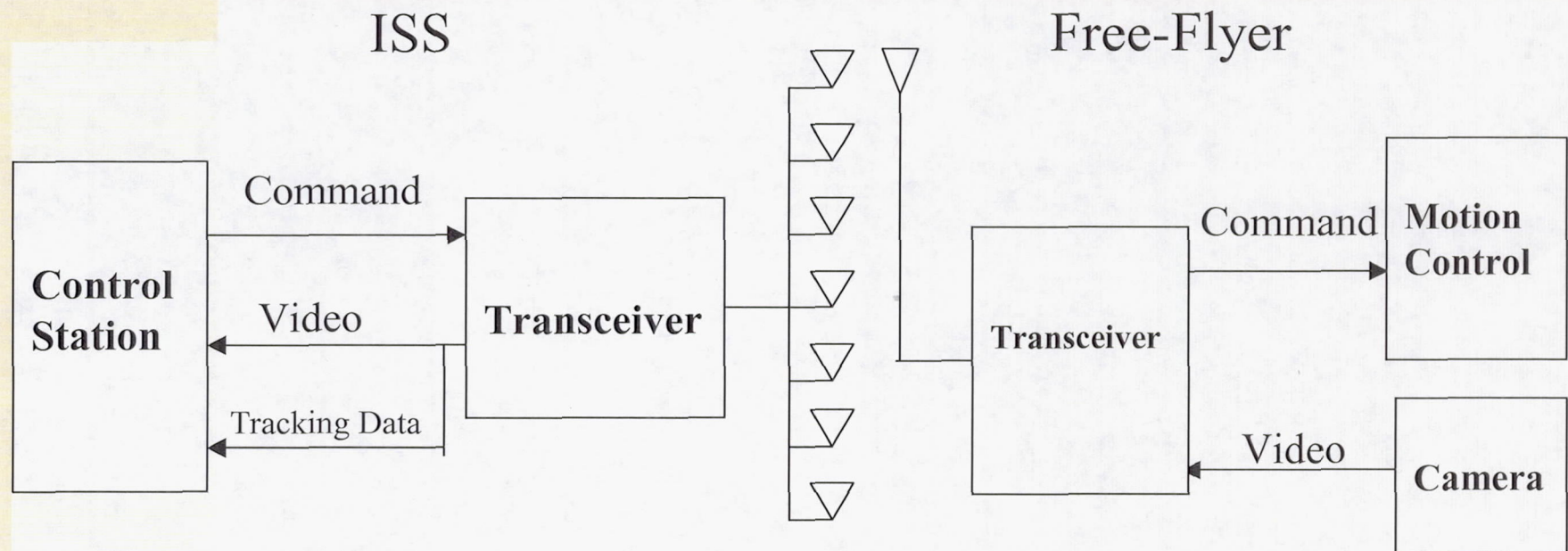

- ✦ To transmit commands from ISS to free-flyer for navigation (downlink).
- ✦ To transmit real-time data (video, telemetry) from free-flyer to ISS (uplink).
- ✦ To passively track the free-flyer using telemetry data

## What is UWB ? (FCC Definition)

A ultra wideband device is defined as any device where the fractional bandwidth is **greater than 0.20** or occupies **500 MHz or more** of spectrum.

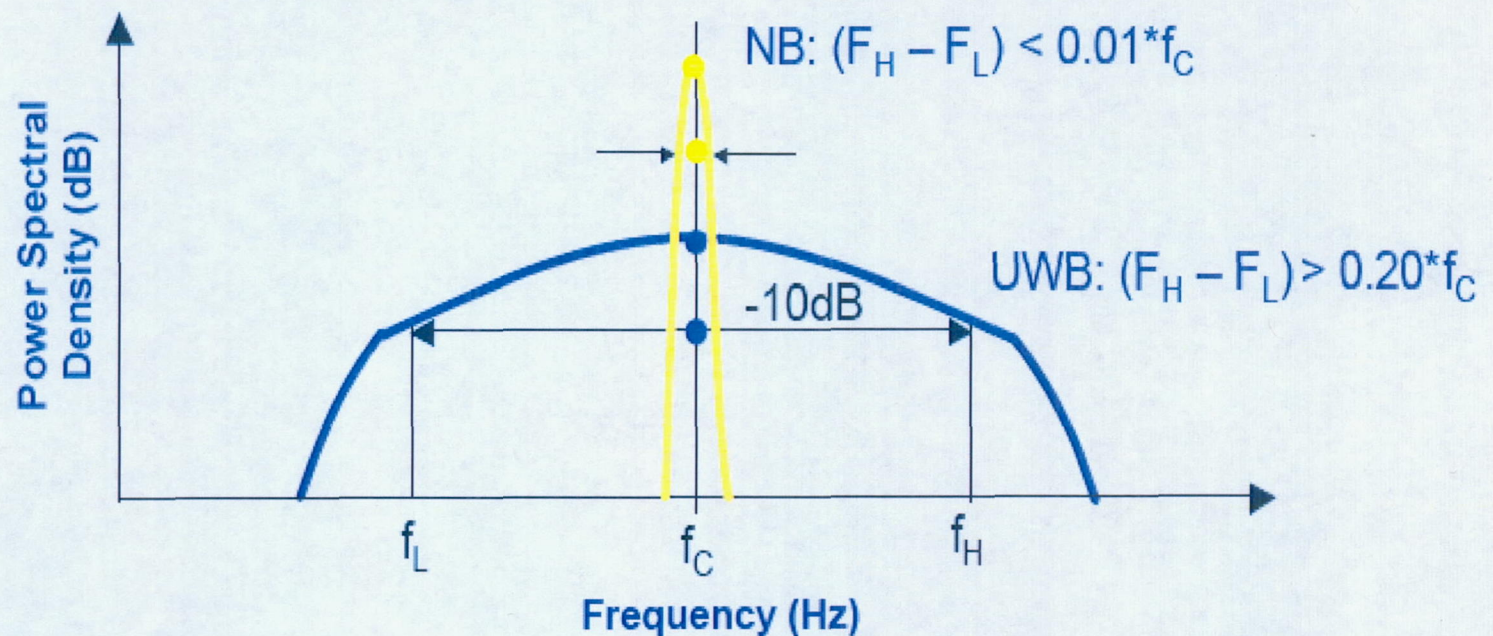

# UWB Pulse in Time and Frequency Domain

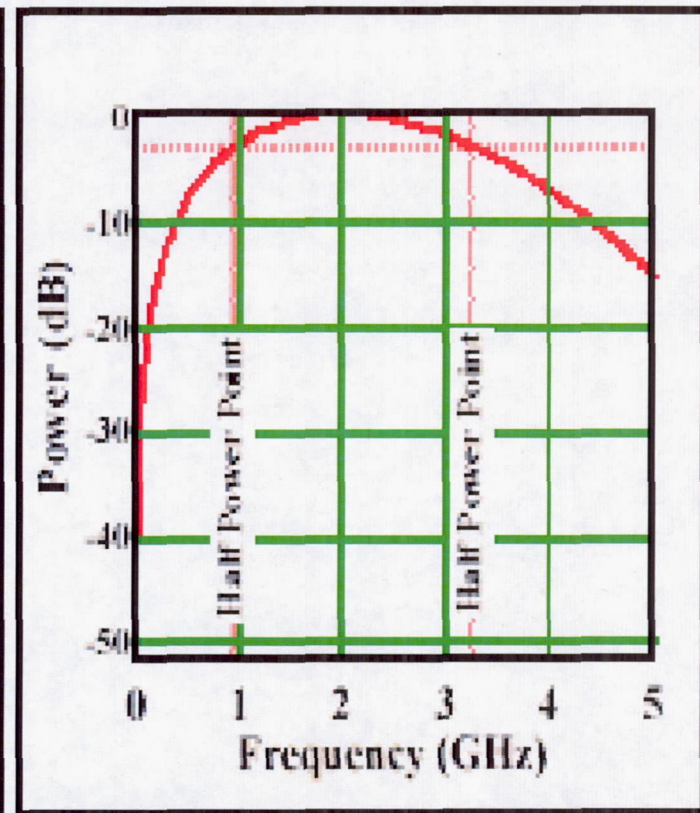
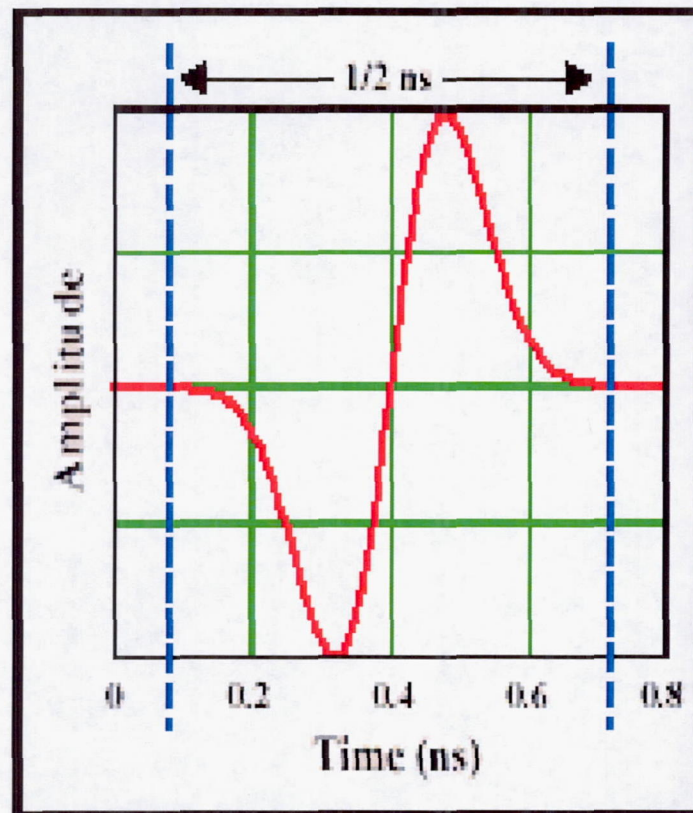



# UWB Fine Time Resolution

## Sinusoidal, Narrowband

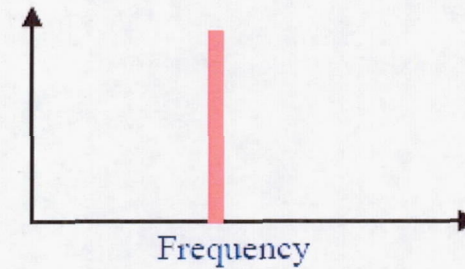
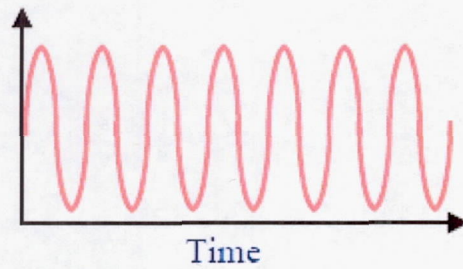

## Impulse, Ultra-Wideband

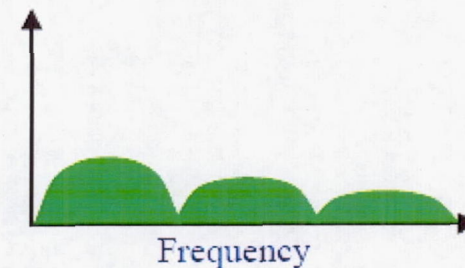
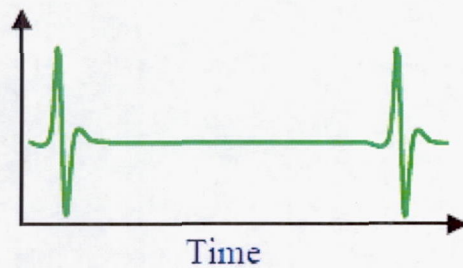



## Time Resolution vs. Range Resolution

### ✦ Time vs. Distance Resolution

- 1ns  $\Leftrightarrow$  0.3m (1 foot)
- 1ps  $\Leftrightarrow$  0.3 mm
- 30ps  $\Leftrightarrow$  1cm (Leading Edge Detection)

# Time of Arrival (TOA)

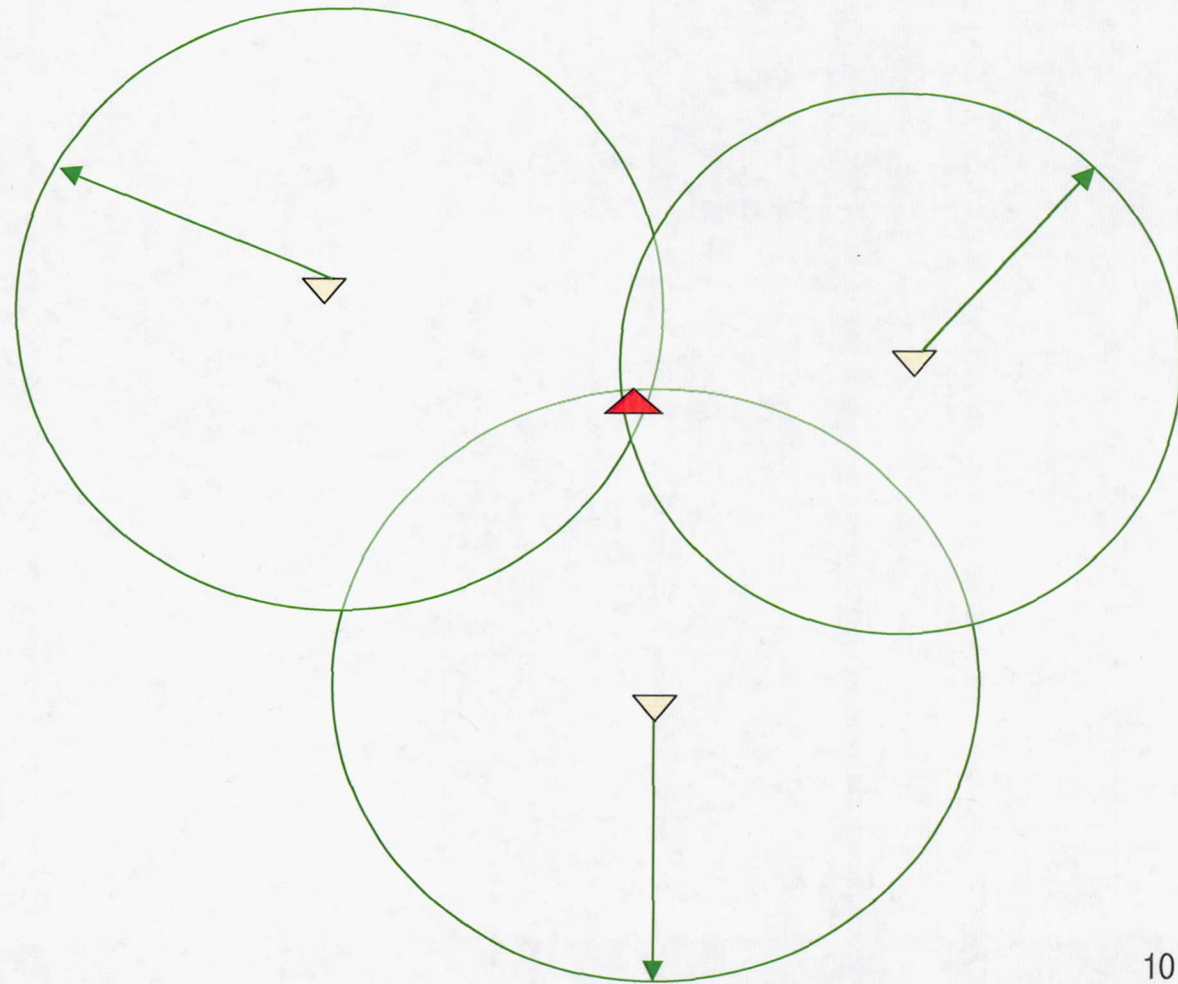



## Drawbacks of TOA

- ✦ Ranging: requires duplex transmission and incurs overhead (Asynchronization)
- ✦ Synchronization: hard to achieve the synchronization precision between the transmitter and receiver ; 1microsecond synchronization error can easily translate into 300 meters of range error

# Time Difference of Arrival (TDOA)

Hyperbola:  $b^2 x^2 - a^2 y^2 = a^2 b^2$

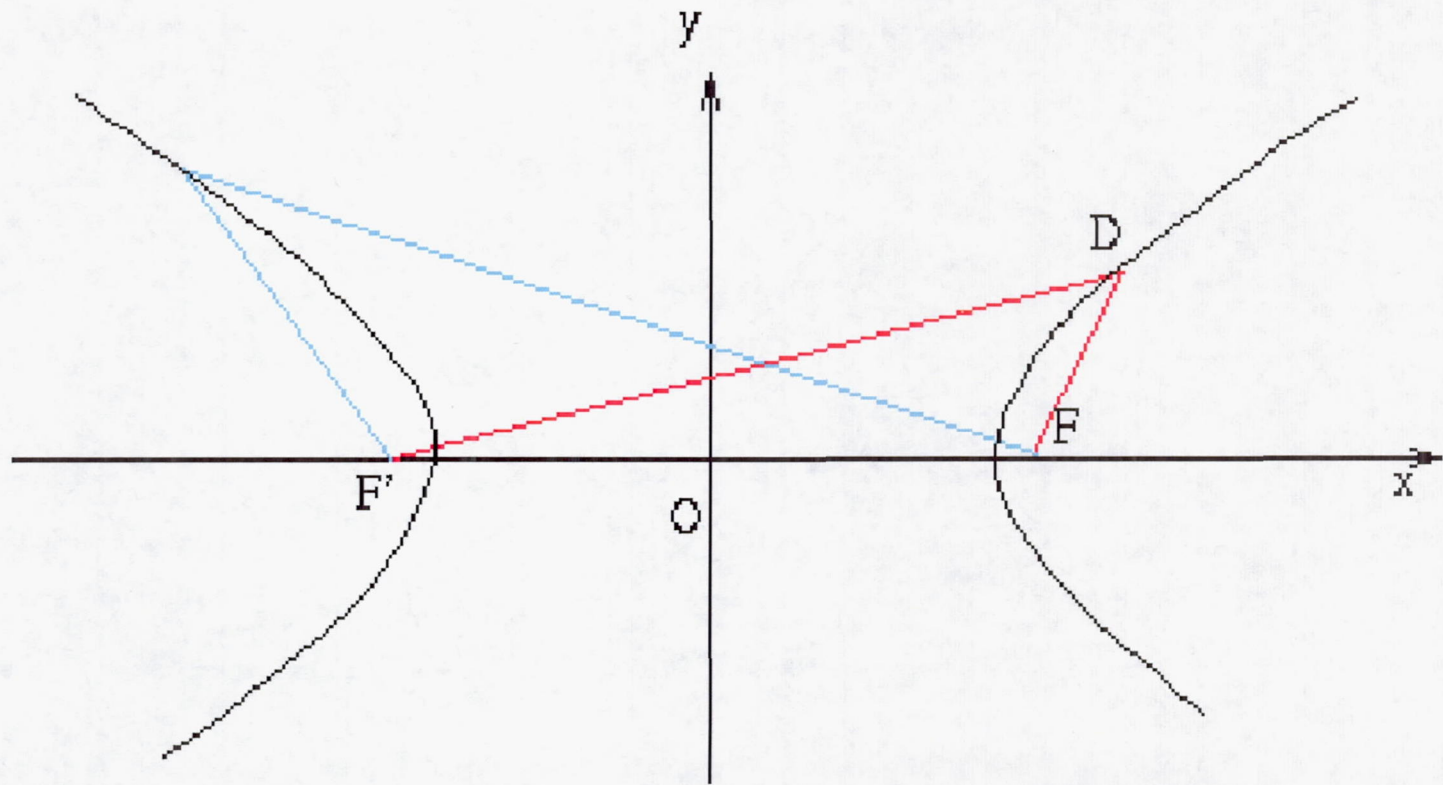

# Time Difference of Arrival (TDOA)

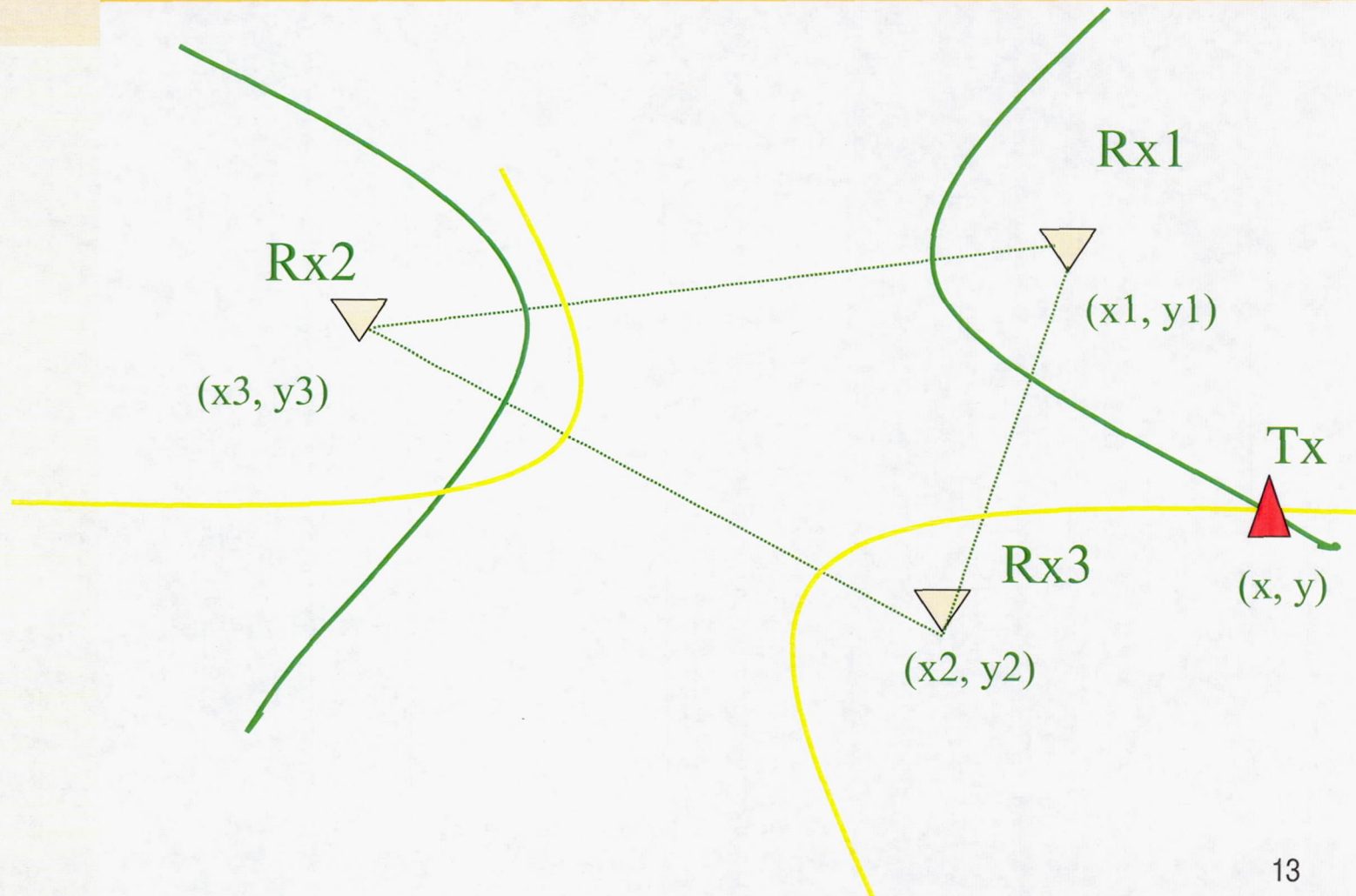



# Advantages of TDOA

- ✦ No synchronization between Tx and Rx
- ✦ Simplex (one-way) data estimation

## TDOA Equations

$$D_{12} = \sqrt{(x_1 - x)^2 + (y_1 - y)^2} - \sqrt{(x_2 - x)^2 + (y_2 - y)^2} = \tau_{12}c$$

$$D_{13} = \sqrt{(x_1 - x)^2 + (y_1 - y)^2} - \sqrt{(x_3 - x)^2 + (y_3 - y)^2} = \tau_{13}c$$

$$D_{23} = \sqrt{(x_2 - x)^2 + (y_2 - y)^2} - \sqrt{(x_3 - x)^2 + (y_3 - y)^2} = \tau_{23}c$$



## Taylor Series Expansion Non-linear Least Squares (NLLS) Iterative Algorithm

$$f_k(x, y) = f_k(x_0, y_0) + \frac{\partial f_k}{\partial x}(x - x_0) + \frac{\partial f_k}{\partial y}(y - y_0)$$

$$\mathbf{A} \mathbf{p}_T = \mathbf{b}$$

$$\mathbf{A} = \begin{bmatrix} \frac{\partial f_1}{\partial x} & \frac{\partial f_1}{\partial y} \\ \vdots & \vdots \\ \frac{\partial f_K}{\partial x} & \frac{\partial f_K}{\partial y} \end{bmatrix} \quad \mathbf{p}_T = \begin{bmatrix} (x - x_0) \\ (y - y_0) \end{bmatrix} \quad \mathbf{b} = \begin{bmatrix} r_1 - f_1(x_0, y_0) \\ \vdots \\ r_K - f_K(x_0, y_0) \end{bmatrix}$$

$$\hat{\mathbf{p}}_T = (\mathbf{A}^T \mathbf{A})^{-1} \mathbf{A}^T \mathbf{b}$$



## Two-Stage Weighted LS Algorithm

- ✚ No Initialization Problem (no first guess)
- ✚ No Convergence Problem (always converges)
- ✚ No Iteration Problem (low computation cost)
- ✚ Achieved Cramer-Rao Lower Bound (optimal estimator)
- ✚ No Free Lunch (need one more receiver)



# Tracking Simulation Demo

- ✦ Random Tracking
- ✦ Orbit Tracking
  1. TDOA Estimation Noise Level (std=0.01)
  2. TDOA Estimation Noise Level (std=0.001)
  3. TDOA Estimation Noise Level (std=0.0001)
- ✦ Receiving Antenna Configuration
- ✦ 3D Orbit Tracking

# Random Tracking

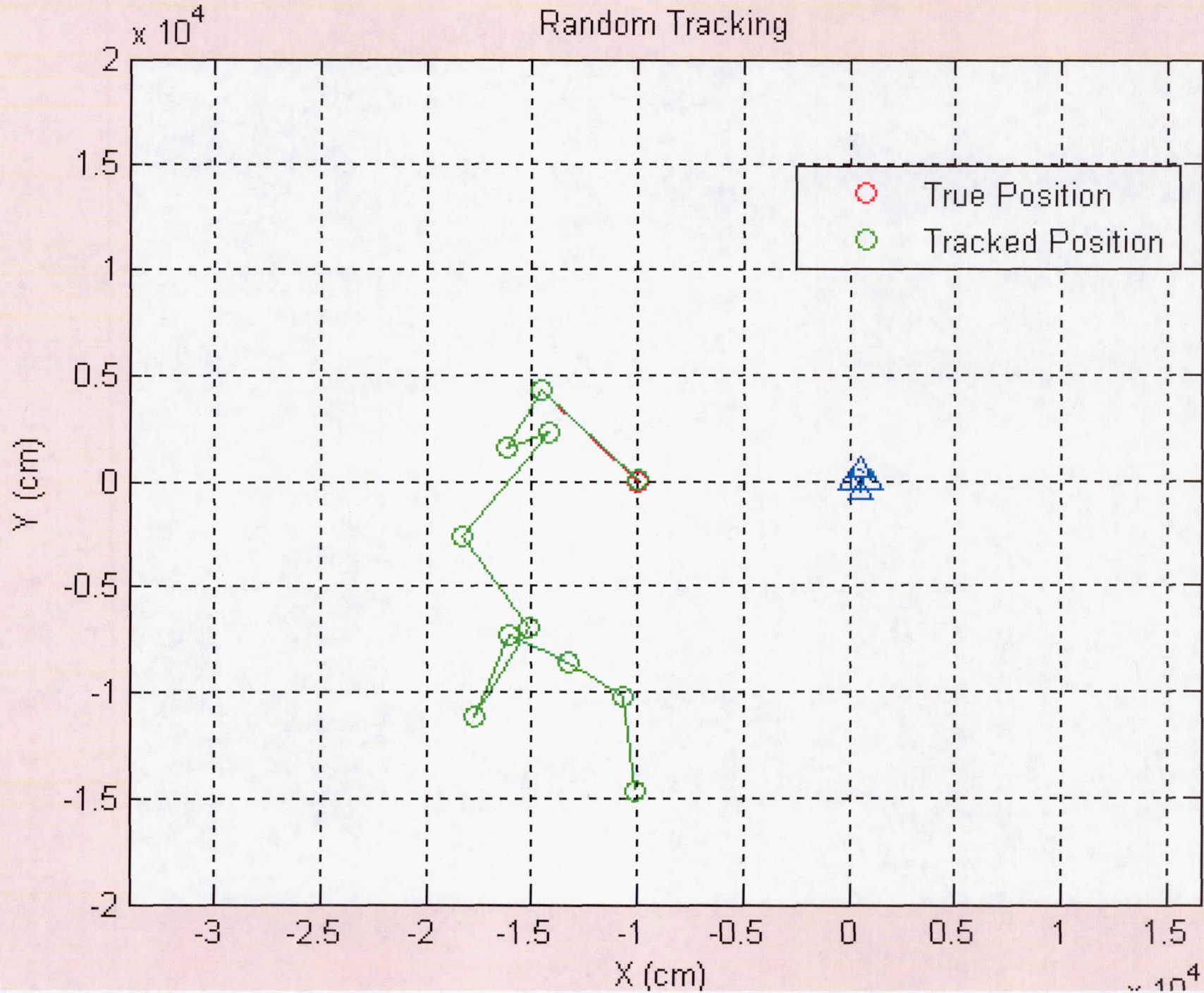

TDOA Noise Level (std=0.01)

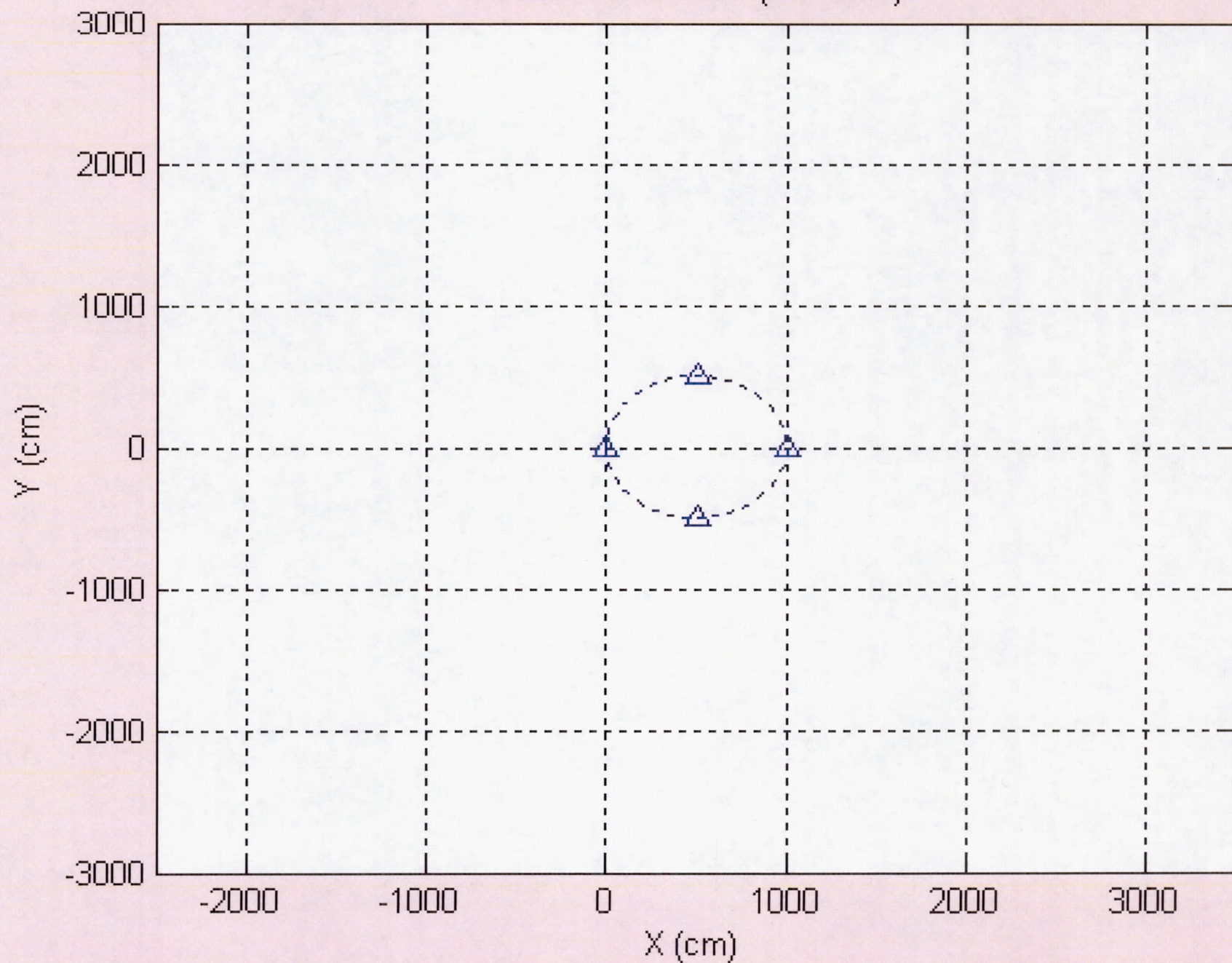

TDOA Noise Level (std=0.01)

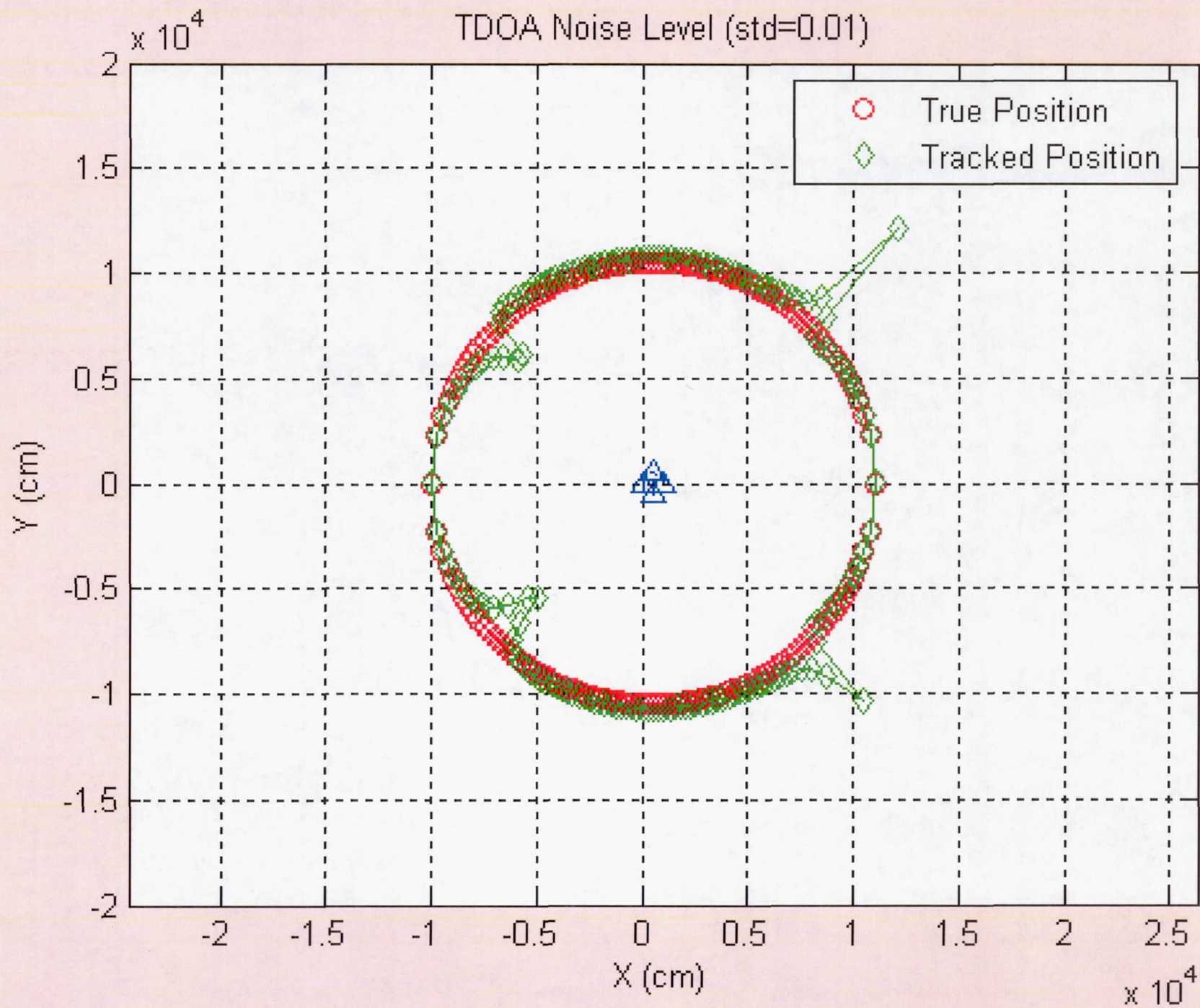

Error Analysis (std=0.01)

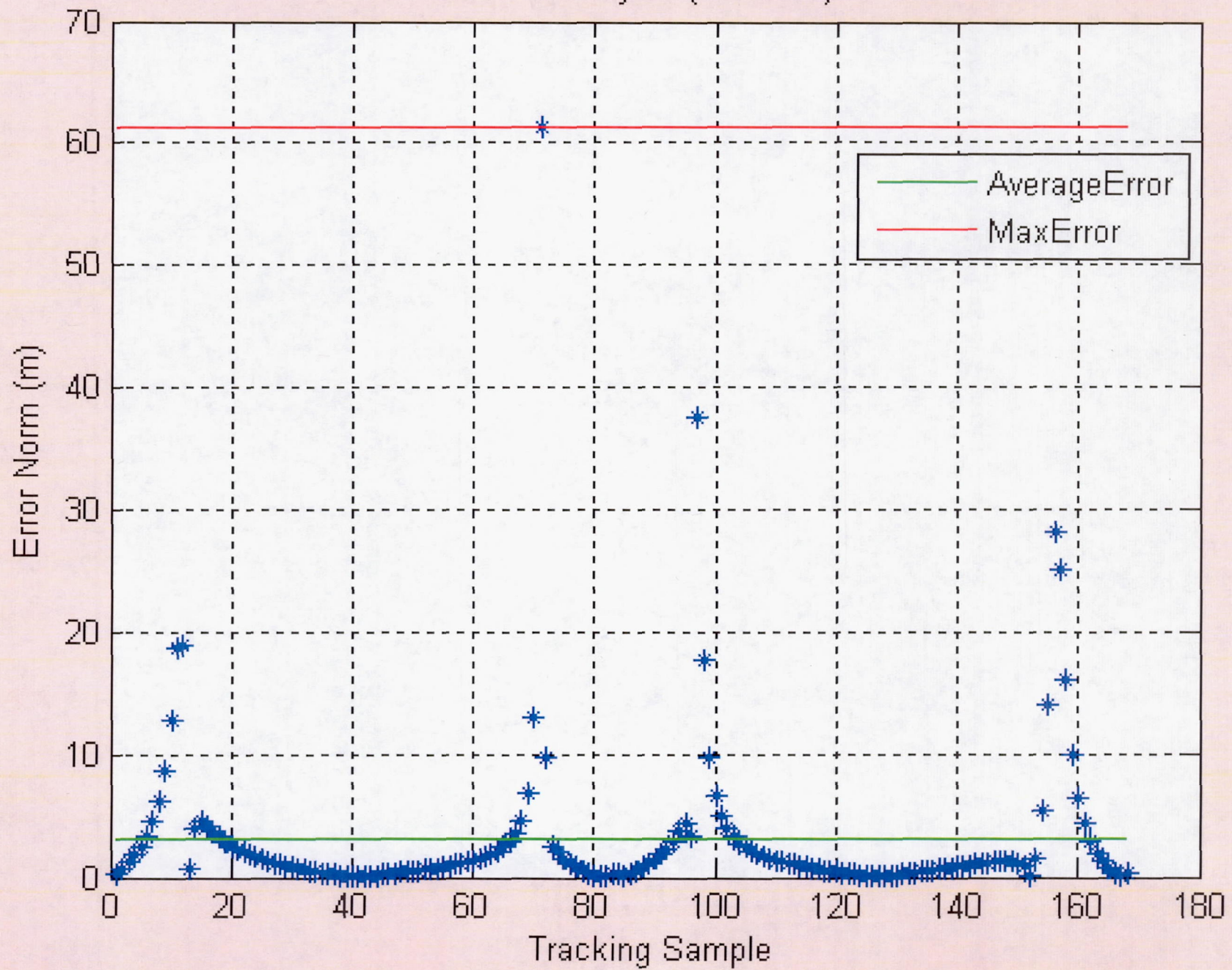

TDOA Noise Level (std=0.001)

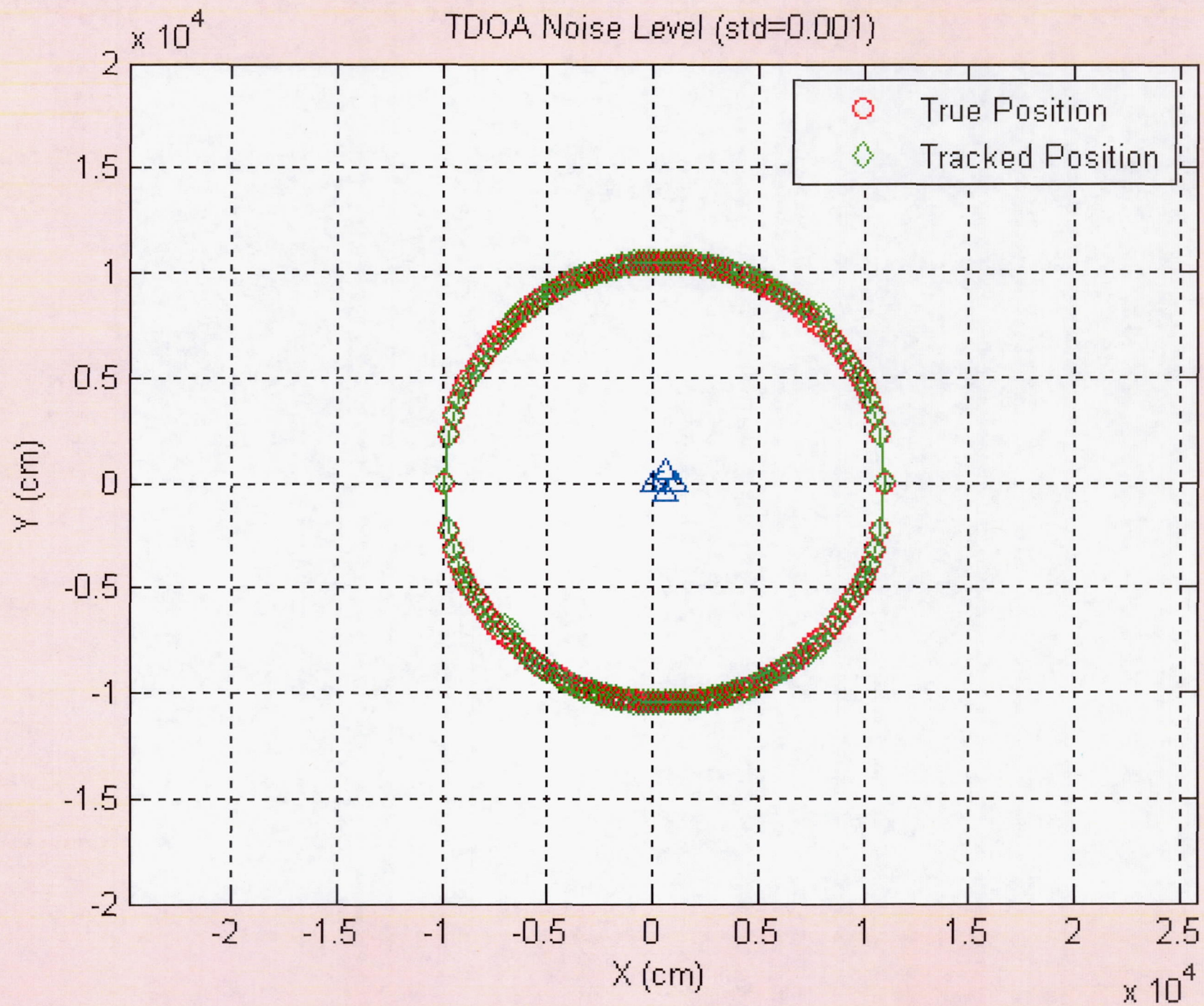



Error Analysis (std=0.001)

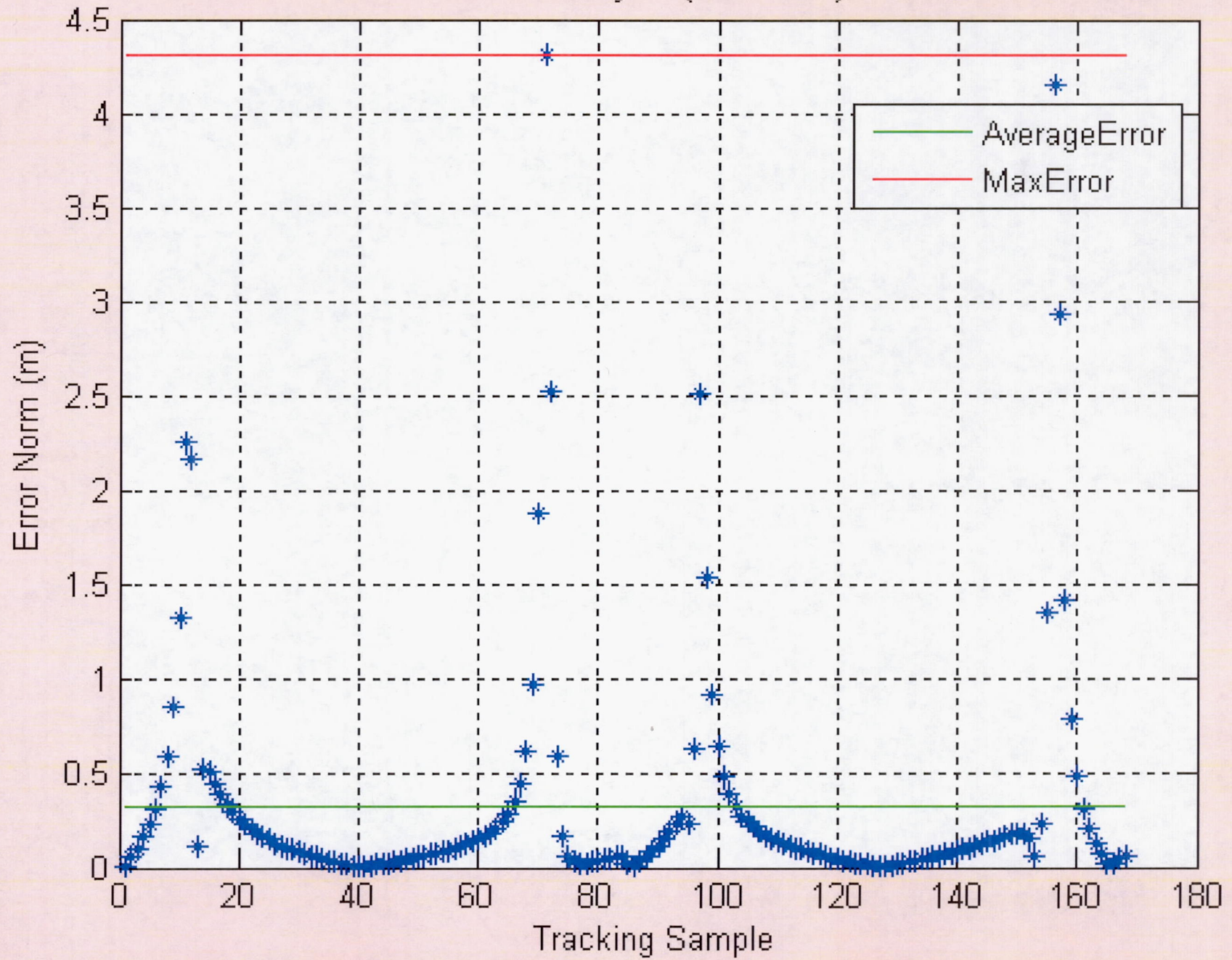

TDOA Noise Level (std=0.0001)

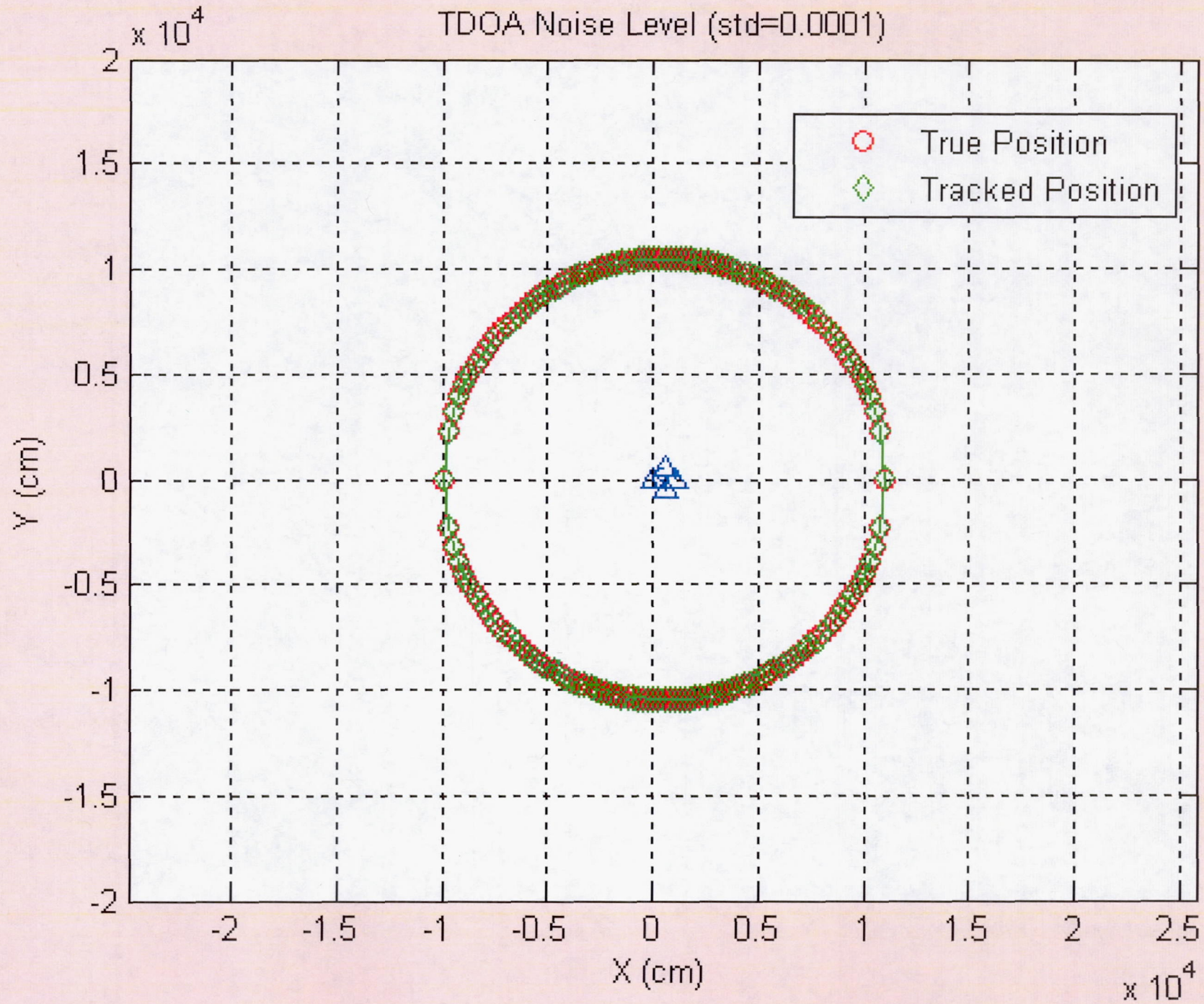

Error Analysis (std=0.0001)

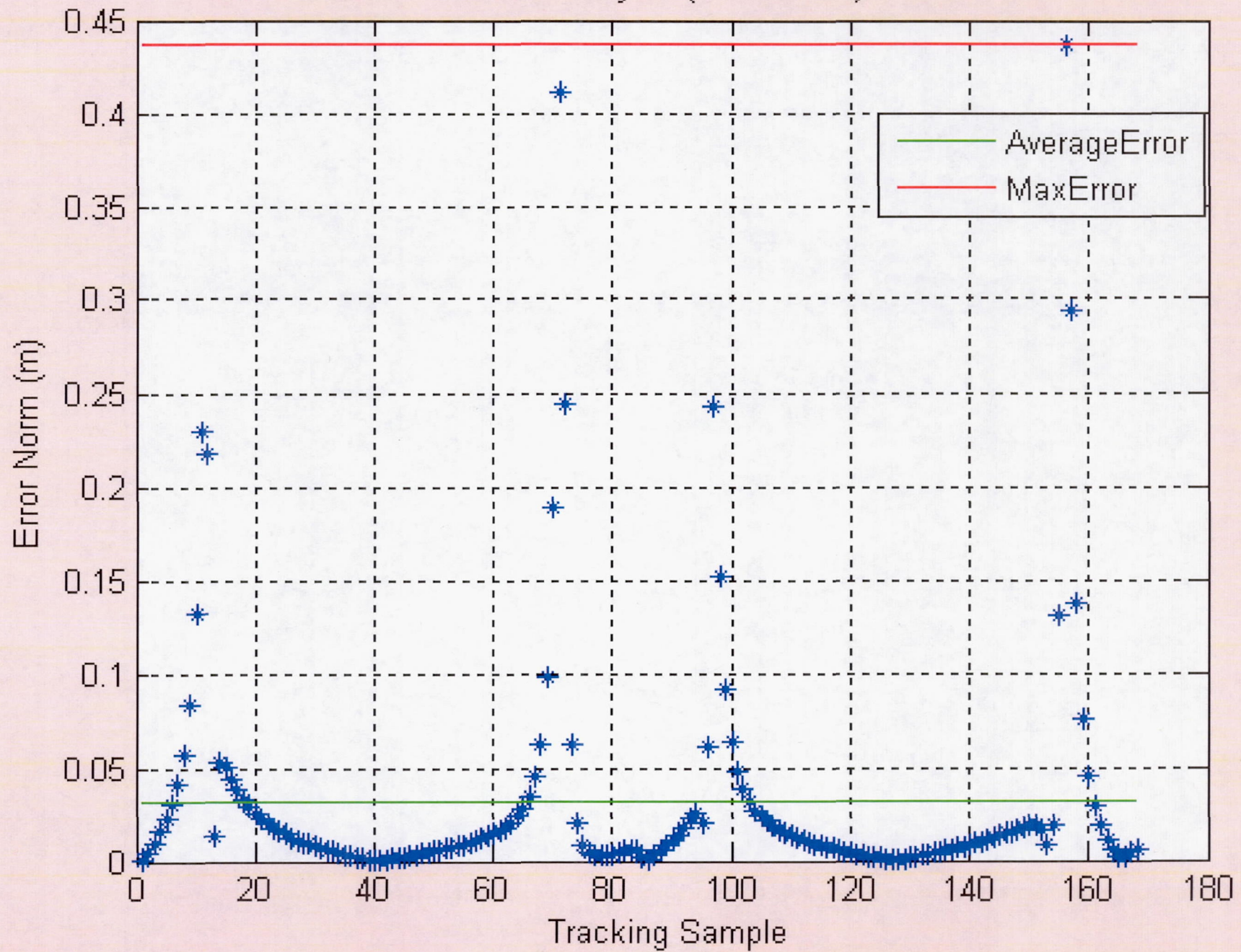

## Error Analysis

<b>Standard Deviation of TDOA (ns)</b>	<b>Maximum Error (m)</b>	<b>Average Error (m)</b>
<b>0.01</b>	<b>61.3271</b>	<b>3.1372</b>
<b>0.001</b>	<b>4.3110</b>	<b>0.3172</b>
<b>0.0001</b>	<b>0.4366</b>	<b>0.0317</b>

- The tracking error is linear to the standard deviation of TDOA data

Antenna Configuration (std=0.01)

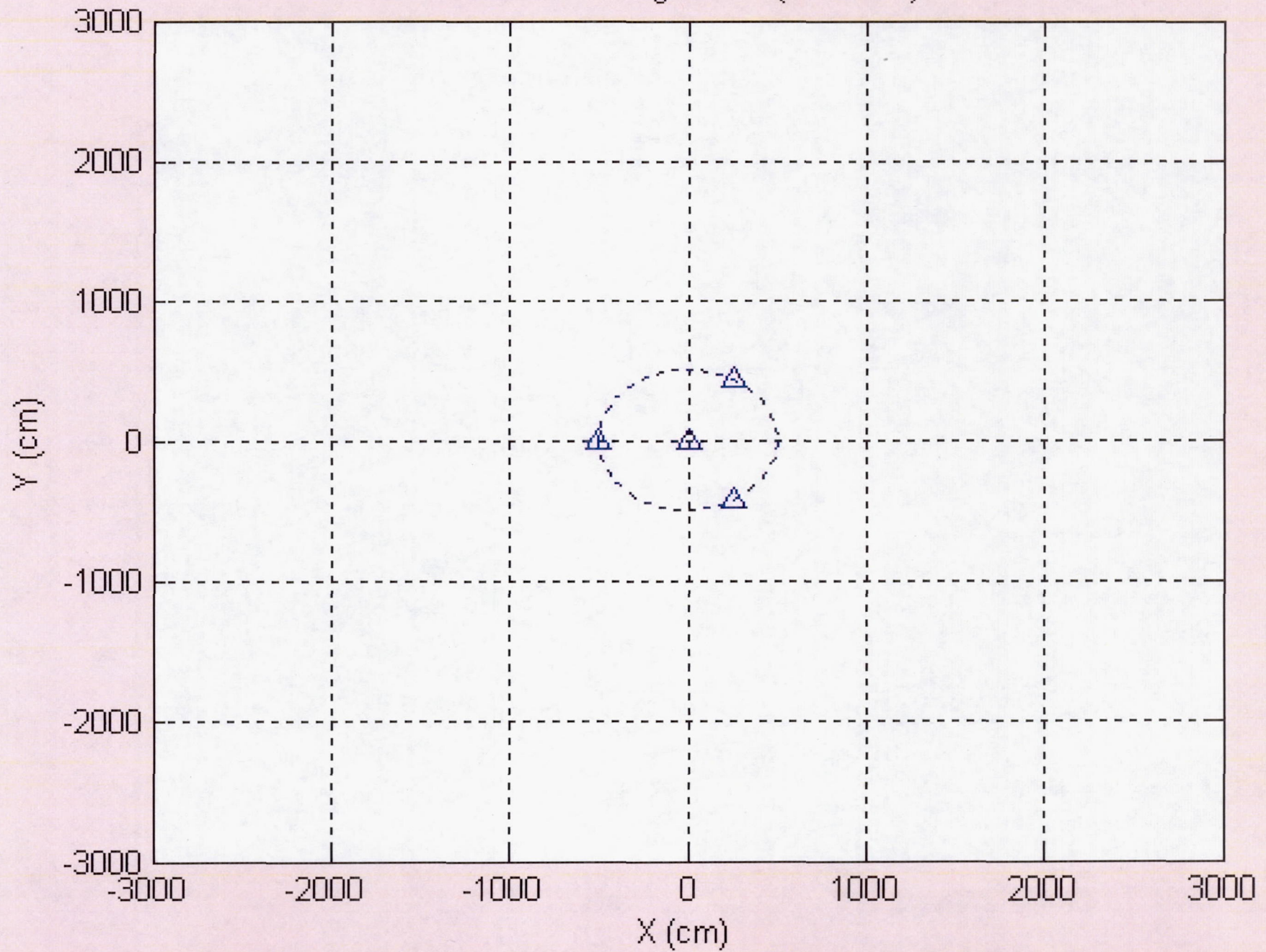

Antenna Configuration (std=0.01)

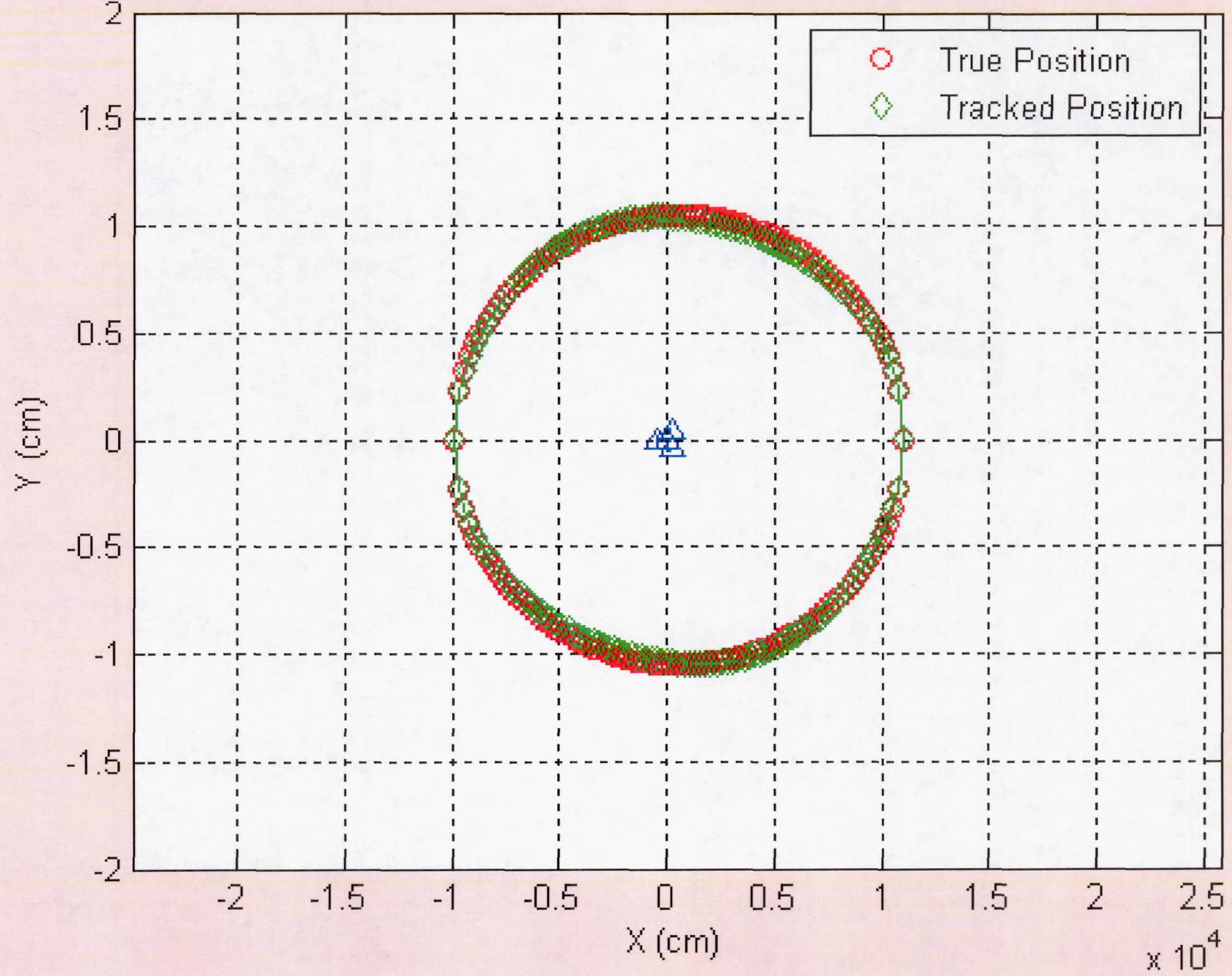

Error Analysis (std=0.01)

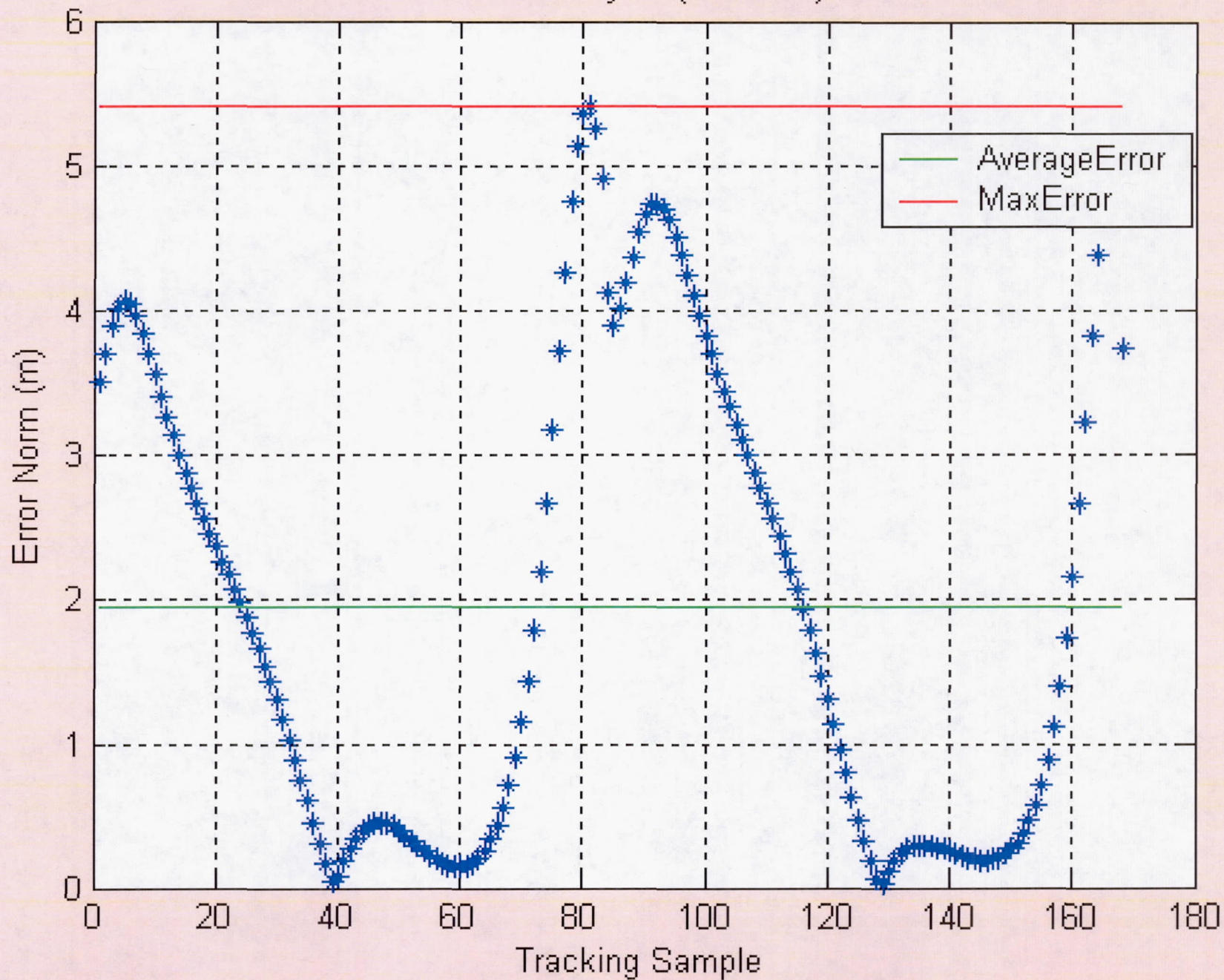

# UWB 3D Tracking Simulation

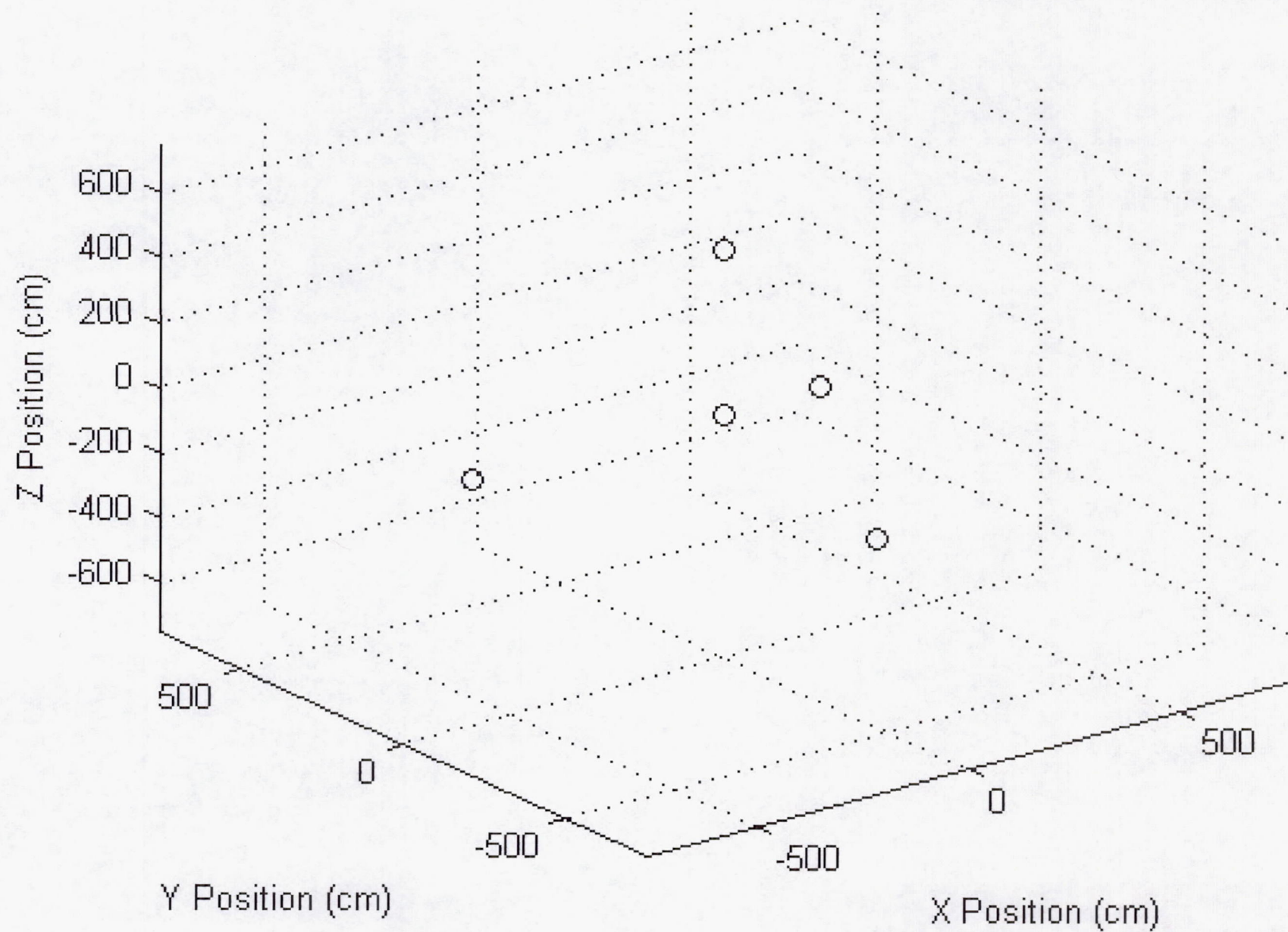



UWB 3D Tracking Simulation (std=0.01)

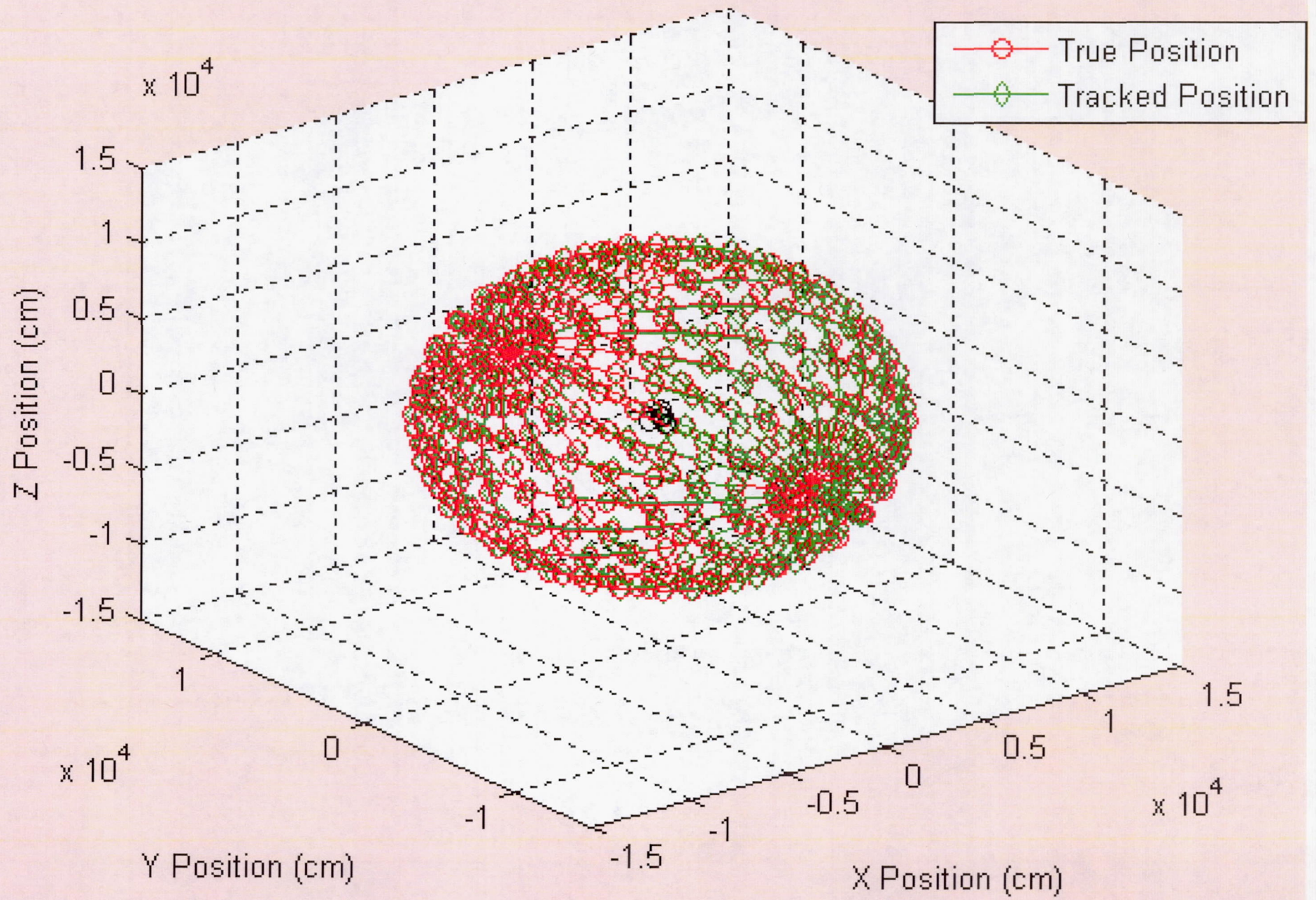

Error Analysis (std=0.01)

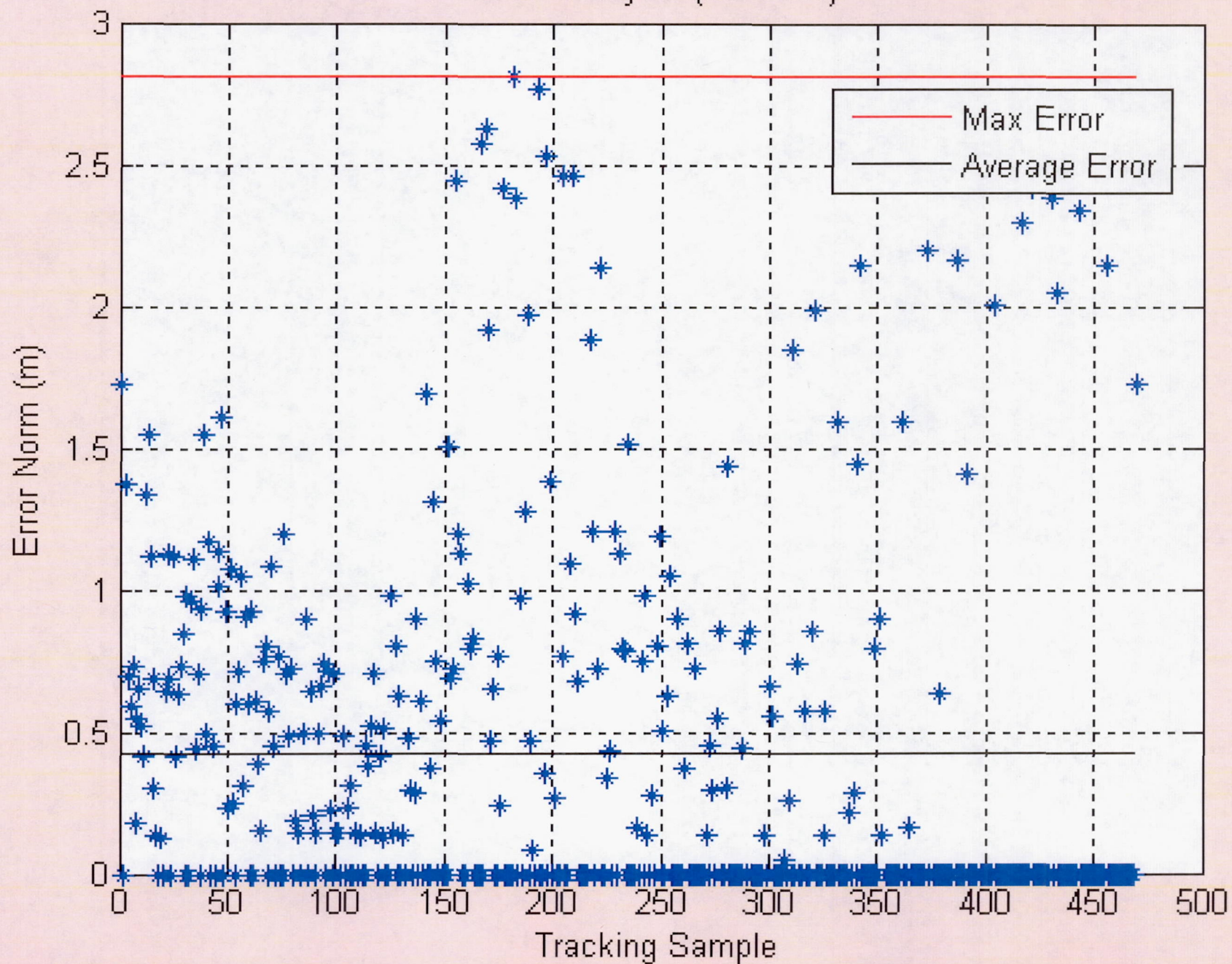

# Lab Experiments ( UWB PulsON 200 Radio)

🔦 Signal Generator



🔦 Evaluation Kit

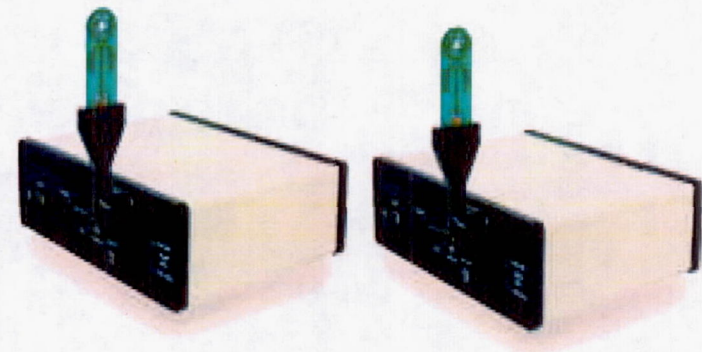

# Lab Experiments (setup)

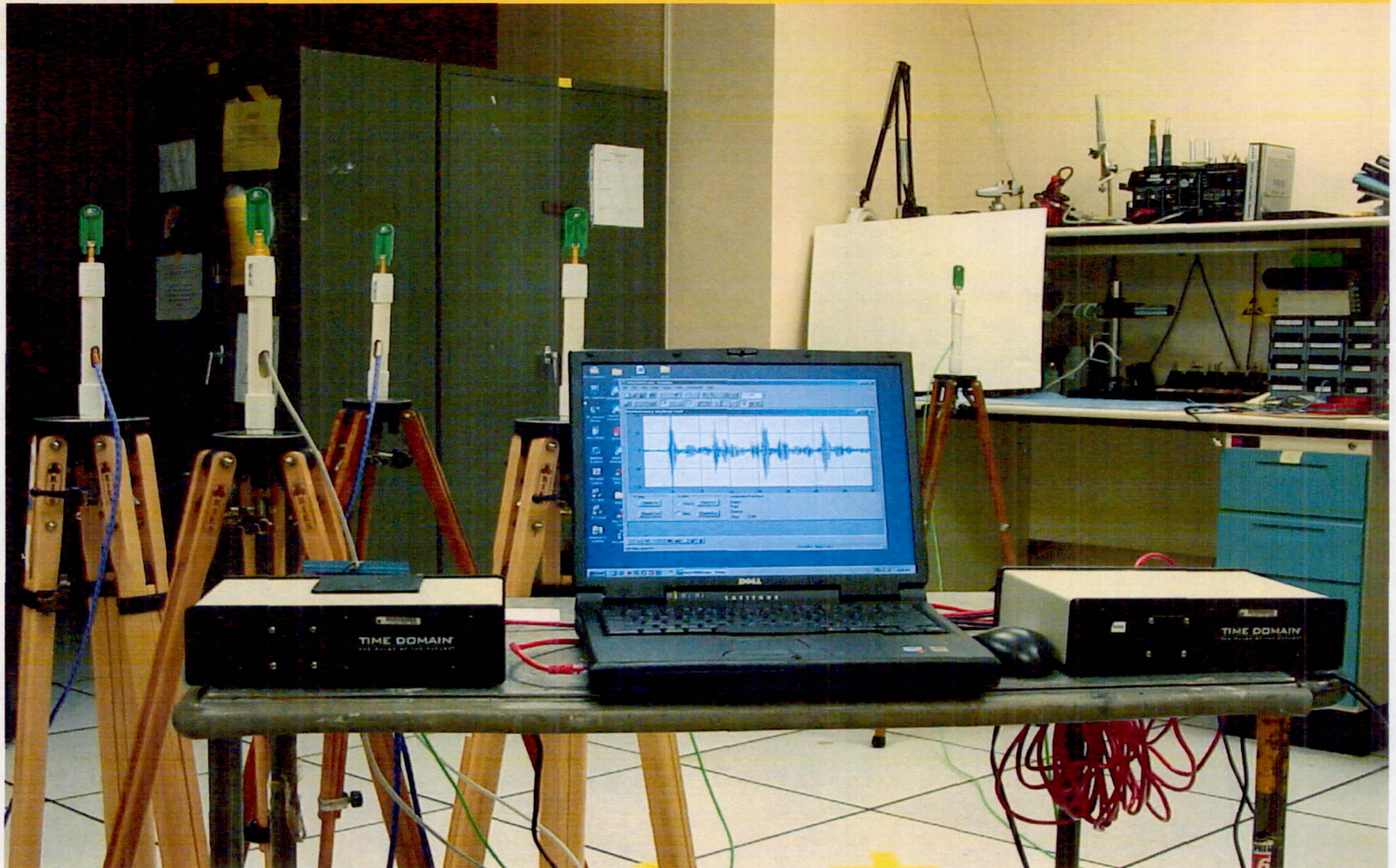

# Lab Experiments ( Four Antenna Scheme)

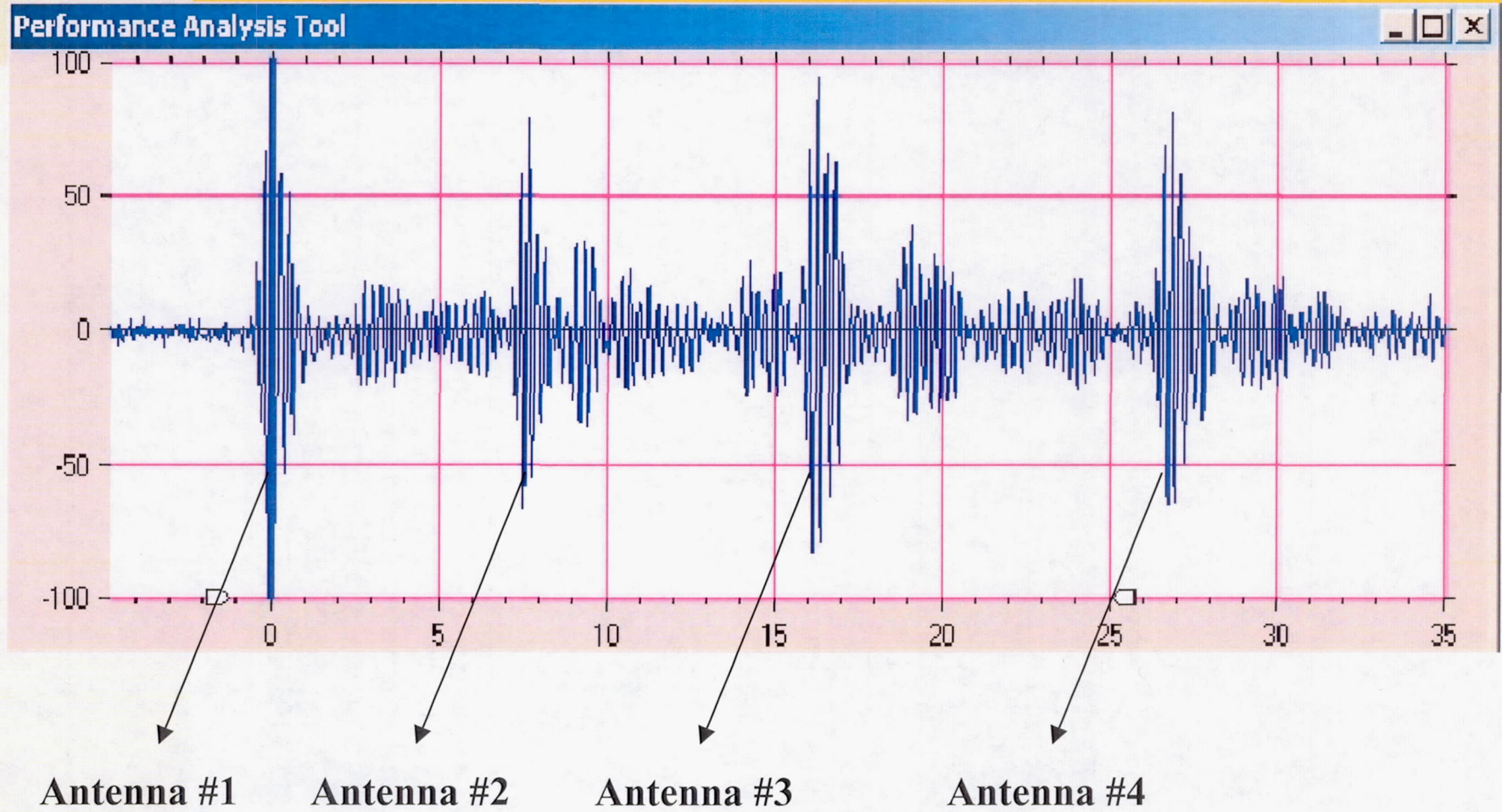



# Lab Test

- ✂ 15 feet by 15 feet lab space
- ✂ 3 antennas mounted evenly on a circle of radius 62cm with the reference antenna at center
- ✂ TDOA data measured from EVK Radios and fed into the tracking algorithm
- ✂ Observed position error (less than 1 foot)

# Error Analysis

$$(x, y) = f(x_i, y_i, \tau_{i1})$$

$$\text{Cov}(x, y) = g(m_\tau, \sigma_\tau^2)$$

$\sigma_\tau^2$  TDOA measurement resolution

$m_\tau$  Receiving antennas configuration



## Conclusion and Future Work

- ✚ A UWB tracking scheme has been established and simulations show TDOA algorithm achieves fine resolution in small error region
- ✚ The preliminary lab experiments demonstrate the tracking capability of the UWB technology
- ✚ Enhanced TDOA estimation method and optimal antenna configuration will be investigated to improve the resolution
- ✚ 2D tracking capability will be extended to 3D



# References

- [1]. Borst,C.W.;et.al.; "Telerobotic ground control of a space free flyer", 1998 IEEE/RSJ International Conference on Intelligent Robots and Systems,vol.2,pp.1183-1189
- [2] Choset,H.;et.al.; "Path planning and control for AERCam, a free-flying inspection robot in space", 1999 IEEE Inter. Conference on Robotics and Automation, ,vol.2,pp.1396-1403
- [3] Kortenkamp,D.;et.al.; "Applying a layered control architecture to a free-flying space camera", 1998 IEEE Inter. Joint Symposia on Intelligence and Systems,pp.188-194
- [4] Loh,Y.C.;et.al.; "Wireless Video System for extra vehicular activity in the International Space Station and Space Shuttle orbiter environment", 1999 IEEE 49th Vehicular Technology Conference, ,vol.2,pp.1203-1206
- [5] FCC First Notice and Order "Revision of Part15 of the Commission's Rules Regarding Ultra-wideband Transmission Systems,"ET-Docket, Feb.2002
- [6]Time Domain Corporation, "PulsON Technology Overview",  
[http://www.timedomain.com/Files/downloads/techpapers/PulsONOverview7\\_01.pdf](http://www.timedomain.com/Files/downloads/techpapers/PulsONOverview7_01.pdf)
- [7] Hussain,M.G.M.; "Principles of space-time array processing for ultrawide band impulse radar and radio communication", IEEE Trans on Vehicular Tech.,vol.51,pp.393-403,May 2002
- [8] Time Domain Corporation, <http://www.timedomain.com/index.cfm>
- [9] XtremeSpectrum,Inc., <http://www.xtremespectrum.com/index.html>
- [10] Adams,J.C.;et.al.; "Ultra-wideband for navigation and communications", Aerospace Conference 2001 IEEE Proceedings,vol.2,pp.2/785-2/792
- [11] Foy,W.H.; "Position-location solutions by Taylor-series estimation", IEEE Transactions on Aerospace and Electronic Systems,vol.AES-12,no.2,pp.187-93,March 1976
- [12] Chan, Y.T.; Ho, K.C.; An efficient closed-form localization solution from time difference of arrival measurements Acoustics, Speech, and Signal Processing, 1994. ICASSP-94., 1994 IEEE International Conference on ,Volume: ii , 19-22 April 1994 Pages:II/393 - II/396 vol.2
- [13] Barton,R.J.;et.al.; "Evaluation of Higher-Order Techniques for Blind Adaptive Channel Estimation on Impulse Radio Channels," submitted to IEEE Transactions on Communications, October 1999,under revision pursuant to review