



The Nutating Engine—Prototype Engine Progress Report and Test Results

Peter L. Meitner

U.S. Army Research Laboratory, Glenn Research Center, Cleveland, Ohio

Mike Boruta and Jack Jerovsek

KINETIC/BEI LLC, South Elgin, Illinois

NASA STI Program . . . in Profile

Since its founding, NASA has been dedicated to the advancement of aeronautics and space science. The NASA Scientific and Technical Information (STI) program plays a key part in helping NASA maintain this important role.

The NASA STI Program operates under the auspices of the Agency Chief Information Officer. It collects, organizes, provides for archiving, and disseminates NASA's STI. The NASA STI program provides access to the NASA Aeronautics and Space Database and its public interface, the NASA Technical Reports Server, thus providing one of the largest collections of aeronautical and space science STI in the world. Results are published in both non-NASA channels and by NASA in the NASA STI Report Series, which includes the following report types:

- **TECHNICAL PUBLICATION.** Reports of completed research or a major significant phase of research that present the results of NASA programs and include extensive data or theoretical analysis. Includes compilations of significant scientific and technical data and information deemed to be of continuing reference value. NASA counterpart of peer-reviewed formal professional papers but has less stringent limitations on manuscript length and extent of graphic presentations.
- **TECHNICAL MEMORANDUM.** Scientific and technical findings that are preliminary or of specialized interest, e.g., quick release reports, working papers, and bibliographies that contain minimal annotation. Does not contain extensive analysis.
- **CONTRACTOR REPORT.** Scientific and technical findings by NASA-sponsored contractors and grantees.

- **CONFERENCE PUBLICATION.** Collected papers from scientific and technical conferences, symposia, seminars, or other meetings sponsored or cosponsored by NASA.
- **SPECIAL PUBLICATION.** Scientific, technical, or historical information from NASA programs, projects, and missions, often concerned with subjects having substantial public interest.
- **TECHNICAL TRANSLATION.** English-language translations of foreign scientific and technical material pertinent to NASA's mission.

Specialized services also include creating custom thesauri, building customized databases, organizing and publishing research results.

For more information about the NASA STI program, see the following:

- Access the NASA STI program home page at <http://www.sti.nasa.gov>
- E-mail your question via the Internet to help@sti.nasa.gov
- Fax your question to the NASA STI Help Desk at 301-621-0134
- Telephone the NASA STI Help Desk at 301-621-0390
- Write to:
NASA STI Help Desk
NASA Center for AeroSpace Information
7121 Standard Drive
Hanover, MD 21076-1320



The Nutating Engine—Prototype Engine Progress Report and Test Results

Peter L. Meitner

U.S. Army Research Laboratory, Glenn Research Center, Cleveland, Ohio

Mike Boruta and Jack Jerovsek

KINETIC/BEI LLC, South Elgin, Illinois

Prepared for
Forum 62
sponsored by the AHS International
Phoenix, Arizona, May 9–11, 2006

National Aeronautics and
Space Administration

Glenn Research Center
Cleveland, Ohio 44135

Acknowledgments

The authors dedicate this paper to the memory of Mr. Len Meyer, the inventor of the Nutating Engine. Regrettably, his untimely death prevented him from seeing his lifelong dream of developing his engine concept come to fruition.

Level of Review: This material has been technically reviewed by technical management.

Available from

NASA Center for Aerospace Information
7121 Standard Drive
Hanover, MD 21076-1320

National Technical Information Service
5285 Port Royal Road
Springfield, VA 22161

Available electronically at <http://gltrs.grc.nasa.gov>

The Nutating Engine—Prototype Engine Progress Report and Test Results

Peter L. Meitner
U.S. Army Research Laboratory
Glenn Research Center
Cleveland, Ohio 44135

Mike Boruta and Jack Jerovsek
KINETIC/BEI LLC.
South Elgin, Illinois 60177

Abstract

A prototype of a new, internal combustion (IC) engine concept has been constructed and initial performance tests have been completed. The Nutating Engine features an internal disk nutating (wobbling) on a Z-shaped power shaft. The engine is exceedingly compact, and several times more power dense than any conventional (reciprocating or rotary) IC engine. This paper discusses lessons learned during the prototype engine's development and provides details of its construction. In addition, results of the initial performance tests of the various components, as well as the complete engine, are summarized.

Introduction

Unmanned Air Vehicles (UAV's), either fixed wing, or VTOL (Vertical Take Off and Landing) have a promising future and figure prominently into the Army's future tactics and operations. However, for small UAV's (arbitrarily defined here as requiring less than approximately 75 kW, or 100 hp), there are no engines available with the following desirable attributes: The ideal engine would simultaneously be fuel efficient, powerful, compact, smooth running (low vibration) and be able to readily burn heavy fuels. The U.S. Army (through a Phase I and Phase II SBIR (Small Business Innovative Research) contract) has sponsored the demonstration of a unique and innovative new engine concept called the Nutating Engine which possesses all these qualities. This paper describes the prototype engine and presents the initial test results.

Engine Concept Description

References 1 through 4 describe various versions of the Nutating Engine and discuss its advantages compared to conventional IC engines (size, power density, and the ability to readily burn heavy fuels). Figure 1 shows the simplest version of the Nutating Engine, which uses a single, two-lobed disk nutating (wobbling) on a Z-shaped power shaft. The unique motion of the disk is achieved by mounting the center of the disk in the middle of the Z-shaft, at an angle to the power shaft. As the power shaft rotates, the disk nutates, but does not rotate with the shaft. This is achieved via an anti-

rotation pin, shown in figure 2. Power is transmitted directly to the output shaft, doing away with the complicated linkages needed in a piston engine to change the linear piston motion to rotating output motion. Since the disk does not rotate, the seal velocities are lower than in an equivalent IC piston engine. The disk wobbles inside a housing and, in its simplest version, half of the single disk (one lobe) performs the intake/compression function, while the other lobe performs the power/exhaust function. Note that the disk lobes can be configured to have equal compression and expansion volumes, or to have the compression volume greater than or less than the expansion volume. This means that the engine can be self-supercharged, or operate as a Miller/Adkinson cycle. Self-supercharging gives better efficiency for high altitude missions, while operating as a Miller cycle gives increased efficiency at low altitude.

The nutating motion of the disk results in each of the displaced volumes being generated twice per engine revolution (via overlapping processes, each over 270° of crank angle), producing two intake/compression and two power/exhaust events per crankshaft revolution. This produces very high power density (2 and 4 times higher than a conventional 2-stroke cycle and 4-stroke cycle engine, respectively) and a smooth torque curve.

The Nutating Engine operates as a four stroke cycle – intake, compression, power (burning) and exhaust. The intake/compression side of the disk feeds the compressed air into an accumulator. From there it is metered to a combustion pre-chamber (at the power/exhaust side of the disk), via valves, which open at the appropriate time (the pre-chamber is that volume into which the fuel and air charge is introduced and contained when the nutating disk is at the position of minimum chamber volume). Fuel is injected, and a spark plug is fired (for a non-compression ignition cycle). The burning gas then expands through the power/exhaust side of the disk. The burning (power producing) process continues over 270° of crank angle (versus 180° for a conventional IC engine). This means that, for heavy fuel, the Nutating Engine can run at higher speeds than a conventional IC engine before the limiting speed (set by the fuel burning rate) is reached. This further increases power density. Also, the geometric shape of the combustion volume always has a three-dimensional character, which aids the combustion process.

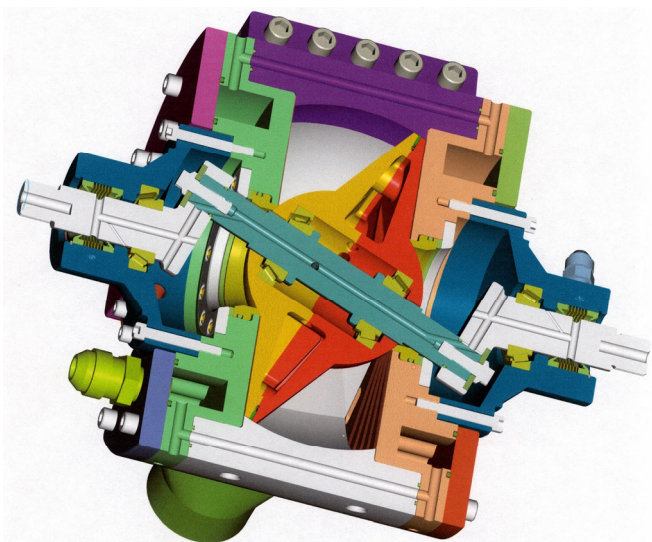

Figure 1.—Single-disk nutating engine cross section.

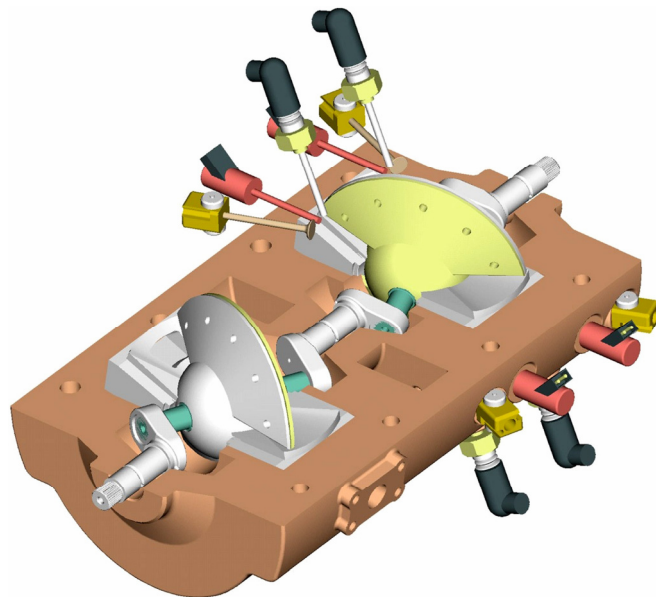

Figure 3.—Two-disk prototype nutating engine cut-away.

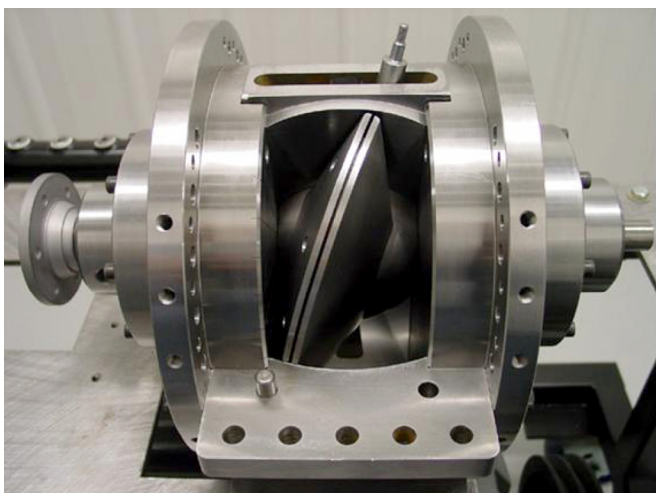

Figure 2.—Single-disk nutating engine engine with outer shroud removed, showing anti-rotation pin.

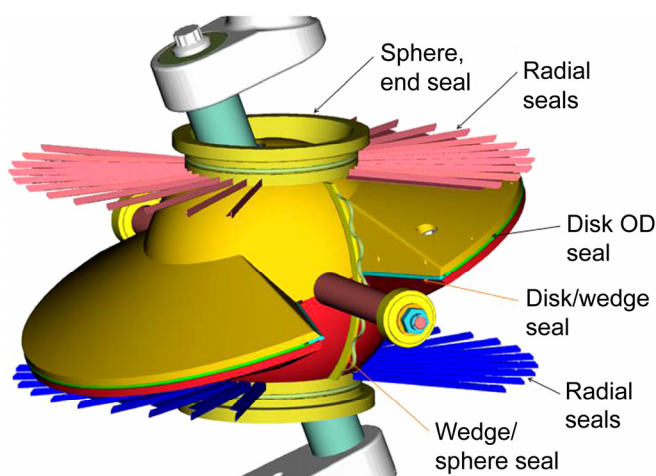
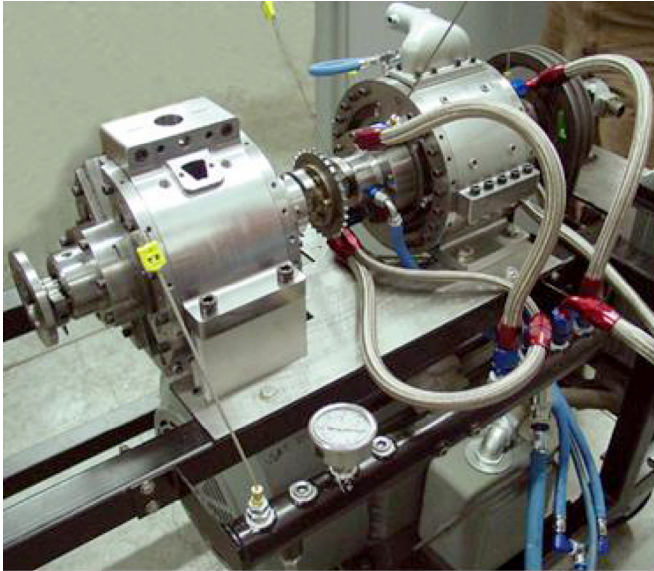

Figure 4.—Nutating engine seal configurations.

Prototype Engine Description

To simplify the prototype engine construction and to help in the understanding of the individual processes, the prototype Nutating Engine was constructed using two disks, one disk dedicated solely to the intake/compression function, and the other to the power/exhaust function (fig. 3). In addition, the significant time and money constraints inherent in a Phase II SBIR contract dictated a spark ignited (versus compression ignited), relatively low compression ratio (10:1) configuration, with initial testing performed with gasoline instead of heavy fuel. For the prototype engine, the most important contribution was felt to be the successful demonstration of the basic cycle, which could most readily be demonstrated with gasoline. The more challenging issue of operating on heavy fuel (and at pressure ratios allowing compression ignition) will be addressed in future efforts.

The development of the Nutating Engine necessitated a multi-pronged approach. A modeling and simulation effort developed computer programs to better understand the complex geometric, kinematic, combustion, and thermodynamic aspects of this unique engine configuration. Additional, difficult factors which had to be addressed included the development of seals, a combustion pre-chamber, oil circuits, cooling circuits, controls, and a fuel injection system. Paper length limitations preclude a discussion of all these items, but the final prototype engine seal configurations are shown in figure 4. The radial seals shown in figure 4 are located on the insides of the housing side walls, placed every 10° along the path of the disk. During its motion, the disk moves over and depresses the seals in an almost pure rolling motion (there is some sliding). Note that the outer surfaces of the disks never come in contact with the housing inner walls.



Prototype nutating engine characteristics:

Horsepower to displacement	0.461 hp/in. ³
Number of disks	2
Disk diameter	8 in.
Compression ratio	10:1
Disk phasing	180°
Nutating angle	± 20°
Max engine speed	3000 rpm
Total chamber displacement	29 in. ³
Total engine displacement	232 in. ³
Brake hp (BHP) at 3000 rpm	107 hp
Torque (ft-lb)	187 ft-lb
Weight	145 lb

Figure 5.—Prototype nutating engine and characteristics.

This gives the Nutating Engine a distinct advantage over all other IC engines, since it allows the majority of the housing inner wall surfaces and the power/exhaust disk outer surfaces (except for the areas holding or making contact with the seals) to be thermal barrier coated. This, in turn, greatly reduces the heat soaking into the engine, allowing a much smaller cooling system, as well as increasing engine performance. This feature was not incorporated into the prototype engine.

Figure 5 shows the completed Prototype Nutating Engine, along with geometric characteristics and predicted performance parameters. Note that over 100 hp are expected to be produced at 3000 rpm from 2 disks only 8 in. (20.32 cm) in diameter. The prototype engine was constructed from steel, without regard to low weight, and a fully developed engine would be far lighter than the prototype's 148 lb (67.3 kg). For comparison, figure 6 shows projections for a fully developed UAV engine using two 5 in. (12.7 cm) diameter disks. This engine measures a very compact 16 in (41 cm) long, 9 in. (23 cm) high, and 7.5 in. (19 cm) wide, and is conservatively predicted to produce 50 hp at 5000 rpm and to weigh only 32.5 lb (14.77 kg). No other IC engine available today can approach these numbers.

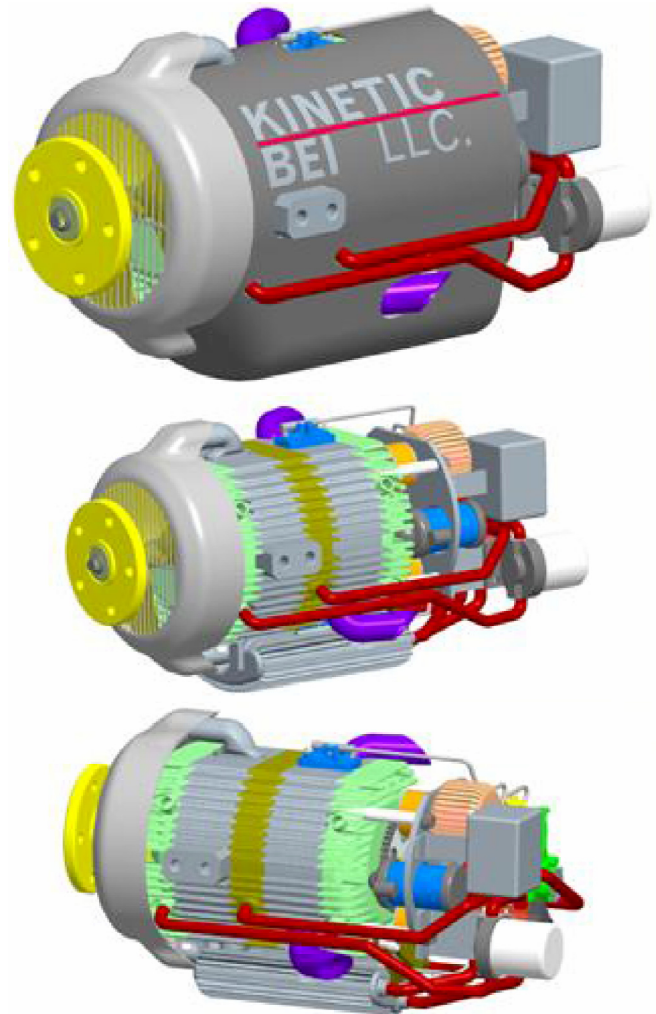

Next generation concept for UAV applications:

Number of disks	2
Disk diameter	5 in.
Nutating angle	± 20°
Engine operating speed	5000 rpm
Total engine displacement	57 in. ³
Brake hp (BHP) at 5000 rpm	50 hp
Weight	32.5 lb
Single cooling media	
Aluminum alloy construction	
Engine size; 16 in. long × 9 in. high × 7.5 in. wide	
Heavy fuel operation by in.	

Figure 6.—Nutating engine for UAV applications.

Test Results

Intake/Compression Module

As already stated, for cost and risk reduction purposes, the intake/compression disk was designed for a compression ratio of only 10:1 (necessitating spark ignition). During testing, the disk was driven by an electric motor and the resulting flows, temperatures, and pressures were measured. Tests were first

conducted with open outlet ports and then with the outlet ports plumbed into an accumulator which was manually throttled to maintain a desired accumulator pressure. The intake/compression module (disk) performed as intended, achieving the design pressure ratio “out of the box.” With the accumulator outlet valve closed (dead headed flow), the disk provided pressures well above the design pressure ratio. Compression efficiency was very good and increased with time, presumably caused by “seating” of the seals. Maximum test speed was 2600 rpm. These excellent results strongly suggest that future designs will readily achieve the higher pressure ratios needed for compression ignition.

Power/Exhaust Module

To reduce wear and tear on the intake/compression disk, the power/exhaust disk was first tested as a stand-alone unit by connecting it to a high pressure air tank. This caused the disk to rotate and to produce measurable power (with no combustion taking place). Once a steady rpm was established, fuel was briefly injected and the spark plugs were fired, resulting in increased rpm and exhaust temperature. These tests began to establish an understanding of the important and complex relationships between air flow, pre-chamber geometry, and fuel injection and spark timing. High speed samples of chamber pressure were taken for every degree of module crank angle.

Complete Engine

Once the basic operation of the Power/Exhaust module had been verified by the described stand-alone tests, the Intake/Compression and Power/Exhaust modules were connected and briefly tested as a complete engine.

Unfortunately, by this time, the allocated resources of the Phase II SBIR contract had been depleted. Limited testing verified that the engine self-sustained, but no performance data were taken.

Conclusions

- 1) The primary goal of the Army’s Phase II SBIR contract has been met successfully. The Nutating Engine concept’s mechanical integrity has been demonstrated and its thermodynamic cycle has been validated.
- 2) Compressor performance exceeded expectations, with the critical components showing little or no wear.

- 3) The Expander worked well, and also exhibited low friction.
- 4) As with any new engine, the major challenge is the combustion system and its optimization. The complex relationships between air flow, combustion pre-chamber geometry, fuel injection and spark timing are, as yet, not sufficiently understood.
- 5) While harsh programmatic time and cost constraints have limited the scope of the prototype engine testing, the authors are confident that further development of this unique engine cycle will produce a heavy fuel engine that is unrivaled in regards to compactness and high power density for a multitude of applications.

References

1. Meitner, P., and Boruta, M., “The Nutating Engine –The Ideal, Heavy-Fuel Powerplant for Small UAV’s,” American Helicopter Society 59th Forum Proceedings, Phoenix, AZ, May 2003.
2. Korakianitis, T., Meyer, L., Boruta, M., and McCormick, H., “Introduction and Performance Prediction of a Nutating-Disk Engine,” ASME 99–GT–279, International Gas Turbine & Aeroengine Congress & Exhibition, Indianapolis, IN, June 1999.
3. Korakianitis, T., Meyer, L., Boruta, M., and McCormick, H., “One-Disk Nutating-Engine Performance for Unmanned Aerial Vehicles,” ASME 2001–GT–466, International Gas Turbine & Aeroengine Congress & Exhibition, New Orleans, LA, June 2001.
4. Korakianitis, T., Meyer, L., Boruta, M., and McCormick, H., “Alternative Multi-Nutating-Disk Engine Configurations for Diverse Applications,” ASME 2001–GT–572, International Gas Turbine & Aeroengine Congress & Exhibition, New Orleans, LA, June 2001.

REPORT DOCUMENTATION PAGE

Form Approved
OMB No. 0704-0188

Public reporting burden for this collection of information is estimated to average 1 hour per response, including the time for reviewing instructions, searching existing data sources, gathering and maintaining the data needed, and completing and reviewing the collection of information. Send comments regarding this burden estimate or any other aspect of this collection of information, including suggestions for reducing this burden, to Washington Headquarters Services, Directorate for Information Operations and Reports, 1215 Jefferson Davis Highway, Suite 1204, Arlington, VA 22202-4302, and to the Office of Management and Budget, Paperwork Reduction Project (0704-0188), Washington, DC 20503.

1. AGENCY USE ONLY (<i>Leave blank</i>)	2. REPORT DATE October 2006	3. REPORT TYPE AND DATES COVERED Technical Memorandum	
4. TITLE AND SUBTITLE The Nutating Engine—Prototype Engine Progress Report and Test Results		5. FUNDING NUMBERS WBS 22R-714-30-0359-02	
6. AUTHOR(S) Peter L. Meitner, Mike Boruta, and Jack Jerovsek			
7. PERFORMING ORGANIZATION NAME(S) AND ADDRESS(ES) National Aeronautics and Space Administration John H. Glenn Research Center at Lewis Field Cleveland, Ohio 44135-3191		8. PERFORMING ORGANIZATION REPORT NUMBER E-15562	
9. SPONSORING/MONITORING AGENCY NAME(S) AND ADDRESS(ES) National Aeronautics and Space Administration Washington, DC 20546-0001 and U.S. Army Research Laboratory Adelphi, Maryland 20783-1145		10. SPONSORING/MONITORING AGENCY REPORT NUMBER NASA TM-2006-214342 ARL-MR-0641	
11. SUPPLEMENTARY NOTES Prepared for Forum 62 sponsored by AHS International, Phoenix, Arizona, May 9-11, 2006. Peter L. Meitner, e-mail: p.l.meitner@nasa.gov, U.S. Army Research Laboratory, NASA Glenn Research Center; Mike Boruta, e-mail: kineticresearch@sbcglobal.net, and Jack Jerovsek, e-mail: bakereng@pathwaynet.com, KINETIC/BEI LLC, 2197 Brookwood Dr., South Elgin, Illinois, 60177. Responsible person, Peter L. Meitner, organization code Z, 216-433-3715.			
12a. DISTRIBUTION/AVAILABILITY STATEMENT Unclassified - Unlimited Subject Category: 07 Available electronically at http://gltrs.grc.nasa.gov This publication is available from the NASA Center for AeroSpace Information, 301-621-0390.		12b. DISTRIBUTION CODE	
13. ABSTRACT (<i>Maximum 200 words</i>) A prototype of a new, internal combustion (IC) engine concept has been completed. The Nutating Engine features an internal disk nutating (wobbling) on a Z-shaped power shaft. The engine is exceedingly compact, and several times more power dense than any conventional (reciprocating or rotary) IC engine. This paper discusses lessons learned during the prototype engine's development and provides details of its construction. In addition, results of the initial performance tests of the various components, as well as the complete engine, are summarized.			
14. SUBJECT TERMS Internal combustion engines; Compression ratio; Efficiency		15. NUMBER OF PAGES 10	16. PRICE CODE
17. SECURITY CLASSIFICATION OF REPORT Unclassified	18. SECURITY CLASSIFICATION OF THIS PAGE Unclassified	19. SECURITY CLASSIFICATION OF ABSTRACT Unclassified	20. LIMITATION OF ABSTRACT

