

Source Noise Modeling Efforts for Fan Noise in NASA Research Programs

**Dennis L. Huff
NASA Glenn Research Center
Cleveland, Ohio**

ABSTRACT

There has been considerable progress made in fan noise prediction over the past 15 years. NASA has conducted and sponsored research that has improved both tone and broadband fan noise prediction methods. This presentation highlights progress in these areas with emphasis on rotor/stator interaction noise sources. Tone noise predictions are presented for an advanced prediction code called "LINFLUX". Comparisons with data are included for individual fan duct modes. There has also been considerable work developing new fan broadband noise prediction codes and validation data from wind tunnel model tests. Results from several code validation exercises are presented that show improvement of predicted sound power levels. A summary is included with recommendations for future work.

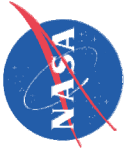

Source Noise Modeling Efforts for Fan Noise in NASA Research Programs

Presented to
2006 Honeywell Acoustics Symposium
October 18, 2006

Dennis Huff
Chief, Acoustics Branch
NASA Glenn Research Center

Special thanks to Dr. Edmane Envia for help with presentation material

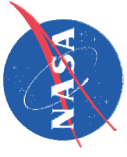

Turbofan Noise Sources

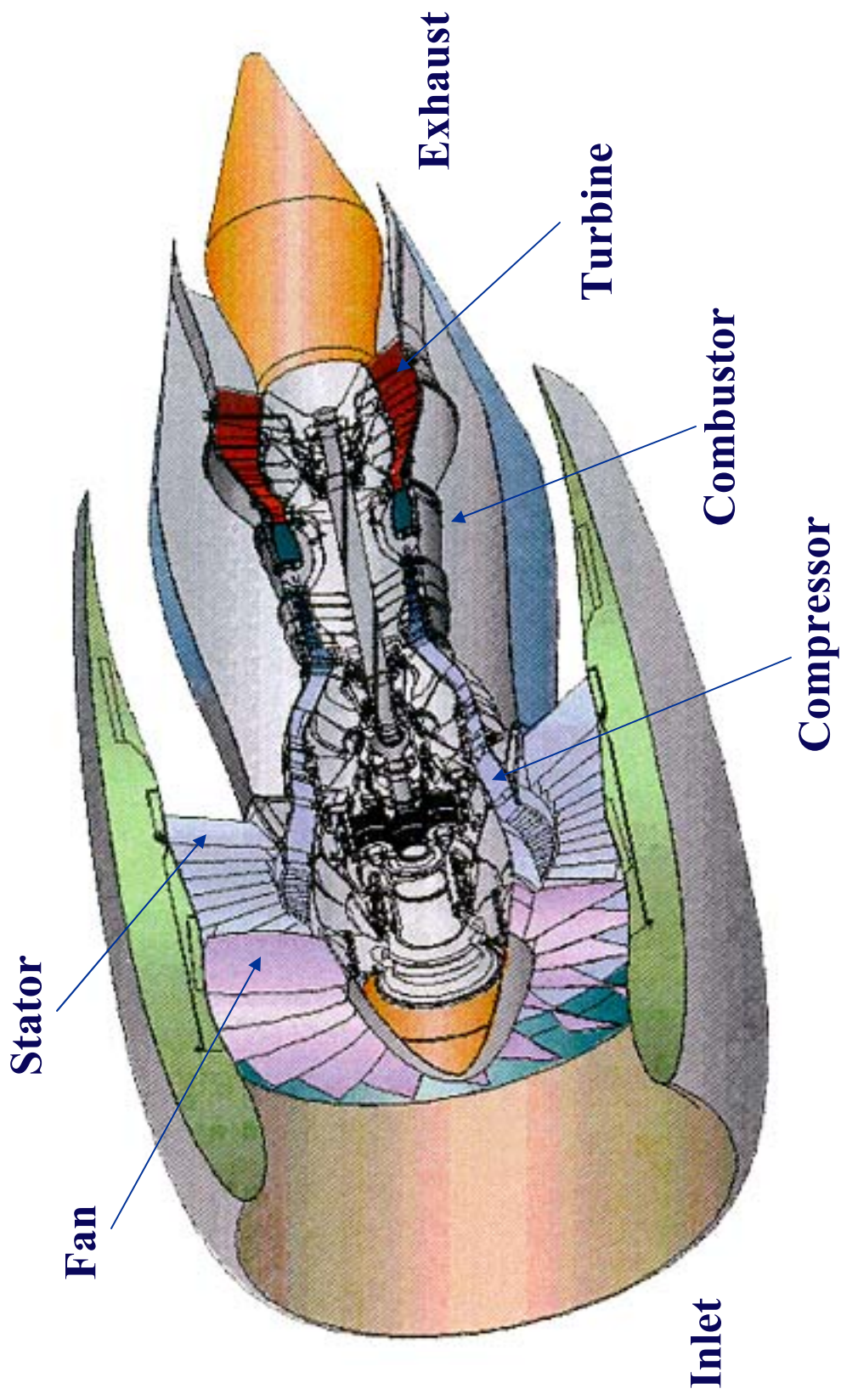

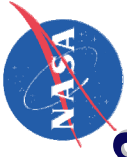

Rotor/Stator (R/S) Interaction Noise Prediction

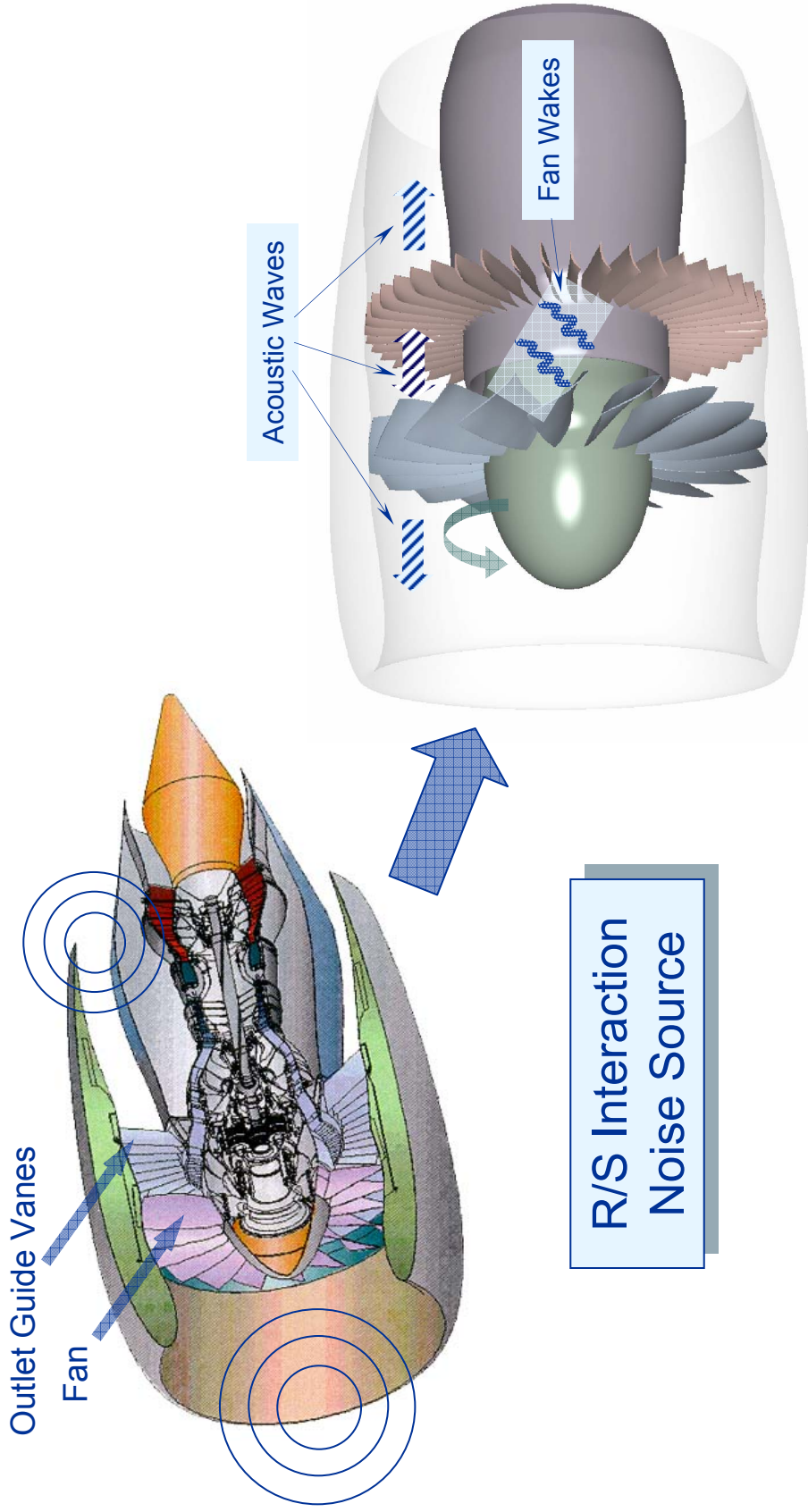

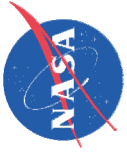

Modeling Strategy

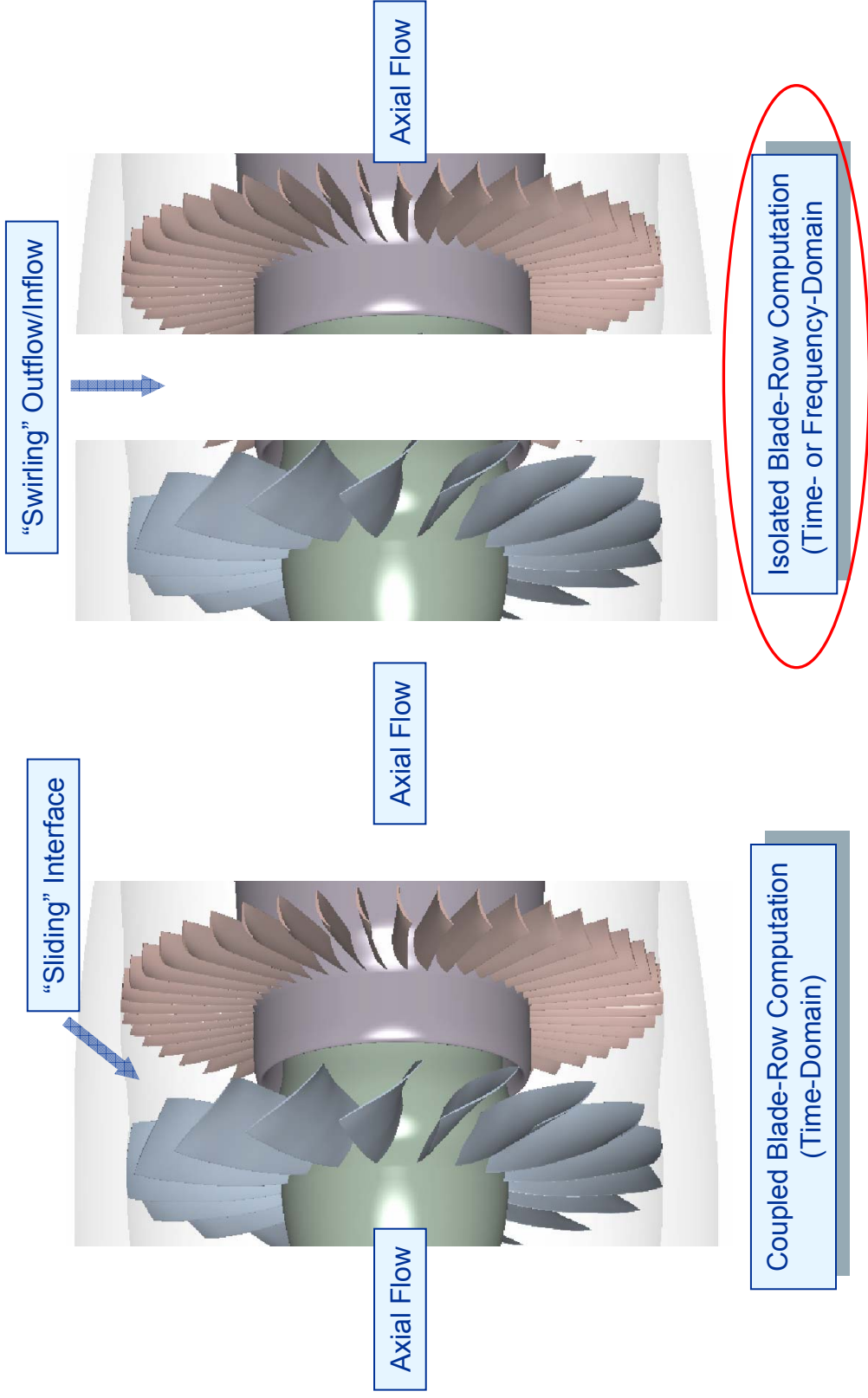

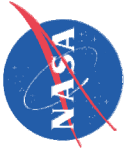

Tone Noise Prediction

< 1992

- Empirical methods by Heidmann, included in ANOPP
- “BBN” or “V072” Code (Bolt Beranek and Newman)
- Single blade row source model, blade row transmission models
- Duct sound power predictions, normalized inlet directivity (Eversman)

1992 - 2000

- Updates to ANOPP using newer engine/fan data
- “TFANS” and “LINFUX” Codes (United Technologies)
- Coupled Blade Rows with Inlet/Aft Radiation
- Far field sound pressure levels and directivity (Eversman, RDIFF)
- Multiple Pure Tone (MPT) prediction (General Electric, Honeywell)

2000 - present

- Engine validation (includes several Honeywell engines)
- “BASS” Code (University of Toledo/NASA)
- Begin integrating tone and broadband prediction methods
- Far field directivity (CDUCT, BIEM)

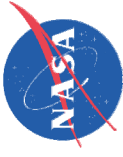

Frequency-Domain: LINFLUX Code

□ Approach

- Fan Wake Description: Steady RANS
 - **Extract wake harmonic content at OGV leading edge**
- OGV Acoustic Response: Linearized Unsteady Euler
 - **TURBO (inviscid steady mean flow)**
 - **LINFLUX* (unsteady perturbations, acoustics)**

* Verdon et al. (see NASA/CR-2001-210713)

□ Technical Challenges

- Turbulence Model, Realistic Wake Diffusion (Grid Orientation)
- Non-Reflecting Boundary Conditions for Non-uniform Inflow/Outflow
- Stringent Computational Accuracy Requirements†

† Acoustic Pressure Perturbations ~0.2% of Background Flow (140 dB = 0.03 psi)

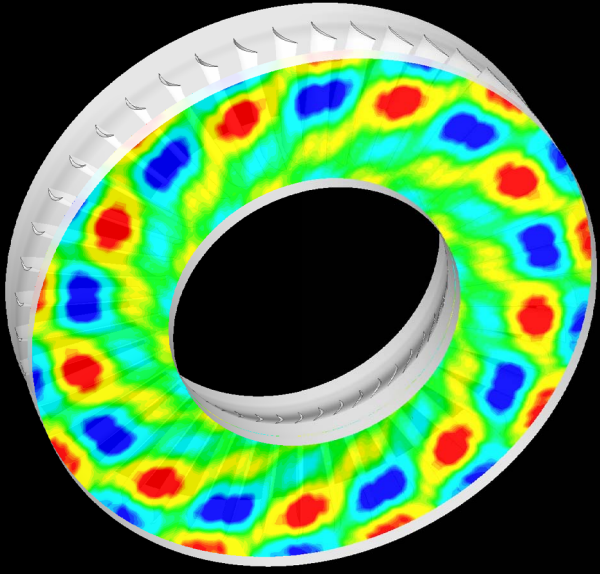

... radiate forward

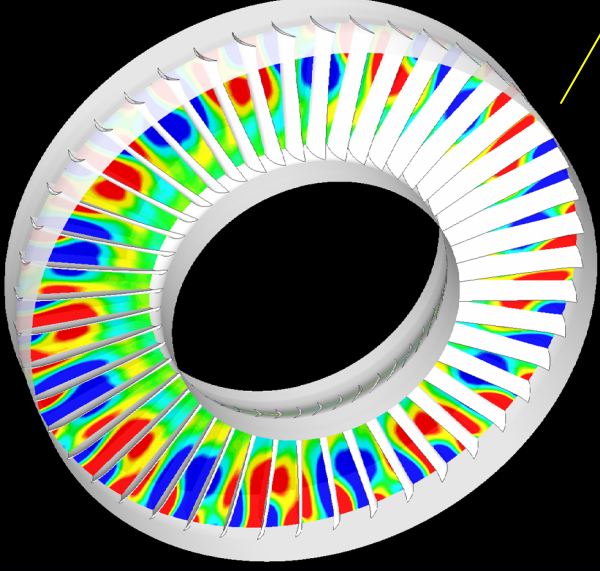

Acoustic Waves
Generated at the stator ...

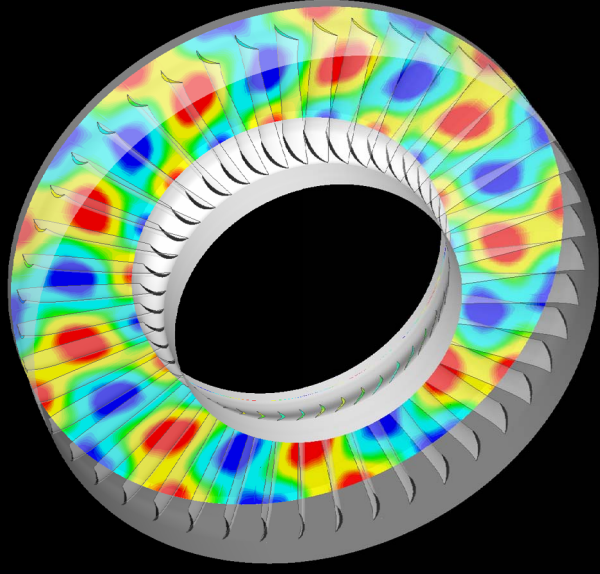

... radiate aft

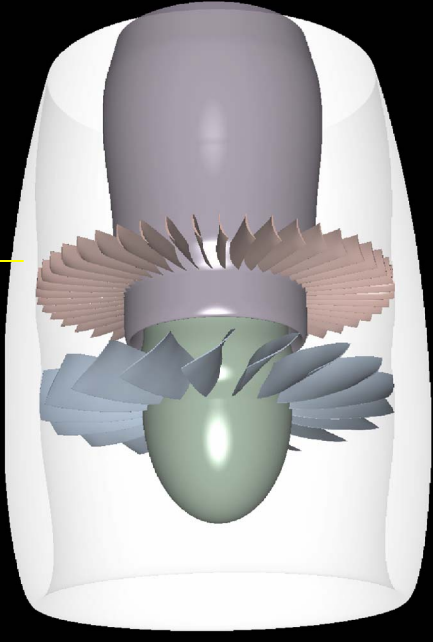

Computational AeroAcoustics (CAA)

Simultaneous prediction of flow field and both near- and far-field sound of realistic geometries.

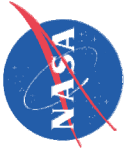

Validation (An Example)

- Validation: Source Diagnostic Test (SDT) Fan
 - 22 Blades, 54/26 Vanes
 - Design Tip Speed ~ 1200 fps
 - Comparison for 1x and 2xBPF Tone Levels at 62% Design Tip Speed



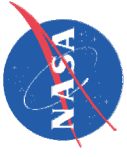

Data-Theory Comparisons

Cut-Off Stator (54-Vanes)

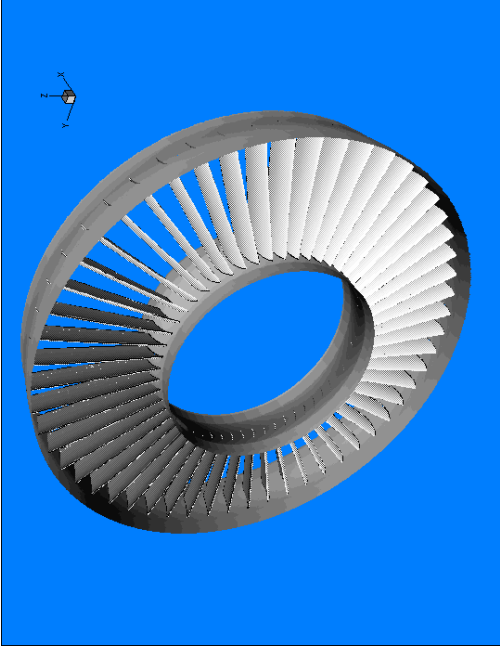

Cut-On Stator (26-Vanes)

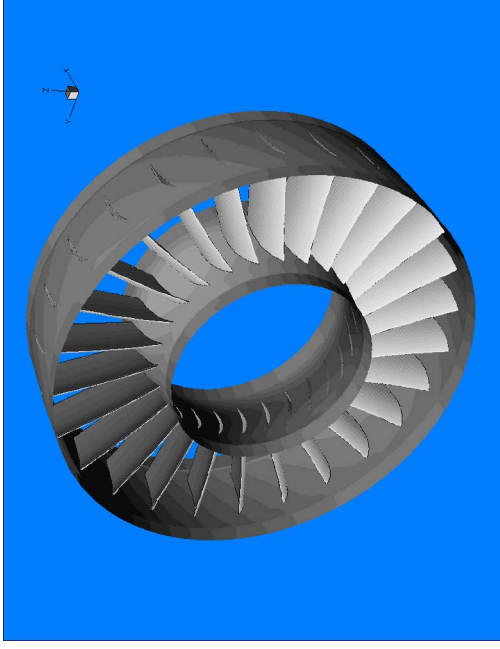

Downstream Tone Levels: Prediction **Data**

Cut-Off Stator (2xBPF)		Cut-On Stator (1xBPF)	
Mode: (m,n)	Power (dB)	Mode: (m,n)	Power (dB)
(-10,0)	113 111	(-4,0)	124 124
(-10,1)	100 97	(-4,1)	120 120
(-10,2)	101 103		
(-10,3)	102 98		
Total	114 112	Total	125 125

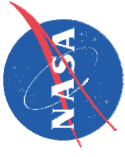

Other Predictions

54-Vane Configuration: Leaned OGV (Composite)

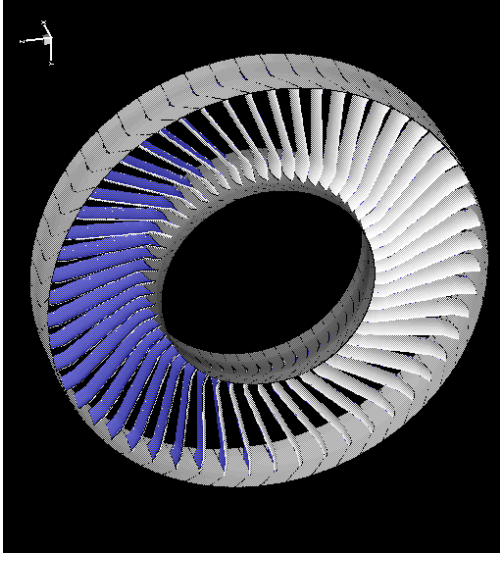
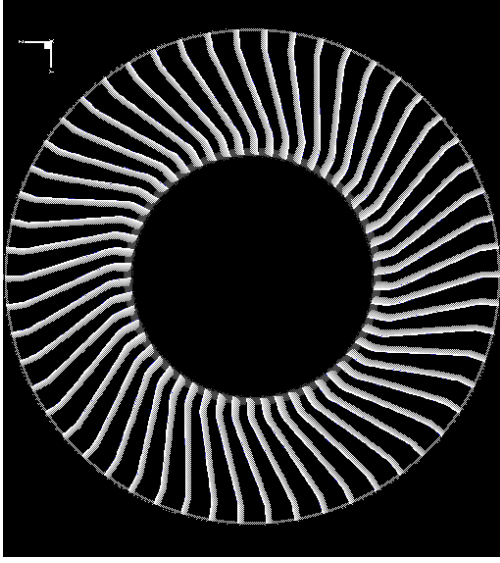

□ Summary

- 6 dB noise reduction benefits predicted at 2xBPF (compared with radial OGV)
- V072 predicts 8 dB power level reduction for this configuration

m,n	SPL	Power
(-10,0)	118 111	112 105
(-10,1)	106 105	100 98
Total	118 112	112 106

Radial OGV (Prediction)
Composite Lean (Prediction)

6 dB Reduction Predicted

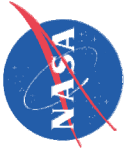

Time-Domain: BASS Code

Goal: Develop a 3D time-accurate nonlinear fan noise prediction code.

Status: The development of the 3D code is completed and the code is being exercised for the SDT stator problem.

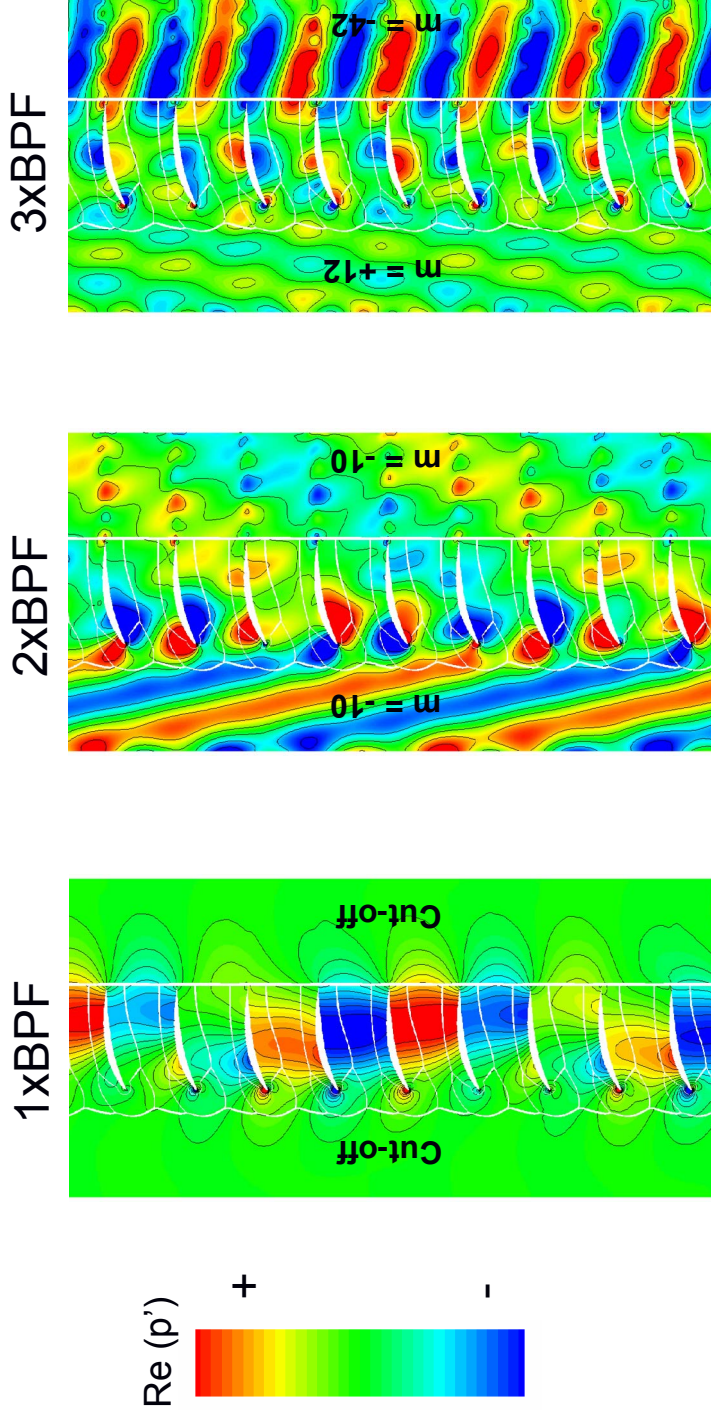

2D Benchmark Problem

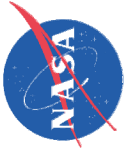

2D Comparisons

- Benchmark comparisons for a 2D cascade problem show good agreement with results from LINFLUX and other codes.

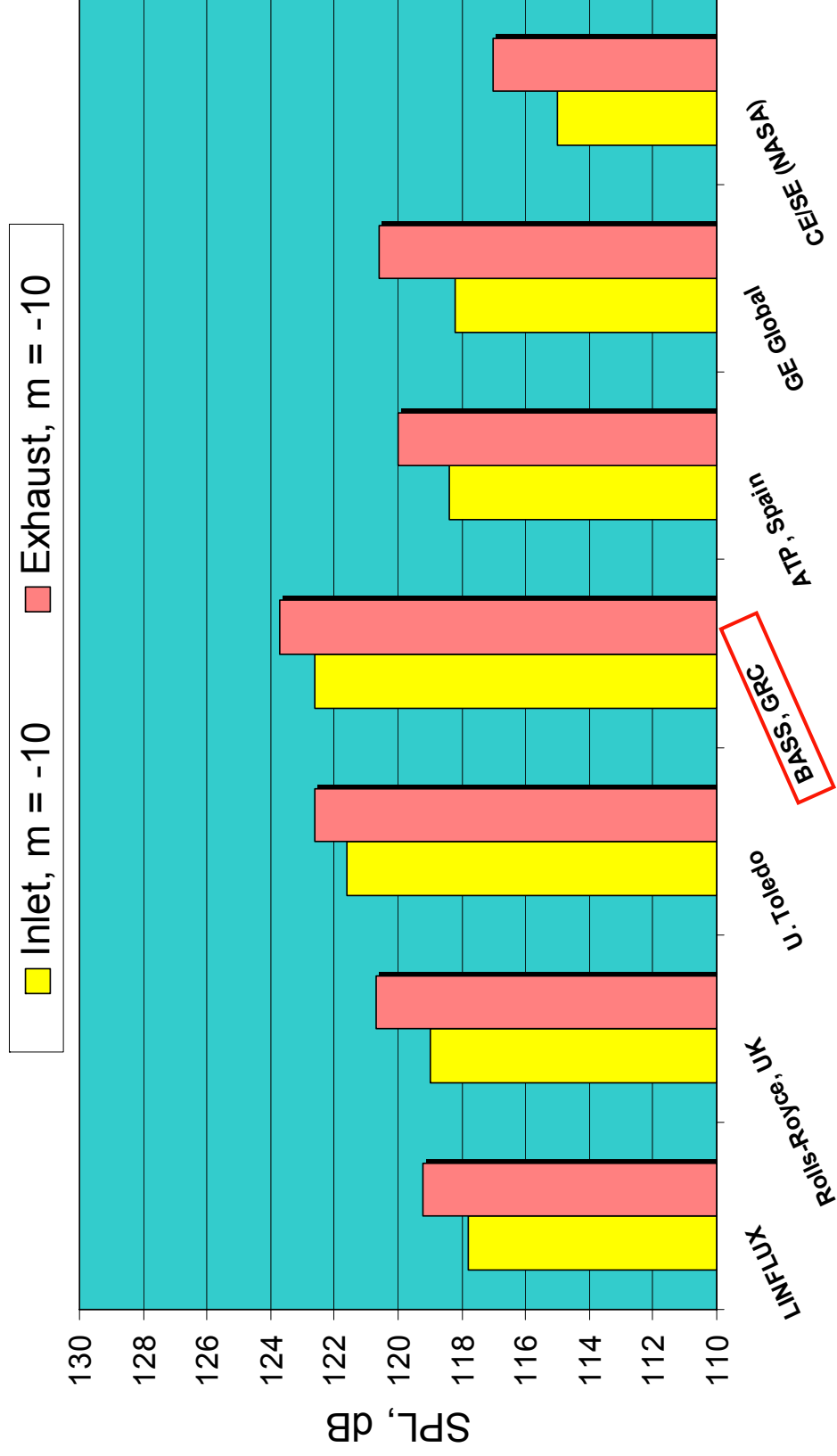

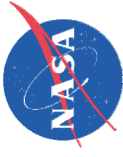

Broadband Noise Prediction

< 1992

- Empirical methods by Heidmann, included in ANOPP
- “BBN” Code (developed, but not exercised for broadband noise)
- Single blade row source model
- Duct sound power predictions, no directivity

1992 - 2000

- Updates to ANOPP using newer engine/fan data
- Mani (GE), BBN (NASA) and Glegg/BFANS (FAU, P&W) Codes
- Duct sound power predictions
- Directivity predicted using Rice methods (equal energy per mode)
- Concerted effort to develop comprehensive data bases (Boeing, NASA)

2000 - present

- Source Diagnostics Tests – unsteady surface pressures, LDV, acoustics
- “BASS” Code
- Emphasis on developing time-dependant measurement methods (PIV)
- Working toward unified prediction methods

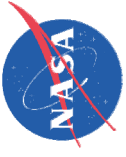

Boeing 18-Inch Fan Rig Test Results (1995)

Components of Fan Broadband Noise

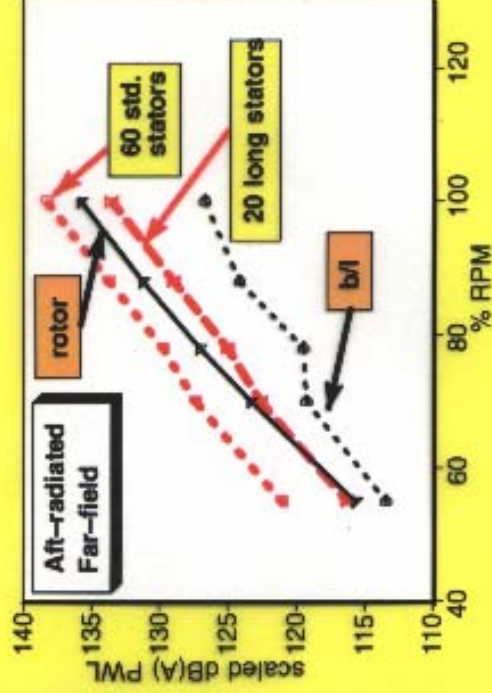
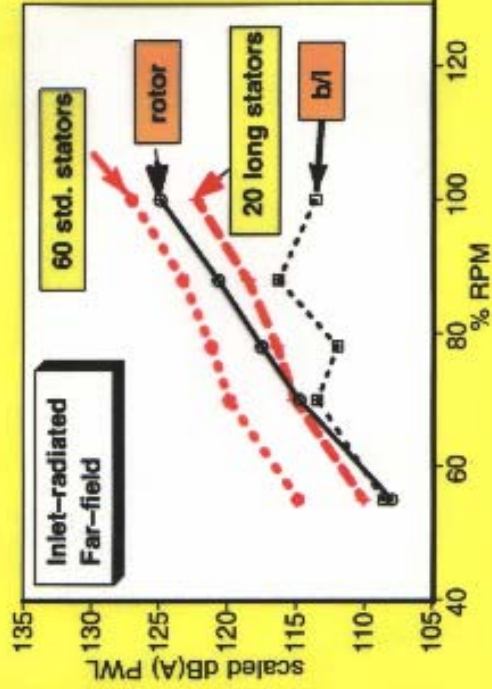

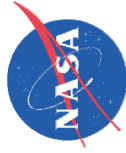

1995 State of the Art

- 5 to 35 dB difference between prediction and data
- Trends not predicted well (rotor-alone vs. with stators)

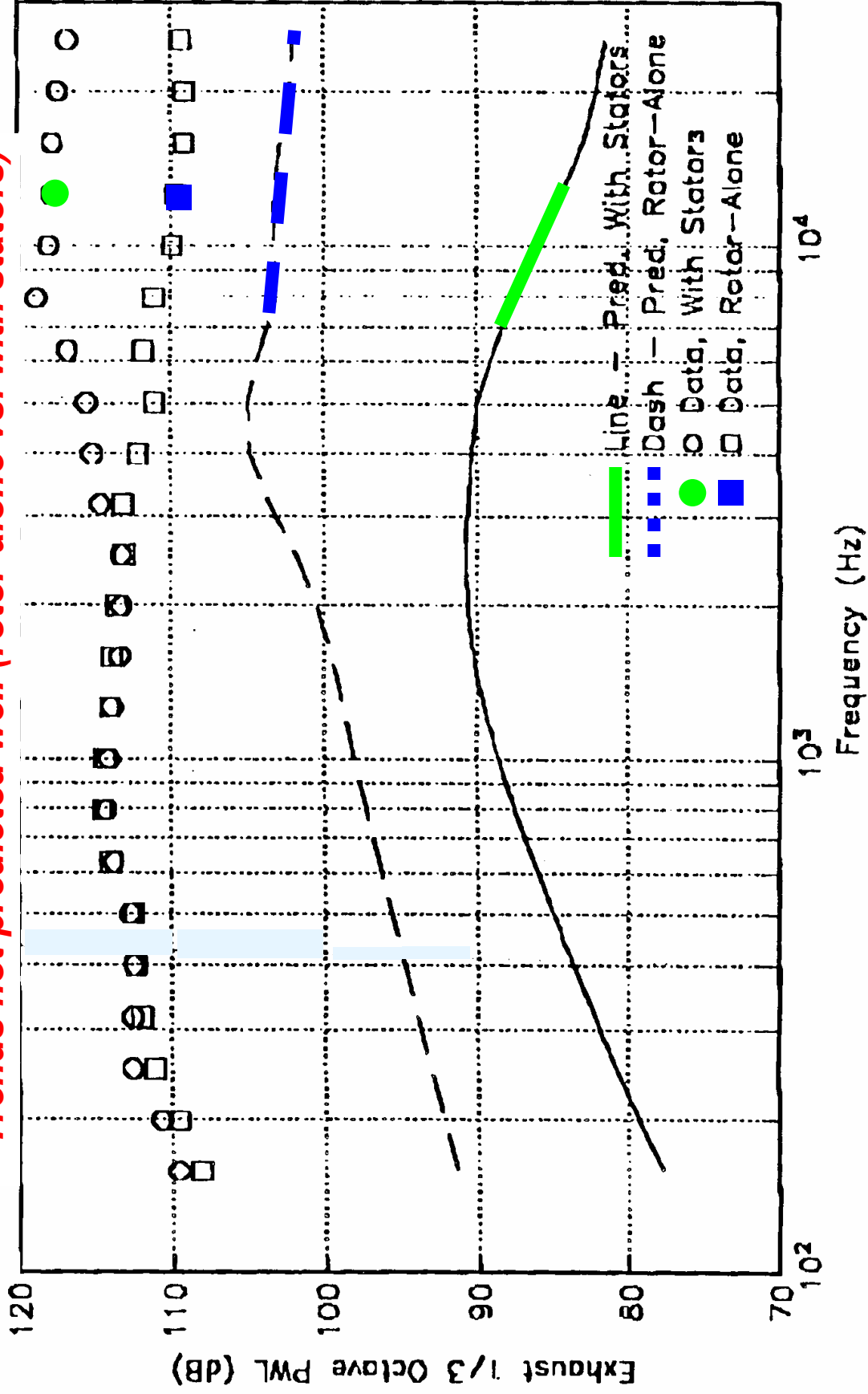

Ref: Mani, R., Gliebe, P.R., and Ho, P.Y.: "Fan Broadband Noise Model Development"
 NASA CR 198457, December 1997.

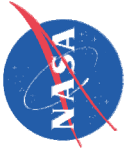

Frequency-Domain: BBN Code

□ Methodology

- (1) Wake Description: RANS Calculations
 - Meanflow characteristics
 - Turbulence intensity and integral length scales
- (2) Blade-Row Response: Isolated Flat-Plate Annular Cascade
 - Stripwise lift response (2D cascade)
 - Classical duct acoustics (3D)
- (3) Broadband Spectrum: Combine (1) & (2)
 - Modal power description on per frequency basis
 - “Inlet” and “exhaust” spectra of in-duct acoustic power

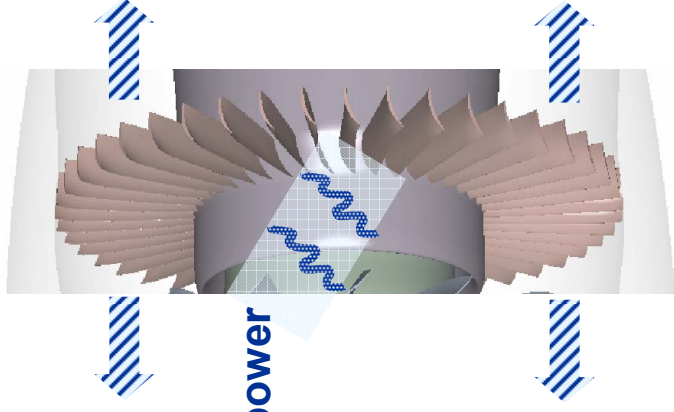

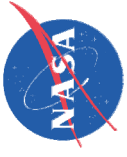

Input to the BBN Code

□ RANS Results (example)

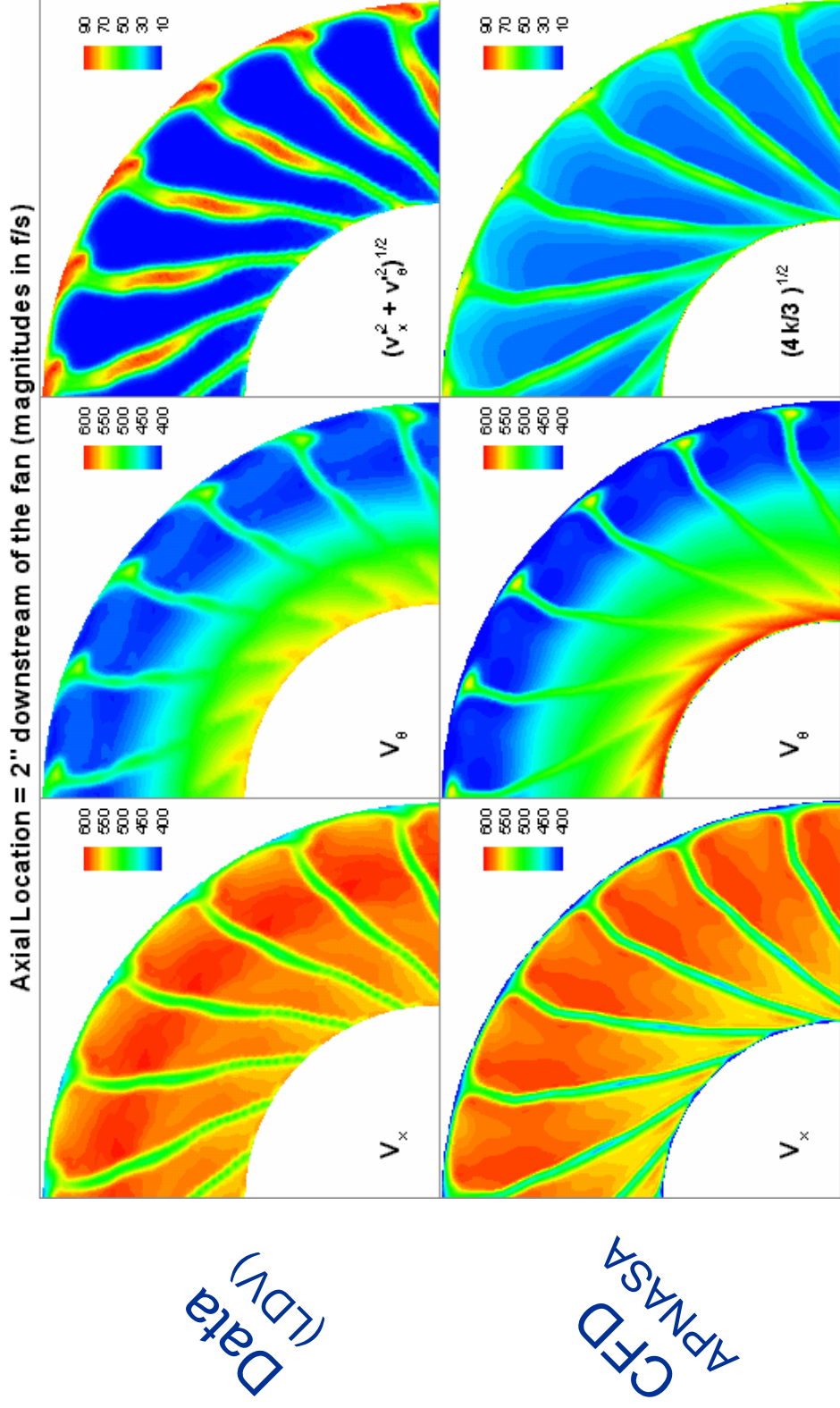

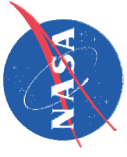

Input to the BBN Code

Wake Turbulence Model

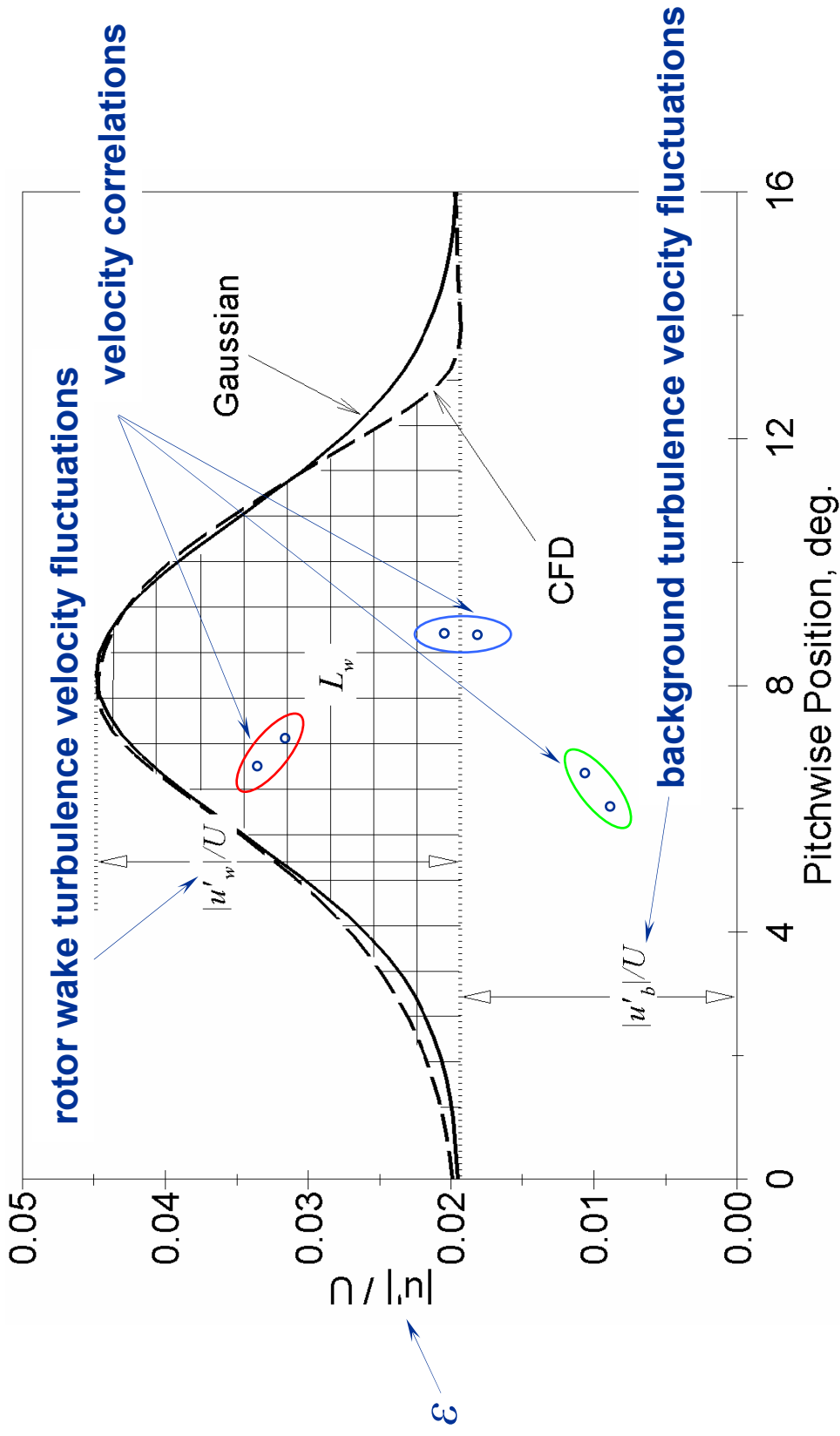

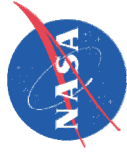

Validation (An Example)

□ Testbed: 22-inch Source Diagnostic Test Fan Rig



SDT Fan Rig: Design Tip Speed = 1200 fps

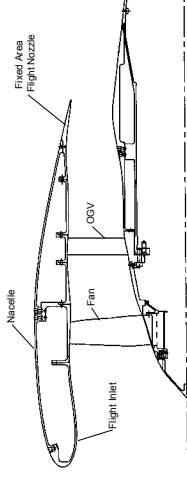
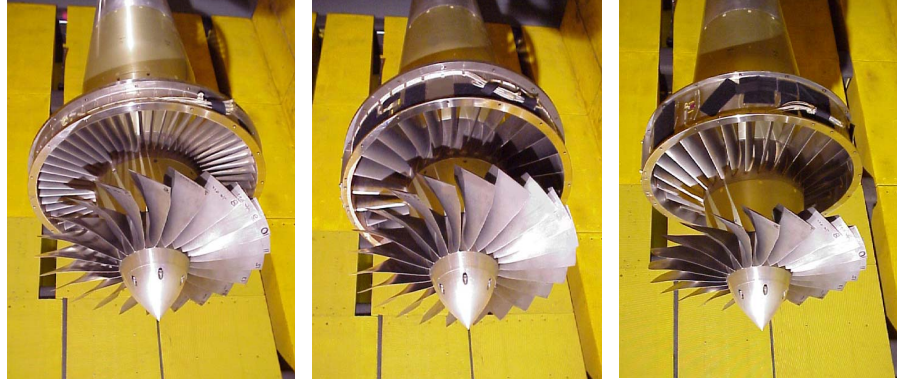

Baseline Radial (54 Vanes)

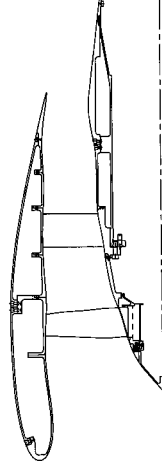

Low-Count Radial (26 Vanes)

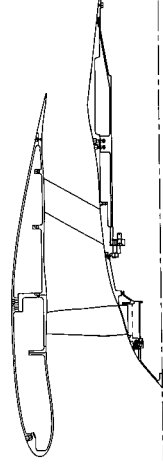

Low-Count Swept (26 Vanes)

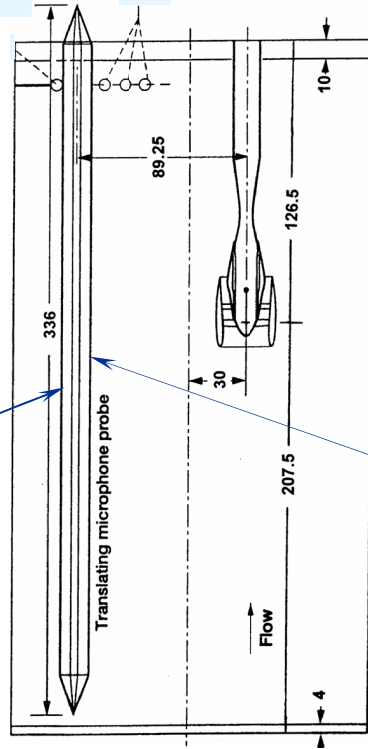

Farfield pressure spectra obtained at many microphone positions for several fan tip speeds.

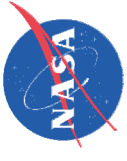

Noise Source Separation

□ Inlet vs. Exhaust

inlet + exhaust noise

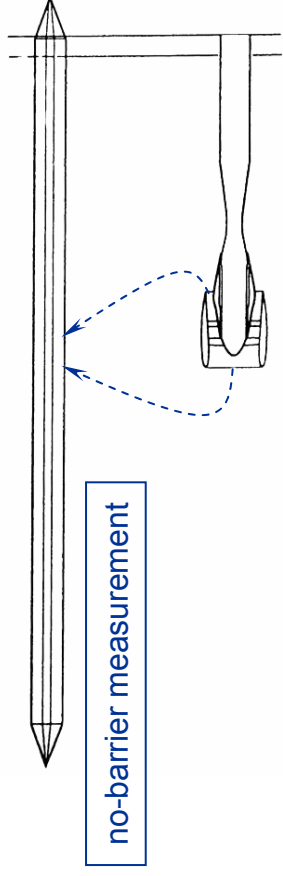

—

inlet noise

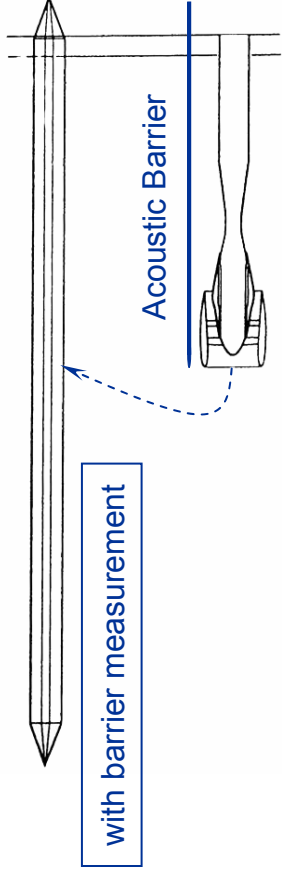

≡

exhaust noise

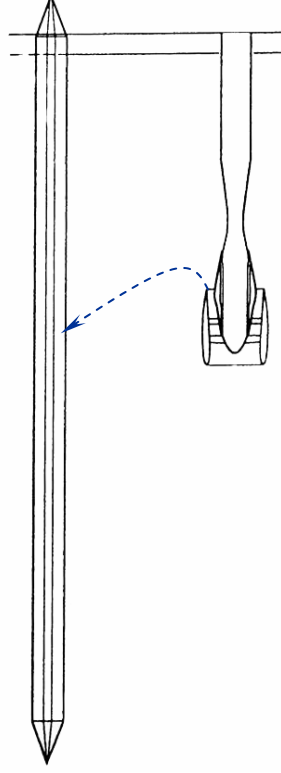

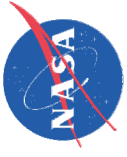

Noise Source Separation

□ Rotor vs. Stator

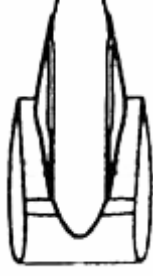
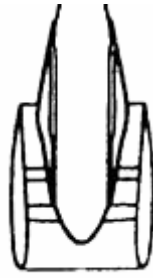

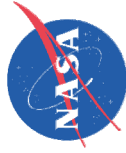

Noise Source Separation

EPNL Flyover Calculations -- Source Diagnostic Fan Test
 No Barrier Wall, 0.10 Mach Flyover
 R4 Rotor-Alone, No Stator

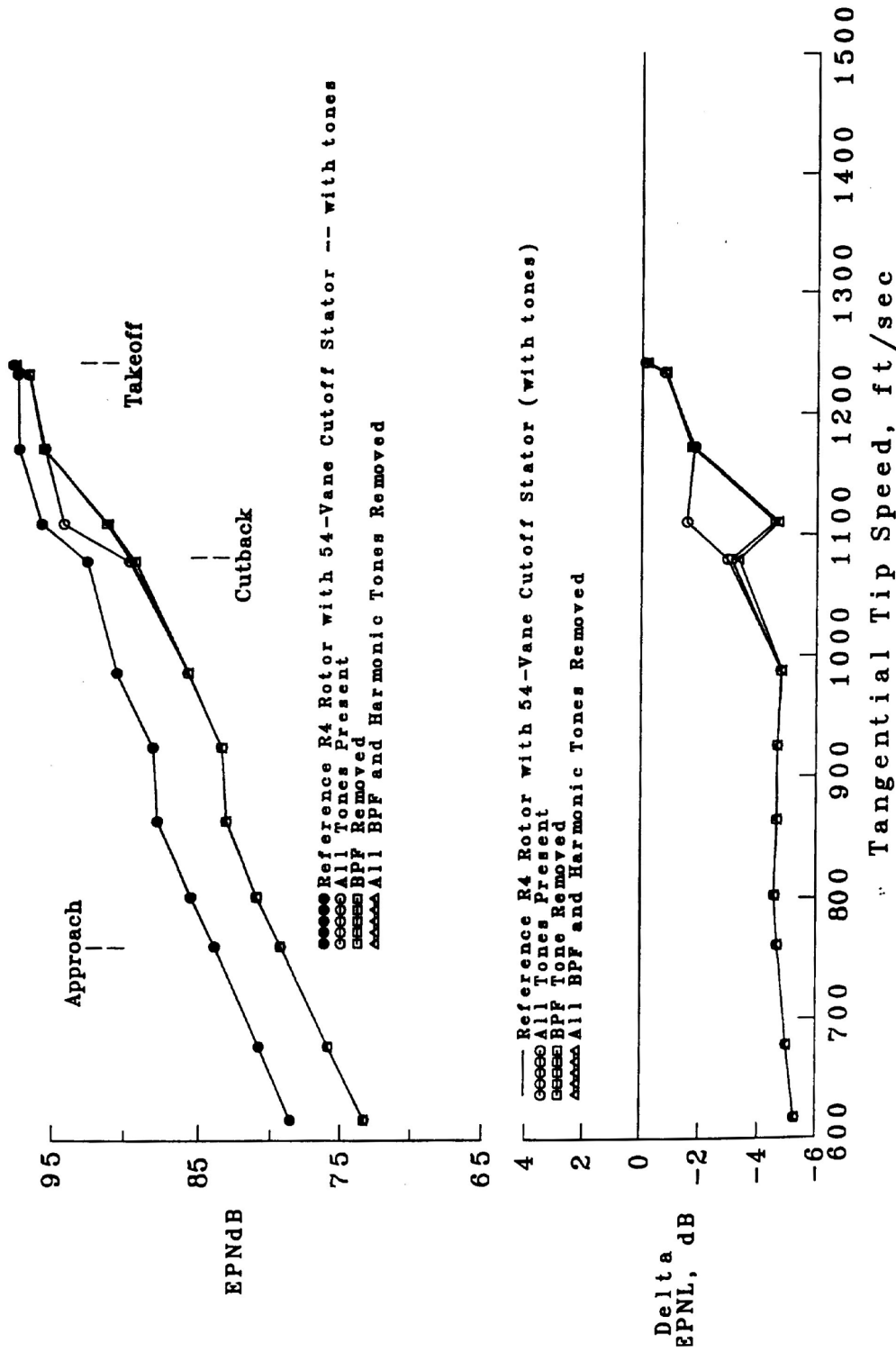

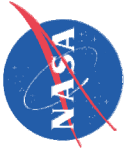

Broadband Noise Challenge

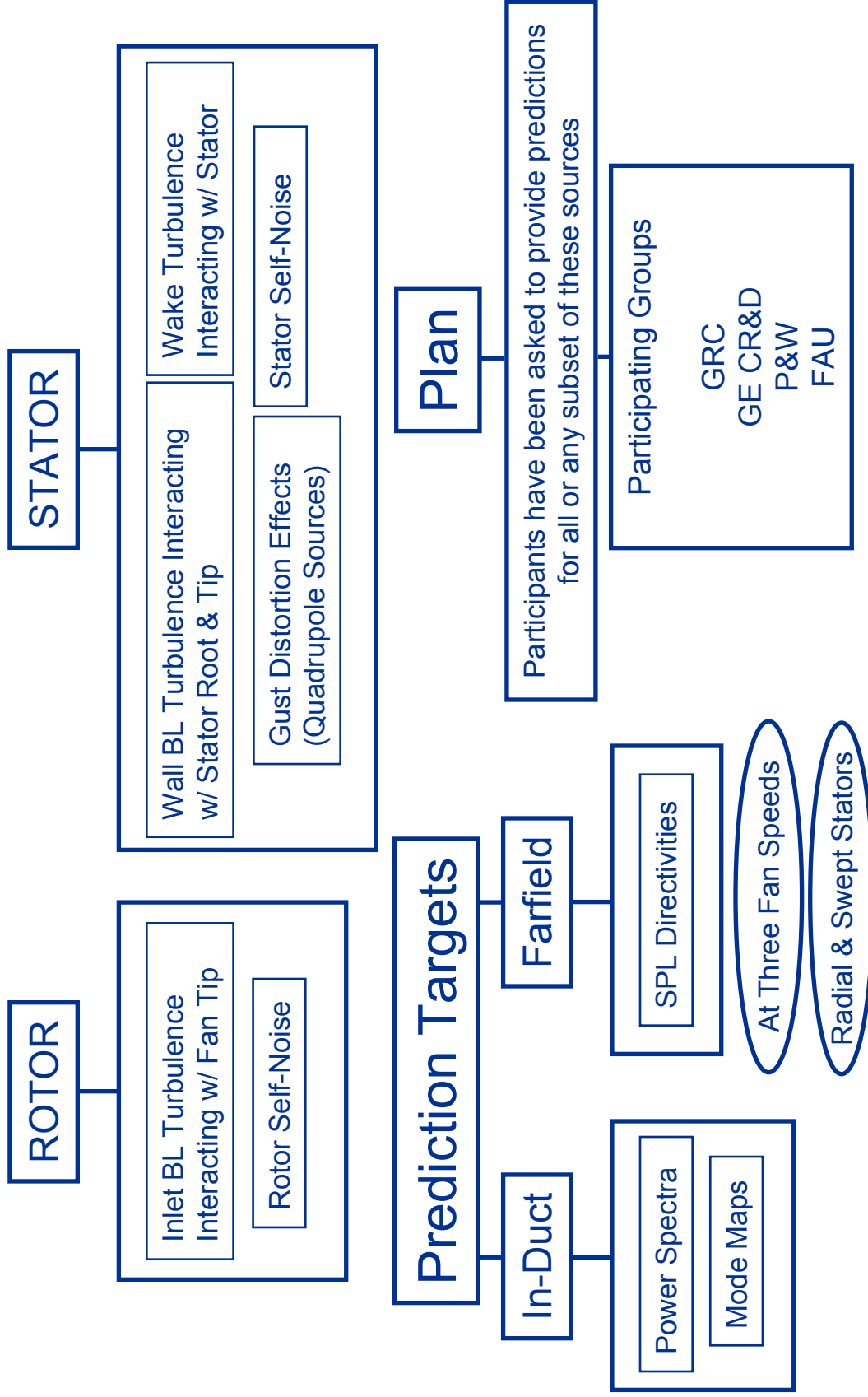

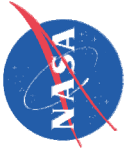

Broadband Noise Challenge

□ Noise Prediction Methodology

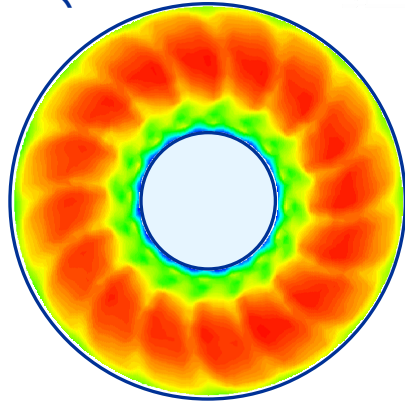

1. Predict Rotor Flowfield

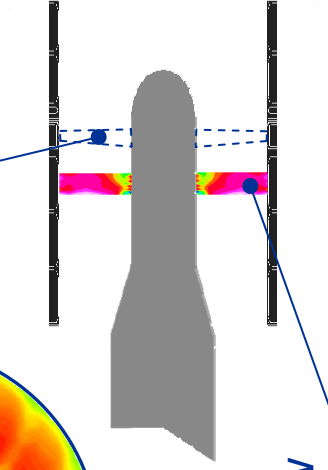

2. Predict Blade Row Unsteady Pressures

- APNASA Provides
 - Mean Flowfield
 - Turbulence k.e.

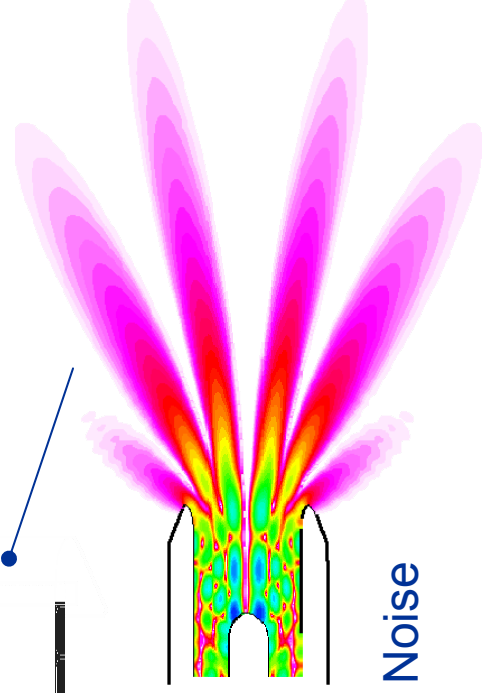

3. Predict Noise

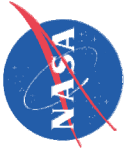

Broadband Noise Challenge

- ❑ **Fan and OGV Broadband Noise Codes**
 - ❑ BFaNS Code, Fan & OGV Noise, (B. Morin)
 - ❑ BBN Code, OGV Noise, (M. Nallasamy)
 - ❑ GE Code, Fan & OGV Noise, (R. Mani)
 - ❑ “Glegg” Code, Fan & OGV Noise, (S. Glegg)

- ❑ **Prediction of OGV Broadband Noise**
 - ❑ Baseline OGV (54 Radial Vanes)
 - ❑ Low-Count OGV (26 Radial Vanes)
 - ❑ Low-Noise OGV (26 Swept Vanes)
 - ❑ Fan Speeds: Approach, Cutback, Takeoff

- ❑ **Predictions of Fan + OGV Broadband Noise**
 - ❑ Same as Above with Fan BB Noise Contribution Included

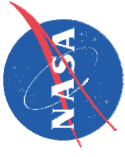

OGV Noise Predictions

Case 1

Baseline OGV (54 Radial Vanes), Takeoff Condition (12,656 rpm)

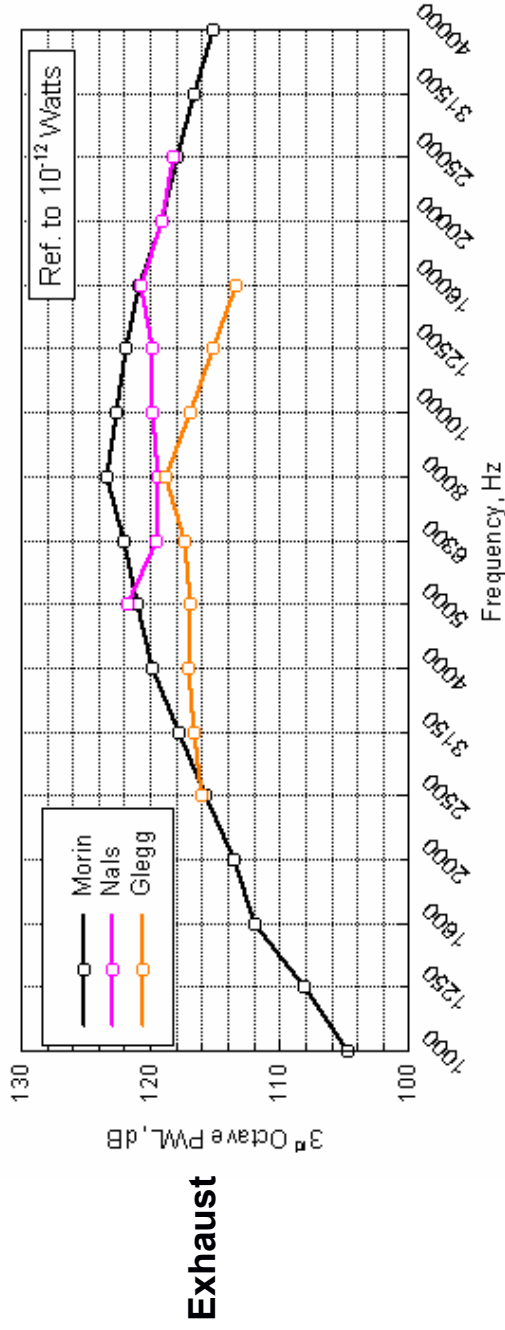
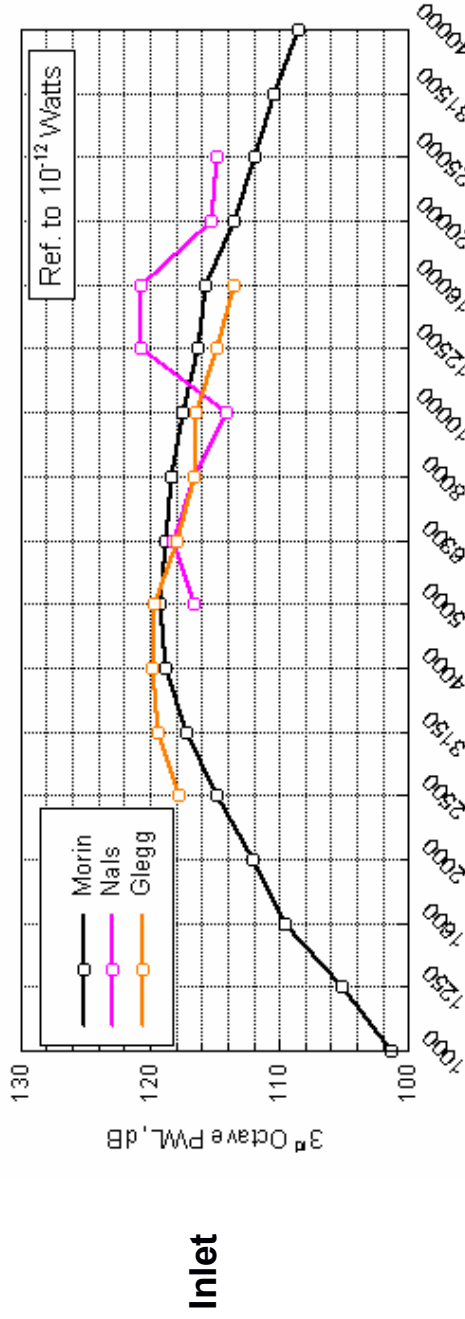

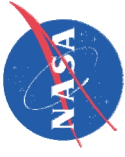

OGV Noise Predictions

Case 2

Baseline OGV (54 Radial Vanes), Cutback Condition (11,074 rpm)

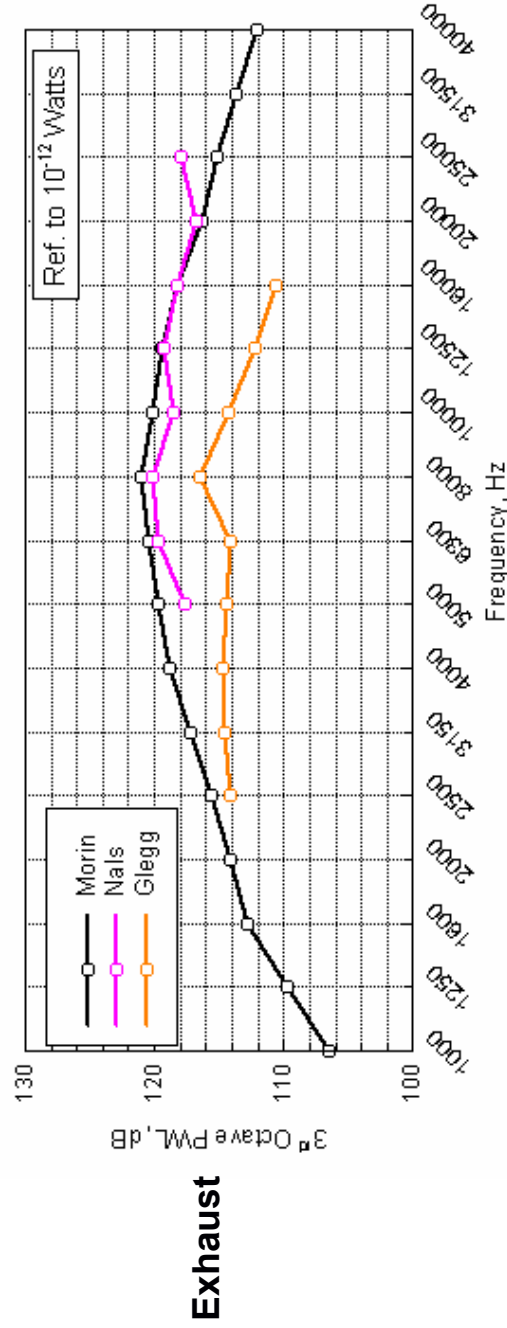
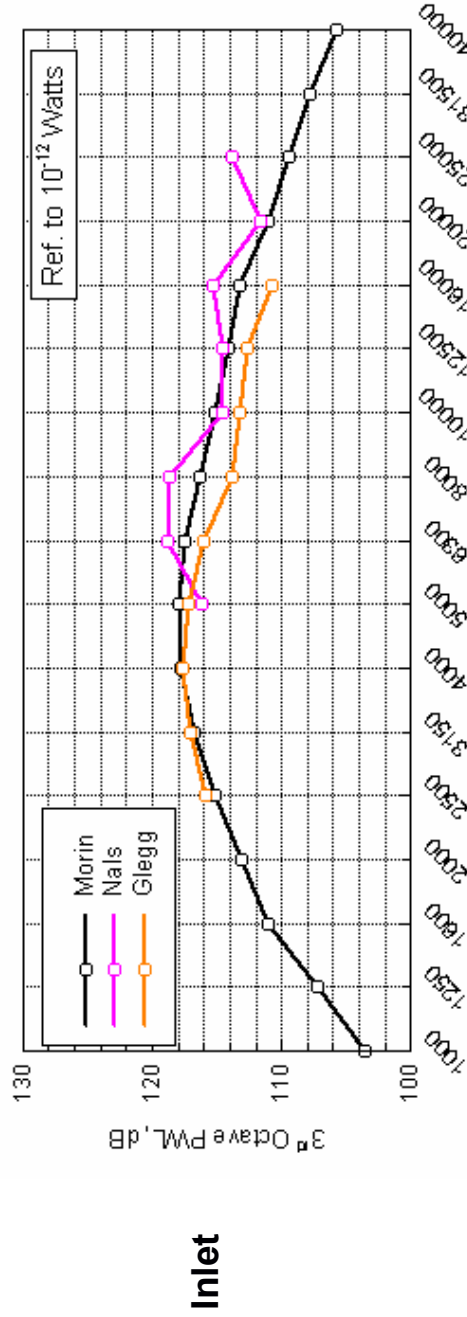

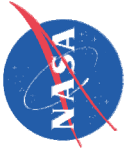

OGV Noise Predictions

Case 3

Baseline OGV (54 Radial Vanes), Approach Condition (7,808 rpm)

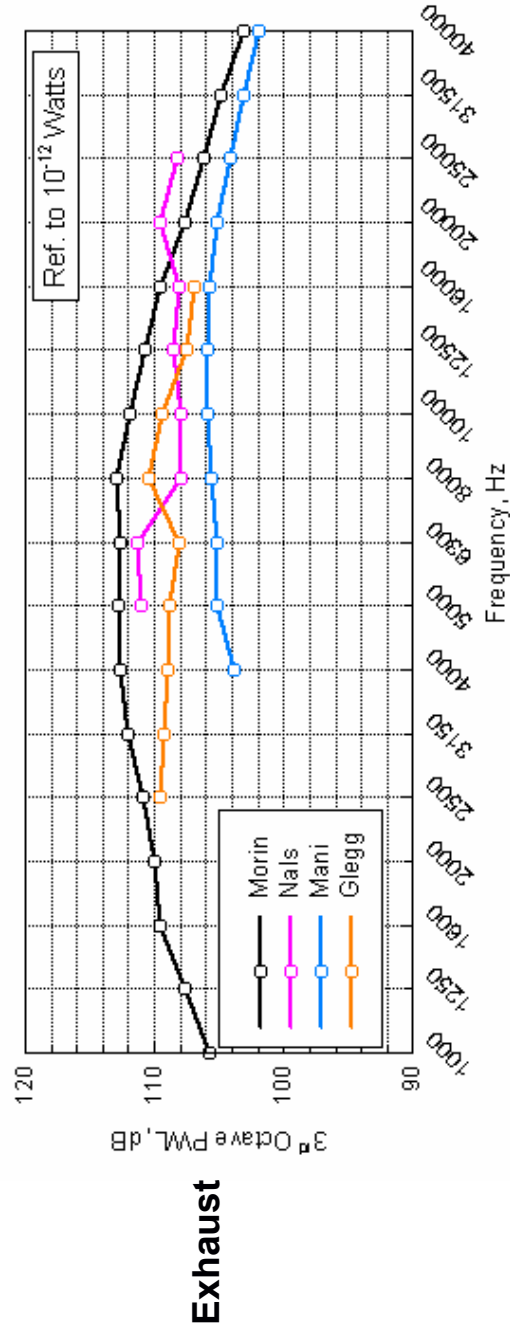
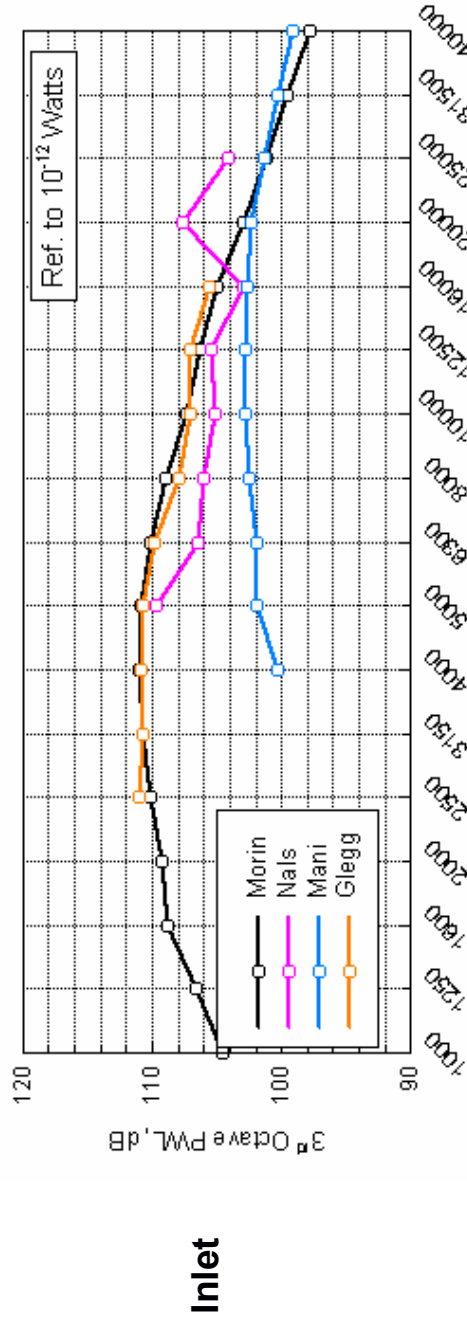

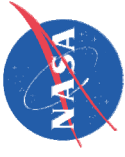

OGV Noise Predictions

Case 4

Low-Count OGV (26 Radial Vanes), Takeoff Condition (12,656 rpm)

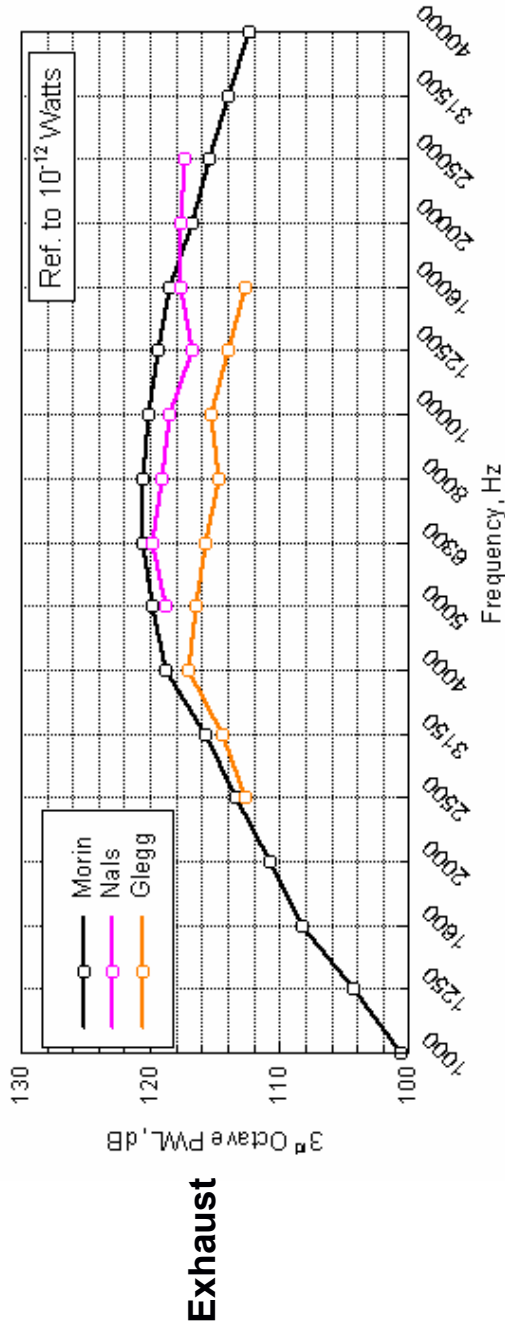
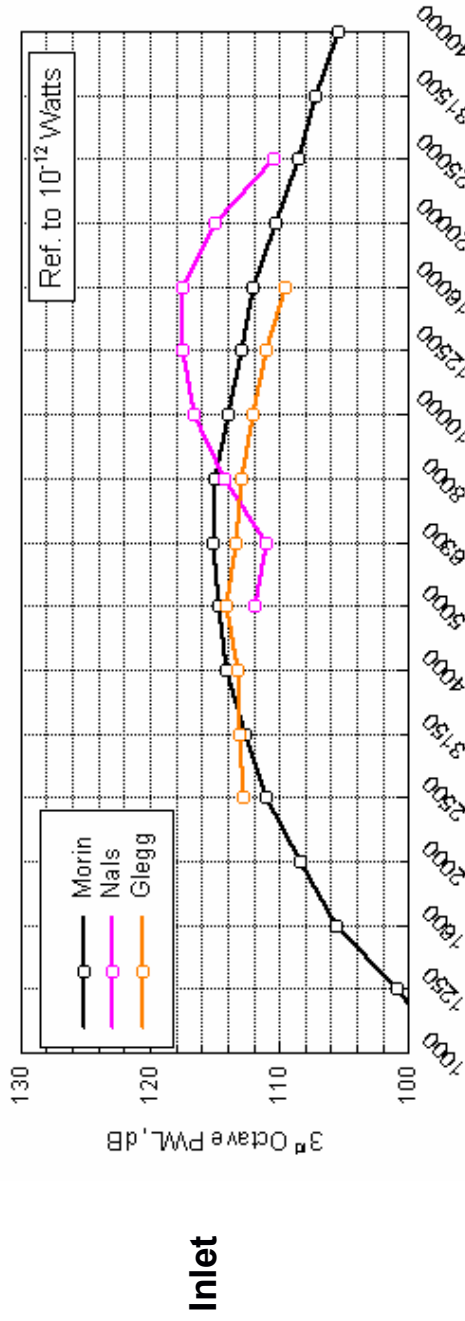

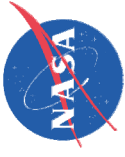

OGV Noise Predictions

Case 5

Low-Count OGV (26 Radial Vanes), Cutback Condition (11,074 rpm)

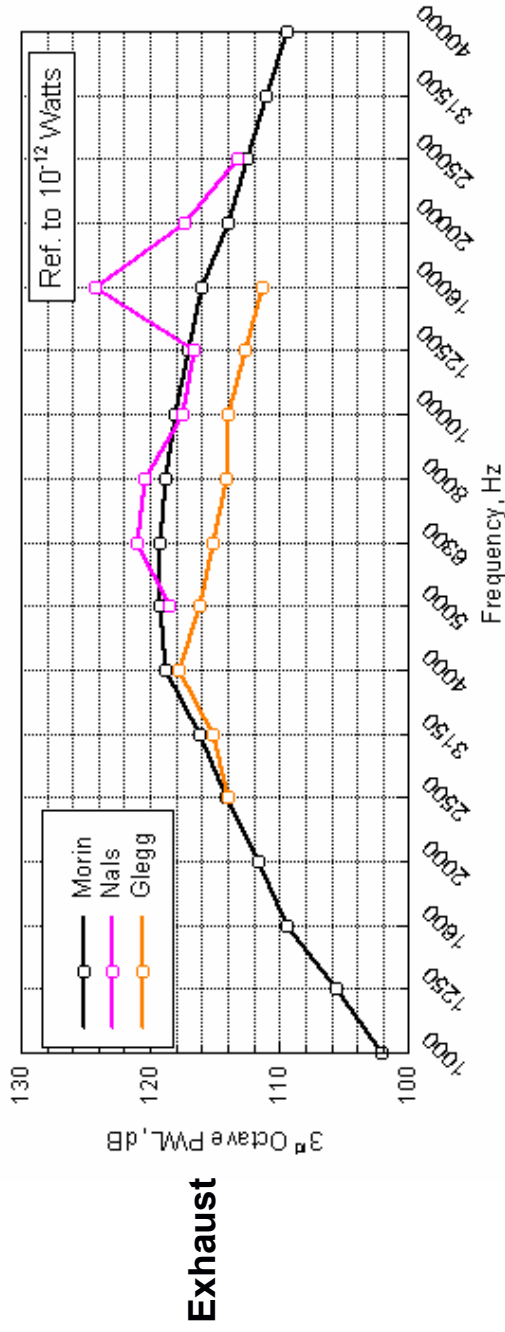
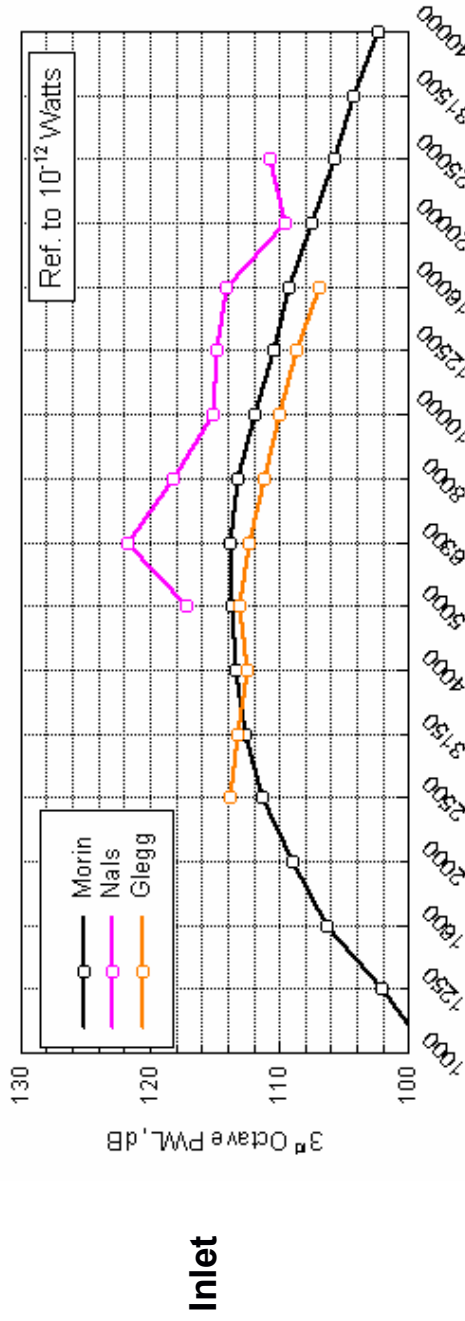

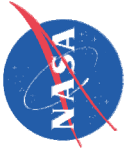

OGV Noise Predictions

Case 6

Low-Count OGV (26 Radial Vanes), Approach Condition (7,808 rpm)

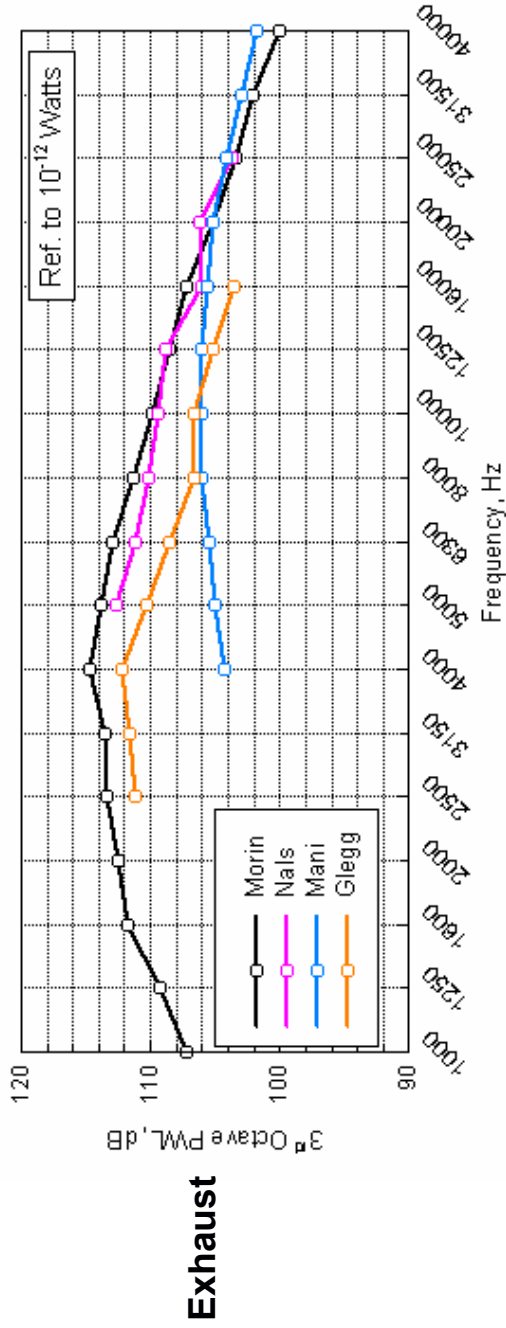
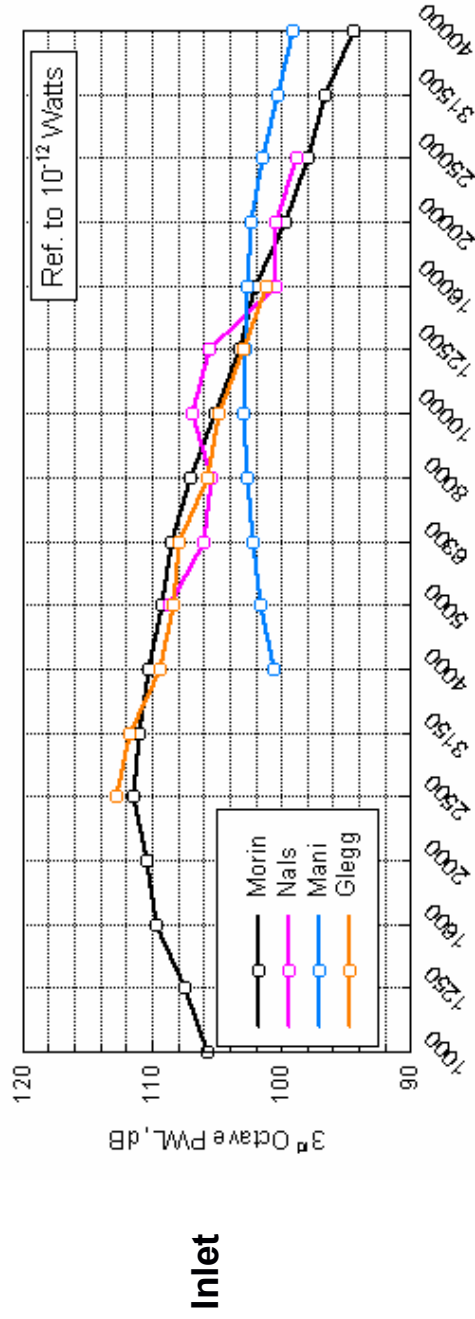

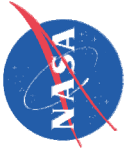

OGV Noise Predictions

Case 7

Low-Noise OG-V (26 Swept Vanes), Takeoff Condition (12,656 rpm)

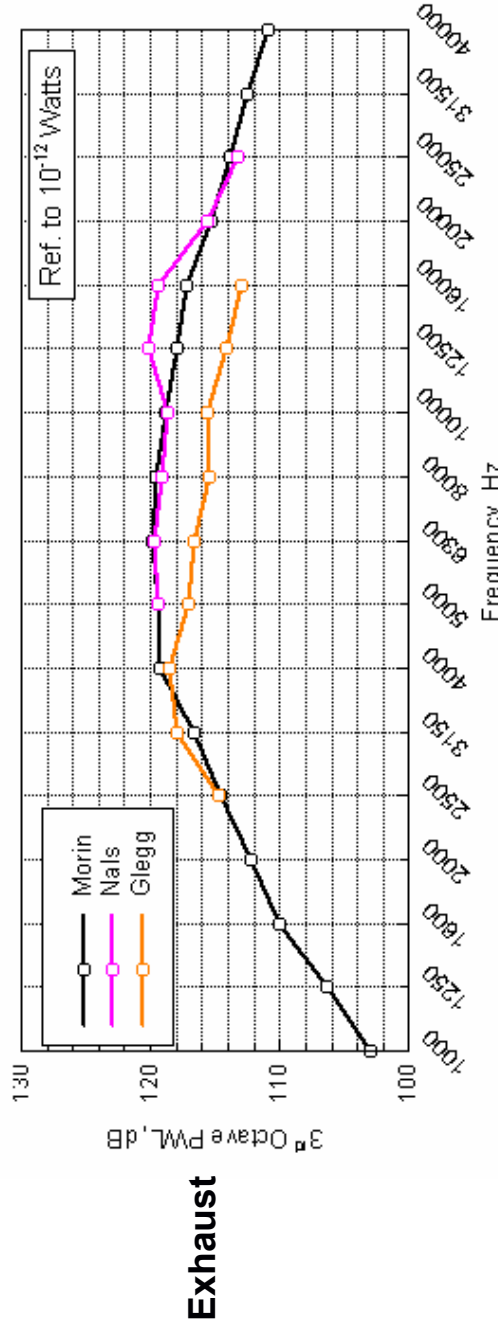
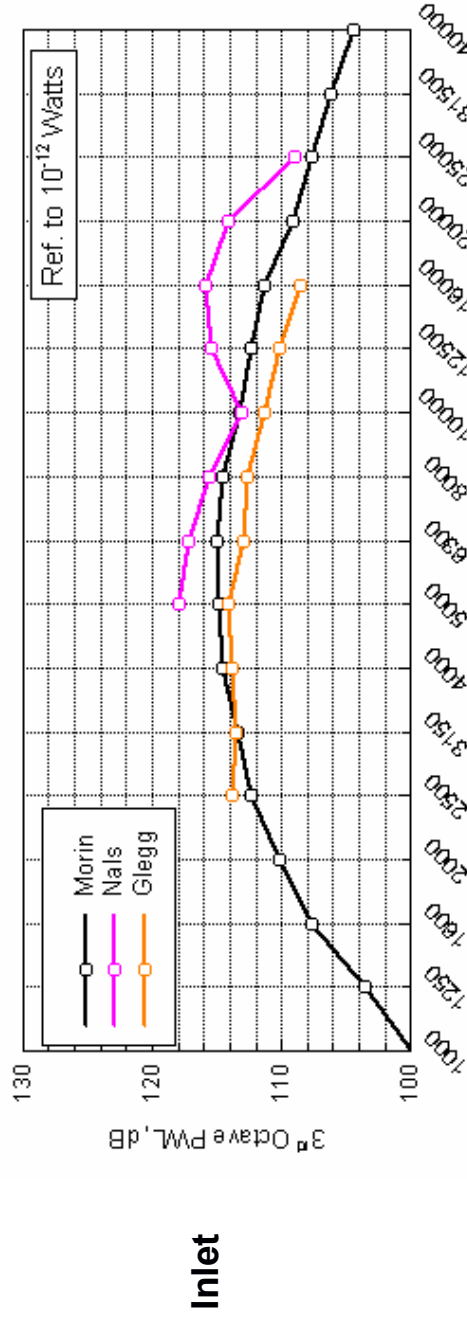

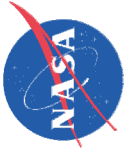

OGV Noise Predictions

Case 8

Low-Noise OGV (26 Swept Vanes), Cutback Condition (11,074 rpm)

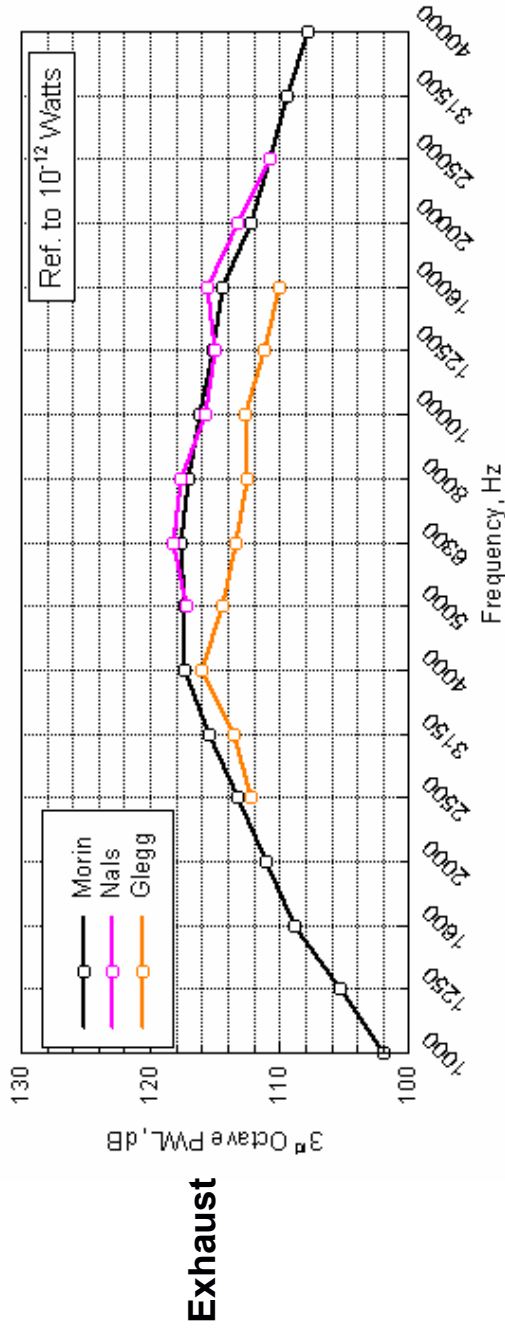
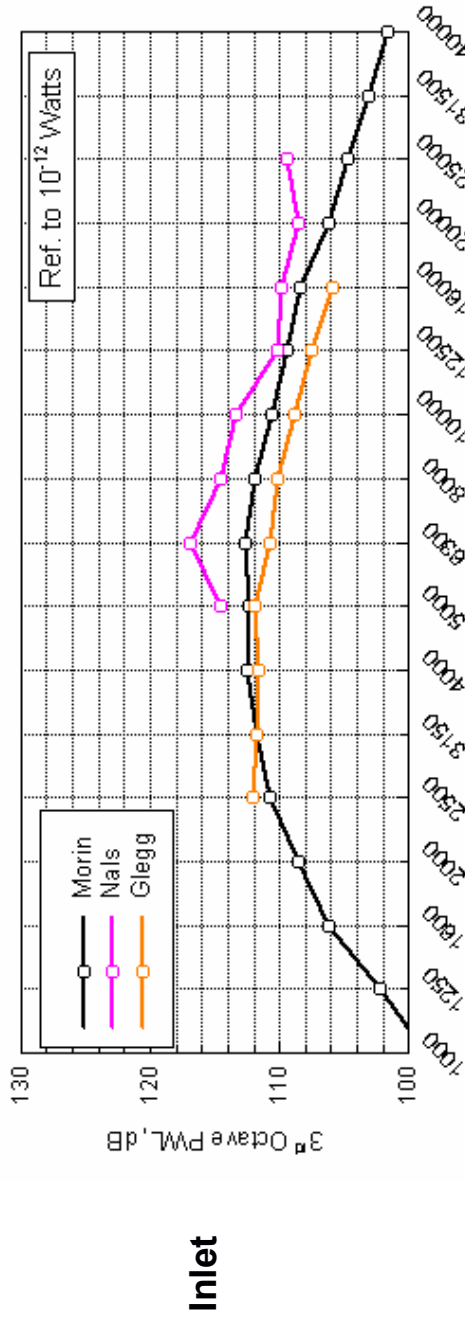

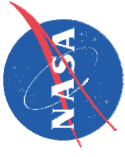

OGV Noise Predictions

Case 9

Low-Noise OGV (26 Swept Vanes), Approach Condition (7,808 rpm)

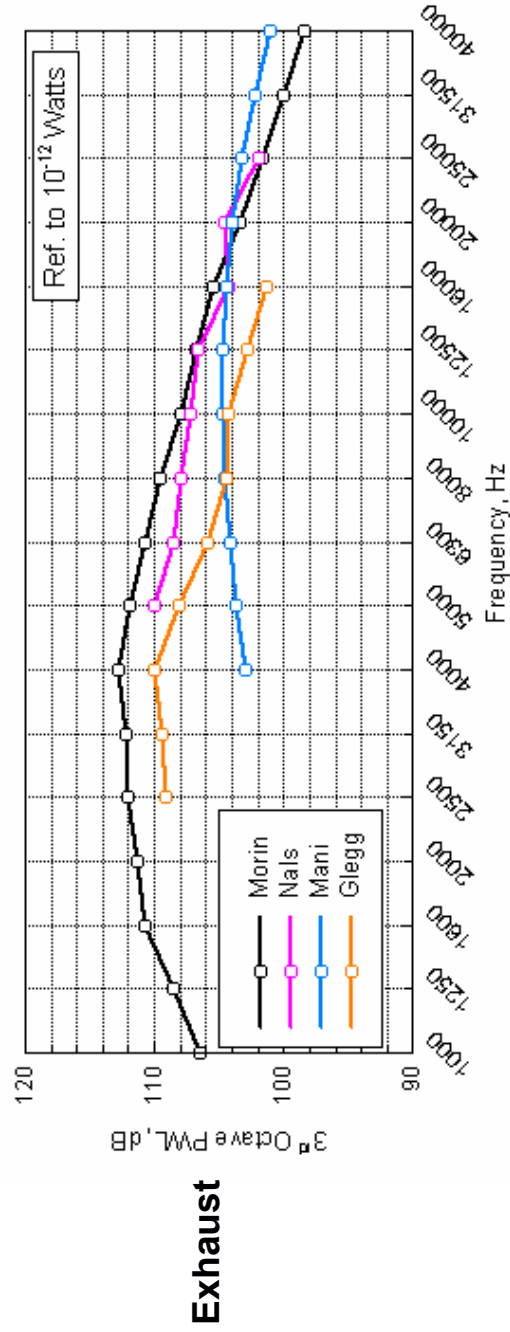
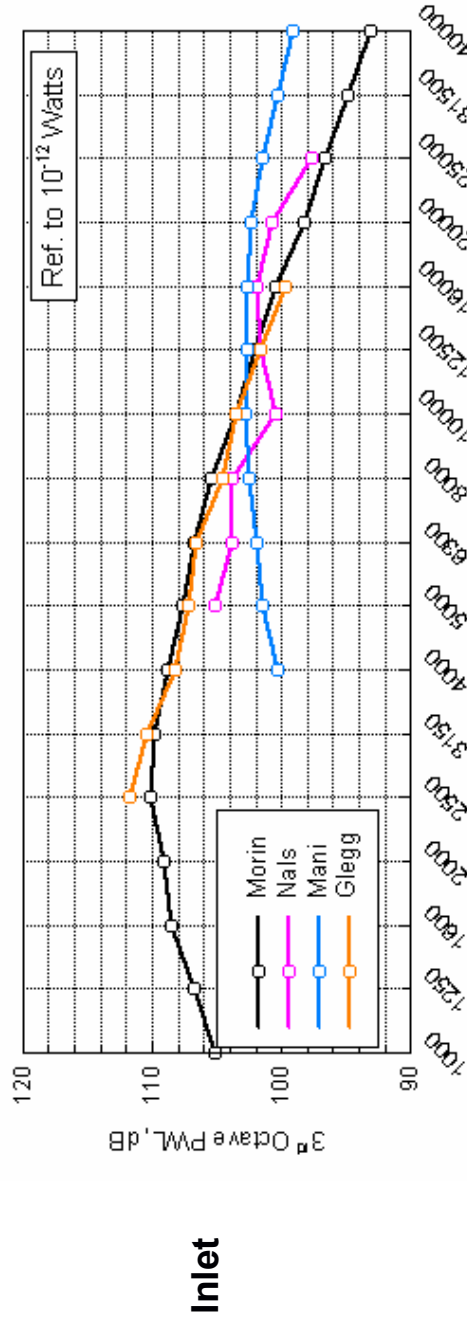

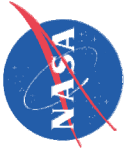

Data-Prediction Comparisons

- Baseline Radial OGV Spectra at Approach Speed
- BBN Code (Updated to improve cut-on modes and wake model)

Note the difference in scales

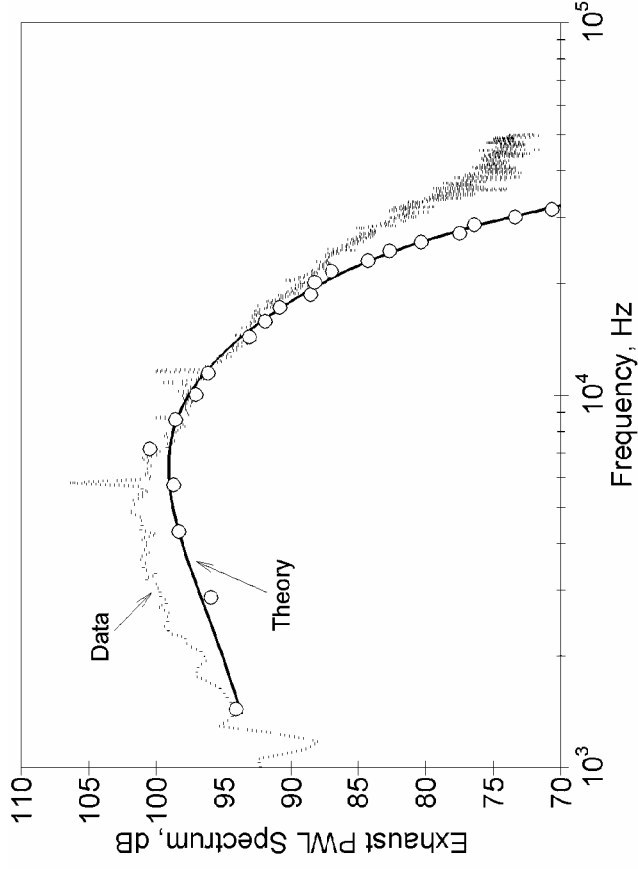
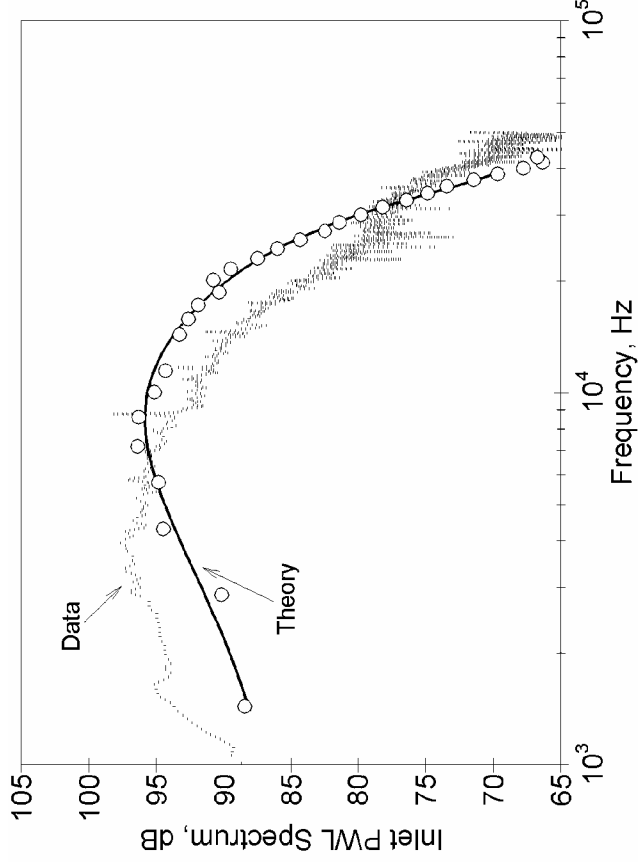

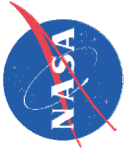

Data-Prediction Comparisons

- Low-Count Radial OGV Spectra at Approach Speed
- BBN Code (Updated to improve cut-on modes and wake model)

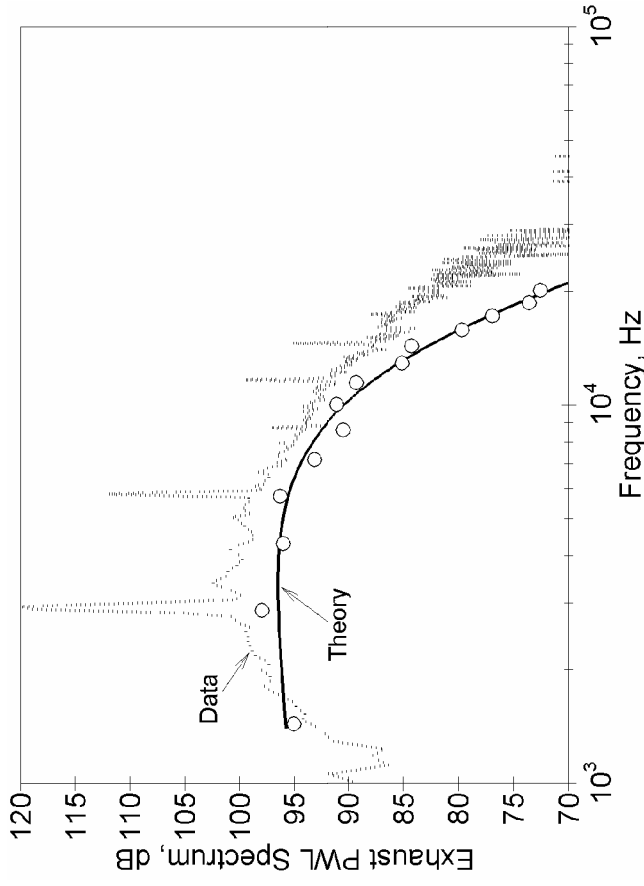
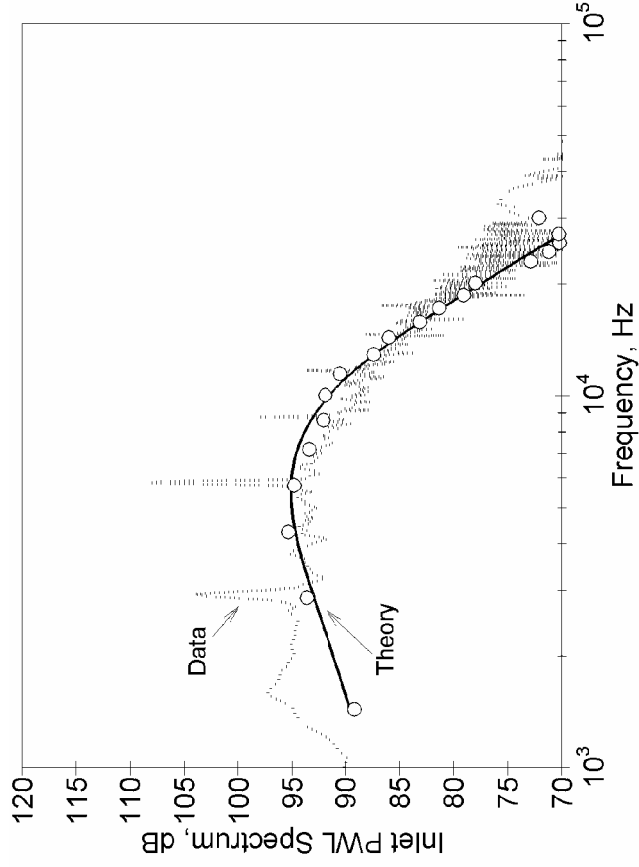

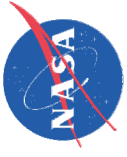

Data-Prediction Comparisons

- Low-Count Swept OGV Spectra at Approach Speed
- BBN Code (Updated to improve cut-on modes and wake model)

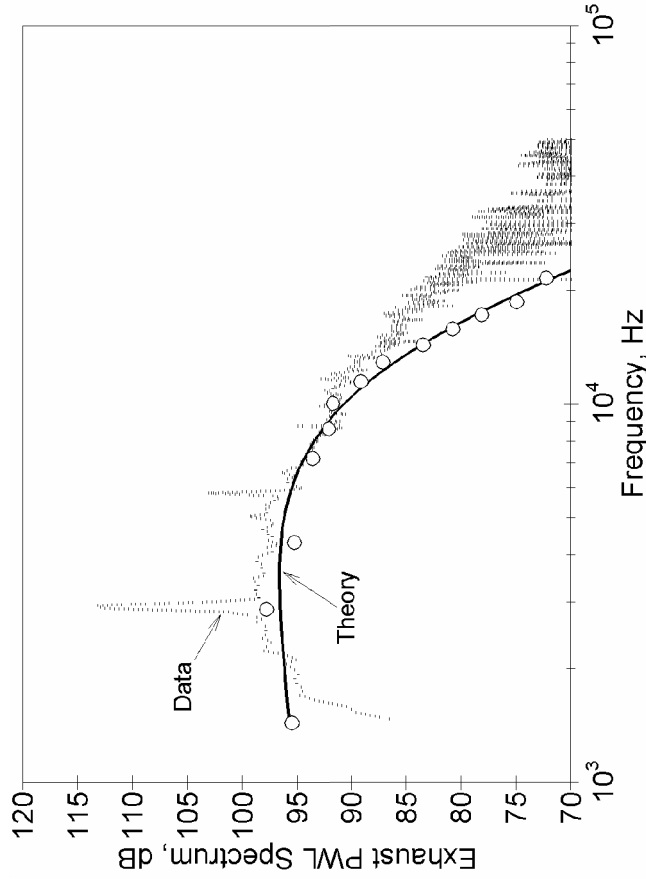
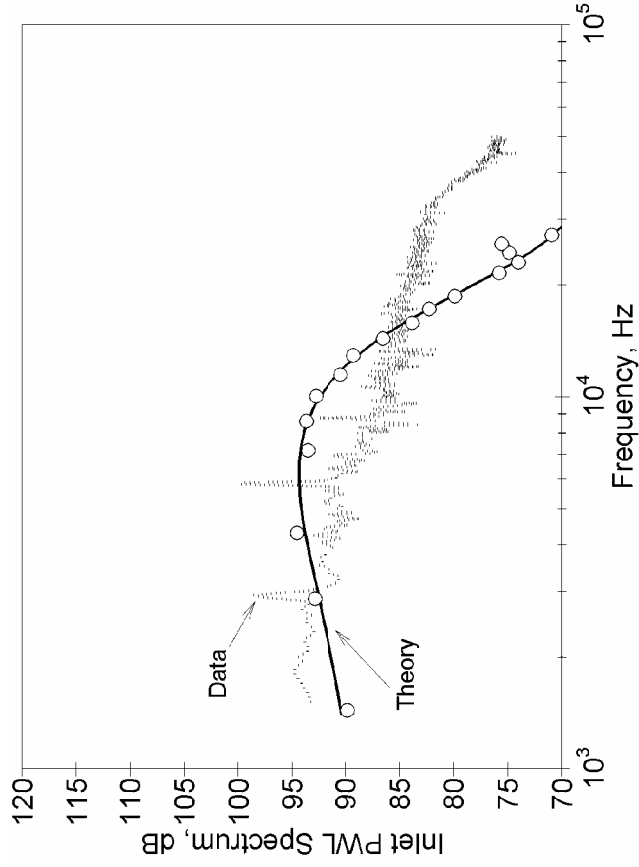

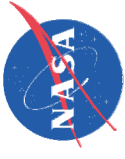

Summary

- Significant improvements have been made to fan noise prediction methods with focus on tone and broadband noise from rotor/stator interaction.
- Over the past 15 years, we have moved *from* classical empirical/computational methods *to* “Computational AeroAcoustic (CAA)” methods that compute the entire field.
- Tone predictions now include effects of mean flow, coupling between blade rows, higher frequency resolution, and improved source definition (wakes, tip flows, swirl, etc.).
- New broadband noise prediction methods have been developed that include better turbulence models for source definition; most methods predict duct sound power (limited directivity)
- More work needs to be done, particularly:
 - Methods for supersonic tip rotational speeds
 - Rotor self noise & blockage of inlet radiated stator noise through the fan
 - Integration of tone and broadband noise prediction methods
 - Source identification methods within the fan stage.

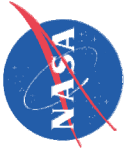

Fundamental Aeronautics Program Subsonic Fixed Wing Project

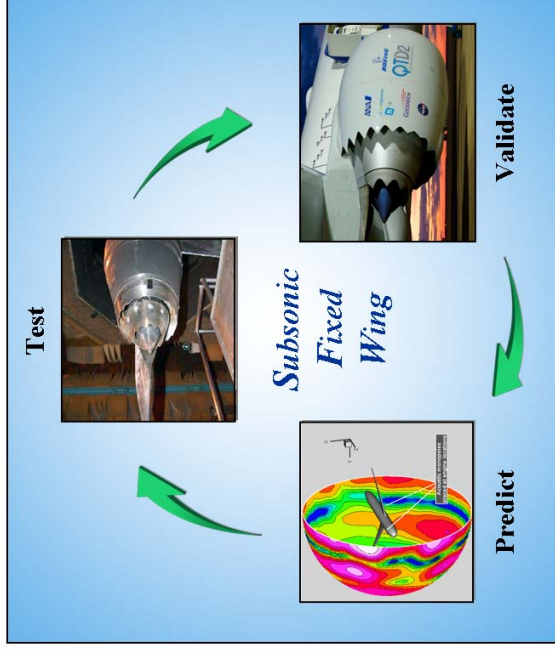

Principal Investigator: Dr. Fay Collier
Project Manager: Eddie Zavala
Project Scientist: Dennis Huff

August 4, 2006

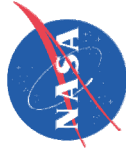

Noise Trends and Targets

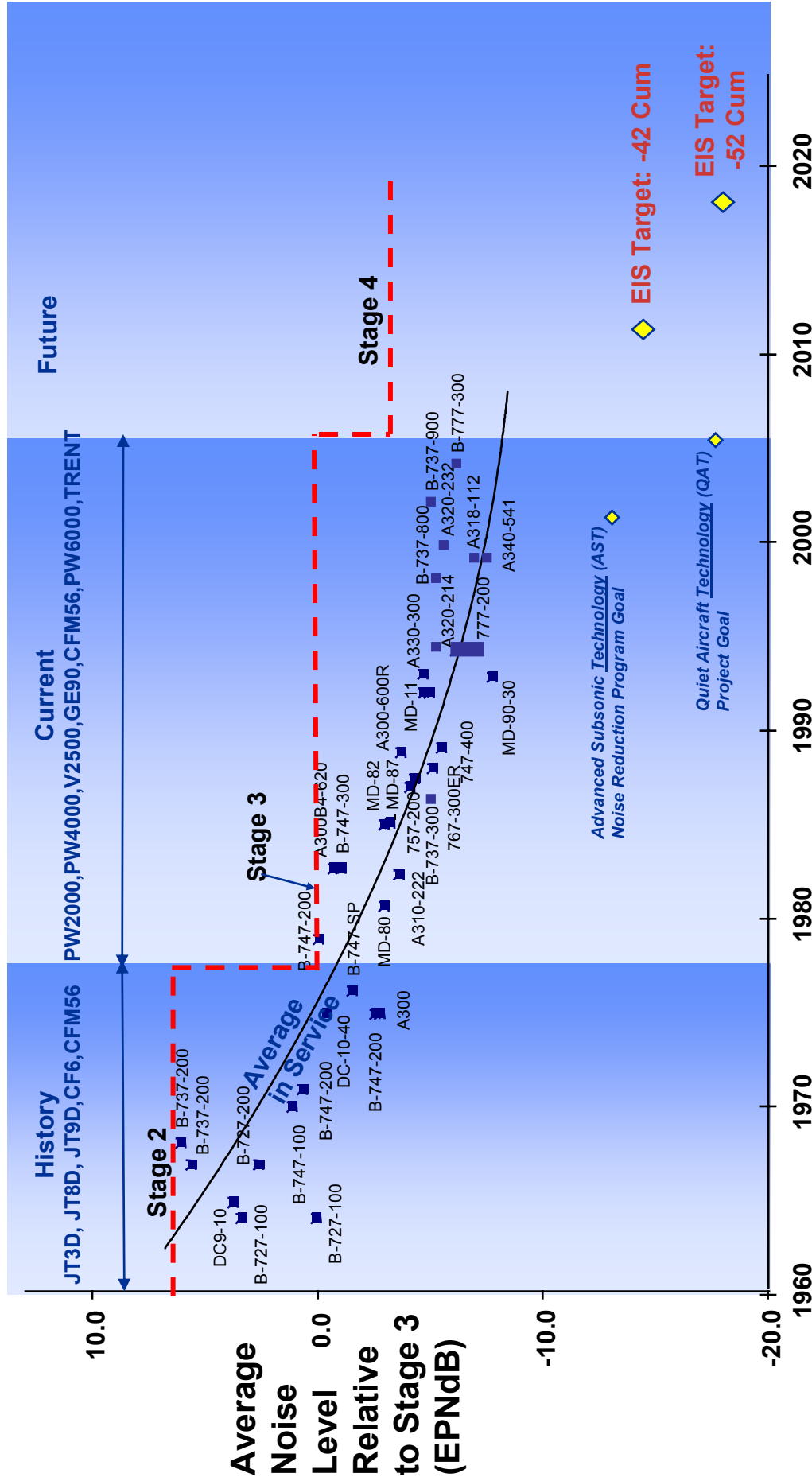

Year of Certification

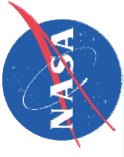

Acoustics

Objective:

Enable system-level trades of noise against other performance factors for conventional and unconventional aircraft and develop noise reduction technologies that have minimal impact on aircraft operation.

Approach:

Develop and validate multi-fidelity aircraft component and system noise prediction tools, and engine and airframe noise reduction technologies.

Focus:

Foundational and discipline level work in seven areas:

- Airframe Noise
- Jet Noise
- Cabin Noise
- Acoustic Propagation
- Turbomachinery Noise
- Advanced Liners
- Propulsion Airframe Aeroacoustics

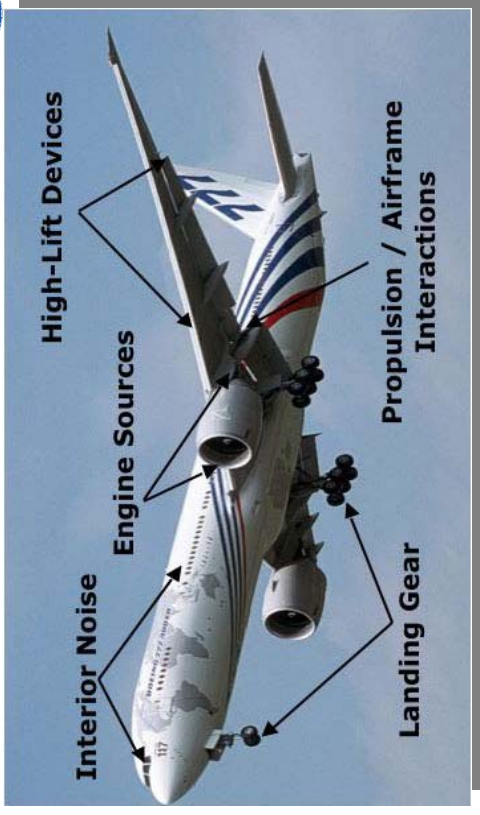

Aircraft Noise is a complex amalgam of sources, interactions, transmission and propagation.

Validation Strategy:

Noise Prediction: Reduce current data-theory error level by 50%.
Noise Reduction: Demonstrate noise reduction for aircraft components in the 2-4 “EPNdB” range relative to current SOA.
Key Metrics: Sound Pressure Level, Sound Power Level and noise directivity.

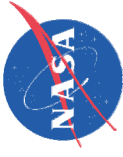

Highlights of Planned NASA In-House Research:

Foundational (Level 1):

- Large-Eddy Simulation for noise source computations
- Advanced methods for flow and noise field measurements
- Multi-function materials and smart materials for noise reduction

Discipline (Level 2):

- Assessment of current state of the art in aircraft noise prediction
- Development of reduced-order, multi-fidelity tools for component noise prediction
- Development of fast, accurate tools for long range acoustic propagation in real atmospheres
- Integration of component modules into an aircraft noise prediction capability beyond ANOPP
- Development of generic engine and airframe noise reduction technologies

Multi-Disciplinary and System Integration Work (Level 3 & 4):

- Evaluation of noise prediction tools within a multi-disciplinary & system level environment
- Demonstration of promising noise reduction technologies in wind tunnel, static engine and flight tests in cooperation with industry partners



NRA Investment (Level 1 & 2):

- Potential Phase 1 Research in:
- High-Fidelity Num. Simulations
 - Fundamental Experiments
 - Development of Efficient Noise Prediction Codes for Aircraft

Highlights of Partnership Strategy (Level 3 & 4):

- QTD Validation Tests with Boeing
- Test of the UHB Engine Concept with PW
- Flight Measure. of Turbulent BL Loads w/ Gulfstream
- X-48B BWB Test with Boeing
- Engine Noise Source Diagnostic Test with Honeywell
- Other Potential Partnerships Pending Further Discussions with NASA