

## **Designing for Our Future in Space**

Janis Connolly, M. Arch.

NASA Johnson Space Center – Habitability and Human Factors Office

NASA Rhode Island Space Grant Consortium

Spring Symposium: NASA in Rhode Island

April 28, 2007

### **Abstract**

Over the past several years, the disciplines of architecture and human factors have been increasingly recognized as specialties that have focused upon “human-centered design” in the development of spacecraft and surface habitats. These specialties have been instrumental in the conceptual design of overall spacecraft configurations and layouts, as well as habitability outfitting hardware, such as the galley, hygiene facility, sleep quarters, or the layout of displays and controls.

From the human-centered perspective, this approach to design assists in the mitigation of risk when designing for an extreme environment such as space. It takes into account the human’s physical and cognitive capabilities and limitations, the human’s performance in the context of human space flight, the human’s interaction with machines that are both physically and cognitively complex, the activities required of the human to accomplish the goals of missions, and the use of design practices that promote products to enable human activity.

It is this latter aspect – the use of design practices that promote products to enable human activity – that is the focus of the approach used by the Rhode Island School of Design (RISD) in collaboration with the Habitability and Human Factors Branch (HHFB) at the NASA Johnson Space Center (JSC). During the past few years, there has been a growing recognition of the value added by utilizing industrial designers to further the conceptual development of space hardware, that when used in conjunction with architecture and human factors, provides a robust solution to the design challenge.

The “Design for Extreme Environments” Studio at RISD has taken suggested design topics from the NASA JSC HHFB and asked the students to investigate solutions to these challenges. The topics have demanded that the student pay particular attention to a variety of aspects of the space environment and understand how the human responds to each. The student must then adapt the design to these responses. The studio environment has been one way to introduce these challenges, but providing for an “in-residence” opportunity at JSC has given the students a broader vision and set of experiences. The accompanying presentation highlights the studio as well as in-residence work that has been accomplished.



# Designing For Our Future in Space

*Janis Connolly, M. Arch.*  
NASA-Johnson Space  
Center

**NASA Rhode Island Space Grant Consortium  
Spring Symposium: NASA in Rhode Island  
April 28, 2007**

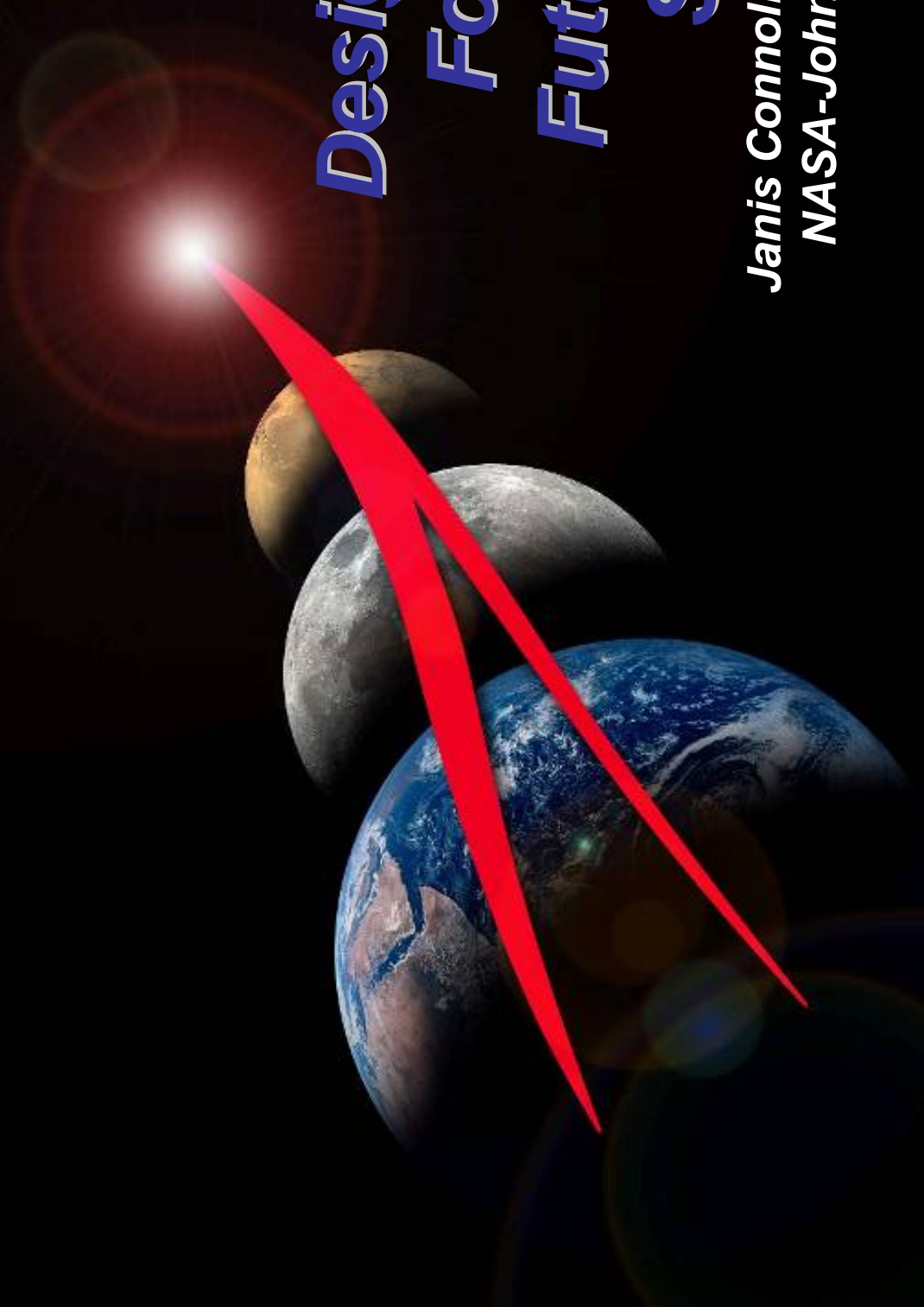



*The human is the pathway to exploration...*

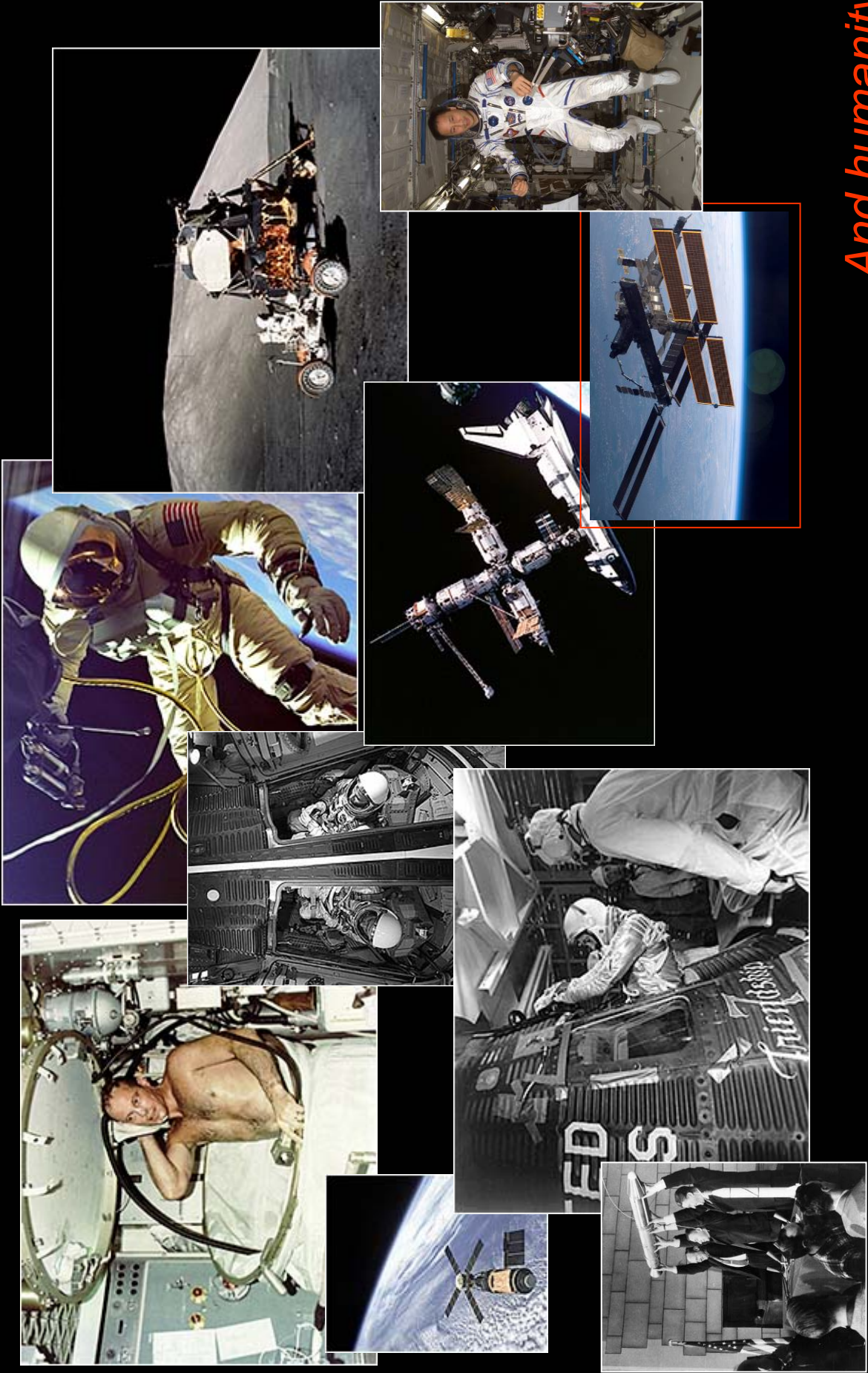

*And humanity continues to take steps further from its cradle....*

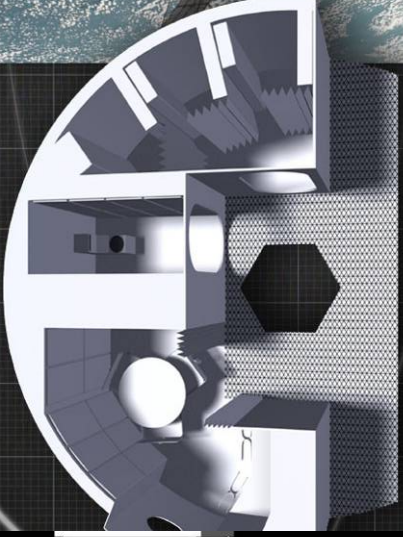
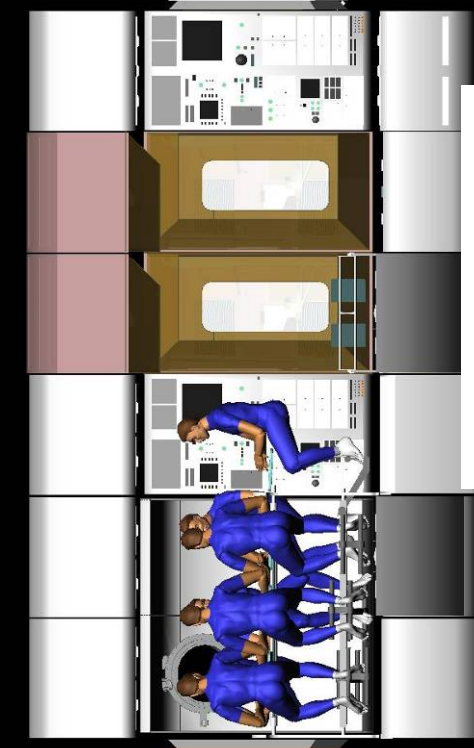
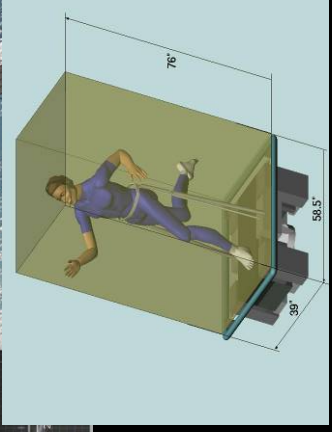
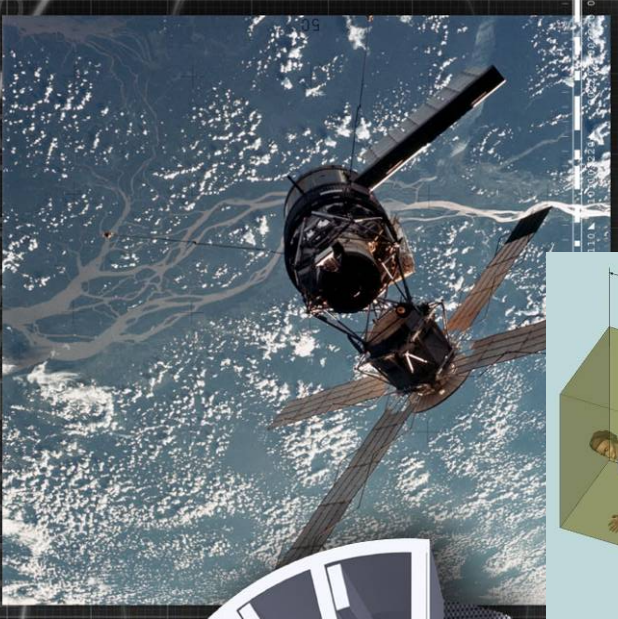

002 00220 092 002222 002220 002 022000 020011110 10110

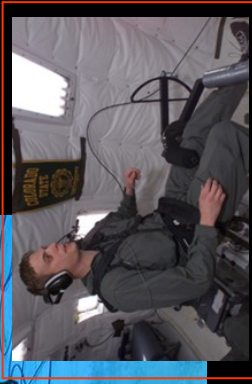
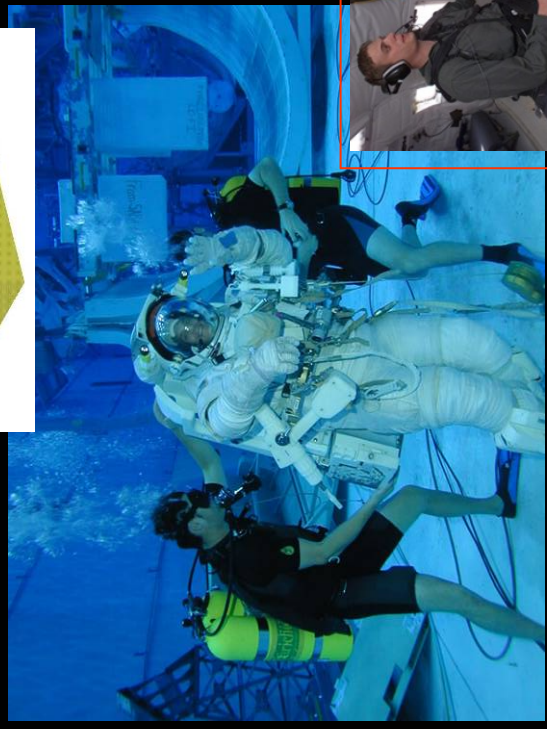
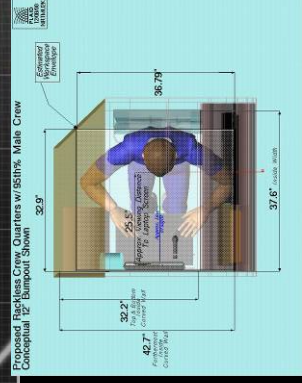

And each step teaches us a little bit more ..... so, we must learn and remember.....

*Designing for the human in space  
needs to draw not only on  
engineering, but must approach  
design from a “human-centered”  
perspective...*

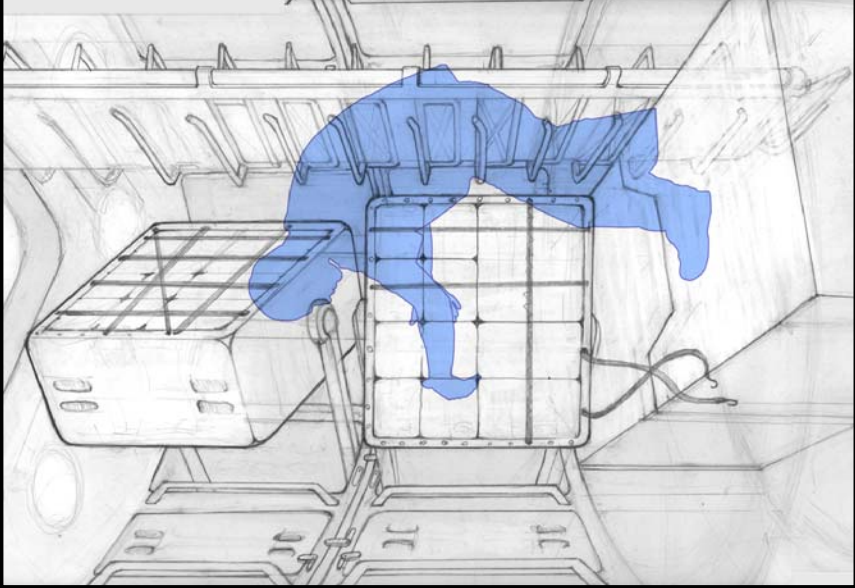
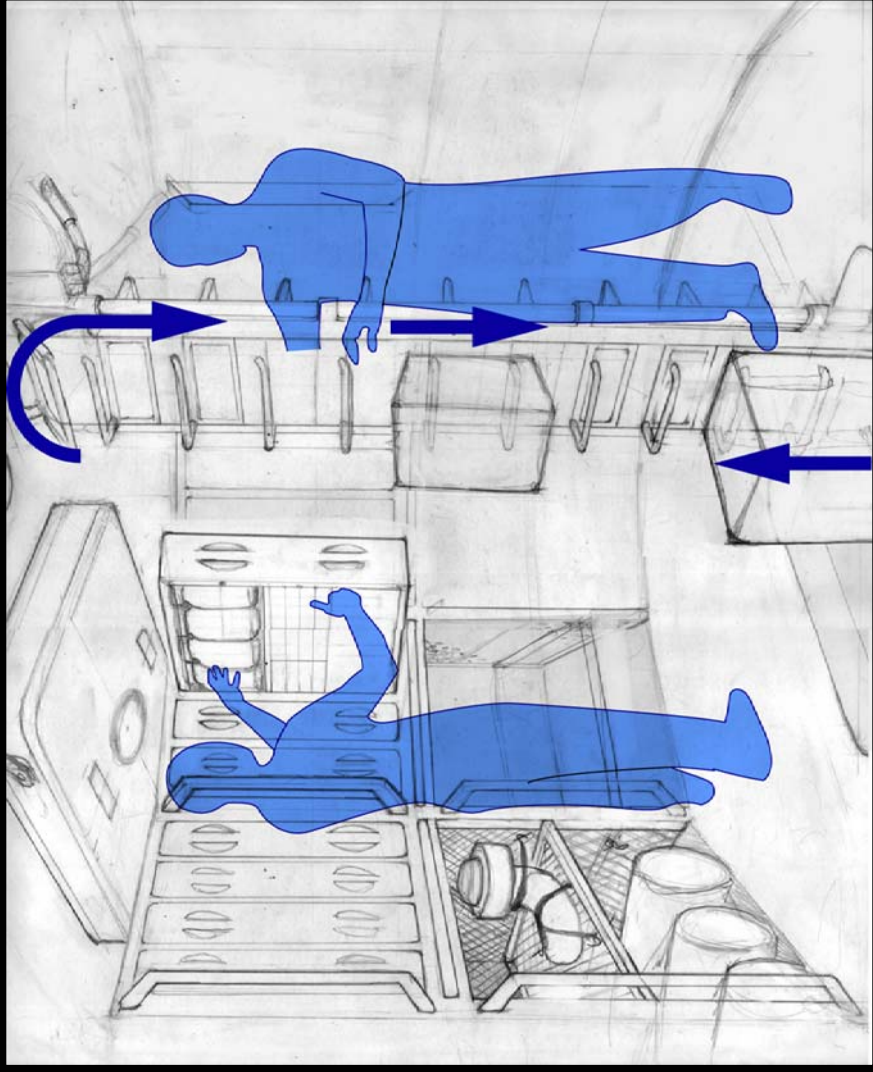
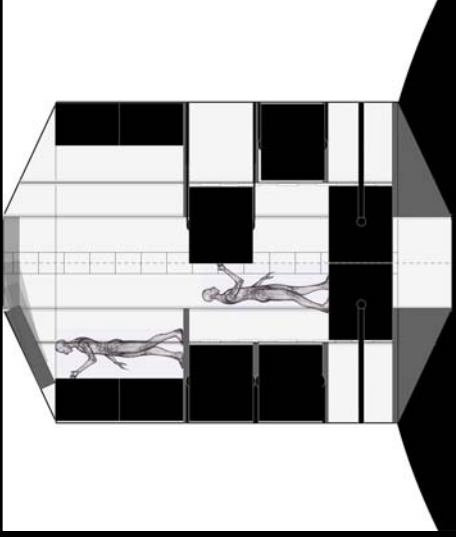

*“Design  
Challenge”  
projects provide a  
real-world  
opportunity to  
help NASA.....*

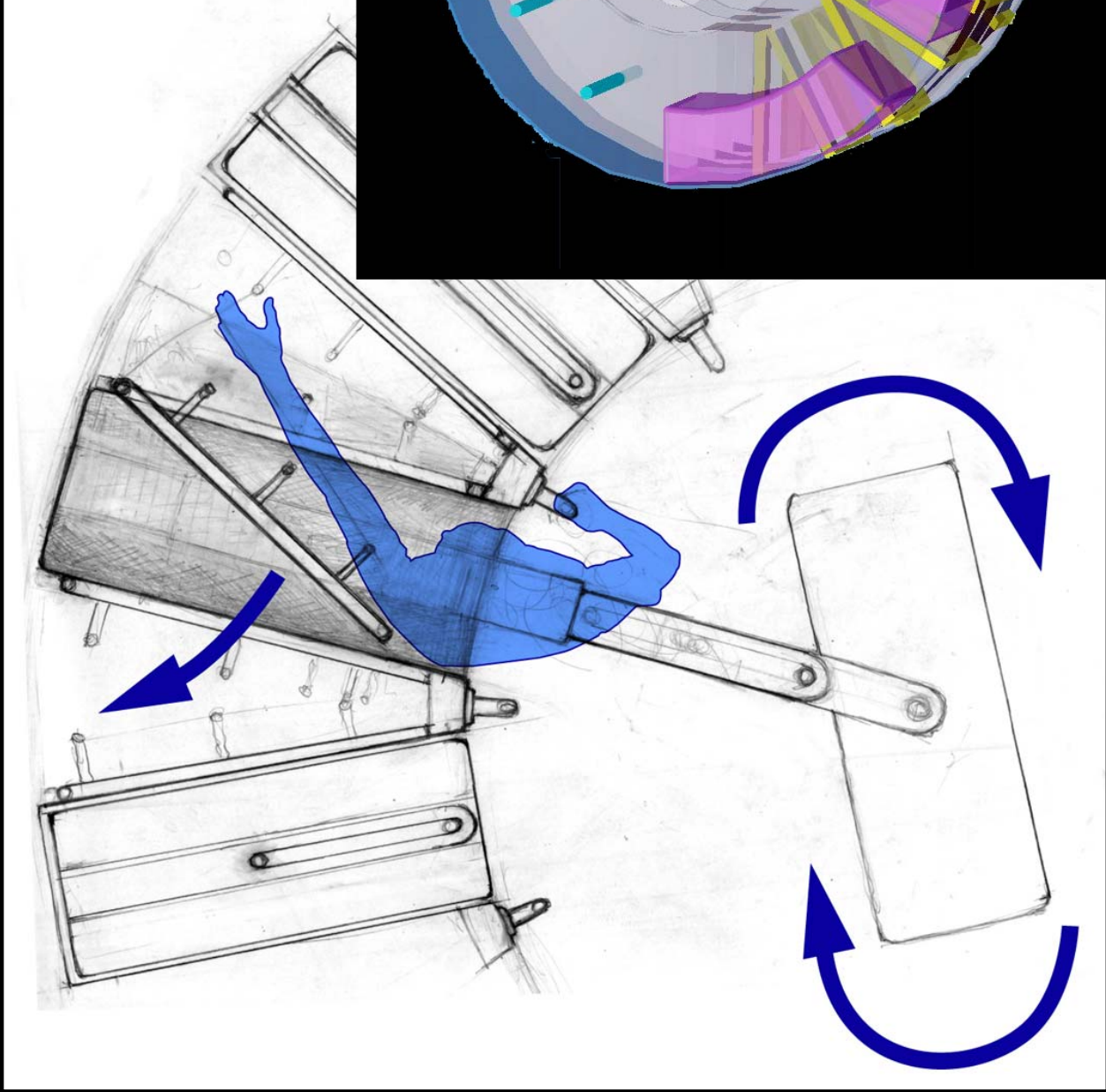

# Respiratory Support Pack Design Project



1. Medical Equipment is covered up & hidden from the viewer.
2. Medical equipment is not laid out according to order of use.
3. Equipment is not clearly labeled.
4. No instruction booklet.
5. Equipment inside is too cluttered.

*concerns with existing RSP....*

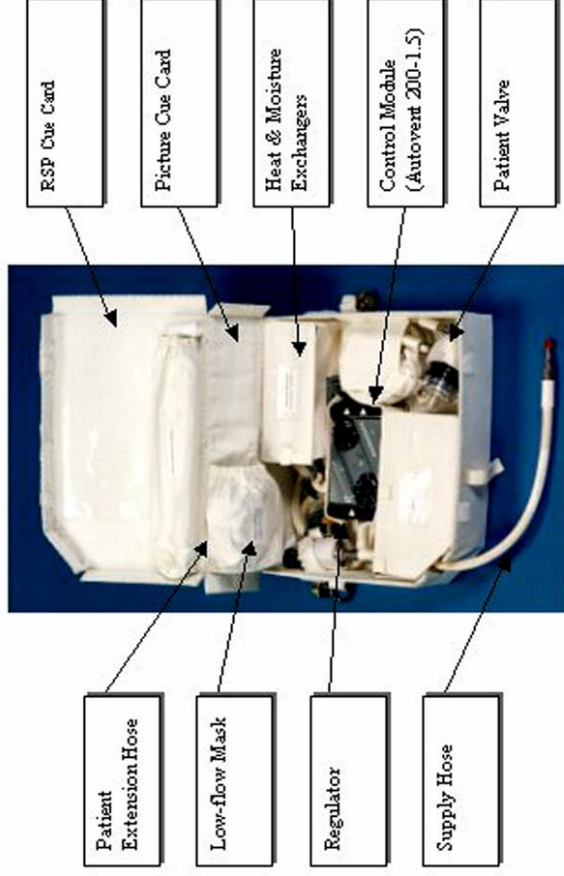



# Respiratory Support Pack Cue Cards



## RESPIRATORY SUPPORT PACK CUE CARD #1

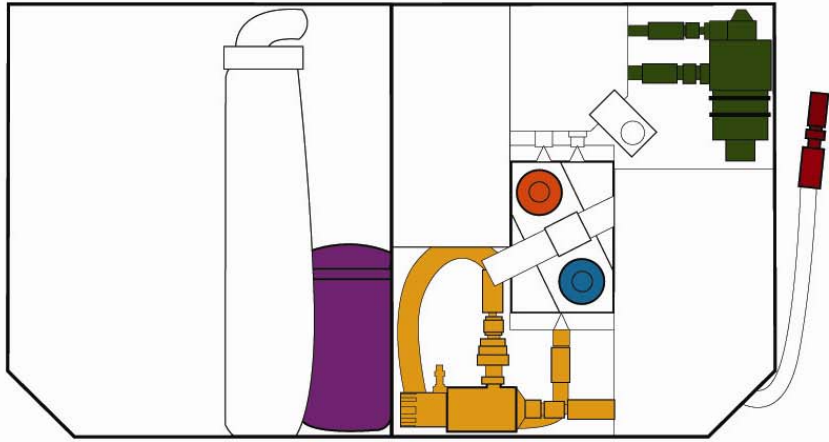

### UNCONSCIOUS PATIENT

- 1 Deploy RSP, ALSP, and Defibrillator
- 2 Remove **metal dustcap** from regulator supply hose and connect to (O2) supply (\*\* If CHeCs is unavailable, use PBA)
- 3 Set Autovent **BPM knob** = dot (●)
- 4 Set **Regulator** flow rate = 12  
Caution: Use WHITE indicator Line
- 5 Retrieve blue Ambu Bag from ALSP and attach (o2) tubing to RSP **Regulator** hose barb
- 6 Place Ambu Bag on patient and give 1 breath every 5 sec while preparing ILMA in ALSP .
- 7 Insert ILMA using ILMA cue card in IAK
- 8 Set **Regulator** flow rate = 0  
Caution: Use WHITE indicator line
- 9 Set Autovent **BPM** = 12
- 10 Set Autovent **Tidal Volume** = 800
- 11 Check for movement of green indicator on top of patient valve and feel for (o2) flow.
- 12 Attach **Patient Valve** to ILMA
- 13 Contact Flight Surgeon. Monitor Patient.

### CONSCIOUS PATIENT

- 1 Deploy RSP, ALSP, and Defibrillator
- 2 Remove **metal dustcap** from Regulator supply hose and connect to (o2) supply (\*\* if CHeCs is unavailable, use PBA)
- 3 Set Autovent **BPM knob** = dot (●)
- 4 Set **Regulator** flow rate = 12  
(Caution use WHITE indicator line)
- 5 Remove **Low Flow Mask** from RSP lid pocket and attach (o2) tubing to **Regulator** hose barb
- 6 Put mask on patient
- 7 Contact Flight Surgeon. Monitor Patient

# Wireless Crew Communication Project



## *Challenges with Existing Headsets*



*Limits usability range, wire tangle, obstruction, bulky headsets, needs simplicity.....*

# Wireless Crew Communication Project



## WCC Loops #1

These diagrams illustrate different possibilities for communication configurations from the space station to ground, via the ATU. They were used to help communicate ideas between the differing diagram formats used by Human Factors designers, and Electrical Engineers on the WCC team, and were updated and modified weekly to better mesh the two different styles of representation.

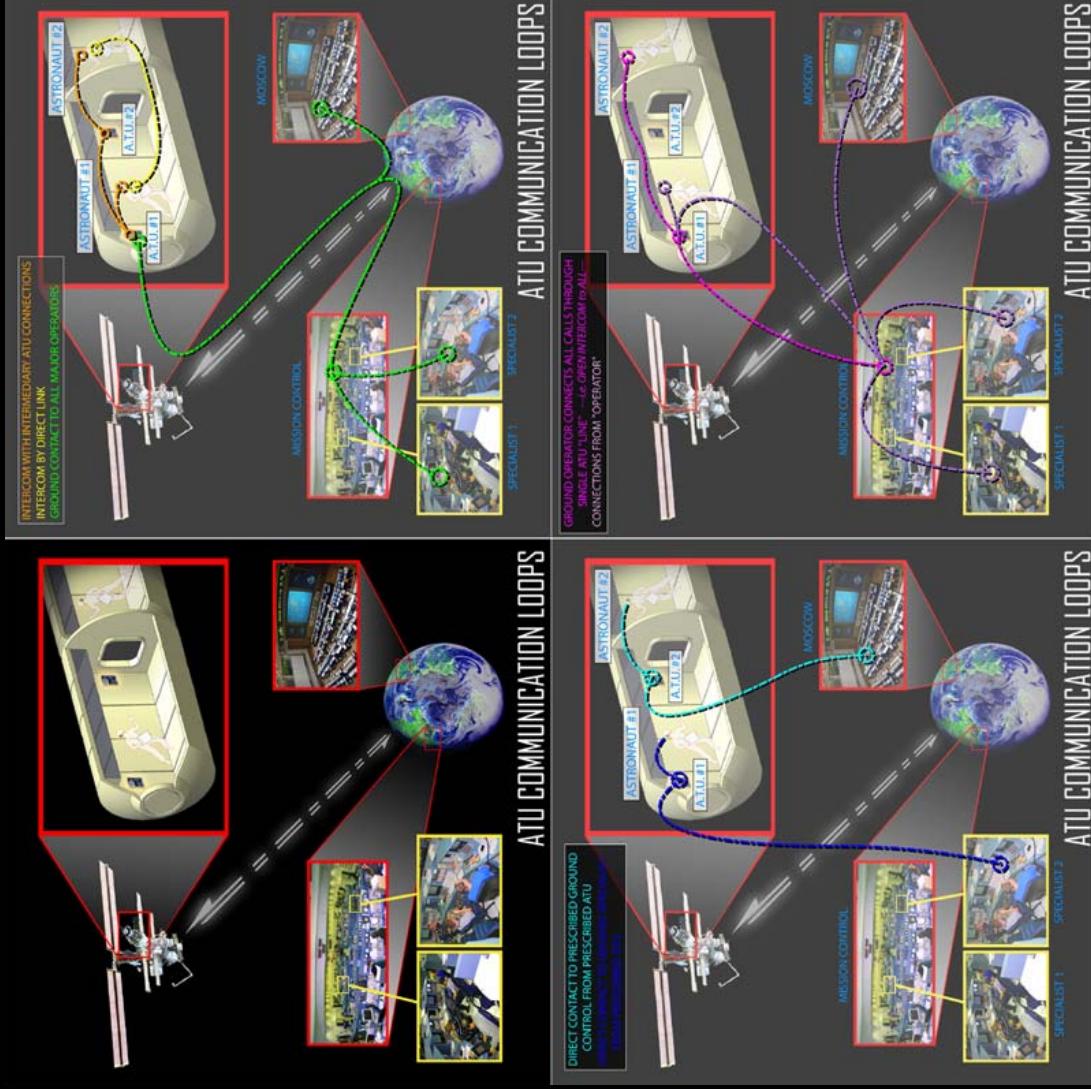



# Wireless Crew Communication Project

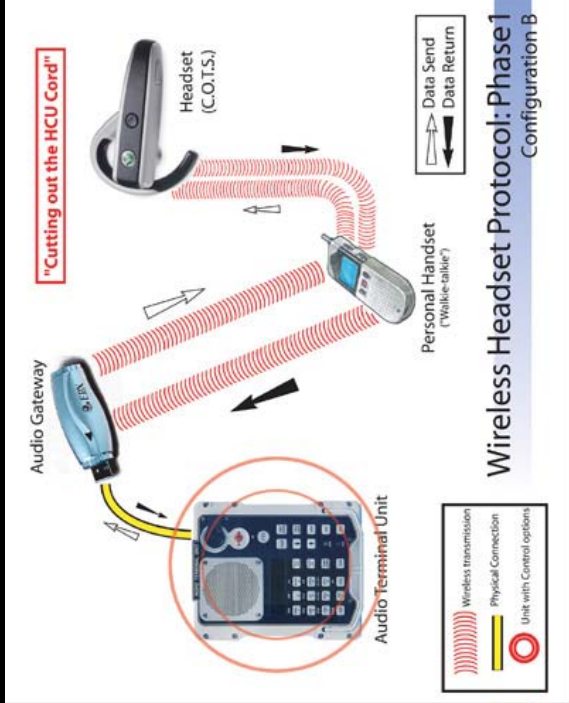

Wireless Headset Protocol: Phase 1 Configuration B

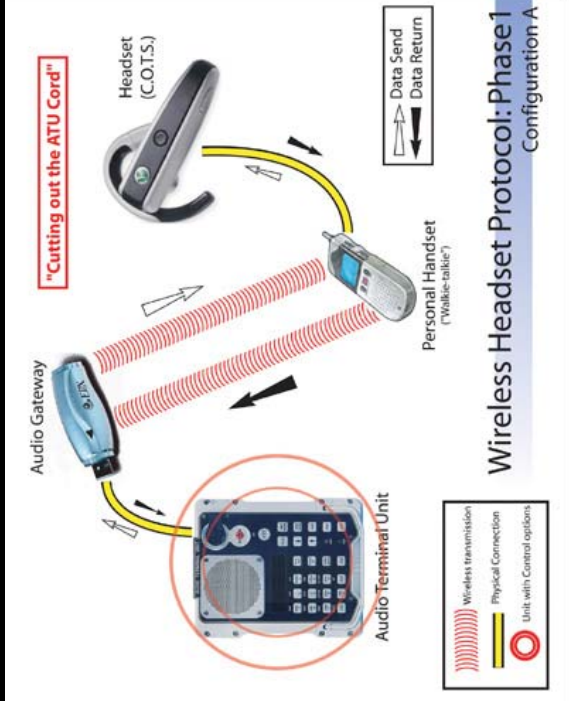

Wireless Headset Protocol: Phase 1 Configuration A

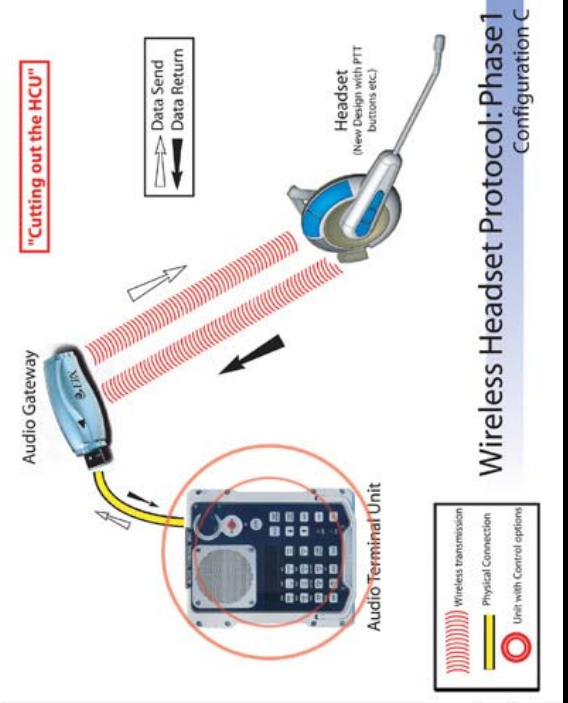

Wireless Headset Protocol: Phase 1 Configuration C

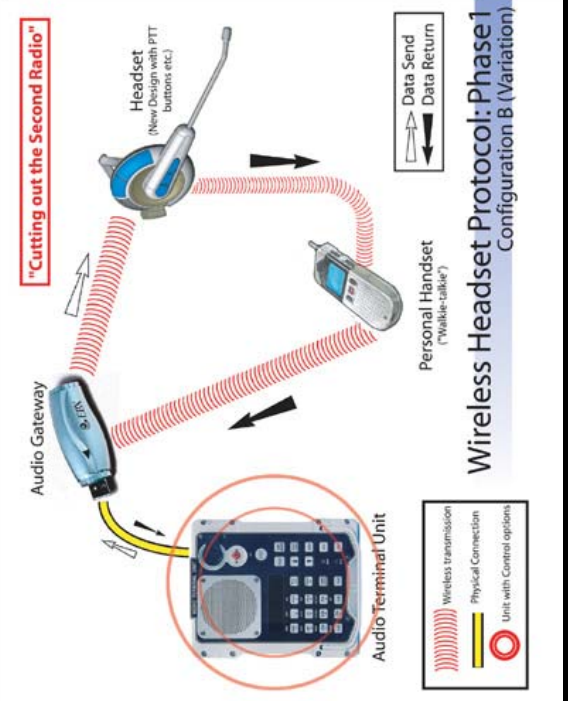

Wireless Headset Protocol: Phase 1 Configuration B (Variation)

# Wireless Crew Communication Project

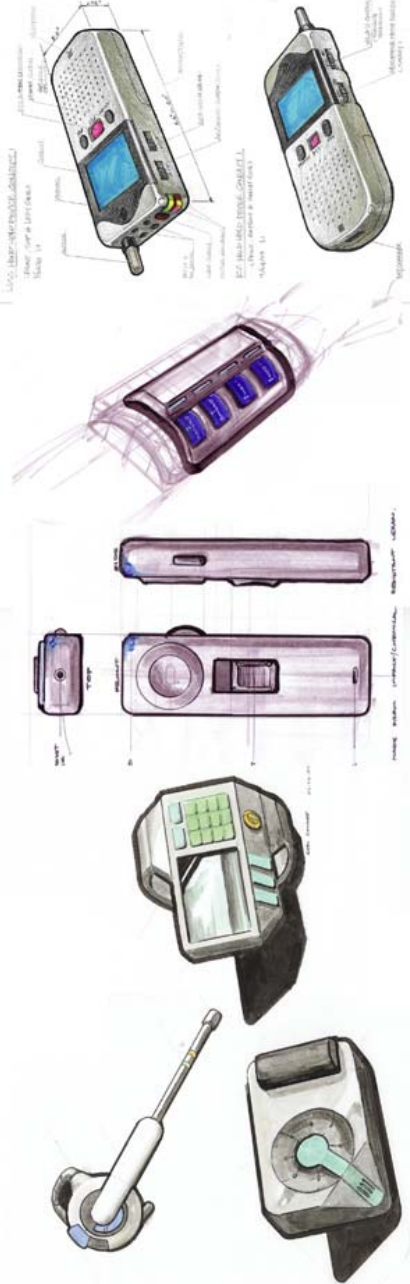

## Precedent Imagery #1

Our work on WCC Started with study of the research and concept development that our RISD colleagues had already put together, as well as the work of Mr. Li Hua of NASA and the research on available commercial wireless headsets done by NASA's UTAF Lab. This work provided a foundation for our designs.

Precedent Imagery on Wireless COM Project (J. Flaherty, L. Hua, C. Conlee)

*And using Earth “analog” to help us understand living in isolation/confinement and how the analog affects the designs.....*

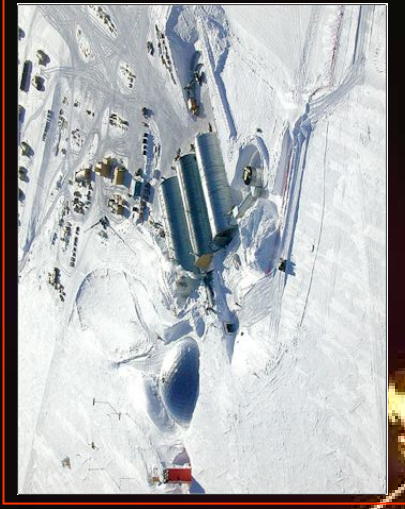

*And to continue to use the world-class laboratory – ISS – to improve upon the design of hardware and systems.....*

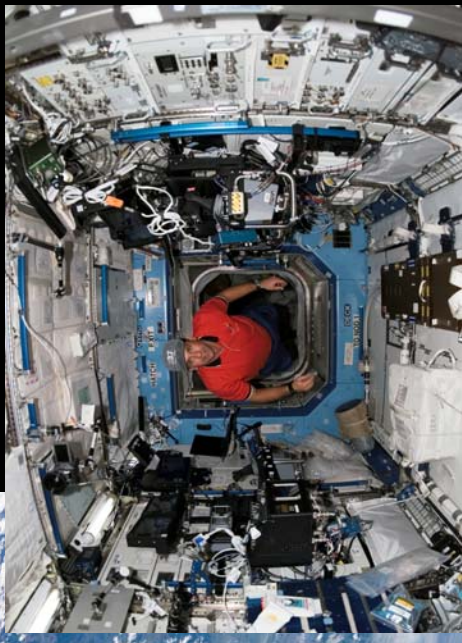

*For the next journeys to the Moon.....*





*To Mars.....and beyond.....*

