

NASA/CR—2007-214682

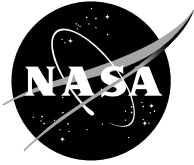

Hydrogen Generation Through Renewable Energy Sources at the NASA Glenn Research Center

*Anthony Colozza and Kevin Prokopius
Analex Corporation, Brook Park, Ohio*

April 2007

NASA STI Program . . . in Profile

Since its founding, NASA has been dedicated to the advancement of aeronautics and space science. The NASA Scientific and Technical Information (STI) program plays a key part in helping NASA maintain this important role.

The NASA STI Program operates under the auspices of the Agency Chief Information Officer. It collects, organizes, provides for archiving, and disseminates NASA's STI. The NASA STI program provides access to the NASA Aeronautics and Space Database and its public interface, the NASA Technical Reports Server, thus providing one of the largest collections of aeronautical and space science STI in the world. Results are published in both non-NASA channels and by NASA in the NASA STI Report Series, which includes the following report types:

- **TECHNICAL PUBLICATION.** Reports of completed research or a major significant phase of research that present the results of NASA programs and include extensive data or theoretical analysis. Includes compilations of significant scientific and technical data and information deemed to be of continuing reference value. NASA counterpart of peer-reviewed formal professional papers but has less stringent limitations on manuscript length and extent of graphic presentations.
- **TECHNICAL MEMORANDUM.** Scientific and technical findings that are preliminary or of specialized interest, e.g., quick release reports, working papers, and bibliographies that contain minimal annotation. Does not contain extensive analysis.
- **CONTRACTOR REPORT.** Scientific and technical findings by NASA-sponsored contractors and grantees.

- **CONFERENCE PUBLICATION.** Collected papers from scientific and technical conferences, symposia, seminars, or other meetings sponsored or cosponsored by NASA.
- **SPECIAL PUBLICATION.** Scientific, technical, or historical information from NASA programs, projects, and missions, often concerned with subjects having substantial public interest.
- **TECHNICAL TRANSLATION.** English-language translations of foreign scientific and technical material pertinent to NASA's mission.

Specialized services also include creating custom thesauri, building customized databases, organizing and publishing research results.

For more information about the NASA STI program, see the following:

- Access the NASA STI program home page at <http://www.sti.nasa.gov>
- E-mail your question via the Internet to help@sti.nasa.gov
- Fax your question to the NASA STI Help Desk at 301-621-0134
- Telephone the NASA STI Help Desk at 301-621-0390
- Write to:
NASA Center for AeroSpace Information (CASI)
7115 Standard Drive
Hanover, MD 21076-1320

NASA/CR—2007-214682

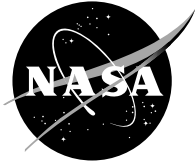

Hydrogen Generation Through Renewable Energy Sources at the NASA Glenn Research Center

*Anthony Colozza and Kevin Prokopius
Analex Corporation, Brook Park, Ohio*

Prepared under Contract NAS302150–100

National Aeronautics and
Space Administration

Glenn Research Center
Cleveland, Ohio 44135

April 2007

Trade names and trademarks are used in this report for identification only. Their usage does not constitute an official endorsement, either expressed or implied, by the National Aeronautics and Space Administration.

Level of Review: This material has been technically reviewed by NASA expert reviewer(s).

Available from

NASA Center for Aerospace Information
7115 Standard Drive
Hanover, MD 21076-1320

National Technical Information Service
5285 Port Royal Road
Springfield, VA 22161

Available electronically at <http://gltrs.grc.nasa.gov>

Hydrogen Generation Through Renewable Energy Sources at the NASA Glenn Research Center

Anthony Colozza and Kevin Prokopius
Analex Corporation
Brook Park, Ohio 44142

Abstract

An evaluation of the potential for generating high pressure, high purity hydrogen at the NASA Glenn Research Center (GRC) was performed. This evaluation was based on producing hydrogen utilizing a prototype Hamilton Standard electrolyzer that is capable of producing hydrogen at 3000 psi. The present state of the electrolyzer system was determined to identify the refurbishment requirements. The power for operating the electrolyzer would be produced through renewable power sources. Both wind and solar were considered in the analysis. The solar power production capability was based on the existing solar array field located at NASA GRC. The refurbishment and upgrade potential of the array field was determined and the array output was analyzed with various levels of upgrades throughout the year. The total available monthly and yearly energy from the array was determined. A wind turbine was also sized for operation. This sizing evaluated the wind potential at the site and produced an operational design point for the wind turbine. Commercially available wind turbines were evaluated to determine their applicability to this site. The system installation and power integration were also addressed. This included items such as housing the electrolyzer, power management, water supply, gas storage, cooling and hydrogen dispensing.

1. Introduction: Hydrogen Generation Station

The ability to generate high pressure, high purity hydrogen at NASA GRC would provide a unique capability for GRC and could potentially be utilized both on the center and by the surrounding community. This could be accomplished through the refurbishment and installation of the Hamilton Standard electrolyzer presently being stored at GRC. Because of the high pressure/high purity hydrogen production capability, the electrolyzer could be utilized to generate fuel for hydrogen powered vehicles (both fuel cell powered or combustion engine powered). This electrolyzer, in conjunction with renewable power generation, would act as a model hydrogen source and as part of an initial fueling station for hydrogen powered vehicles in the northern Ohio region.

The Hamilton Standard Sea Wolf submarine prototype electrolyzer is presently being stored at GRC. This Oxygen Generating Plant (OGP) (ref. 1) is a prototype electrolyzer system manufactured by General Electric under contract to the United States Navy in 1982 to provide a continuous supply of oxygen to the passengers onboard the Navy's Sea Wolf submarine. The OGP accumulated around 10,000 hr of run time on the submarine, operating at pressures ranging between 300 and 3000 psi. Hamilton Standard refurbished the system in 1993 for operation at a renewably powered hydrogen generation test-bed located at Edwards Air Force base and operated by the Jet Propulsion Laboratory. The OGP features include the fluid system, the control system, which is now an Allen Bradley programmable controller, and the power supply, which is controlled by the Allen Bradley unit.

This electrolyzer is a unique piece of hardware. NASA originally utilized it as part of a renewable power test bed located at the Edwards Air Force base in California. Once that project was completed, in the mid 1990's, the electrolyzer was placed into storage and then in 2002 returned to NASA GRC.

This electrolyzer has a number of unique capabilities that would enable it to be utilized for both hydrogen production for lab use as well as hydrogen production for fueling a fuel cell or hydrogen combustion powered vehicle. The electrolyzer stack has a design operational life of 75,000 hr. The stack utilizes the Polymer Electrolyte Membrane (PEM) technology to electrolyze distilled water into hydrogen

and oxygen gas. It is capable of producing oxygen gas at a continuous rate of 150 scfh and hydrogen gas at a rate of 300 scfh over the 300 to 3000 psi range. The unit can be operated remotely or with personnel present. This is dictated by the operating pressure, with pressures beyond 750 psi requiring remote means of operation.

The capability to produce very pure hydrogen at a high rate would enable it to be utilized as a source for vehicle refueling. Also the high-pressure output would reduce the amount of additional compression to raise the gas to a higher pressure that would be needed for a fueling system. This is a significant system efficiency advantage over commercially available low-pressure PEM electrolyzers.

To make the production of hydrogen as a vehicle fuel environmentally viable it needs to be produced through a renewable source of power. Utilizing fossil fuels to produce hydrogen to be utilized in a vehicle as fuel is less efficient and more polluting than just using the fossil fuels directly in the vehicle. Therefore the goal of this hydrogen production system would be to utilize renewable power as the source for generating hydrogen and thereby producing a truly clean source of fuel. The renewable power sources selected for this analysis were solar photovoltaic cells and wind power. NASA GRC has an available solar array field that could be utilized for this project. With some upgrades, the array field could supply the majority of the energy needs of the electrolyzer throughout the year.

Since it has been in storage for nearly a decade, one goal of the project is to evaluate the present state of the OGP. Inspecting the hardware, gaining access to the electrolyzer cell stack and filling it with water are the first steps in accomplishing this task. The water will re-hydrate the stack membranes as well as act as an initial indication of the integrity of the seals between the stack cells. If the stack can hold water the next step is to pressurize the stack with nitrogen to ensure there are no smaller leaks within any of the cell seals or membranes that would have not been detected by filling the stack with water. In addition to evaluating the present state of the OGM, other commercially available electrolyzers were identified as possible substitutes for generating hydrogen.

The production of hydrogen, as a fuel for lab and vehicle use, requires a system design encompassing the hydrogen generation, storage, power production, energy storage and installation of the various hardware components. The implementation of this type of clean environmentally friendly source of hydrogen is a step on the path toward reducing or eliminating our dependence on oil as a main source of transportation fuel.

2. Hydrogen Generator

Hamilton Standard: Sea Wolf Prototype Electrolyzer

The Oxygen Generating Plant (OGP) electrolyzes distilled water using ac power to produce hydrogen and oxygen gas at pressures ranging between 300 and 3000 psi. The electrolysis module consists of one, solid polymer electrolyte cell stack. The stack is comprised of 83 cells in series with a maximum current rating of 250 A and a maximum voltage across the entire stack of 249 V. Table 2.1 provides the OGP cabinet dimensions including its approximate weight along with the OGP dimensions on the dolly. Figures 2.1 through 2.3 provide overall views of the OGP, with figure 2.3 focusing in on the pressure vessel that houses the electrolyzer stack (ref. 1).

TABLE 2.1.—OGP DIMENSIONS
AND APPROXIMATE WEIGHT

Characteristic	Value
Height (in.)	72
Width (in.)	56
Depth (in.)	40
Weight (lb)	8,000



Figure 2.1.—OGP front view.

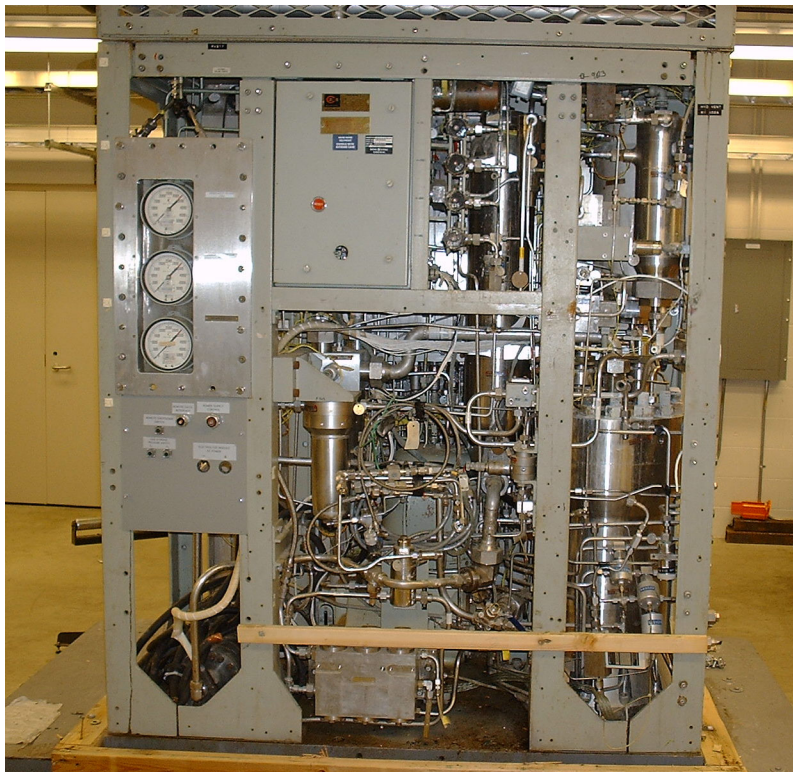

Figure 2.2.—OGP back view.

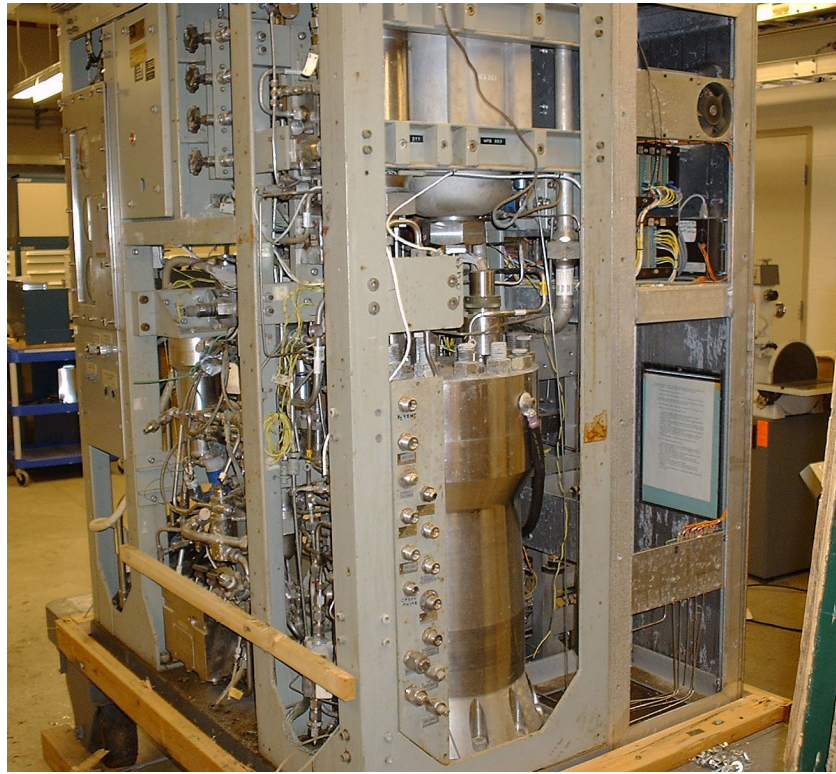

Figure 2.3.—OGP side view showing Electrolyzer Pressure Vessel.

Power Requirements

The required electrical power input is 440 Vac, 60 Hz, 3 phase which feeds the power supply, 115 Vac instrumentation, and control circuits. The instrumentation and control circuits are powered via a transformer within the 440 Vac circuit breaker module while the power supply is fed directly from the output of the 440 Vac circuit breaker. The power supply generates heat when converting the 440 Vac line voltage to the direct current and voltage requirements of the electrolyzer stack. A mixture of 35 percent ethylene glycol/65 percent distilled water is required for cooling the power supply to a maximum temperature of 85 °F. Table 2.2 provides the dimensions for the power supply and Figure 2.4 shows the overall view of the unit (ref. 1).

TABLE 2.2.—POWER SUPPLY DIMENSIONS

	Cabinet	With control panel
Height (in.)	69	69
Width (in.)	29	36
Depth (in.)	28	28



Figure 2.4.—Overall view of the power supply.

Electrolyzer Stack Operational Water Requirements

The distilled feed water supply to the stack needs to be provided at a specific pressure, temperature, and purity level to meet the unit's operational requirements. The normal supply pressure is 25 psig and must be maintained between 10 and 100 psig throughout operation. The temperature of the water should be maintained between 60 and 110 °F, with 70 °F as the recommended operational point. The water resistivity needs to be greater than 10 MΩ-cm and has to be filtered to at least 100 μm. The water's pH needs to be between 5.6 and 8.0 and have no oil or suspended solids. Continuous maximum water input flow to the electrolyzer stack is 3.5 gph (ref. 1).

Electrolyzer Stack Cooling Water Requirements

The stack is cooled directly by circulating feed water through at a rate that approaches 100 times the water electrolysis rate. Heat is removed from the feed water by passing it through a shell and tube heat exchanger mounted at the top of the OGP. The chilled ethylene glycol/distilled water cooling mixture has a minimum flow rate of 2.5 gpm at a temperature of 55 °F which will result in the OGP producing 75 °F hydrogen and oxygen gas at the maximum generation rate. The chilled cooling mixture maximum supply pressure is 100 psig (ref. 1).

OGP Inert Gas Requirements

The OGP requires oil free nitrogen for pressure control of the dome-loaded regulators and for blanket pressurization of the electrolysis module pressure vessel. The nitrogen supply pressure is regulated to 50 psi above the oxygen pressure and 50 to 100 psi above the hydrogen pressure. This results in a maximum nitrogen pressure of 3050 psig at the maximum oxygen pressure of 3000 psig. The initial

fill of the system at startup is 115 scf nitrogen and a small 5 scfh nitrogen flow is maintained throughout its operation to purge the pressure vessel (ref. 1).

Present State

The first step in determining the present state of the electrolyzer stack was performed by hydrating the stack with deionized water. Before introducing any water, the nitrogen purge line was opened and a small quantity of water was seen to flow out the line. The line was opened at a valve not seen on the fluid schematic for the OGP. Its location was downstream of valve V410 shown in figure 2.5. Initial indications were positive since the water in the line indicates that the stack may still be partially hydrated. The line was then closed off along with nitrogen bleed through valve V410 and valve V411 which supplied nitrogen to the differential back pressure regulator DBPR306 on the hydrogen product line.

The main water supply line to the electrolyzer stack was then opened and roughly 0.5 gal of deionized water was fed to the stack on December 20, 2005. The supply line was secured back in place and the stack was allowed to sit overnight with the water level up to the inlet flange leading into the pressure vessel.

Three days later (Dec. 23, 2005), the water level was checked and was confirmed to be at the same original location in the supply line. The nitrogen purge line was opened again at the valve downstream of V410 and a small quantity of water again flowed out the line. The water level did not change when the purge line valve was opened. The supply line was secured back in its original location.

Almost 2 weeks later, on January 4, 2006, the water level was checked and confirmed to be at the same location as seen on December 23, 2005.

On January 12, 2006, the nitrogen line located at the bottom of the stack vessel was opened and there was no flow of water seen from this point in the system. The water level remained the same in the fill line to the stack, indicating no flow of water from the stack to the vessel chamber.

About 3 weeks later, on February 1, 2006, the water level was seen to have dropped below the point where it had been since it was last checked. Around 50 mL of deionized water was added to bring the level up to the inlet flange leading into the pressure vessel. It was deduced that the membranes were soaking up a portion of the water and over time had become completely hydrated, passing the water into the hydrogen side of the fuel cell.

Further testing indicated that water was leaking from the stack seals into the pressure vessel. This conclusion was reached through the addition and monitoring of deionized water to the stack. The sequence of the events leading to this conclusion are as follows:

- On February 13, 2006, an additional 20 mL of deionized water was added to the pressure vessel.
- Two days later (Feb. 15, 2006), 7 more milliliters of deionized water were added.
- On February 23, 2006, the nitrogen purge line was opened at the union nut directly off the pressure vessel. Approximately 10 to 15 mL of water came out at this point. The level in the distilled water supply line did not drop. However, there was no water present in the hydrogen outlet port at the top of the pressure vessel.
- Roughly 10 to 15 mL of water was added to the hydrogen outlet port on February 23, 2006.

Upon closer examination, there was an observed flow of water, about 1 drop every 25 sec, coming from the bottom nitrogen port connection to the pressure vessel. The water level in the hydrogen out port appeared to be slowly falling as well. This occurrence indicated the flow of water from the stack into the pressure vessel through the stack seals was likely. This was not observed before since the hydrogen out port had not been disconnected from the top of the pressure vessel.

From this point forward to the present day of May 1, 2006, an additional 340 mL of deionized water had to be added to bring the level up to the top supply flange.

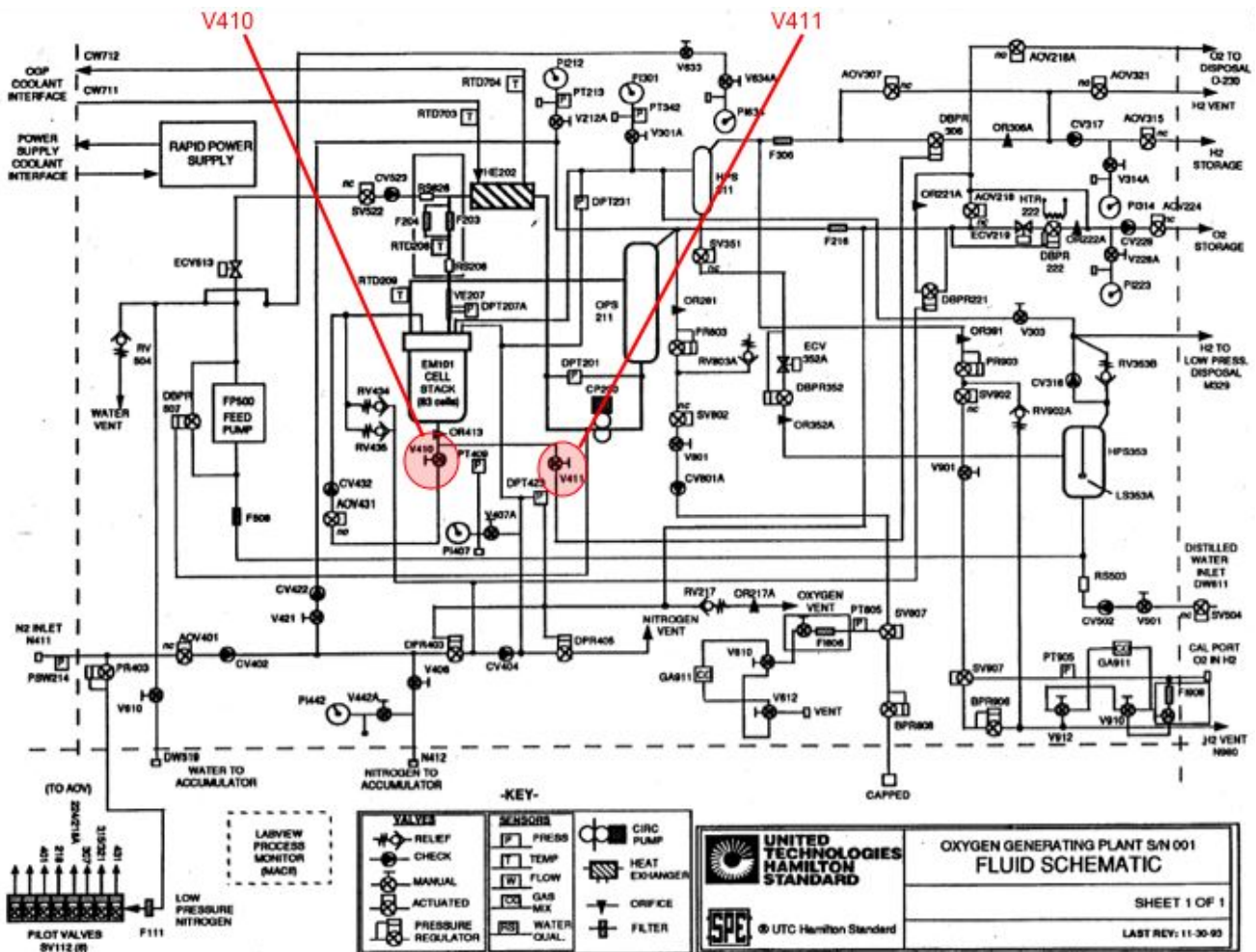

Figure 2.5—OGP fluid schematic.

Checkout of the stack over the past 4½ months confirmed the stack’s membranes to be completely hydrated along with significant water leakage from the stack to the pressure chamber. The volume of water added to the stack over time greatly exceeds any amount lost due to evaporation. This indicates that the stack is leaking water into the surrounding containment vessel. The next step would have been to pressure test the stack with nitrogen. However, based on the water leakage rate observed over the past months it was deemed unnecessary to perform the nitrogen pressure test. This test could still potentially be performed at a later date to further verify the stack condition and or the extent of the leakage. It is recommended that the nitrogen pressure testing be performed prior to any refurbishment in order to gauge the severity of the stack leakage.

Refurbishment Requirements

Upon uncrating the electrolyzer, there were several noteworthy observations made concerning the unit’s overall condition. First, there were a number of process lines that were open to atmosphere or completely separated from the rest of the system. This will require the system to be cleaned for oxygen service where necessary and to be assembled back together to its original, refurbished condition. Figures 2.6 through 2.8 show the OGP’s condition with process lines and components not connected to the system.

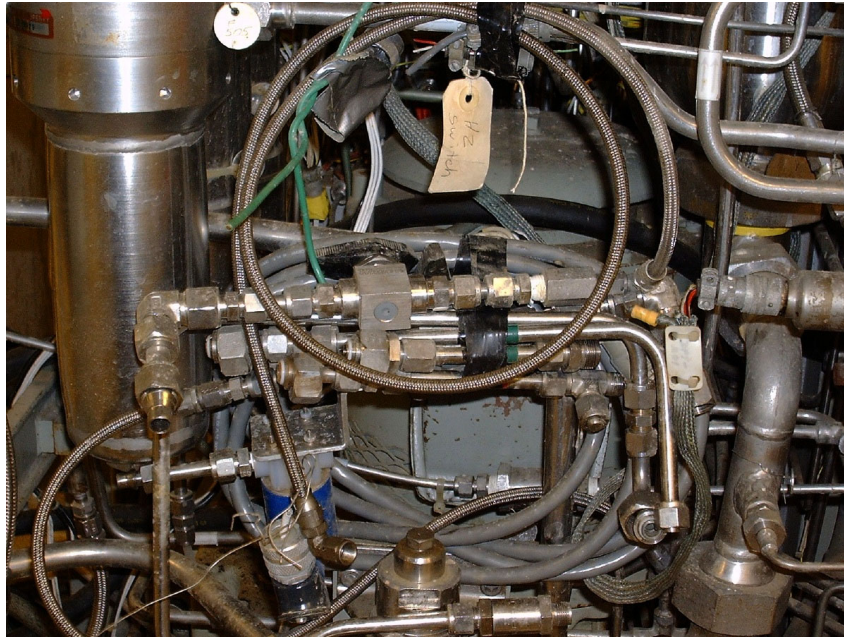

Figure 2.6.—Loose OGP process lines.



Figure 2.7.—Unconnected process lines in front of the electrolyzer stack pressure vessel.

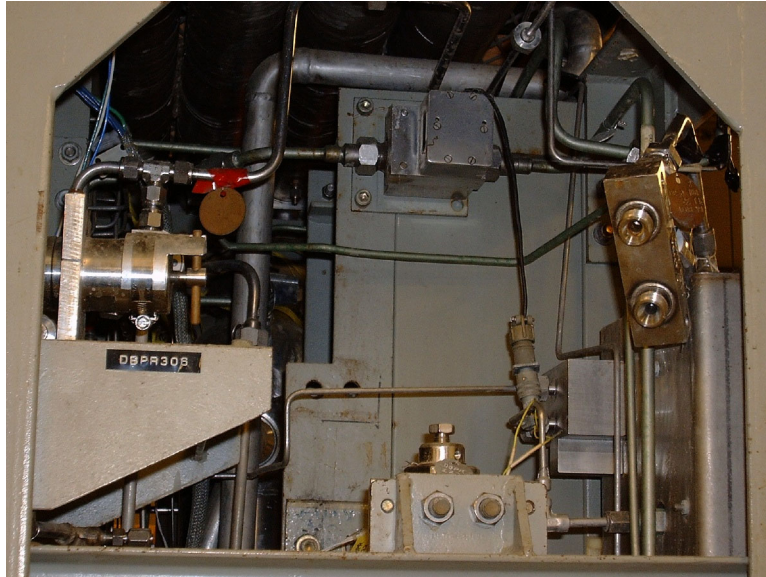

Figure 2.8.—Unattached oxygen vent manifold.



Figure 2.9.—Electrolyzer stack power cables and data acquisition cable bundle.

Figures 2.9 and 2.10 depict the condition of the electrical subsystem. Figure 2.9 shows the cables used for supplying electrical power to the electrolyzer stack as well as the loose yellow colored wire bundle for data acquisition. Figure 2.10 show the cables cut for the control system. Labor hours would be required for installation and confirming the functionality of all electrical wiring.

Figure 2.11 shows an oily type residue residing on the base of the OGP. Cleanup of the unit would need to be performed as part of the refurbishment process.

Based on the noted observations, the cost for refurbishing the OGP would be about \$400,000. This cost would cover labor hours as well as required mechanical and electrical hardware purchases. Because this is a unique, not commercially available electrolyzer, it is somewhat difficult to compare this refurbishment cost to the actual cost of the electrolyzer.



Figure 2.10.—OGP control system interface panel.



Figure 2.11.—Base of the OGP next to the distilled water feed pump.

3. Electrolyzer Options

Commercial or near commercial electrolyzers are now available and can be used as an option to refurbishing and utilizing the Hamilton Standard electrolyzer, described in section 2. A number of these electrolyzers exist but the majority of them are prototype noncommercial units. A brief description of these available options is given below. Where possible the unit cost is included as well as the present state of commercialization.

Avalence Hydrofiller

Avalence LLC has a line of hydrogen generators that can produce from 15 scfh (0.42 m³/hr) to 175 scfh (5 m³/hr) of hydrogen at a pressure of up to 10,000 psi (690 bar). The process utilizes electrolysis with a simple fluid electrolyte and is capable of achieving this high-pressure hydrogen production without the need for a compressor. The hydrogen purity is approximately 99.6 percent pure (ref. 2). The Hydrofiller 50 unit is shown in figure 3.1.

This electrolyzer is capable of producing comparable rates of hydrogen at higher output pressures. The only concern for use in fuel cells is the relatively low hydrogen purity. Typically, fuel cell hydrogen purity requirements are very high, at least 99.9 percent. Utilizing lower purity hydrogen could potentially damage the fuel cell causing it to fail. This electrolyzer is presently a prototype system still under development by the manufacturer. Therefore the price for this electrolyzer is not available.

Hydrogenics HyLYZER Electrolyzer System

Hydrogenics Corporation produces commercial electrolyzers with a hydrogen generation capacity of between 40 scfh (1.13 m³/hr) and 1000 scfh (28.3 m³/hr) at 100 psi (7 bar) pressure. The Hydrogenics HyLYZER electrolyzer series has three different unit sizes, HyLYZER 2.5, 20, shown in figure 3.2, and 65. These are named based on the amount of hydrogen, in kilograms; they are capable of producing in a 24-hr period. Their low output pressure would require the use of a compression system for compressing the hydrogen up to higher pressures for storage (ref. 3). The available information from Hydrogenics about this electrolyzer indicates that it is commercially available as both a stand-alone unit and integrated into a complete hydrogen fueling station. However, no pricing information was available.



Figure 3.1.—Avalence High Pressure Hydrogen Generator (ref. 2).



Figure 3.2.—Hydrogenics HyLYZER Hydrogen Generation Electrolyzer.

Linde Hydross Electrolyzer System

Linde manufactures a series of hydrogen generation plants based on water electrolysis. These plants are capable of producing hydrogen at a rate of between 180 scfh (5 m³/hr) and 9000 scfh (254 m³/hr) at pressures up to 370 psi (25 bar). This low output pressure would require a compression system to increase the hydrogen pressure for storage (ref. 4). The available information from Linde about this electrolyzer indicates that it is commercially available as both a stand-alone unit and integrated into a complete hydrogen fueling station. However, no pricing information was available.

Hydro HEP Electrolyzer System

Norsk Hydro offers a series of electrolyzers with output capacity between 10 and 65 m³/h (355 and 2300 scfh). The output pressure is 15 bar (363 psi). As with the previous electrolyzers a compression system will be needed to bring the output pressure up to that required for storage (ref. 5). The available information from Norsk Hydro about this electrolyzer indicates that it is commercially available as both a stand-alone unit and is presently being integrated into a complete prototype hydrogen fueling station. However, no pricing information was available.

Proton Energy HOGEN Electrolyzer System

Proton Energy Systems produces two lines of electrolyzers, the HOGEN S and H series. The HOGEN S series can produce hydrogen at a rate of 20 or 40 scfh (0.53 or 1.05 m³/hr) at an output pressure of 200 psi (13.8 bar). The HOGEN H series are larger units with outputs between 76 and 228 scfh (2 to 6 m³/hr) at an output pressure of 218 psi (15 bar). This series unit is shown in figure 3.3. The purity rate for both series is very high 99.9995 percent and would be applicable to fuel cell operation (ref. 6). Presently a HOGEN 40 (S series) is in storage at NASA Glenn and would be available for use. The available information from Proton Energy Systems about this electrolyzer indicates that it is commercially available as both a stand-alone unit and integrated into a complete hydrogen fueling station in partnership with Air Product Inc. However, no pricing information was available.



Figure 3.3.—Proton HOGEN H-Series Electrolyzer Unit.



TELEDYNE HM Series >>>

Figure 3.4.—Teledyne TITAN HM Series Electrolyzer.

Teledyne TITAN Electrolyzer System

The Teledyne TITAN series of electrolyzers can produce hydrogen at a rate of up to 5297 scfh (150 m³/hr) at a pressure of 115 psi (8 bar). The purity of the output gas is very high, 99.9998 percent, making it applicable for use with a fuel cell. The Teledyne HM series unit is shown in figure 3.4 (ref. 7). A compression system would be needed to provide the higher pressure required for storage. The available information from Teledyne about this electrolyzer indicates that it is commercially available. However, no pricing information was available.

Treadwell Corporation PEM Electrolyzer System

Treadwell Corporation produces a line of electrolyzers that can produce hydrogen at a rate up to 10.2 m³/hr (360 scfh) and pressure of 1100 psi (76 bar). This higher-pressure output would reduce the amount of compression needed for storage. Although not as high an output pressure as the Hamilton-Standard unit, it still has significantly greater output pressure than the other available commercial PEM units. A picture of a Treadwell Corporation electrolyzer unit is shown in figure 3.5 (ref. 8). Based on the available information from Treadwell it is not clear if this unit is a prototype or commercially available. No pricing information was available for the unit.



Figure 3.5.—Treadwell Corporation PEM Electrolyzer Unit.

4. System Design

The electrolyzer system is designed to provide a source of hydrogen for use at the NASA GRC and to provide a refueling station for hydrogen-powered vehicles. Ideally hydrogen will be produced through renewable energy making it a truly environmentally clean source of fuel. Within the northern Ohio environment the available renewable energy sources for the hydrogen production will be solar and wind. The system will also need a form of energy storage to effectively operate as a fueling station. For this initial system design the electrical grid will act as this energy storage mechanism. Because the output of the renewable power sources is not constant and somewhat unpredictable, the grid connection would ensure that sufficient hydrogen can be produced under all weather conditions and times of the year. Also if excess power is being produced by the renewable sources, more than the hydrogen generation can accommodate, then this excess power can be channeled to the grid. A schematic of the system showing these main components is given in figure 4.1.

The two main renewable energy sources to power the electrolyzer will be a photovoltaic array and wind turbine. These sources vary greatly in the amount of output power they can generate. Both sources are highly environment driven in their output capability. Their output will continuously change throughout the day, month and year. Therefore to design a system around these sources the total energy produced must be considered. That energy must be captured when it is available to produce hydrogen, which is then stored for future use. Since these are not “on-demand” power sources to successfully utilize them in a system requires some means of energy storage. For the system being considered, the energy storage is being accomplished through the production and storage capacity of the hydrogen gas as well as the use of the electrical grid as a means of storing and recovering energy. The electrical grid can act like a buffer for the system whereby excess power can be fed to the grid and supplemental power can be drawn off of the grid if needed. By limiting the energy extracted from the grid to the amount previously transferred to the grid the system effectively remains totally renewable.

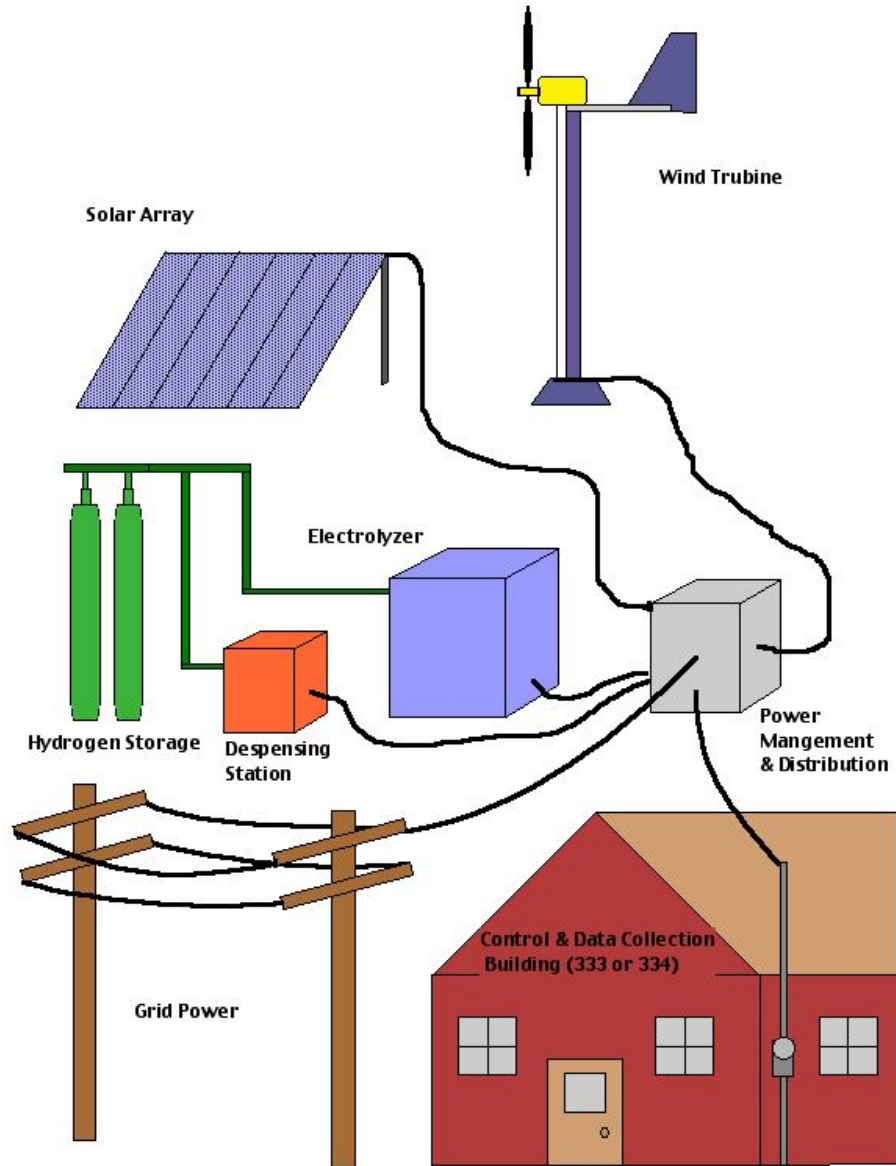

Figure 4.1.—Hydrogen Generation System Components.

Solar PV Array

An array field, shown in figure 4.2, exists at the NASA GRC. This field is located adjacent to building 333. The location of this array field, which is near the proposed site for the electrolyzer, will enable the integration and direct use of the available solar energy as a power source for the hydrogen generation station. The array field is presently partially populated with Siemens M53 array panels. The array field has the capacity to hold a total of 1729 panels. Of this total capacity 952 panels are presently installed. A diagram of the array field is given in figure 4.3. Each sub-array, as shown in figure 4.4, holds 8 array panels. The blue sub-arrays on the diagram are presently installed with M53 panels. The red sub-arrays have the support structure available but no array panels or frame for the panels is installed. The yellow sub-arrays on the diagram indicate that the mounting footers are installed but no other support structure is present and the green indicates that there is adequate space within the array field for these sub-arrays but no support footing or array structure is present.



Figure 4.2.—Present array field.

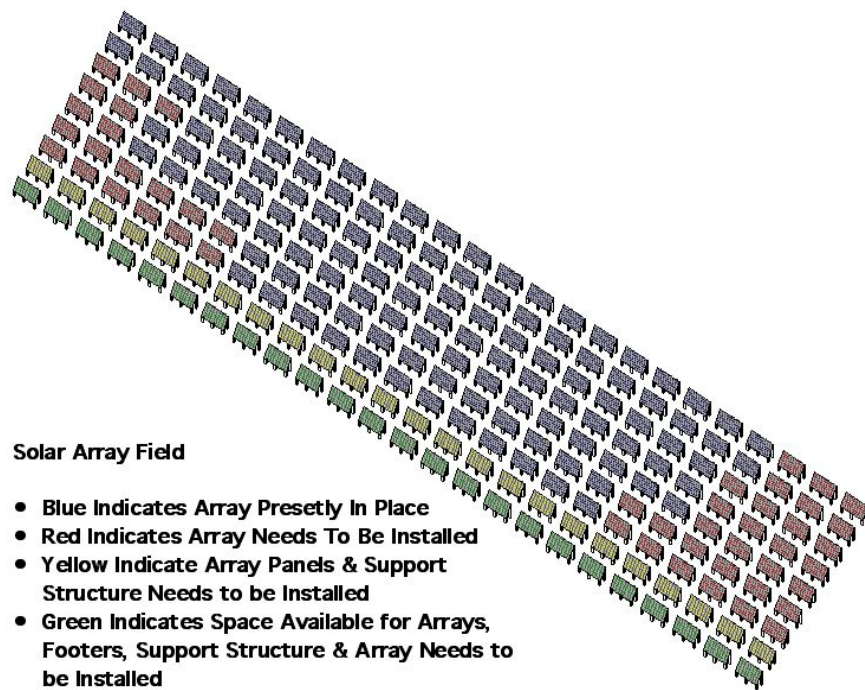

Figure 4.3.—Array field installation status.



Figure 4.4.—Eight-panel sub array in the present array field.

The photovoltaic array is used to collect sunlight and directly convert it into electricity. The amount of power produced by the solar array is dependent on a number of factors such as time of year, weather conditions and orientation of the array panel.

The following figures demonstrate how the output of the solar panel is affected by the variation in some of these quantities. Figures 4.5 through 4.7 represent the solar output from 1 square meter of array. These graphs show the effect that variation in time of year and array elevation angle have on the power output of the array. It should be noted that the array angle is measured from the horizontal, so a 0° array angle would be a horizontal array and a 90° array angle would be a vertically orientated array. The values used to generate these curves were as follows:

- 800 W/m^2 incident solar radiation
- 14.2 percent efficient solar cells
- Location Cleveland, Ohio

Higher array angles can take better advantage of the morning and evening sun, while sacrificing some of their midday performance. This can be seen in figures 4.5 and 4.6. As demonstrated in these figures the best angle to place the array at is approximately 45° facing South. For the latitude of NASA GRC this array angle will provide the most consistent output power throughout the year. Since the South facing surroundings of the array field are relatively clear of any high structures or trees there is no issue with any shadowing of the array.

Using direct and diffuse solar intensity data for the great lakes region of the US the total available daily (24 hr period) energy that can be produced by the solar array was calculated. This is shown in figure 4.8.

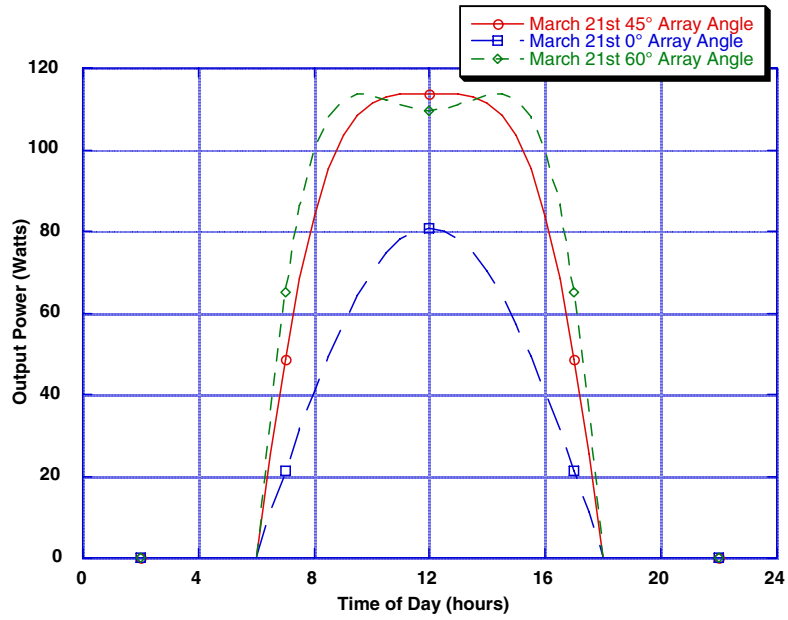

Figure 4.5.—Effect of array angle on output, March 21st.

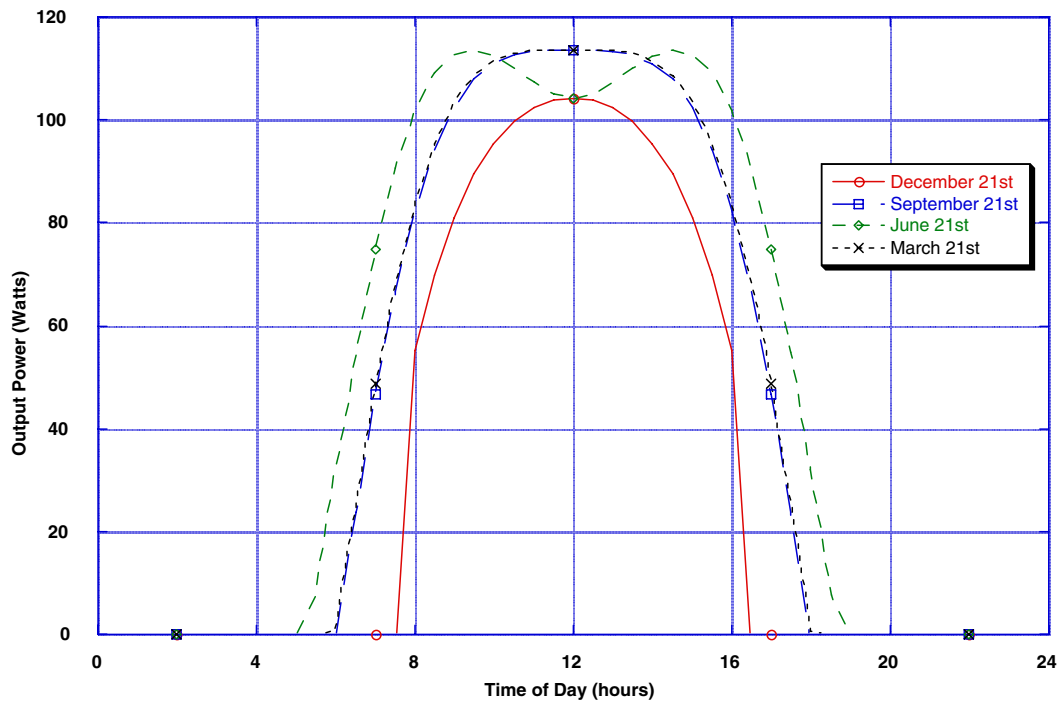

Figure 4.6.—Solar panel output for various months of the year, 45° array angle.

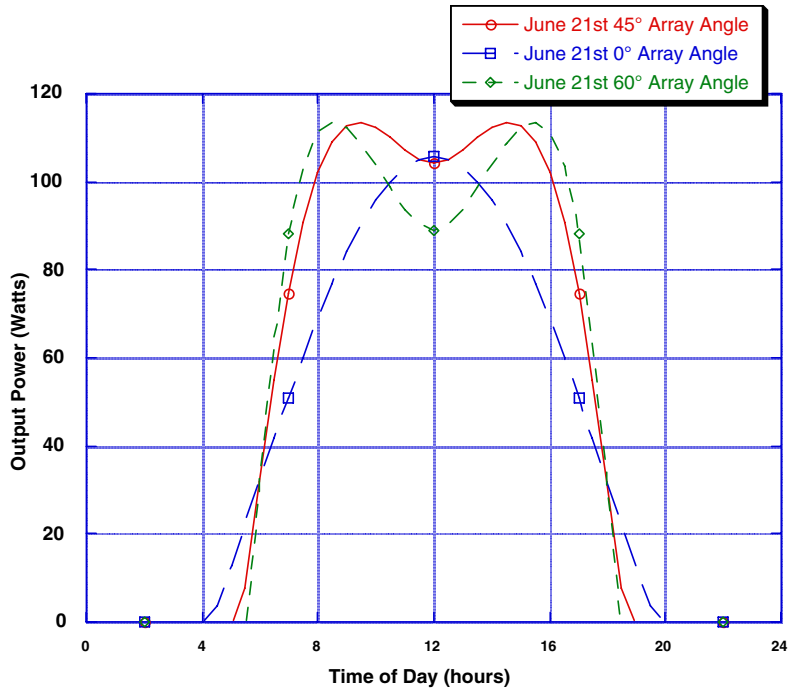

Figure 4.7.—Effect of Array Angle on Output, June 21st.

Total Available Energy Throughout the Year

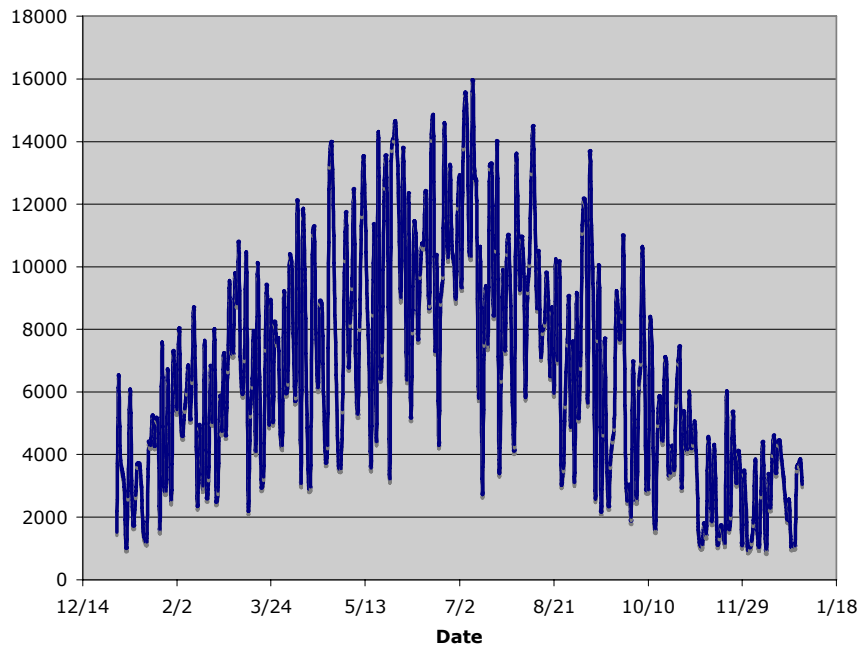

Figure 4.8.—Estimate of the daily total energy per m² Incident on the array throughout the year.

The M53 panels that are presently installed should optimally be able to produce 43 W of power at normal incidence (noon time) under standard operating conditions (25° C operating temperature and 1000 W/m² incident solar flux). Based on the number of panel presently in the array field, this translates into a maximum output power of 40.936 kW. However, the actual maximum output of the array is closer to 15 kW. This difference is due to a number of factors. First the maximum normal incidence on the array is around 800 W/m², which is well below the 1000 W/m² that the manufacturer rates them at. Second the array field needs to be refurbished. A number of the panels are probably not operating at full capacity and should be replaced. If the array panels that are presently installed were fully operational a maximum output of approximately 30 kW would be achieved.

Also as shown by the figures above the maximum achievable output power will vary with the time of day and date as well as with the environmental conditions such as temperature and cloud cover.

Since the M53 is no longer manufactured. The M55 panels can be used for upgrading the array and or fully populating the array field. The M55 has the same geometry with more efficient solar cells. Therefore it would minimize the modification needed to the array field. Figure 4.9 shows a current/voltage curve (I-V curve) for a Siemens M55 array panel. As the load demand on the solar array increases, the output voltage of the array panel will drop from a maximum of 21.7 V, in the no load or open circuit condition, to 0 V, in the short circuit condition. The voltage range of the M55 panel as well as its optimum operational output voltage of 17.4 V is the same as the M53 panels and therefore would enable the M55 panels to be easily integrated with the existing M53 panels.

In general a silicon solar cell will have a change in voltage of 2.2 mV/°C. So for the M55 panel the output voltage will change by approximately 0.079 V/°C. During the summer months, when it is warm, this will tend to degrade performance, and in the winter months, when it is colder, it will increase performance. Under extreme operating conditions this can change the array performance by up to 20 percent.

The Siemens M55 solar array panels have 36 PowerMax® solar cells. The cells are square which provides optimum cell coverage over the area of the panel. The front of the panel is covered with tempered glass, which has excellent light transmitting properties, and protects the module against most adverse environmental conditions such as hail or ice. The panel specifications are given below in Table 4.1 and a photo of the panel is shown in figure 4.10.

TABLE 4.1.—SPECIFICATIONS FOR A SIEMENS M55 SOLAR ARRAY PANEL (REF. 10)

Solar cell type	Single crystal silicon
Operating efficiency	14.2%
Short circuit current	3.35 A
Open circuit voltage	21.7 V
Maximum power current	3.05 A
Maximum power voltage	17.4 V
Solar cell area	0.4 m ²
Panel height	1.28 m (50.9 in.)
Panel width	0.33 m (13 in.)
Panel depth	0.034 m (1.3 in.)
Panel mass (weight)	5.5 kg (12 lb)

Siemens M55 I-V Curve

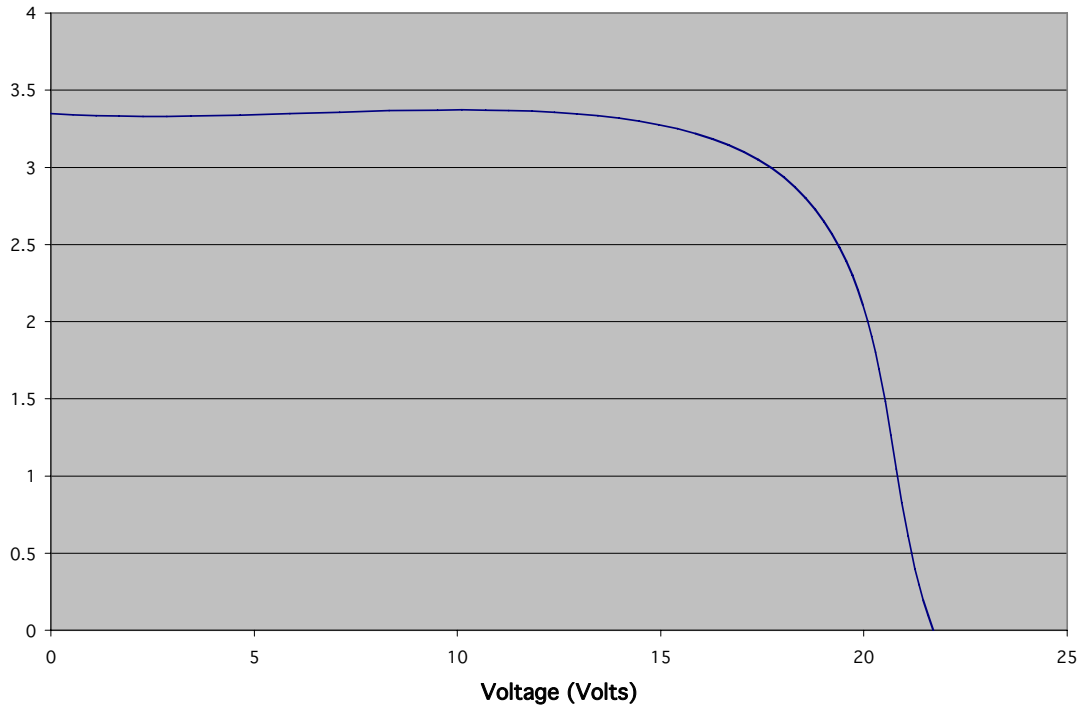

Figure 4.9.—I-V curve for a Siemens M55 Panel (ref. 9).



Figure 4.10.—Siemens M55 Solar Panel (ref. 10).

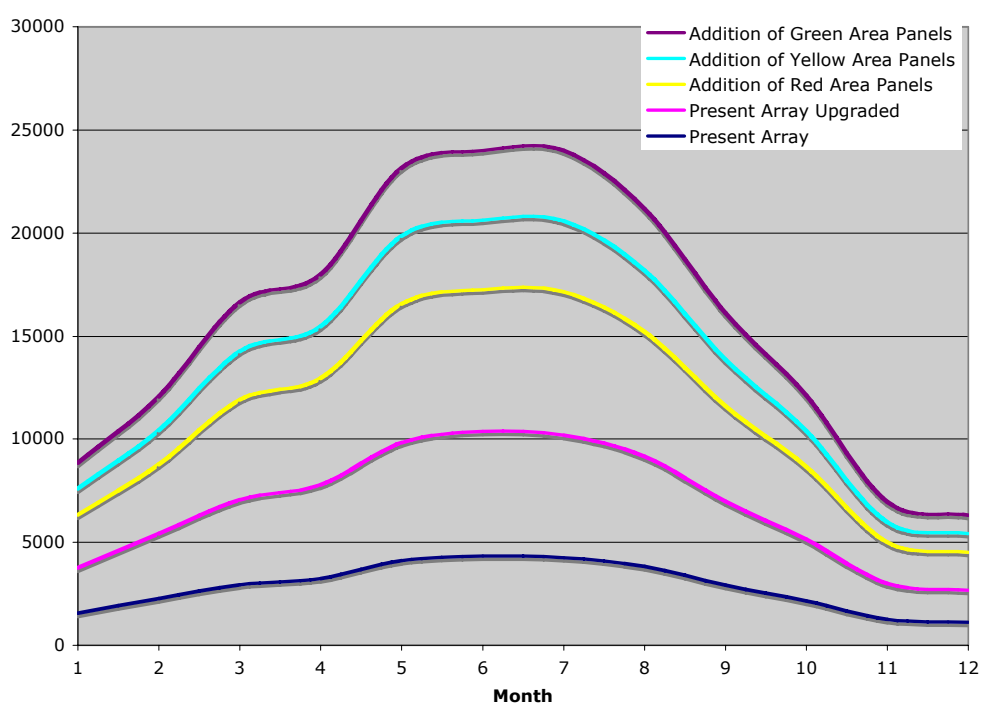

Figure 4.11.—Average array output power throughout the year for the various array upgrade options.

The average daily power output of the array throughout the year is given in figure 4.11. This figure shows the output power of the array as it presently exists as well as with the various potential upgrades as shown in figure 4.3. Since the power levels shown are for average power over the complete time period, the actual output at any given time will vary considerably from this. For example during the nighttime there will obviously be no output from the array and at noon there will be much greater output than the average given in the figure. The average power however, is a good means of comparing the impact of the various proposed improvements to the array field. Also the total energy represented by the area under the curves can be utilized to determine the total energy available. This information would be needed if an energy storage system is incorporated or if the electrolyzer is capable of operating over a range of input power levels thereby fully utilizing the output capabilities of the solar array.

The present solar array and any additions to it will be designed to operate at or near the maximum power output for the panels. As listed in table 4.1 this is approximately 17.4 V per panel. The panels are wired in series in groups of 8. This grouping constitutes a sub-array. Each sub-array will produce a maximum array output of 139 V and 2.65 A. The sub-arrays are combined in parallel to provide the total array output. The connection of the array groupings will be made in a junction box near the array field. An example of the wiring layout for the arrays is shown in figure 4.12.

Although the panels are insulated from their frames it is still a good safety precaution to provide a ground wire to all the panel frames as well as the array support structure. A continuous grounding wire can be placed on each sub-array assembly. This grounding wire will have a good electrical connection to the frames of all 8 panels on the array as well as the array structure itself. The grounding wire from each of the array assemblies will be run to a junction box from which a single grounding wire will be connected to a grounding pole or other appropriate grounding source.

A summary of the operational characteristics of the solar array is given in table 4.2 for the various installation options. Also included are the costs associated with the hardware and installation of the array panels. It should be noted that the cost estimates in table 4.2 do not include any NASA overhead. Also it is assumed that the installation would proceed sequentially from upgrading the existing array to installing the red area arrays then the yellow and finally the green. The total summed cost is a sum of the cost for all of the upgrades and installations sequentially from one stage to the next.

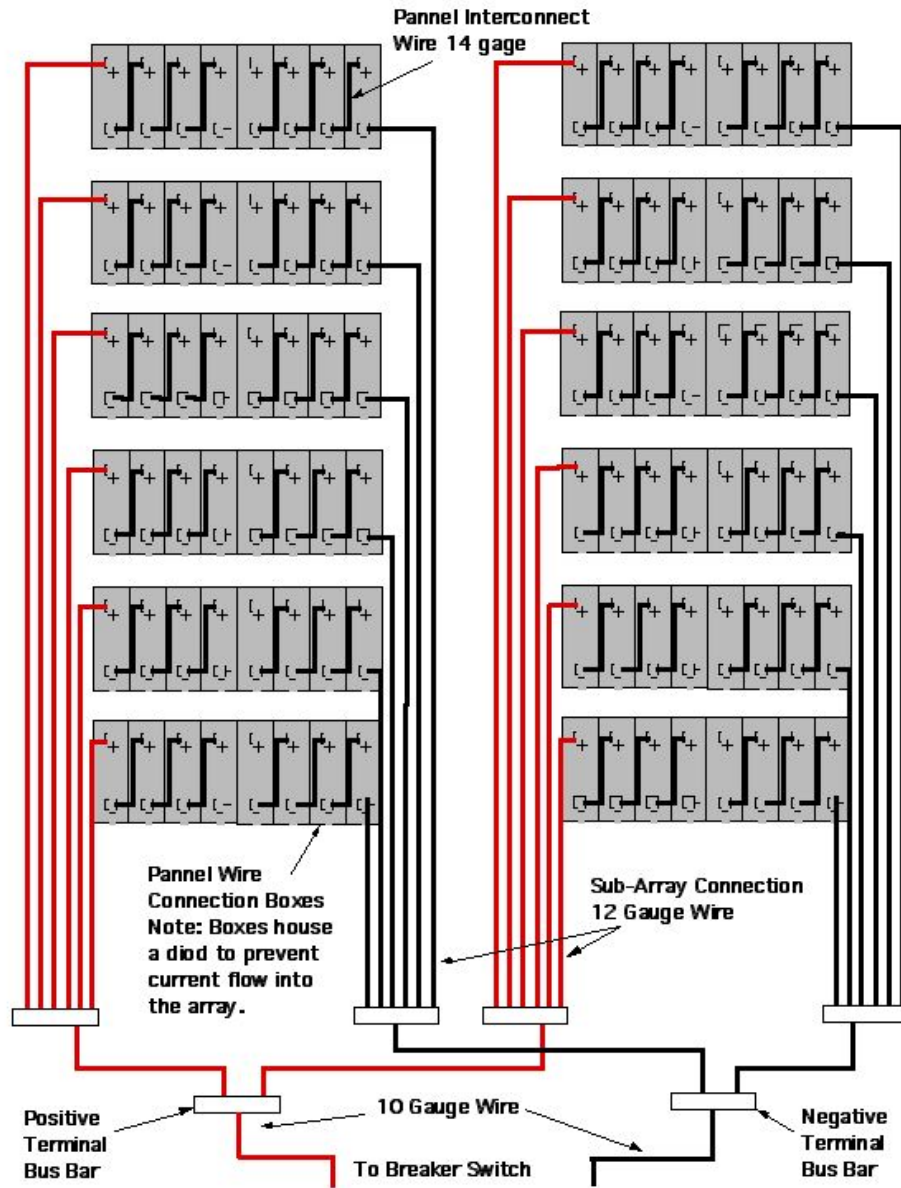

Figure 4.12.—Solar array wiring layout.

TABLE 4.2.—ARRAY INSTALLATION AND PERFORMANCE SUMMARY

Array configuration	Present configuration	Present array upgraded	Addition of red area panels	Addition of yellow area panels	Addition of green area panels
Average continuous output	2,822 W	6,773 W	11,323 W	13,551 W	15,780 W
Total yearly energy produced	90 GJ	212 GJ	360 GJ	428 GJ	497 GJ
Maximum output power	17,724 W	56,715 W	85,905 W	100,206 W	114,504 W
Hardware costs	\$0	\$90,000	\$144,200	\$74,200	\$77,200
Installation costs	\$0	\$51,848	\$51,848	\$51,848	\$51,848
Total summed cost	\$0	\$141,848	\$337,896	\$463,944	\$592,992

Upgrading the present array would include the following:

- Repairing the array structures, wiring and fuses
- Checking and replacing the array panels that are not fully functional. It is estimated that about 25 percent of the panels would need to be replaced. These would be replaced with the higher output M55 panels.
- Hardware costs which would include purchasing the array panels (approximate cost \$350 per panel plus \$7,000 for installation materials)

Adding the red area panels would include the following:

- Building and installing the array frames and support structure.
- Installing and wiring the new array panels
- Wiring the arrays and incorporating the wiring into the system
- Hardware costs which would include purchasing 392 array panels (approximate cost \$350 per panel plus \$7,000 for installation materials)

Adding the yellow area panels would include the following:

- Building and installing the array frames, support structure and wiring infrastructure.
- Installing and wiring the new array panels
- Wiring the arrays and incorporating the wiring into the system
- Hardware costs which would include purchasing 192 array panels (approximate cost \$350 per panel plus \$7,000 for installation materials)

Adding the green area panels would include the following:

- Installing the support footers, building and installing the array frames, support structure and wiring infrastructure.
- Installing and wiring the new array panels
- Wiring the arrays and incorporating the wiring into the system
- Hardware costs which would include purchasing 192 array panels (approximate cost \$350 per panel plus \$10,000 for installation materials)

Wind Turbine

Wind turbines or windmills convert wind energy to electricity by using aerodynamic forces to spin a turbine that in turn spins a generator. Most wind turbines have three turbine blades. The size and shape of the blades will determine how much power the windmill is capable of generating under various wind conditions. Aside from the turbine size; the wind speed is the most important factor in determining how much electrical power can be extracted from the wind. The power that can be extracted from the wind is proportional to the cube of the wind velocity. This means that if the wind speed doubles the power output goes up by a factor of eight. The height of the wind turbine is also important. Trees and the boundary layer effect will tend to slow the wind down near the surface. To maximize the output of the wind turbine it will need to be elevated to avoid these effects.

The required size of the wind turbine will be based on the power requirements of the hydrogen generating station and the available average wind speed. The maximum power a wind turbine can extract from the wind is given by the following equation. The power is dependent on the air density (ρ), the wind velocity (V) and the circular area swept out by the turbine blades (A).

$$P = 0.593 (1/2) \rho V^3 A \quad (4.1)$$

As represented by this equation, the maximum percent of the total energy contained within the wind that can be extracted is 59.3 percent. In practice however, the actual output of the wind turbine will be less. Items such as the aerodynamic efficiency of the blades and losses in the rotating machinery (bearings, gears etc.) can bring the total output to less than half that calculated by the above equation. An estimate of the overall operating efficiency of the wind turbine is around 30 percent (ref. 11). Figure 4.13 shows how the output for the wind turbine will vary with wind speed and turbine diameter. This graph was generated for a 30 percent efficient wind turbine using standard atmospheric conditions (density of 1.225 kg/m³ at sea level and 15 °C (59 °F) temperature). This density value will change with altitude and temperature. This change is shown in figure 4.14. From this figure it can be seen that in the winter months the output of the wind turbine can increase to upwards of 10 percent for a given wind speed due to the air density increase with decreasing temperature.

Wind turbines are designed to operate most efficiently at one wind speed. This optimization is a combination of blade design and generator characteristics. At the site of operation however, the wind speed will vary greatly throughout any given day and more broadly over the entire year. There will be a mean wind speed over a given period of time, such as a month or year. For Cleveland the mean and maximum wind speed throughout the year is shown in figure 4.15. The mean wind speed, however, is not necessarily the wind speed that should be chosen as the turbine design wind speed. As shown in figure 4.13 the output power of the turbine will increase greatly as wind speed increases. Therefore, based on the wind distribution there will be a wind speed that provides the maximum output power over the year. To determine this a typical wind speed distribution for a year period is used. Since we do not have wind data available at the actual site for this period of time an approximation will be made. This approximation is based on the mean wind speed for the area. A Rayleigh distribution is used to provide a statistical wind speed profile for the year and is represented by equations (4.2) and (4.3). This wind distribution is based on the mean wind speed (V_m) and is plotted as a function of wind velocity (V).

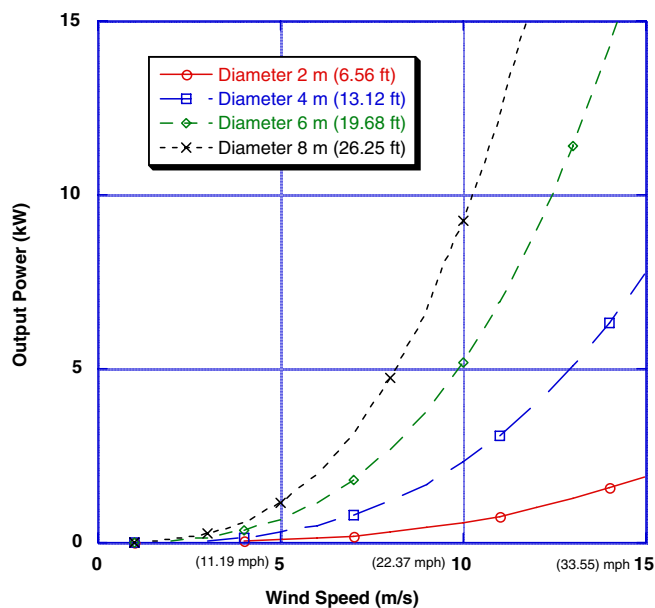

Figure 4.13.—Wind turbine output versus wind speed and turbine diameter.

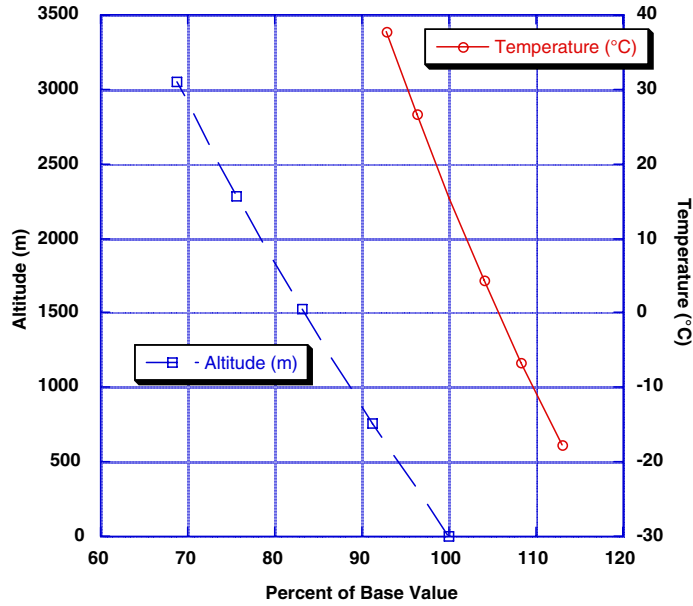

Figure 4.14.—Change in air density with altitude and temperature.

$$T(\text{hours per year}) = 8760 \left(\frac{\pi}{2}\right) \left(V/V_m^2\right) \left(e^{-K}\right) \quad (4.2)$$

$$K = \left(\frac{\pi}{4}\right) \left(V/V_m\right)^2 \quad (4.3)$$

This distribution is shown in figure 4.16 for the yearly site mean wind speed of 4.7 m/s. Also shown in this figure is the yearly available energy distribution (in W-hr per year) that is achievable with various size wind turbines. As in figure 4.13 these curves represent a 30 percent efficient wind turbine at standard atmospheric conditions.

The peak of this energy distribution curve is the optimal speed for the wind turbine. For this case the optimal design speed is approximately 7.8 m/s. This means that to achieve the best yearly performance out of the wind turbine its highest efficiency point should be when it is operating at that speed.

The height of the wind turbine will be dependent on the surrounding terrain. It was estimated that the highest trees and buildings near the potential site of the wind turbine are approximately 22 m (72 ft) high. The wind speeds will be significantly reduced below this tree line. This boundary layer region of reduced wind speed will extend upward beyond the tree height. The mean wind speed given previously was for a height of approximately 10 m (33 ft) at a clear location with little surrounding trees. To determine the wind height profile a correction must be used to account for this boundary layer as well as taking into account the surrounding tree height.

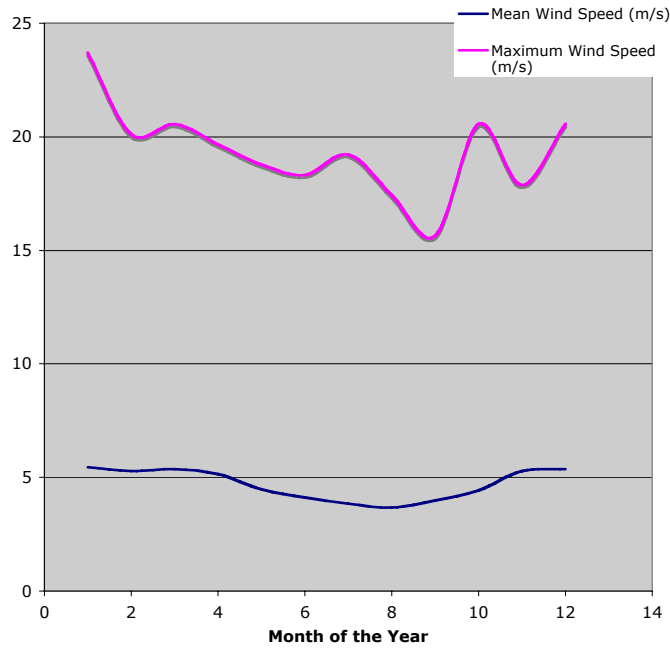

Figure 4.15.—Mean and maximum wind speeds throughout the year for Cleveland (ref. 12).

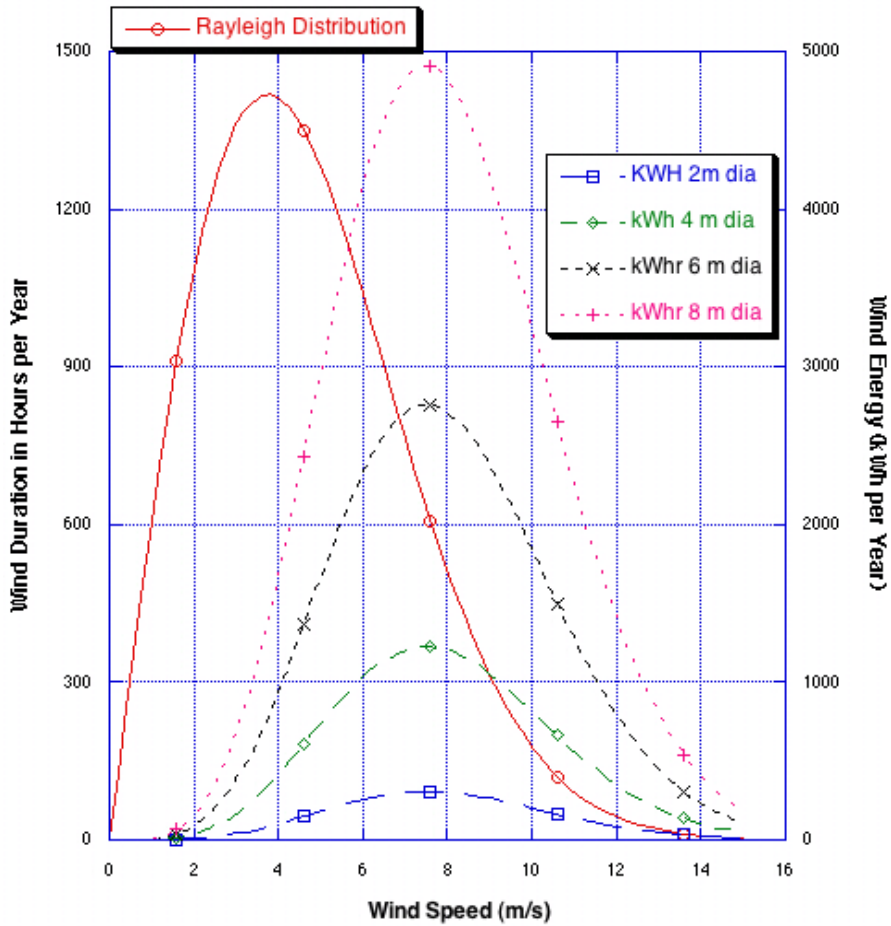

Figure 4.16.—Wind speed distribution and available yearly energy.

First it is assumed that the boundary layer formation starts at the treetops. This height of 22 m (72 ft) is therefore equivalent (from the boundary layer perspective) to the ground at the location where the mean wind speed data was taken. The estimated friction coefficient for the tree top surface is 0.28. The boundary layer profile above the tree line is determined from the following equation.

$$V = V_m (h/h_m)^{0.28} \tag{4.4}$$

Where V is the velocity at a height above the treetops and V_m and is the mean velocity. The values h and h_m are height correction factors, which can be determined from figure 4.17. For a height of 10 m (33 ft) above the tree line the value of h_m will be approximately 1.01. Figure 4.17 shows the velocity profile above the tree line based on equations (4.2) and (4.3) as well as the corresponding percent change in output power of the wind turbine. Every ten meters in wind turbine height yields an increase in output power of approximately 15 percent. Therefore the higher the wind turbine can be placed the better. However there is a practical limit on the height at which the wind turbine can be placed. A practical limit for the tower size at this site would be between 37 m (~120 ft) to 45m (~150 ft). This would provide an increase in average output power, over that corresponding to the mean wind velocity listed above, of 7.5 to 20 percent.

Due to the estimated height of the wind turbine, the tower selection and installation is a critical part of the system's design. A complete understanding of the loads the tower will encounter is crucial to selecting the best tower for this system. Wind gusts are potentially the most damaging environmental event that can occur to both the wind turbine as well as the tower. The main approach for dealing with wind gusts is to estimate the number and magnitude of the gusts that can be expected at the site and design the system to withstand up to the 99th percentile gusts.

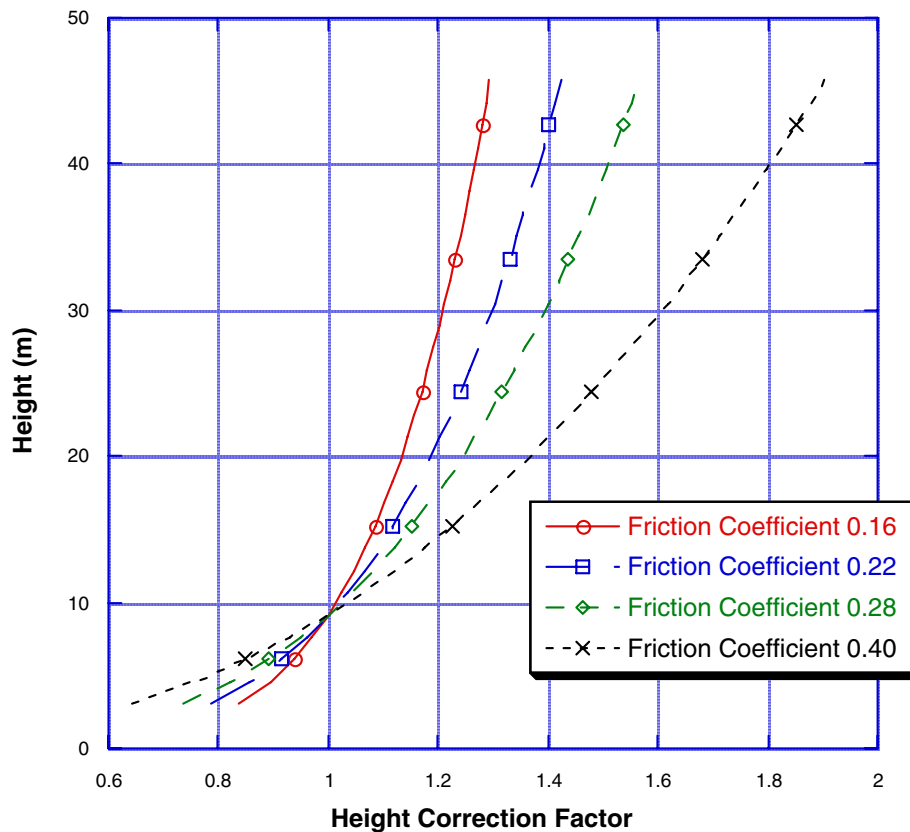

Figure 4.17.—Height correction factor for boundary layer velocity calculation.

A safety issue for the complete system but especially the wind turbine is lightning strikes. The wind turbine will be a prime target for lightning strikes since it will be the tallest metal object around. On average the Cleveland area has about 35 days of the year in which thunderstorms will form (ref. 12). Although this number is not that great, any individual lightning strike can be very destructive. The current in an average lightning bolt typically peaks at around 20,000 A but can reach levels of 100,000 A. This is more than capable of destroying the wind turbine as well as other parts of the system. The solution to this problem is fairly simple. A lightning rod will need to be installed on the top of the tower, above the wind turbine. This rod will need to be connected with heavy gauge wire to grounding rods that are 2.5 m (~8 ft) to 3 m (~10 ft) in the ground.

The tower will also need to be positioned to minimize the danger if the tower collapsed or a blade from the wind turbine broke off. This means placing the tower a minimum of one and a half times its length away from any building or structure.

Based on the graphs presented in figures 4.13 through 4.18, a wind turbine can be selected that would optimize the available wind resource at the site. The amount of power desired will dictate the wind turbine size. Also, multiple lower power (smaller) turbines can be used to achieve a given power level. A list of potential wind turbines and their manufacturers is given in Table 4.3. This table lists the specifications of the best candidates.

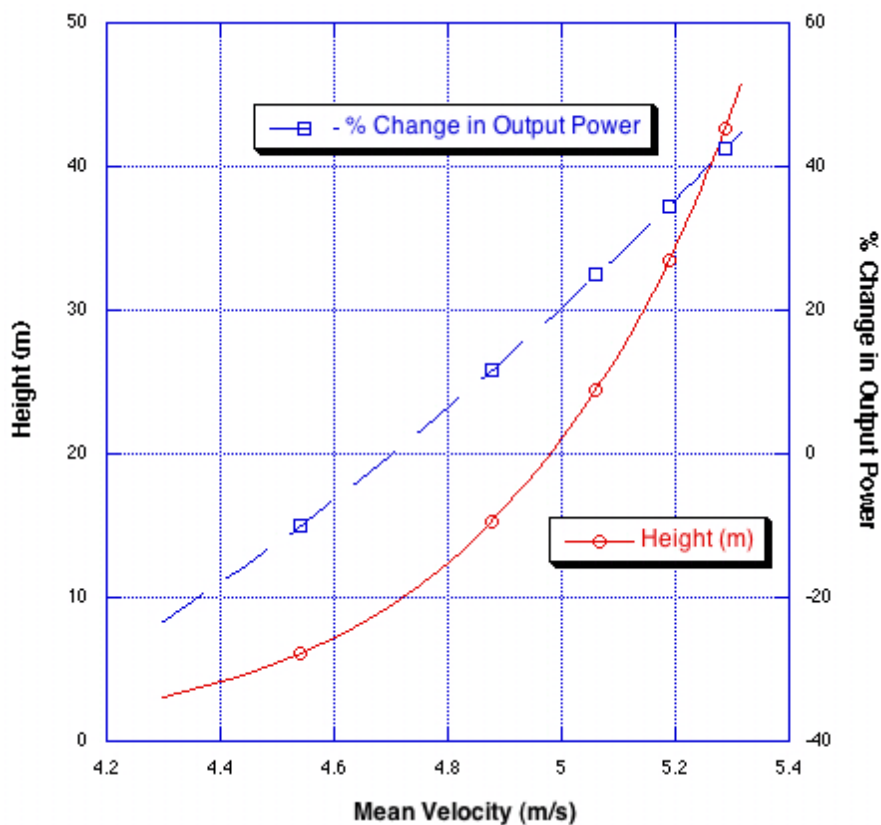

Figure 4.18.—Velocity profile and percent change in output power above tree line.

TABLE 4.3.—WIND TURBINE CHARACTERISTICS

Manufacturer (model)	Rotor diameter	Number of blades	Output power @ rated wind speed	Startup wind speed	Max wind speed	Mass, weight
Atlantic Orient Corp. (8/12 Geared)	8 m	3 wood epoxy blades	12 kW at 11 m/s	NA	NA	NA
Atlantic Orient Corp. (Windlite)	7 m	3 fiber-glass blades	10 kW at 10.5 m/s	NA	NA	NA
Southwest Windpower (Whisper 175)	5 m	2 blades	3.2 kW at 12 m/s	3.1 m/s	NA	55 kg (175 lb)
Southwest Windpower (Whisper H80)	3 m	3 blades	1 kW at 10.5 m/s	3.1 m/s	NA	30 kg (65 lb)
Proven Engineering Products Ltd. (WT6000)	5.5 m	3 blades	6 kW at 10 m/s	2.5 m/s	> 70 m/s	204 kg (450 lb)
Proven Engineering Products Ltd. (WT2500)	3.5 m	3 blades	2.5 kW at 12 m/s	2.5 m/s	> 70 m/s	86 kg (190 lb)
Bergey Windpower (BWC Excel)	7 m	3 blades	10 kW at 13.8 m/s	3.4 m/s	54 m/s	NA
Bergey Windpower (BWC 1500)	3 m	3 blades	1.5 kW at 12.5 m/s	3.6 m/s	54 m/s	NA
Entegrity Wind Systems, EW15	15 m	3 blades	50 kW at 11.3 m/s	4.6 m/s	22.4 m/s	2,420 kg (5,340 lb)
Wind Turbine Industries, 31-20	9.4 m	3 blades	20 kW at 12 m/s	3.6 m/s	54 m/s	1,136 kg (2500 lb)

Many of the wind turbine companies also manufacture towers that are designed for specific turbines. Depending on the turbine or turbines that are ultimately chosen it may be possible to obtain the tower from the same manufacturer. Based on the survey that was done the maximum tower height offered by most manufacturers is around 36.5 m (120 ft). This is on the low end of the desired wind turbine range for this site but should be sufficient for its operation. Due to the height of this tower it will need to be professionally installed in order to ensure safe operation of the wind turbine.

The cost of the wind turbine, tower and installation will vary by manufacturer. As an example the cost of a Wind Turbine Industries 31-20 wind turbine is given in table 4.4. The generator for this turbine is a Brushless, synchronous 3-phase ac generator. The output voltage is within the range of 40 to 180 Vac. The output power curve for this wind turbine is given in figure 4.19. From this figure it can be seen that although the turbine is rated at 20 kW output this only occurs at wind speeds greater than 12 m/s (~27 mph). At the design wind speed for this system (7.8 m/s, ~18 mph) the wind turbine will deliver 7 kW.

TABLE 4.4.—COST ESTIMATE FOR WIND TURBINE SYSTEM INSTALLATION (REF. 13)

Component	Cost
31-20 wind turbine (20 kW rated)	\$26,000
36.5 m (120 ft) tower	\$14,500
Installation and misc. hardware	\$15,000
Total cost	\$55,500

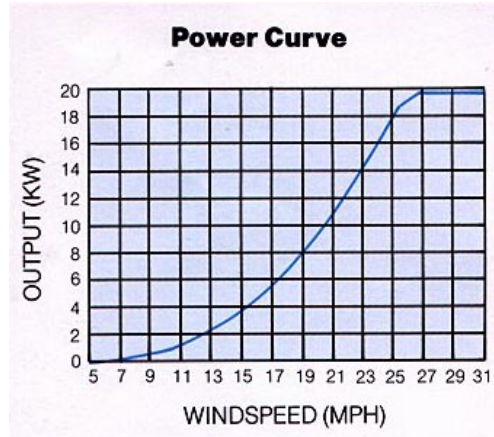

Figure 4.19.—Output power versus wind speed for the Wind Turbine Industries 31-20 Wind Turbine (ref. 13)

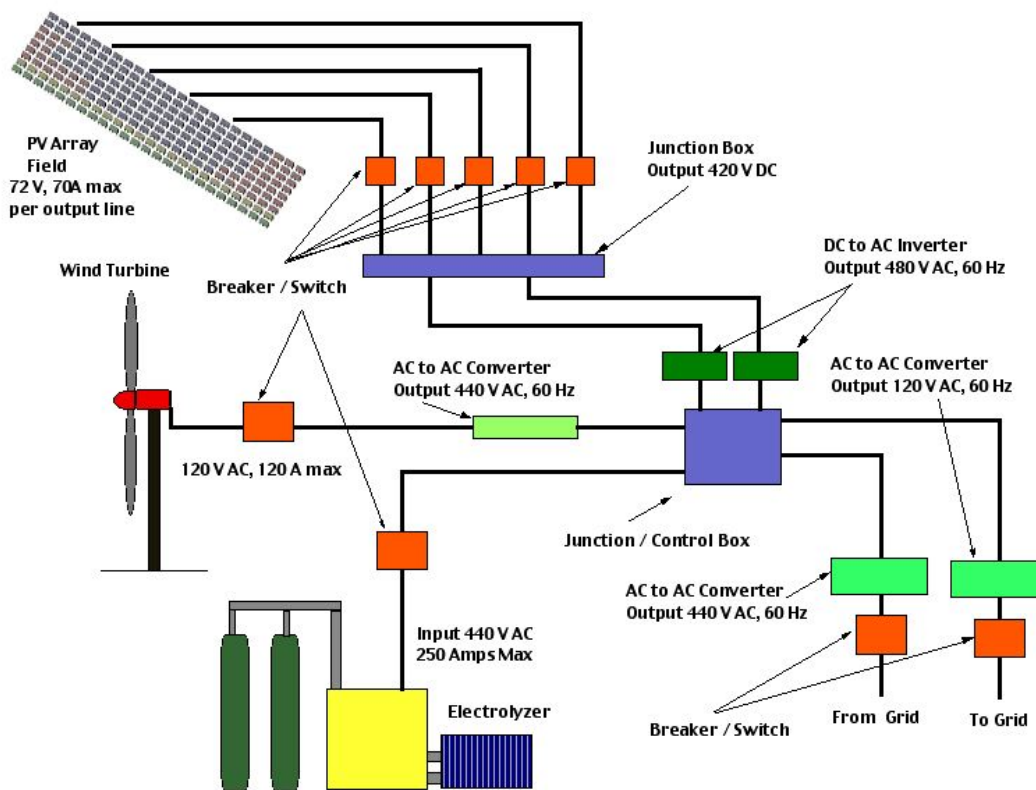

Figure 4.20.—Power management layout for the Hydrogen Generation System.

System Integration

In order for the Hamilton Standard electrolyzer to utilize the power produced by the array and wind turbine it must be conditioned. The electrolyzer’s input power requirements are 3 phase, 440 V ac at 60 Hz so in order to achieve this a series of inverters and converters must be employed. A diagram of the required power conditioning equipment is shown in figure 4.20.

The components of the power management system consist of dc to ac inverters and ac-to-ac converters. The dc to ac inverters are used to convert the power from the PV array to the required 440 ac power for the electrolyzer. The present system has an ABC 150 dc to ac inverter. This inverter can handle

power levels up to 150 kW. (Two 75 kW dc power sources). This will be capable of handling the full output power of the array if all the upgrades are performed. The dc input voltage for the inverter is 420 V and the output is 3-phase, 480 V ac. In addition to the existing dc to ac inverter additional ac-to-ac converters will be needed to convert the ac output voltage from the wind turbine to be compatible with the electrolyzer and to convert the voltage to and from the grid. A summary of the components of the power management system is given in table 4.5.

TABLE 4.5.—POWER MANAGEMENT EQUIPMENT

Component	Manufacturer/model	Specifications	Price
ac to ac converter	TEMCO T-3-53312-3S	Input: 120 V ac Output: 440 V ac Power: 30 kW	\$1,900 each
ac to ac converter	TEMCO T-3-53314-3S	Input: 120 V ac Output: 440 V ac Power: 75 kW	\$3,500 each
ac to ac converter	TEMCO T-3-53314-3S	Input: 440 V ac Output: 120 V ac Power: 75 kW	\$3,500 each
Miscellaneous equipment: breaker switches, cabinets, wire, mounts and control system (software and hardware)	Various	Various	\$5,000 est.
Total for present array configuration			\$8,500
Total for array upgrade			\$8,500
Total for upgrade and red panels			\$8,500
Total for upgrade, red and yellow panels			\$8,500
Total for upgrade, red , yellow and green panels			\$8,500
Total for full array and wind turbine			\$10,400

Site Installation and Performance

There are a number of factors, which will influence the site selection for the electrolyzer. The main issues are the distance from the renewable power source, the array field and wind turbine, and the distance from a safe location to store the hydrogen gas. Based on these issues, the proposed site for the electrolyzer is behind building 333 off of Guerin Road, next to the present hydrogen storage facility. There are a number of benefits to the placement of the electrolyzer at this location. These include.

- The electrolyzer will be next to an already existing hydrogen storage facility, minimizing any safety implications of storing the produced hydrogen.
- It will be just off of Guerin Road providing easy access by vehicle as well as providing a means of supporting a hydrogen refueling station.
- It is relatively close to the array field, buildings 333 and 334.

To install the electrolyzer at this site a small shed or building will be needed. Also the power lines from the renewable sources and grid will need to be brought to the building as well as a water supply line. The building will need to be large enough to house the electrolyzer and some miscellaneous equipment as well as enable personnel to walk into it for servicing and operation of the system. Heating and ventilation will also need to be provided within the building.

A precast concrete building can be used to house the electrolyzer. These buildings come in various sizes. For this application, a 10 ft by 12 ft (2.5 m by 3.0 m) building should be sufficient. An example of this type of building is shown in figure 4.21.

Along with the electrolyzer a water deionization system will be installed within the enclosure (also shown in fig. 4.21). This water purification system will treat the incoming water to provide the purity needed by the electrolyzer. The maximum rate of deionized water that will be required is 0.5 gpm.

To size the tank volume needed to store the hydrogen gas, an estimate for the hydrogen production rate must be made. The maximum hydrogen volumetric production rate (\dot{V}_a) for the electrolyzer is 8.4 m³ (300 ft³/hr) hydrogen per hour at standard atmospheric conditions, of 1 atmosphere pressure (P_a). The output and therefore storage pressure (P) of the hydrogen gas from the electrolyzer is at 20.7 MPa (3000 psi). The output volume per hour (\dot{V}) at this increased pressure is given by equation (4.5).

$$\dot{V} = \frac{P_a \dot{V}_a (0.99704 + (6.4149E - 9)P)}{P(0.99704 + (6.4149E - 9)P_a)} \quad (4.5)$$

Assuming that the electrolyzer will only be operated off of the renewable power sources, the amount of hydrogen produced can be calculated based on the total energy produced by the solar array and wind turbine. For this hydrogen production calculation, it is assumed that the electrolyzer can utilize all of the energy produced by the renewable sources. This cannot actually be achieved without some form of energy storage. This is because the maximum power output from these sources will at times be greater than the maximum input power for the electrolyzer. Therefore to totally utilize the energy produced, a storage medium will be needed. For this analysis it is assumed that the electrical grid will act as the storage medium. When more power is available from the renewable sources than the electrolyzer can handle, either due to the maximum power limitation of the electrolyzer or the hydrogen storage capacity being full, the excess power will be sent to the grid. Alternatively, when insufficient power is available from the renewable sources the electrolyzer will draw off of the grid to produce hydrogen. The assumption being made is that the total excess power being transferred to the grid throughout the year will equal the makeup power extracted from the grid by the electrolyzer throughout the year. Based on this assumption, the total energy output from the renewable sources can be utilized to size the hydrogen storage tanks.



Figure 4.21.—Precast concrete building for housing the electrolyzer and water deionization unit.

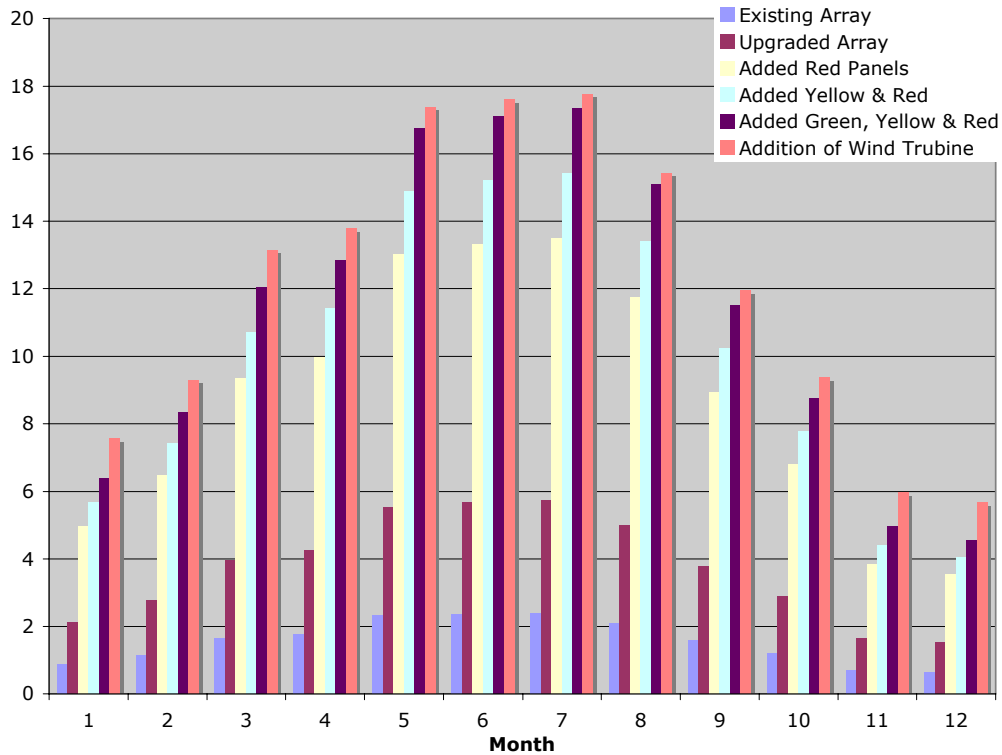

Figure 4.22.—Hydrogen production per month for the various upgrades of the renewable energy system.

Therefore, utilizing the energy output from the renewable sources and the power consumption and hydrogen production rate of the electrolyzer, the total hydrogen production capability per month can be calculated. This is shown in figure 4.22 for the various levels of renewable system installation.

The amount of storage needed will ultimately be determined by how quickly the hydrogen produced is utilized. However, at this time the usage rate is not known. Therefore it will be assumed that a half months worth of storage is required. To ensure that this can be accomplished the month with the highest production rate (July) will be utilized. The estimated storage requirements based on the installed renewable energy source are given in table 4.6.

TABLE 4.6.—HYDROGEN STORAGE REQUIREMENTS @ 3000 PSI FOR THE VARIOUS RENEWABLE POWER SYSTEM UPGRADES

Renewable Energy System	Storage requirement (m ³)
Existing system	1.2
Upgraded existing system	2.9
Upgraded system with addition of red panels	6.8
Upgraded system with addition of red and yellow panels	7.7
Upgraded system with addition of red, yellow and green panels	8.7
Full array with the addition of the wind turbine	8.9

The last component of the electrolyzer installation is a coolant chiller. This chiller will provide coolant water to the electrolyzer through a closed loop cooling system. The water is recirculated through the chiller to remove the added heat from the electrolyzer operation and then passed back through the electrolyzer. The power required to operate the chiller will be provided by the renewable power sources. The chiller will need to dissipate a maximum of around 25 kW of thermal power. This amount of heat requires a fairly substantial chiller system. An example of a chiller that can meet these requirements is the NesLab HX-750. This chiller is shown in figure 4.23.



Figure 4.23.—NesLab HX-750 Recirculating Chiller.

The water purification system and coolant chiller will be installed in the building along with the electrolyzer. The cost estimate for installing the electrolyzer is summarized in table 4.7.

The last component of the electrolyzer installation is a coolant chiller. This chiller will provide coolant water to the electrolyzer through a closed loop cooling system. The water is recirculated through the chiller to remove the added heat from the electrolyzer operation and then passed back through the electrolyzer. The power required to operate the chiller will be provided by the renewable power sources. The chiller will need to dissipate a maximum of around 25 kW of thermal power. This amount of heat requires a fairly substantial chiller system. An example of a chiller that can meet these requirements is the NesLab HX-750. This chiller is shown in figure 4.23.

The water purification system and coolant chiller will be installed in the building along with the electrolyzer. The cost estimate for installing the electrolyzer is summarized in table 4.7.

TABLE 4.7.—COST ESTIMATE FOR ELECTROLYZER INSTALLATION

Item	Manufacturer/model	Estimate cost
Precast building: purchase and install building	APS Concrete Products Inc.	\$15,000
Water supply: install waterline and purification equipment	Big Brand Water Filter/CMP-800	\$7,000
Power line: install power line to electrolyzer	Various	\$5,000
Hydrogen storage: purchase and install hydrogen storage tanks and dispensing system	Various	\$15,000
Cooling system: purchase and install chiller system	NesLab/HX-750	\$8,900
Total		\$50,900

References

1. "Manual for Electrolyzer Oxygen Generation Plant (OGP), Operations Manual," JPL, Contract no. NAS-7-918, Dec. 1993.
2. Avalence LLC. Product Information, Company Website <http://avalence.com/>, Feb. 2006.
3. Hydrogenics Corporation. Product Information, Company Website <http://www.hydrogenics.com/>, Feb. 2006.
4. Linde Gas. Product Information, Company Website <http://www.linde-gas.com/>, Feb. 2006.
5. Norsk Hydro. Product Information, Company Website <http://www.hydro.com/en/index.html>, Feb. 2006.
6. Proton Energy Systems. Product Information, Company Website <http://www.protonenergy.com/>, Feb. 2006.
7. Teledyne Energy Systems, Company Website <http://www.teledyneenergysystems.com/>, Feb. 2006.
8. Treadwell Corporation, Company Website <http://www.treadwellcorp.com/>, Feb. 2006.
9. Kohout, L.L., Merolla, A. and Colozza, A. "A Solar Photovoltaic Power System for Use in Antarctica," NASA TM-106417, Dec. 1993.
10. Siemens, Solar Module SM55 Data Sheet, Siemens Solar Industries, Mar. 1998.
11. Park, J., *The Wind Power Book*, Cheshire Books, 1981.
12. The State Climatology Office for Ohio, <http://www.geography.ohio-state.edu/faculty/rogers/statclim.html>, Jan. 2006.
13. Wind Turbine Industries Corp., web site, <http://www.windturbine.net/>, Jan. 2006.

REPORT DOCUMENTATION PAGE

*Form Approved
OMB No. 0704-0188*

The public reporting burden for this collection of information is estimated to average 1 hour per response, including the time for reviewing instructions, searching existing data sources, gathering and maintaining the data needed, and completing and reviewing the collection of information. Send comments regarding this burden estimate or any other aspect of this collection of information, including suggestions for reducing this burden, to Department of Defense, Washington Headquarters Services, Directorate for Information Operations and Reports (0704-0188), 1215 Jefferson Davis Highway, Suite 1204, Arlington, VA 22202-4302. Respondents should be aware that notwithstanding any other provision of law, no person shall be subject to any penalty for failing to comply with a collection of information if it does not display a currently valid OMB control number.

PLEASE DO NOT RETURN YOUR FORM TO THE ABOVE ADDRESS.

1. REPORT DATE (DD-MM-YYYY) 12-04-2007		2. REPORT TYPE Final Contractor Report		3. DATES COVERED (From - To)	
4. TITLE AND SUBTITLE Hydrogen Generation Through Renewable Energy Sources at the NASA Glenn Research Center				5a. CONTRACT NUMBER NAS3-02150-100	
				5b. GRANT NUMBER	
				5c. PROGRAM ELEMENT NUMBER	
6. AUTHOR(S) Collozza, Anthony; Prokopius, Kevin				5d. PROJECT NUMBER	
				5e. TASK NUMBER	
				5f. WORK UNIT NUMBER WBS 22R-9526-89-L0F2-04	
7. PERFORMING ORGANIZATION NAME(S) AND ADDRESS(ES) Analex Corporation 1100 Apollo Drive Brook Park, Ohio 44142				8. PERFORMING ORGANIZATION REPORT NUMBER E-15832	
9. SPONSORING/MONITORING AGENCY NAME(S) AND ADDRESS(ES) National Aeronautics and Space Administration Washington, DC 20546-0001				10. SPONSORING/MONITORS ACRONYM(S) NASA	
				11. SPONSORING/MONITORING REPORT NUMBER NASA/CR-2007-214682	
12. DISTRIBUTION/AVAILABILITY STATEMENT Unclassified-Unlimited Subject Categories: 28 and 44 Available electronically at http://gltrs.grc.nasa.gov This publication is available from the NASA Center for AeroSpace Information, 301-621-0390					
13. SUPPLEMENTARY NOTES					
14. ABSTRACT An evaluation of the potential for generating high pressure, high purity hydrogen at the NASA Glenn Research Center (GRC) was performed. This evaluation was based on producing hydrogen utilizing a prototype Hamilton Standard electrolyzer that is capable of producing hydrogen at 3000 psi. The present state of the electrolyzer system was determined to identify the refurbishment requirements. The power for operating the electrolyzer would be produced through renewable power sources. Both wind and solar were considered in the analysis. The solar power production capability was based on the existing solar array field located at NASA GRC. The refurbishment and upgrade potential of the array field was determined and the array output was analyzed with various levels of upgrades throughout the year. The total available monthly and yearly energy from the array was determined. A wind turbine was also sized for operation. This sizing evaluated the wind potential at the site and produced an operational design point for the wind turbine. Commercially available wind turbines were evaluated to determine their applicability to this site. The system installation and power integration were also addressed. This included items such as housing the electrolyzer, power management, water supply, gas storage, cooling and hydrogen dispensing.					
15. SUBJECT TERMS Hydrogen; Fuels; Electrolysis; Hydrogen production; Windpower utilization; Solar arrays; Solar energy conversion					
16. SECURITY CLASSIFICATION OF:			17. LIMITATION OF ABSTRACT	18. NUMBER OF PAGES 42	19a. NAME OF RESPONSIBLE PERSON Mark Hoberecht
a. REPORT U	b. ABSTRACT U	c. THIS PAGE U			19b. TELEPHONE NUMBER (include area code) 216-433-5362

