

IMPLEMENTATION OF LEAK TEST METHODS FOR THE INTERNATIONAL SPACE STATION (ISS) ELEMENTS, SYSTEMS AND COMPONENTS

Steve Underwood⁽¹⁾, Oleg Lvovsky⁽²⁾

⁽¹⁾The Boeing Company 499 Boeing Boulevard Huntsville, AL, USA, Email: steve.d.underwood@boeing.com

⁽²⁾ARES Corp., 16441 Space Center Blvd., Bldg. A, Houston, TX, USA, Email: olvosvsky@arescorporation.com

ABSTRACT

The International Space Station (ISS) has Qualification and Acceptance Environmental Test Requirements document, SSP 41172 that includes many environmental tests such as Thermal vacuum & Cycling, Depress/Repress, Sinusoidal, Random, and Acoustic Vibration, Pyro Shock, Acceleration, Humidity, Pressure, Electromagnetic Interference (EMI)/Electromagnetic Compatibility (EMCO), etc. This document also includes (13) leak test methods for Pressure Integrity Verification of the ISS Elements, Systems, and Components. These leak test methods are well known, however, the test procedure for specific leak test method shall be written and implemented paying attention to the important procedural steps/details that, if omitted or deviated, could impact the quality of the final product and affect the crew safety. Such procedural steps/details for different methods include, but not limited to:

- Sequence of testing, for example, pressurization and submersion steps for Method I (Immersion);
- Stabilization of the mass spectrometer leak detector outputs for Method II (vacuum Chamber or Bell jar);
- Proper data processing and taking a conservative approach while making predictions for on-orbit leakage rate for Method III (Pressure Change);
- Proper Calibration of the mass spectrometer leak detector for all the tracer gas (mostly Helium) Methods such as Method V (Detector Probe), Method VI (Hood), Method VII (Tracer Probe), Method VIII (Accumulation);
- Usage of visibility aides for Method I (Immersion), Method IV (Chemical Indicator), Method XII (Foam/Liquid Application), and Method XIII (Hydrostatic/Visual Inspection);

While some methods could be used for the total leakage (either internal-to-external or external-to-internal) rate requirement verification (Vacuum Chamber, Pressure Decay, Hood, Accumulation), other methods shall be used only as a pass/fail test for individual joints (e.g., welds, fittings, and plugs) or for troubleshooting

purposes (Chemical Indicator, Detector Probe, Tracer Probe, Local Vacuum Chamber, Foam/Liquid Application, and Hydrostatic/Visual Inspection). Any isolation of SSP 41172 requirements have led to either retesting of hardware or accepting a risk associated with the potential system or component pressure integrity problem during flight.

INTRODUCTION

Boeing in was the prime contractor for building, outfitting, and testing of the U.S. pressurized modules for the International Space Station: the Airlock, Laboratory, and Node 1 modules. This work was performed at Marshall Space Flight Center in Huntsville, Alabama. Each of these modules has a total allowable leakage rate of about one tenth of a pound of air per day, a requirement based on the available re-supply gas. Component-level and system-level requirements based on hardware capability are more stringent, and are the basis for the lower-level leak tests to ensure good hardware installations.

The Node 1 or "Unity" module contains six ports and is used for interconnection of modules in space. The U.S. Laboratory module will house equipment and experiment racks, and the Airlock module will provide crew members access to space for extravehicular activity (EVA). Figure 1 shows the Node 1, U.S. Lab, and Airlock modules. Potential leakage paths to space include the module structure, made of machined and formed aluminum panels welded together, and feedthrough penetrations in the module structures through which fluids and power pass to different areas on the station. Other leakage paths are the Common Berthing Mechanisms (CBMs) that mate the various modules together, the Hatches that close out the modules, and windows that allow crew observations of external activities and space. A summary flow chart of the leak testing activities for acceptance of the flight hardware is shown in Figure 2.

Hatch (6 places)

Common Berthing Mechanism (CBM)
(6 places)

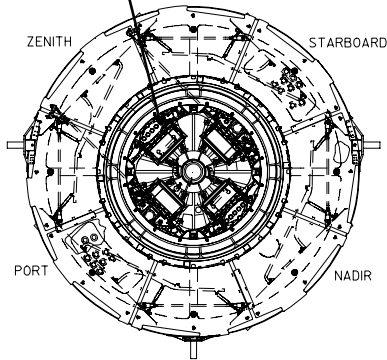

Node 1 End View

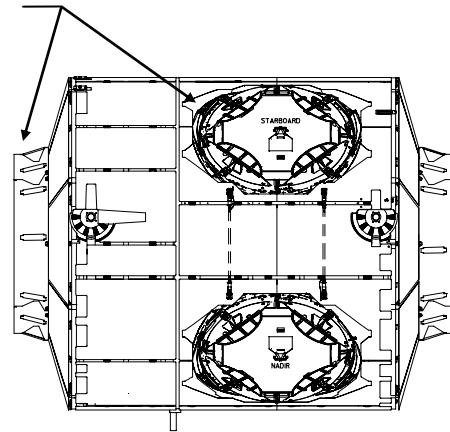

Node 1 Side View

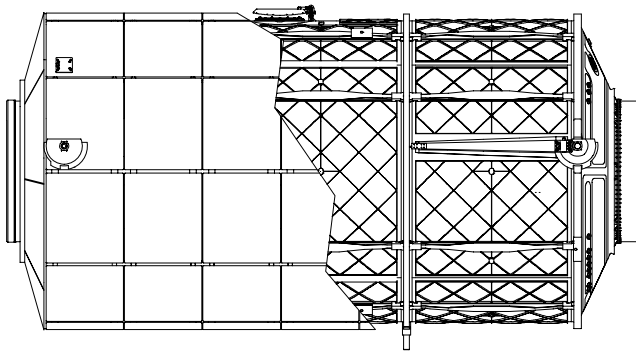

U.S. Laboratory

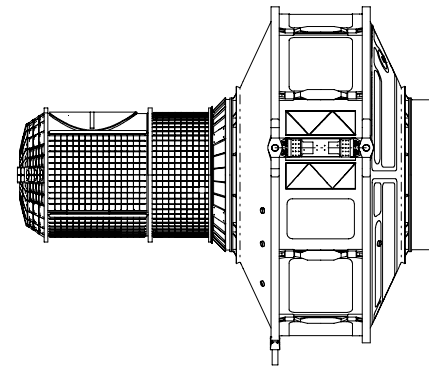

Airlock

Figure 1: Boeing-built International Space Station Pressurized Modules

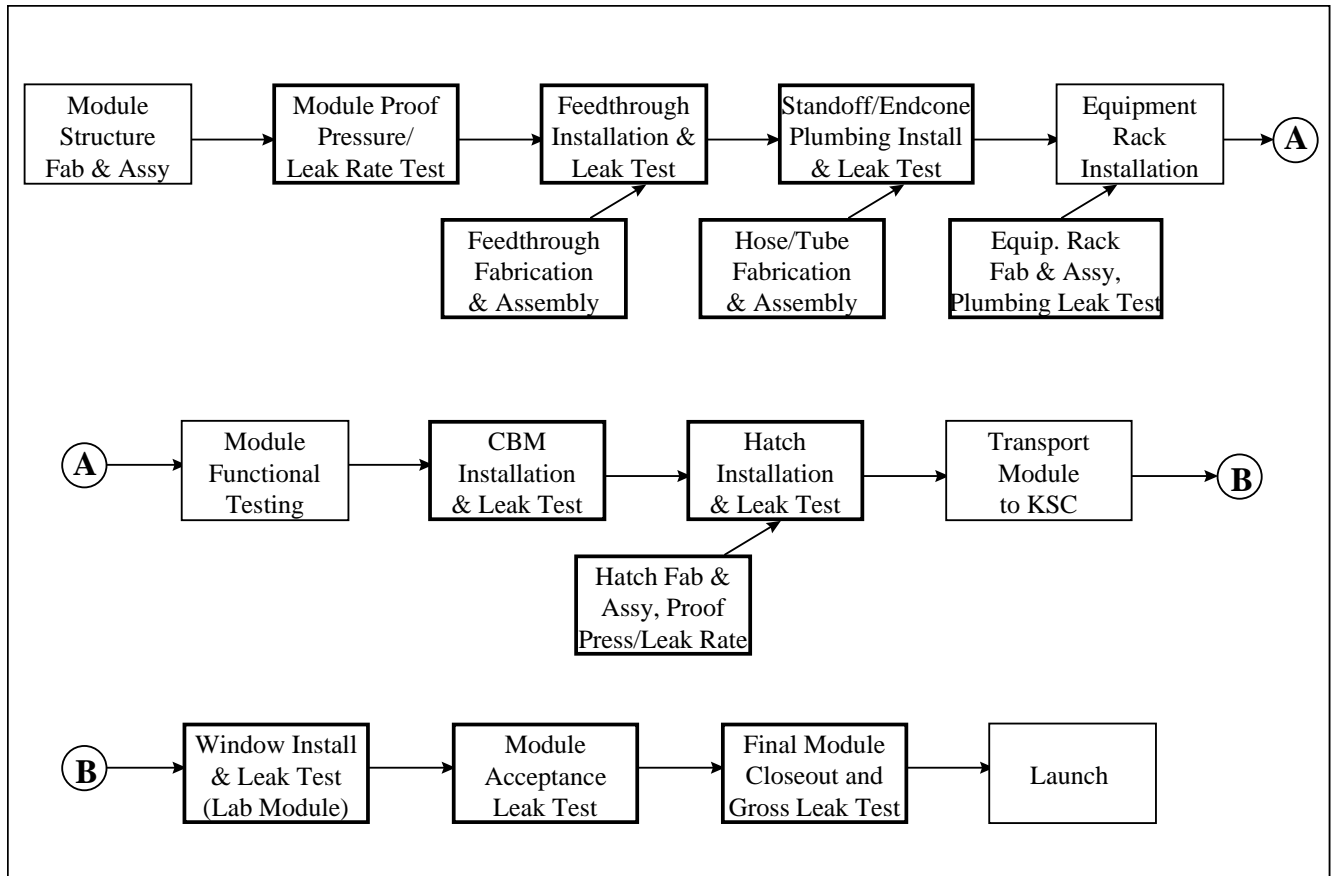

Figure 2: International Space Station Module Acceptance Leak Test Flow

STRUCTURAL WELD LEAK TESTING

Leak tests of the structural welds were performed immediately following a 22.8 psig proof pressure test of the modules in 1996 and 1997. The leak test method was a helium detector probe test using helium mass spectrometer leak detectors (MSLDs). The modules were pressurized to 12-14.7 psig for an 87% helium concentration. Portable counter-flow MSLDs were used in conjunction with 75 foot sniffer hoses, and welds were sniffed at a speed of 1 foot/minute. Probe heads which conformed to the weld surfaces were installed over the tip of the detector probes to increase test sensitivity.

The requirement for weld leakage was 1E-4 sccs helium per linear inch of weld. Calibrated helium leaks sized slightly smaller than the requirement were installed on weld test plates and were used to calibrate the detector probes by passing the probe head over the leak and recording the MSLD response. This calibration was performed prior to start of sniffing, a minimum of every hour thereafter,

whenever detector probe operators were changed, and before shutting down the test. The calibration verified that the operator's technique and the equipment's operation were sufficient to detect a leak equal to or less than the requirement. Over 1000 feet of structural welds were tested in this manner.

FEEDTHROUGH LEAK RATE TESTING

Feedthroughs are installed in the module structure to route power, data, and fluids to the ISS modules. The Node 1 module contains 160 feedthroughs, the Laboratory module contains 100 feedthroughs, and the Airlock module contains 40 feedthroughs. The feedthroughs were leak tested following installation to verify a proper installation. The leak rate requirement for the feedthrough leak test was 5E-6 sccs air, and was verified with a helium mass spectrometer leak detector (MSLD) hood test. The test setup is shown in Figure 3.

The feedthrough leak test procedure is as follows: A bell jar is placed over the external side of the feedthrough and evacuated to 1E-2 torr with an MSLD. A helium containment hood is installed over the internal side of the feedthrough. Helium is injected into the hood and the MSLD output is recorded until the feedthrough seals are fully permeated and a leak rate is obtained.

In addition to verifying the total leak rate of the feedthrough seals, the ISS also has a requirement to verify that the seal installation meets its redundancy requirement. Each ISS sealed joint is required to

have a minimum two seals, and must be tested on the ground prior to launch. ISS seals larger than six inches in diameter have leak check ports which provide access between the two seals for leak testing each seal individually. The feedthrough seals, however, have no leak check ports, so the redundancy is verified through analysis of the feedthrough permeation curves. (Permeation through two seals is slower and lower in magnitude than permeation through one seal.) Many installation problems were detected and corrected by using the permeation data to verify seal redundancy.

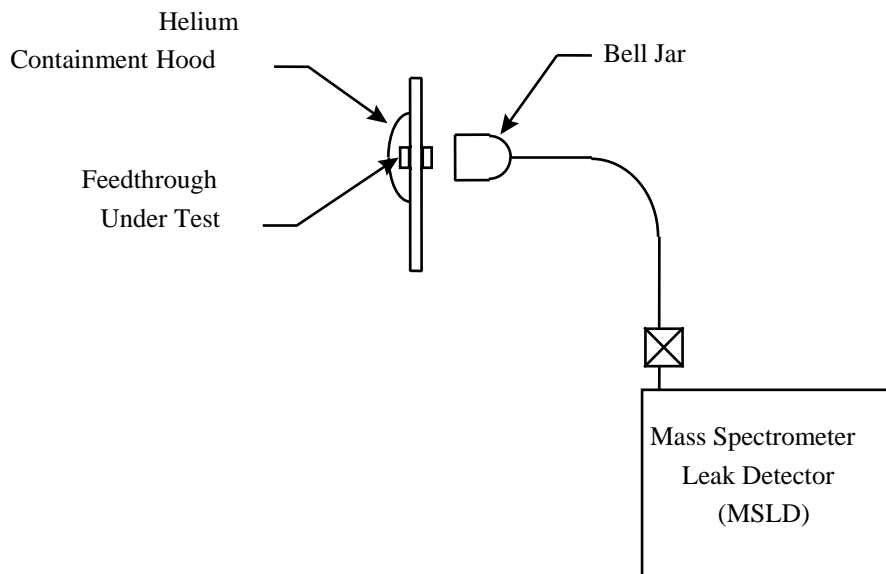

Figure 3: Feedthrough Leak Rate Testing

PLUMBING LEAK TESTING

Tubing and hoses in the International Space Station route fluid and gases throughout the Station. The U.S. Laboratory Module also has a Vacuum System which provides experiment racks with a space vacuum for experimentation and with an exhaust vacuum for venting unneeded gases. Plumbing internal to the modules is routed through the module standoffs and endcones and in the equipment racks. The plumbing was thoroughly leak tested as it was installed to ensure crew safety.

Leak testing of the vacuum system plumbing was performed on the pre-integrated standoffs prior to installation of the standoffs into the module, and then system level tests were performed following completion of the flight systems. The test method was a helium MSLD hood test and is illustrated in Figure 4 for one manifold of the Vacuum System. The manifolds under test were evacuated with an MSLD. A helium standard leak was connected to the rack location farthest from the MSLD; the leak was valved onto the manifold in order to determine the system sensitivity to a known helium leak. The joints in the manifold were bagged using plastic and tape and injected with helium one at a time. The seals in the vacuum system are metal gaskets, and each joint

had a leak rate requirement of $1\text{E-}8$ sccs helium.

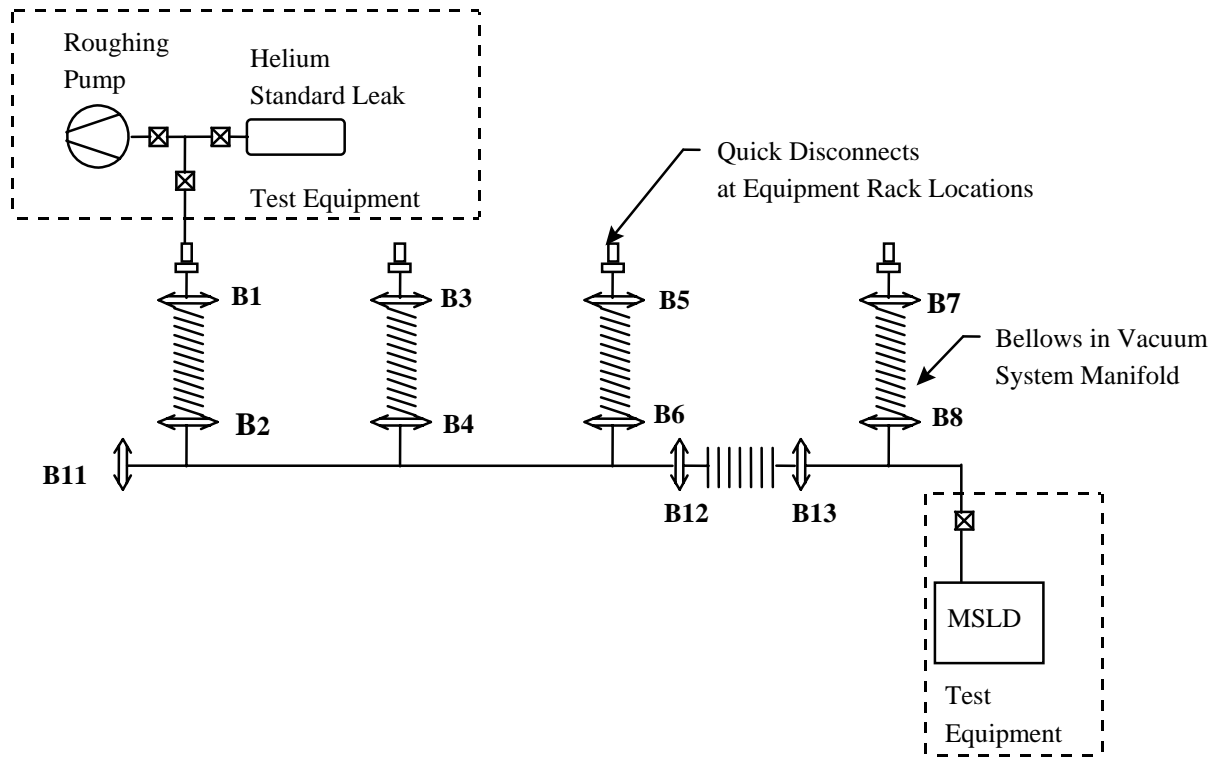

Figure 4: U.S. Laboratory Standoff Vacuum System Manifold Leak Test

Pressurized Plumbing Systems

ISS pressurized plumbing systems include the Thermal Control System which provides cooling water to the electronic hardware and Oxygen and Nitrogen Systems for air re-supply. Flex hoses and system components were acceptance tested by the vendor prior to delivery and installation. The installed plumbing was leak tested by pressurizing the systems with helium to maximum operating pressure and performing helium detector probe tests on the joints. A major challenge with the leak testing of the plumbing was the teflon-lined flex hoses that permeated helium, thus increasing the helium background levels during testing. High quality/purity air was used to purge the helium from the joints under test during sniffing. A helium leak sized slightly lower than the per joint requirement of $1\text{E-}4$ sccs helium was used to verify sensitivity before, during, and after testing of the flight joints.

COMMON BERTHING MECHANISM (CBM) LEAK TESTING

The CBM is used to join modules together in space. Each module port has a CBM bolted to it while on the ground, and this joint is referred to as the CBM-pressurized element, or CBM-PE joint. This joint contains two elastomeric O-rings, the inner one made of fluorocarbon and the outer of silicone. The ISS program has a requirement that all sealed joints that can leak to space must have two seals for redundancy. This requirement applies to joints that can be tested on the ground before launch. If a connection is made in space, then three seals are required. This is the case when two modules are mated on-orbit to comprise the CBM-CBM joint, which contains three seal beads. The CBM-CBM seals consist of four sections of silicone seals molded into an aluminum substrate. Figure 5 shows a cross section of a CBM with the CBM-PE and CBM-CBM seals installed.

CBM-PE Leak Testing

Leak testing of the CBM-PE seals is performed using the helium mass spectrometer hood method. All ISS seals greater than six inches in diameter were designed to accommodate leak testing with the incorporation of leak check ports which provide

access to the volume between the seals. Two leak check ports are included for every seal volume, and the ports are located one hundred and eighty (180) degrees apart.

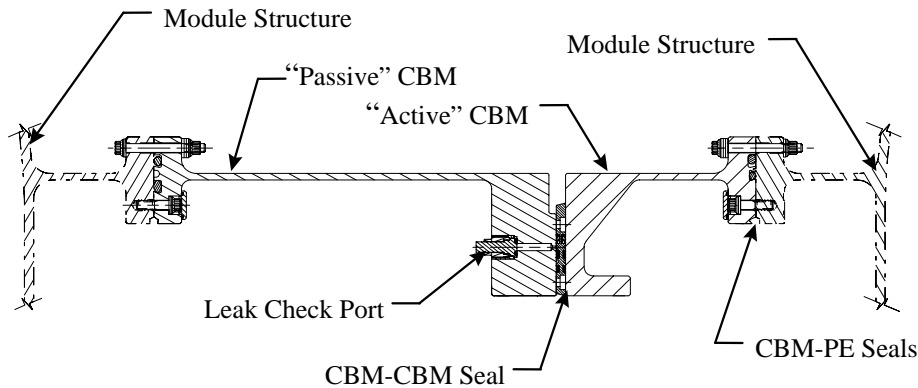

Figure 5: Common Berthing Mechanism Seals

The ports are fitted with leak check port adapters during leak testing, and are then plugged with “blind glands” following testing of the seals. Figure 6 shows the leak test setup for a CBM-PE joint. An MSLD is connected to one leak check port, and a three-valve manifold is connected to the other leak check port. The manifold is used with a roughing pump to evacuate the helium standard leak used to calibrate the test volume during the system calibration.

For the leak test, the volume between the seal beads is evacuated by the MSLD, then the system

calibration is performed during which a helium leak is introduced to the test volume and detected by the MSLD. After the MSLD is stable, the leak is valved off and the MSLD background returns to its original value. The system sensitivity is calculated and is later used to determine the seal leak rate.

Helium containment hoods are installed over the inner and outer CBM-PE joints. One of these hoods is then inflated with 100% helium until the MSLD is stable. The hood is then removed, and the MSLD background cleans up, and then the other hood is inflated to test the other seal.

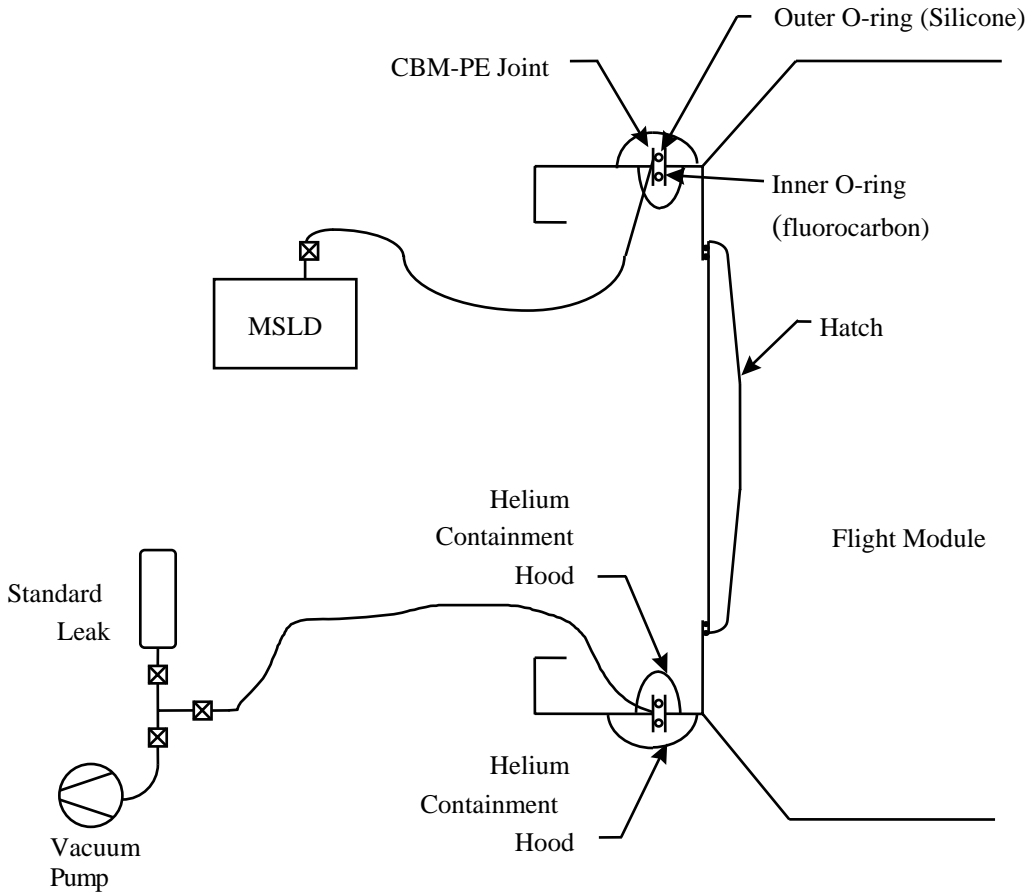

Figure 6: CBM-PE Seal Leak Testing

Blind Gland Leak Testing

Following the leak test of the CBM-PE seals, the blind glands are installed and leak tested. This test is critical because if a blind gland leaks, then the seal redundancy would be lost. First one of the leak test port adapters is removed and a blind gland is installed. The blind gland seals off the leak check port volume with a 1/16" diameter silicone seal that seats in the bottom of the leak check port hole. A helium containment hood is installed over the blind gland, and the volume between the seal beads is evacuated by the MSLD. The helium containment hood is injected with helium and the seal is allowed to permeate.

Following testing of the first blind gland installed, the volume between the seal beads, while still under a vacuum, is back-filled with 100% helium. The leak check port adapter is removed and the second blind gland is installed. The goal during this operation is

to leave the leak check port uncovered for as little time as possible to keep a 100% helium concentration in the volume. A test fixture connected to the MSLD is sealed over the blind gland and evacuated with the MSLD, and the blind gland leak rate is determined.

CBM-CBM Leak Testing

Leak tests of the CBM-CBM seals for Acceptance were not generally performed on the ground, as this joint will usually be made on-orbit. Node 1, however, was launched with two Pressurized Mating Adapters (PMAs) mated to it to provide berthing ports for the shuttle, and these CBM-CBM joints were tested prior to launch. The test procedure for the CBM-CBM seals is very similar to that used on the CBM-PE seals. Leak check ports provide access to the volumes between each of the three seal beads. MSLDs are used to evacuate the volume between the seal beads. System calibrations are performed on the volume between the outer and middle bead and on

the volume between the middle and inner bead. Helium containment hoods are installed over the outer and inner joint of the CBM-CBM to enable testing of the outer and inner seal beads. The only real difference in the CBM-CBM leak test conduct is that in order to test the middle seal bead, the seal volume between the middle and inner seals beads is used as the helium containment hood. This volume is evacuated and then back-filled with 100% helium to test the middle bead.

HATCH LEAK TESTING

Each ISS module includes at least one common Hatch, and the Node modules have six hatches each. When two modules are connected, the hatches between them will generally be open, however, for an unused port the Hatch is exposed to the vacuum of

space. See Figure 7 for an illustration of the Hatch; Figure 8 shows cross sections of the Hatch seals.

The aluminum Hatch seals to the module via a Perimeter Seal, a two-beaded silicone rubber molded seal with a stainless steel substrate. This seal is installed on the module bulkhead, and seals the outer perimeter of the Hatch when the Hatch is latched. Two leak check ports on the module bulkhead provide access to the volume between the two Perimeter Seal beads. These ports are located on opposite sides of the Hatch, and are used for leak testing the Perimeter Seals. The ports are plugged with blind glands during flight/orbit, and are replaced with test adapters for ground testing.

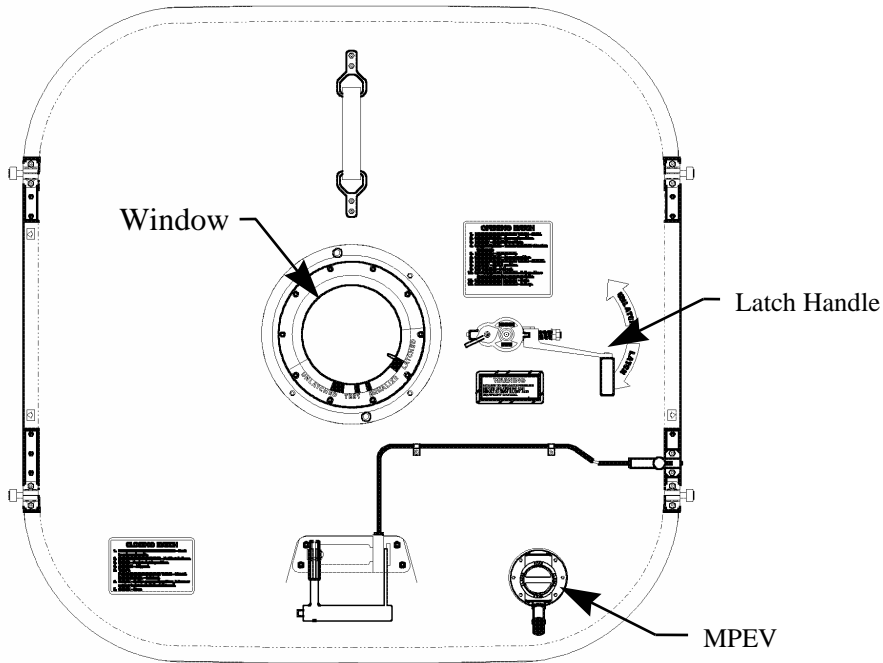

Hatch Internal View

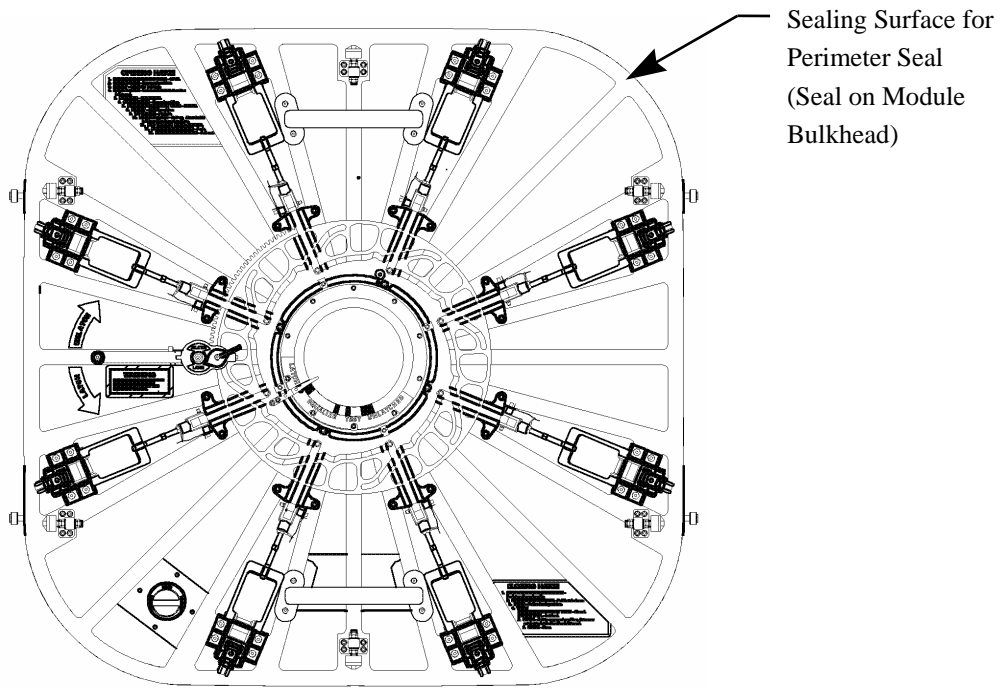

Hatch External View

Figure 7: International Space Station Hatch

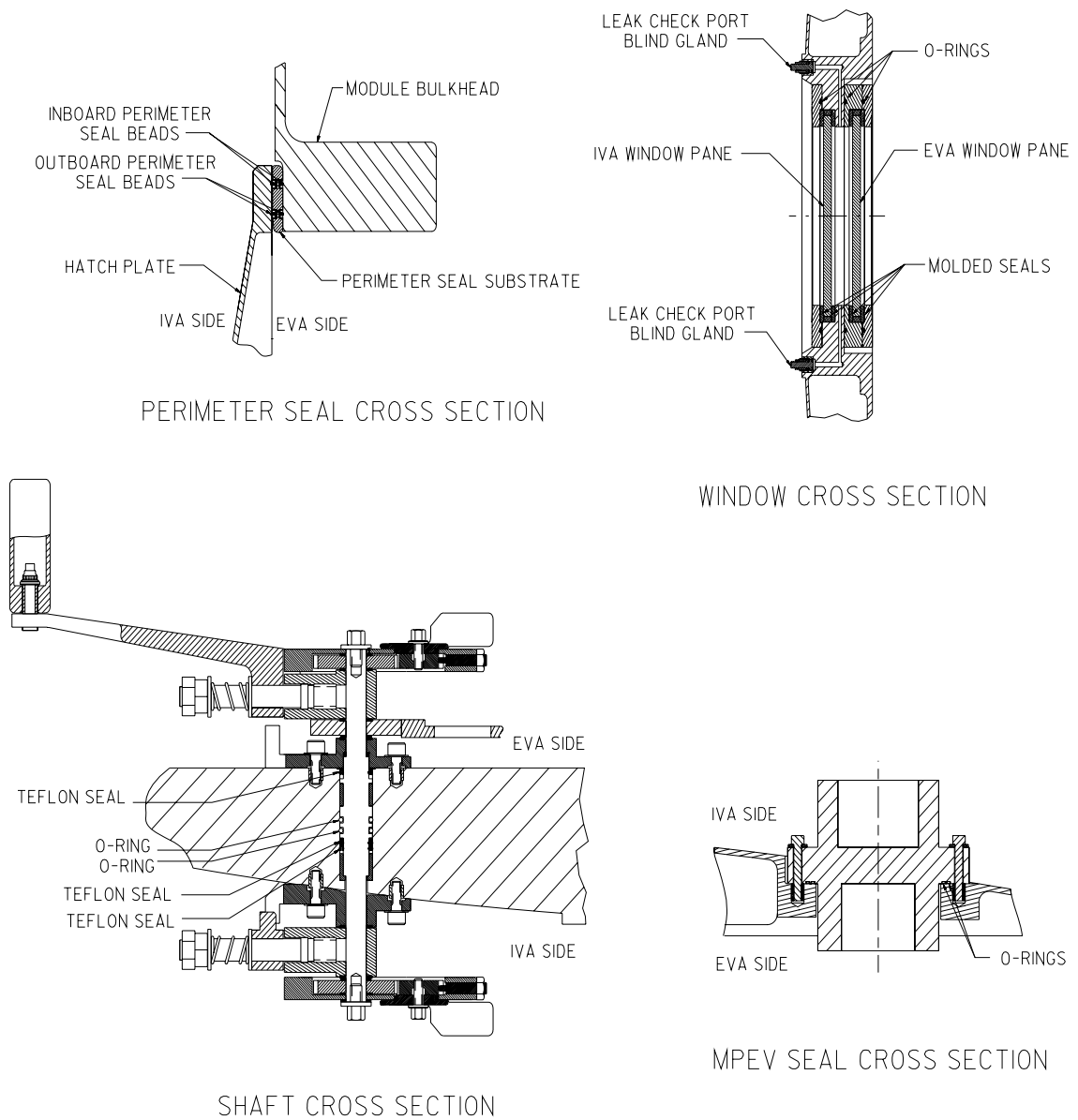

Figure 8: Hatch Seal Cross Sections

The Perimeter Seal is leak tested after a Hatch is installed to ensure a good installation, and then again following final closure of the Hatch before launch. The test setup for leak testing the Perimeter Seal is the same as for the CBM-PE seals, and is shown in

Figure 9. The leak rate requirement for the Perimeter Seal is $1E-2$ sccs helium per seal bead.

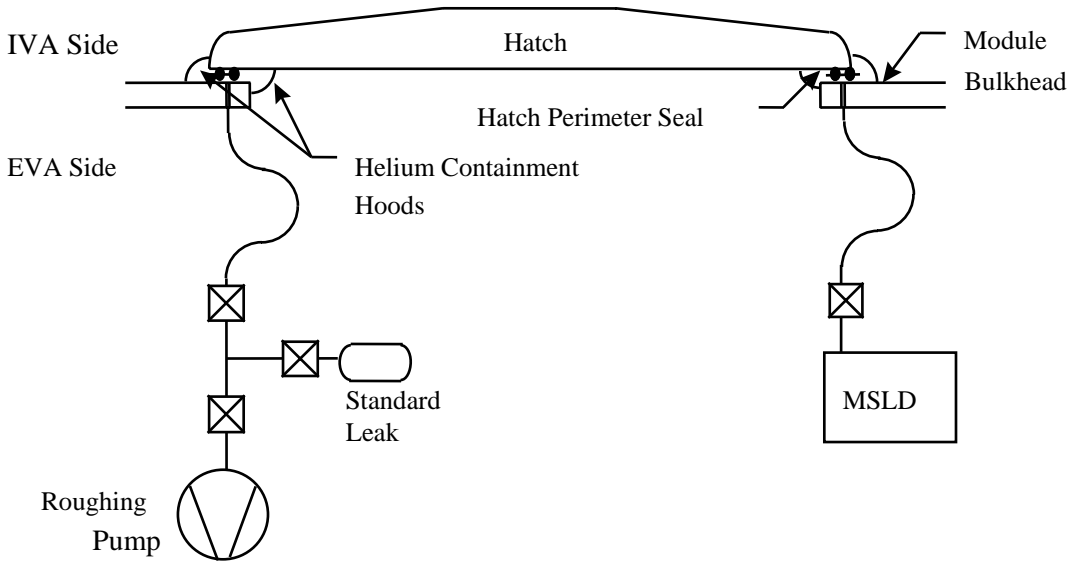

Figure 9: Hatch Perimeter Seal Leak Test Setup

The other Hatch seals, the Window seals, the Manual Pressure Equalization Valve (MPEV) seals, and the Shaft seals, are leak tested immediately following proof pressure of the Hatch prior to Hatch installation on the module. The Hatch has an eight-inch diameter double-paned window at its center. The window assemblies are sealed using silicone O-rings and one-beaded silicone rubber molded seals. The window has two Leak Check Ports located on the Window frame 180° apart. The MPEV is used to equalize pressure across the Hatch prior to use. It has two silicone O-rings in its flange. The Hatch Shaft runs through the Hatch plate and attaches to the handles that allow the Hatch to be opened from the inside or outside of the modules. The Shaft design incorporates two viton O-rings and three teflon seals.

For leak testing of the Window and Shaft Hatch seals, the Hatch is latched to an adapter plate which simulates the module bulkhead, and a pressure dome

closes out the hatch and is evacuated to provide the hatch with the same pressure deflections it would experience in space. This test setup is shown in Figure 10. An oil-free pump is used to evacuate the pressure dome, and an MSLD connected to the dome is brought on line to the dome volume. A helium standard leak is then valved onto the dome and the MSLD output is recorded until it is stable to determine the system sensitivity. A helium containment hood is installed over the shaft on the IVA side of the hatch, and is injected with helium until the MSLD is stable. This permeation of the shaft seals takes up to twelve hours because there are five seals in series on the shaft.

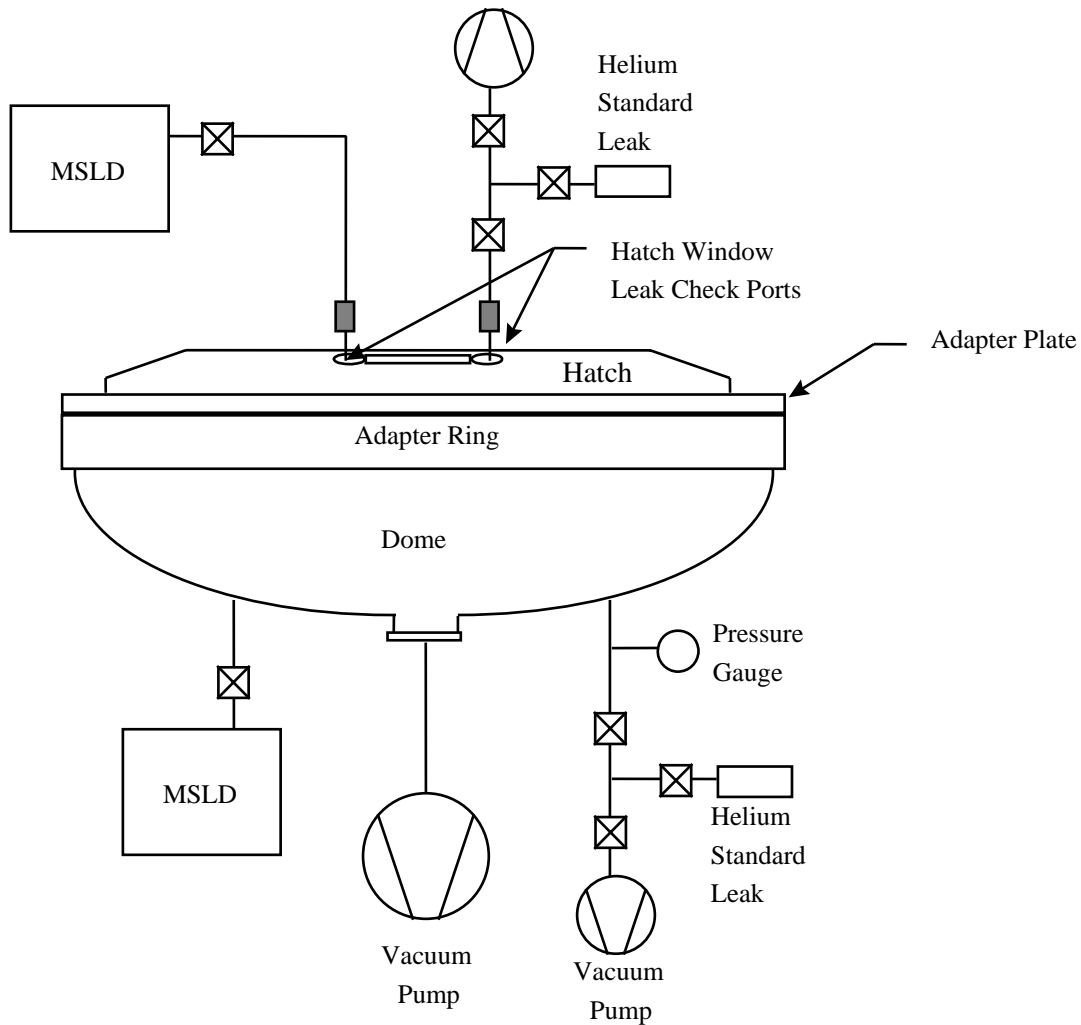

Figure 10: Hatch Window and Shaft Seal Acceptance Test Setup

The Hatch Window seals are tested next. The volume between the window panes is evacuated with an MSLD, and a calibration of the window volume is performed. The IVA side window is bagged and injected with helium, and the inboard window seals are permeated. For leak testing the EVA window seals, the volume between the panes is evacuated and back-filled with helium, which is then detected by the MSLD on the dome volume.

For testing of the MPEV seals, the EVA side of the MPEV is evacuated by a test fixture, or bell jar, connected to an MSLD. A helium containment hood is installed over the IVA side of the MPEV, and is injected with helium until the MPEV seals have permeated.

WINDOW LEAK TESTING

The U.S. Laboratory module contains a window with a 20" diameter viewing area. The window has several seals which require leak testing, as shown in the cross sectional view of Figure 11. Seals A and B seal the window's aluminum frame to the module structure. Leak check ports provide access to the volume between seals A and B for leak testing. These seals are tested in the same manner as the

Hatch perimeter seals. Seal C seals the two parts of the window frame together. Seals D and E seal the two glass panes to the window frame sections. Leak check ports provide access to the volume between the window panes in order to test seals C, D, and E. For tests of seals C and D, the volume between the window panes is evacuated with an MSLD, a system calibration is performed of the volume, and then helium containment hoods over the seal joints are injected one at a time. Seal E is tested by evacuation of a pressure cover installed over the EVA side of the

window with an MSLD. The volume between the window panes is evacuated and back-filled with helium to permeate the seal.

The window also contains a shaft that passes through the module and allows operation of the shutters over the window. The shaft contains five seals (three in parallel with two), and is tested like a module feedthrough with a bell jar installed over the exterior of the shaft.

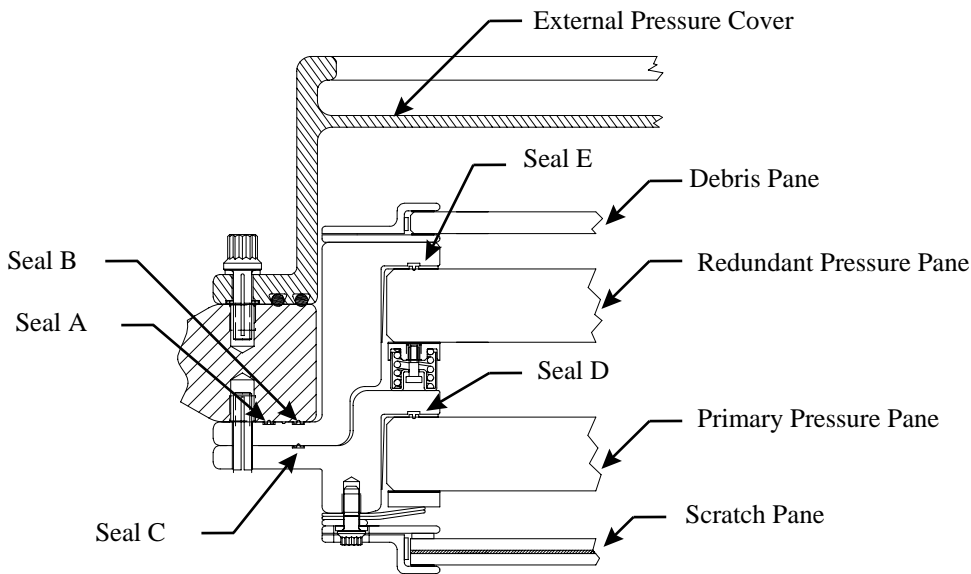

Figure 11: U.S. Laboratory Window Seals

MODULE ACCEPTANCE LEAK TESTING

Even though all leakage paths were tested as the ISS hardware was built up, module-level acceptance testing was required to verify the total element leak rate requirements. The module-level testing was performed at the Space Station Processing Facility at KSC.

Node 1 Accumulation Test

For the Node 1 module test, a helium accumulation test was performed in which the Node was placed in a Multiple Mission Support Equipment (MMSE) canister and pressurized to 14.7 psig with helium. Helium that leaked into the canister was measured by a gas chromatograph in parts per million. This test setup is shown in Figure 12. The test was performed in March

of 1998 in the Space Station Processing Facility at Kennedy Space Center.

Prior to pressurization of the Node with helium, three different standard helium leaks were introduced onto the canister volume to determine the test system sensitivity to known leakage. The leaks selected for the test provided helium flow rates which represented the overall Node makeup gas allocation, (1.5 sccs helium), and two smaller leaks of 0.23 sccs helium and 0.023 sccs helium. The Node 1 was fully outfitted for flight, except for one inter-module ventilation port feedthrough that had been removed and replaced with a penetration for the test plumbing. Test results are summarized in Figure 13. The values for the Node 1 pressurization with helium were adjusted for the 50% helium concentration in the module. Leakage was determined to be .005 pounds per day of air, which was 23 times below the leak rate requirement.

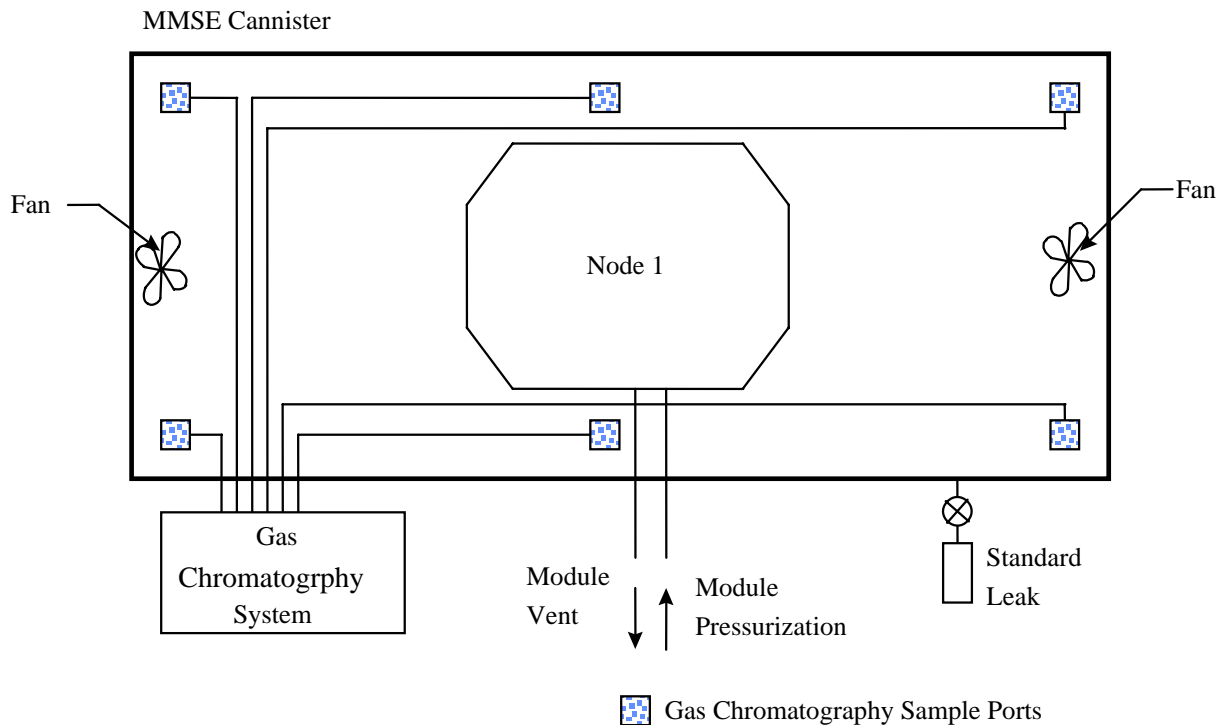

Figure 12: Node 1 Helium Accumulation Test

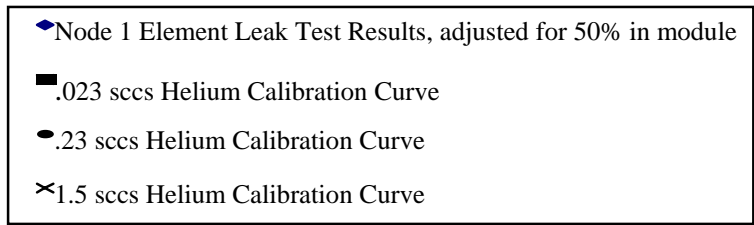
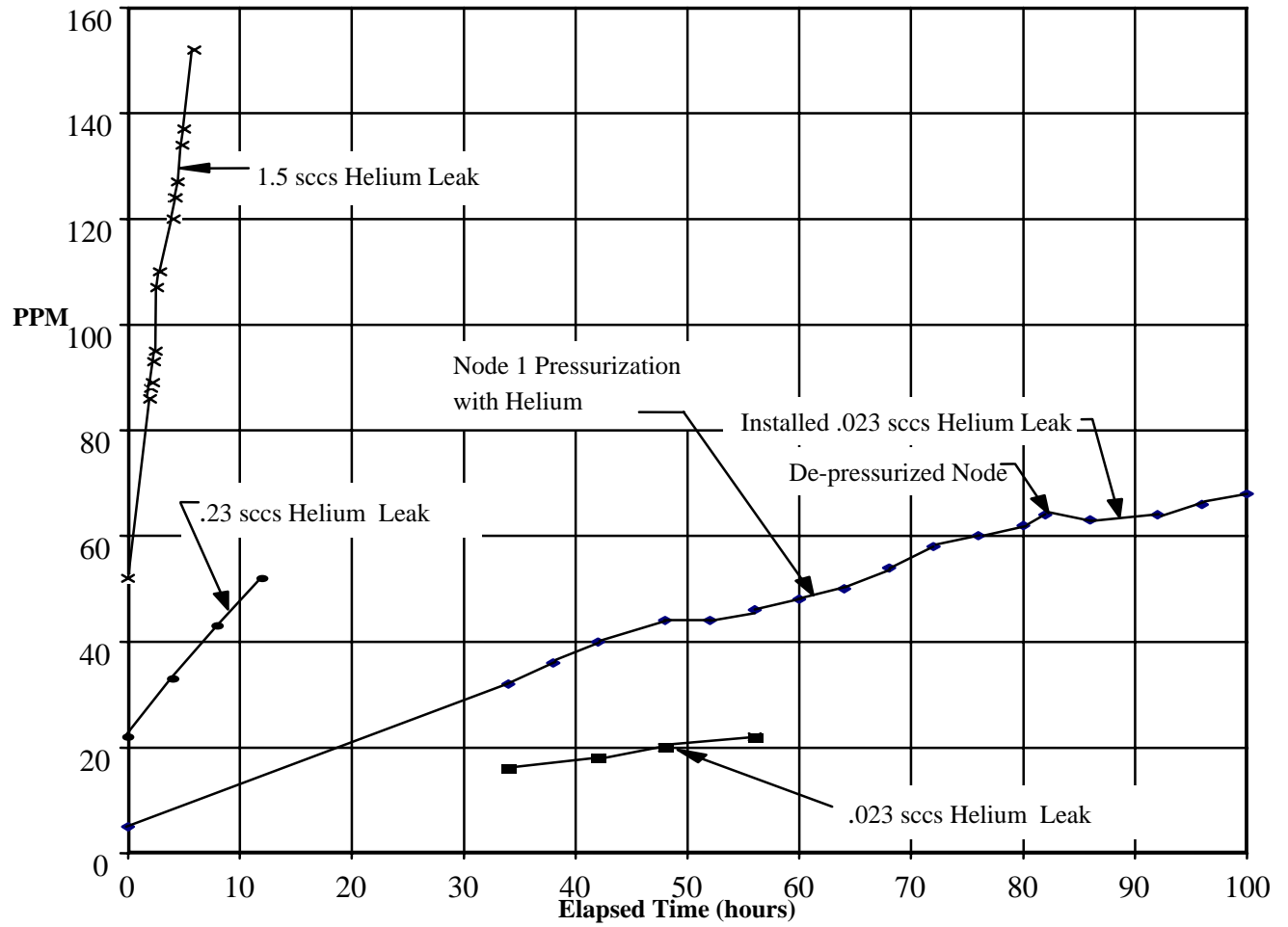

Figure 13: Node 1 Helium Accumulation Test Results

Lab/Airlock Vacuum Chamber Test

For module-level tests of the U.S. Laboratory Module and Airlock, the O & C vacuum chamber at KSC was re-activated and a vacuum chamber leak test will be performed in 1999. The chamber is a 48,000 cubic foot top-loaded chamber, 33 feet in diameter and 50 feet high. After the chamber is evacuated, the module will be purged with helium to

obtain a known helium concentration, and the leak rate will be measured by a helium mass spectrometer connected to the vacuum chamber. This test setup is shown in Figure 14. Before helium is introduced into the module under test, the chamber sensitivity will be determined by valving a known helium leak onto the chamber and monitoring the MSLD output. The chamber sensitivity will be used to calculate the total module leak rate.

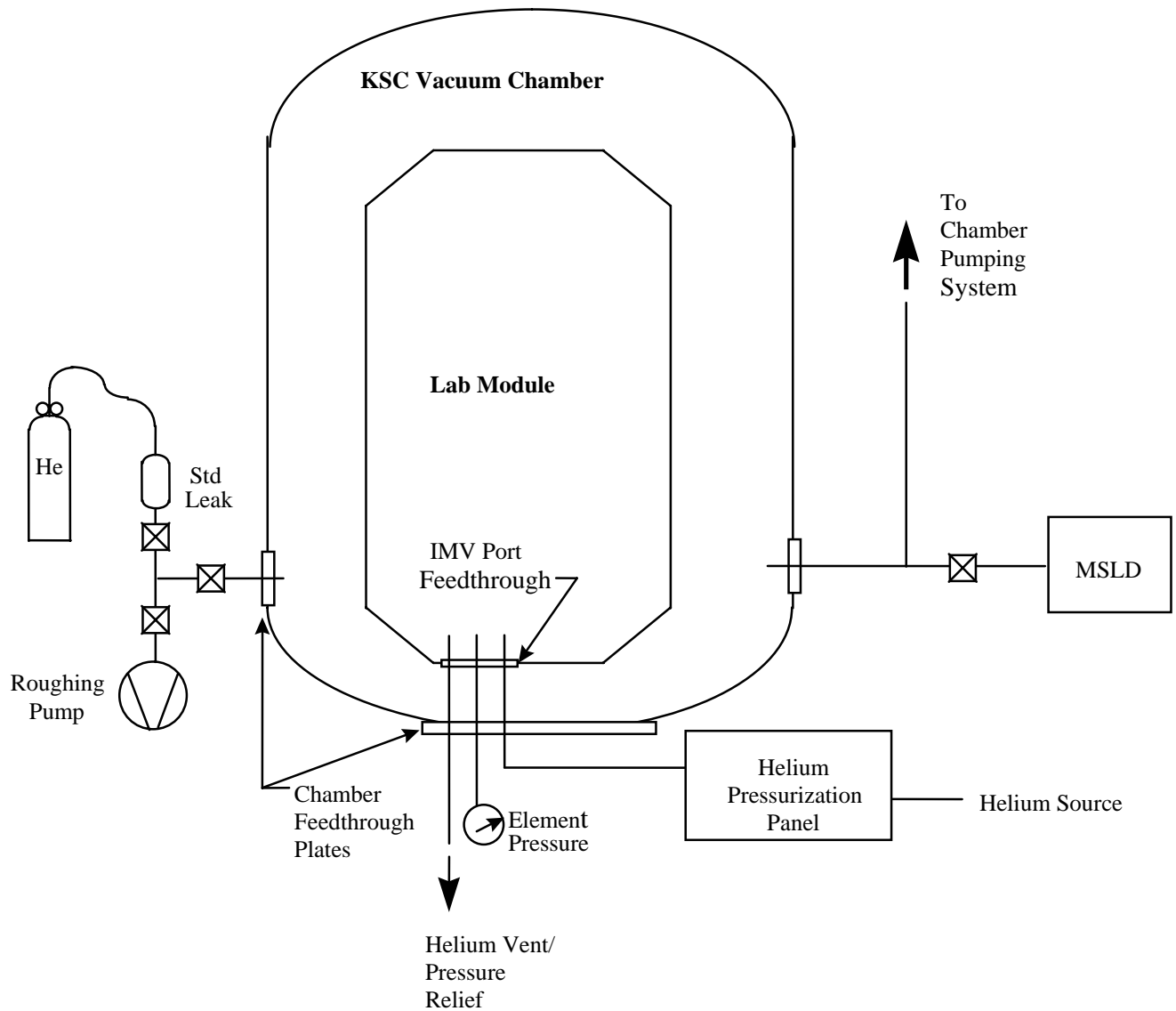

Figure 14: U.S. Laboratory Module Vacuum Chamber Test

FINAL MODULE CLOSEOUT

Following final processing of the flight modules prior to launch, the modules are closed out and a gross leak test is performed. This testing was performed on the Node 1 in September-October of 1998, and similar testing will be performed on the U.S. Laboratory and Airlock modules.

After the last Node 1 hatch was closed, there was no access to the interior of the module, so the normal test procedure for the IVA hatch seal bead - injecting helium in a helium containment hood over the IVA hatch joint - could not be performed. For this test, the EVA bead was tested as per usual, with an MSLD connected to the volume between the seal beads and a helium containment hood on the EVA side of the Hatch. With the MSLD still on line to the perimeter seal volume, the Node was pressurized with 3 psig of helium for a 40% helium concentration, and the IVA seal bead was permeated.

A gross pressure decay leak test was then performed with the Node pressurized at 3 psig for 24 hours. A flowmeter connected to the Node was opened to calibrate the test setup. The flowmeter had an air leakage value equivalent to the Node gross leak rate requirement of 0.05 psi/day. The Node module passed the gross leakage test. The criticality of the test was demonstrated by the discovery during Node pressurization of a valve inadvertently left in an open position.

CONCLUSIONS AND SUMMARY

Leak testing of the International Space Station modules was performed incrementally on the hardware as it was assembled. Leak rate requirements for acceptance of the hardware were based on the hardware capability, not the ISS re-supply gas availability, in order to ensure defect-free workmanship. All leak tests utilized helium standard leaks sized at or below the leak rate requirement and calibrations of the test systems were performed in order to obtain quantitative leak rates. In all cases, developmental testing was performed prior to the acceptance testing of hardware to validate the leak test processes and procedures.

.

REFERENCES

1. S. Underwood and A. Holt, "Structural Weld Leak Testing in Support of the International Space Station Node 1, Airlock, and Laboratory Flight Elements", 20th Space Simulation Conference, NASA/CR-1998-208598
2. S. Underwood and A. Holt, "Verification of International Space Station Redundant Seals by Analysis of Helium Permeation Data", 18th Aerospace Testing Seminar, 1998 (Paper of this compilation)
3. A. Holt and S. Underwood, "Leak Rate Testing of the International Space Station Hatch in a Thermal Vacuum Environment", 20th Space Simulation Conference, NASA/CR-1998-208598
4. S. Underwood and A. Holt, "International Space Station Node 1 Helium Accumulation Leak Rate Test", 20th Space Simulation Conference, NASA/CR-1998-208598