

A Microfabricated Involute-Foil Regenerator for Stirling Engines by

**Roy Tew, NASA Glenn Research Center
Mounir Ibrahim and Daniel Danila, Cleveland State University
Terry Simon, Susan Mantell and Liyong Sun, U. of Minnesota
David Gedeon, Gedeon Associates
Kevin Kelly and Jeffrey McLean, International Mezzo Technologies
Gary Wood, Sunpower Inc.
Songgang Qiu, Infinia**

**Presented by Roy Tew for IECEC 2007
June 25-27, 2007, St. Louis, MO**

[Abstract] A segmented involute-foil regenerator has been designed, microfabricated and tested in an oscillating-flow rig with excellent results. During the Phase I effort, several approximations of parallel-plate regenerator geometry were chosen as potential candidates for a new microfabrication concept. Potential manufacturers and processes were surveyed. The selected concept consisted of stacked segmented-involute-foil disks (or annular portions of disks), originally to be microfabricated from stainless-steel via the LiGA (lithography, electroplating, and molding) process and EDM (electric discharge machining). During Phase II, re-planning of the effort led to test plans based on nickel disks, microfabricated via the LiGA process, only. A stack of nickel segmented-involute-foil disks was tested in an oscillating-flow test rig. These test results yielded a performance figure of merit (roughly the ratio of heat transfer to pressure drop) of about twice that of the 90% random fiber currently used in small ~ 100 W Stirling space-power convertors—in the Reynolds Number range of interest (50-100). A Phase III effort is now underway to fabricate and test a segmented-involute-foil regenerator in a Stirling convertor. Though funding limitations prevent optimization of the Stirling engine geometry for use with this regenerator, the Sage computer code will be used to help evaluate the engine test results. Previous Sage Stirling model projections have indicated that a segmented-involute-foil regenerator is capable of improving the performance of an optimized involute-foil engine by 6-9%; it is also anticipated that such involute-foil geometries will be more reliable and easier to manufacture with tight-tolerance characteristics, than random-fiber or wire-screen regenerators.

Beyond the near-term Phase III regenerator fabrication and engine testing, other goals are (1) fabrication from a material suitable for high temperature Stirling operation (up to 850 C for current engines; up to 1200 C for a potential engine-cooler for a Venus mission), and (2) reduction of the cost of the fabrication process to make it more suitable for terrestrial applications of segmented involute foils. Past attempts have been made to use wrapped foils to approximate the large theoretical figures of merit projected for parallel plates. Such metal wrapped foils have never proved very successful, apparently due to the difficulties of fabricating wrapped-foils with uniform gaps and maintaining the gaps under the stress of time-varying temperature gradients during start-up and shut-down, and relatively-steady temperature gradients during normal operation. In contrast, stacks of involute-foil disks, with each disk consisting of multiple involute-foil segments held between concentric circular ribs, have relatively robust structures. The oscillating-flow rig tests of the segmented-involute-foil regenerator have demonstrated a shift in regenerator performance strongly in the direction of the theoretical performance of ideal parallel-plate regenerators.

A Microfabricated Involute-Foil Regenerator for Stirling Engines

by

Roy Tew, NASA Glenn Research Center

Mounir Ibrahim and Daniel Danila, Cleveland State University

Terry Simon, Susan Mantell and Liyong Sun, U. of Minnesota

David Gedeon, Gedeon Associates

Kevin Kelly and Jeffrey McLean, International Mezzo Technologies

Gary Wood, Sunpower Inc.

Songgang Qiu, Infinia

Presented by Roy Tew

for

IECEC 2007

June 25-27, 2007

St. Louis, MO

Glenn Research Center

at Lewis Field



Acknowledgments

The work described in this paper was performed for the NASA Science Mission Directorate (SMD) and the Radioisotope Power System (RPS) Program. Any opinions, findings and conclusions or recommendations expressed in this report, are those of the authors and do not necessarily reflect the views of the National Aeronautics and Space Administration.

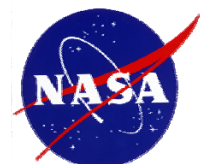

Background/Summary

- **A NASA Research Award (NRA) contract was awarded to define, develop and test an improved regenerator for Stirling engines**
- **Award went to Cleveland State U. and subcontractors: U. of Minnesota, Gedeon Associates, Sunpower Inc. and Infinia Corp.**
- **Phase I: Reviewed potential geometries, microfab. processes & manufacturers (chose involute-foil & Int. Mezzo Technologies)**
- **Phase II: Fabricated a nickel segmented-involute-foil regenerator via LiGA and tested it in the NASA/Sunpower oscillating-flow test rig (Excellent Results—Figure-of-Merit ~ 2 X that of current 90% porosity random fiber)**
- **Phase III: Fab. & testing an involute-foil regenerator in a Sunpower FTB (Frequency Test Bed) convertor (underway)**

Glenn Research Center

at Lewis Field

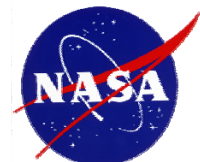

Problems with Random Fiber & Wire Screen Regenerators & Idea for Improving Detailed Structure of Regenerator

- **Have, primarily, cross-flow across wires with resulting excellent heat transfer but large pressure drop & increased thermal dispersion (enhanced conduction) due to resulting wakes, eddies & stagnation zones downstream of wires.**
- **Also: Random contact areas between wires makes breakage more likely when compressed to adjust porosity**
- **And: Random variations in wire locations mean porosity varies somewhat from region to region of the regenerator volume**
- **Idea—Use a microfabrication process to develop a precisely defined (non-random) geometry that significantly reduces pressure drop losses while maintaining good heat transfer—and improves reliability and uniformity of porosity**



Some Concepts Considered

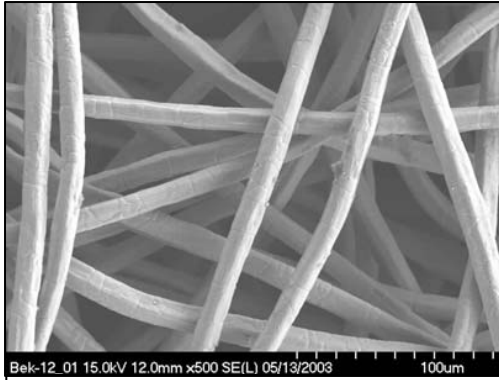

Random Fiber—with Flow Primarily Across Wires

Lenticular Concept. Two-Dimensional Representation with CFD Calculated Velocity Contours. Constant Velocity Input at Left

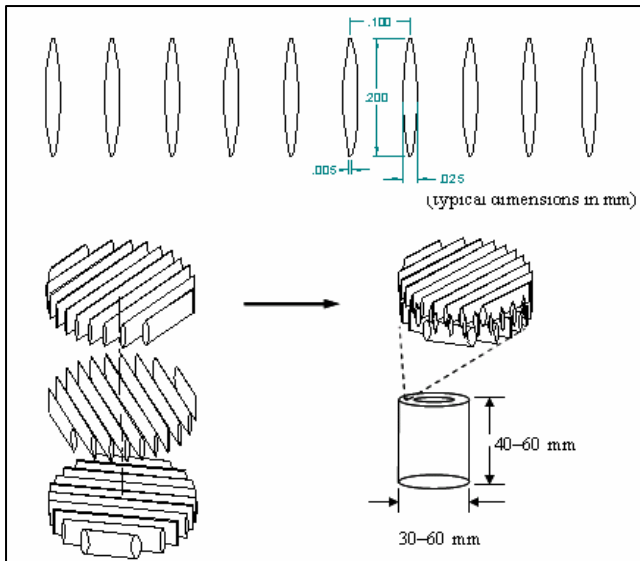
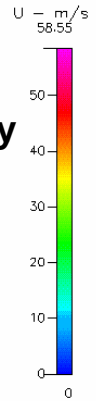
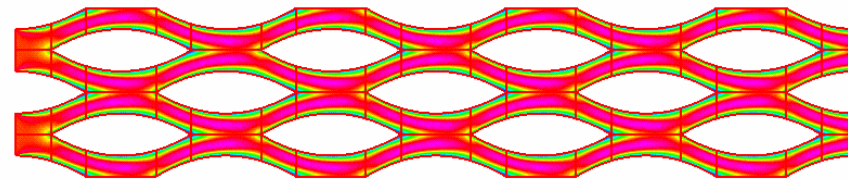

More Practical Lenticular?

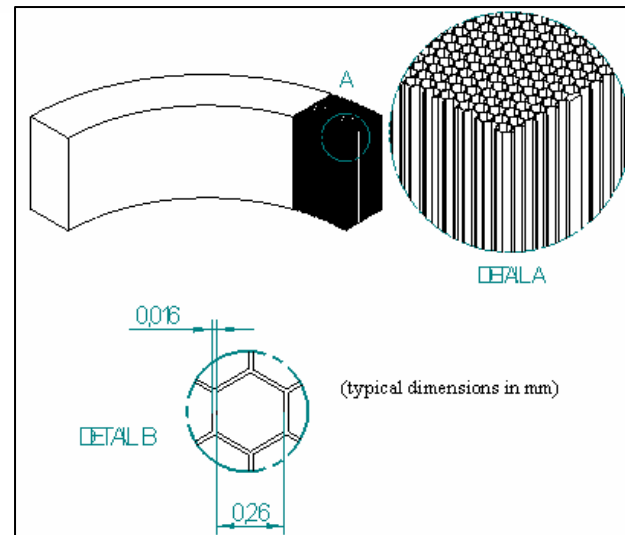

Honeycomb Array. Mezzo has made these out of erbium for coolers—at relatively low porosities

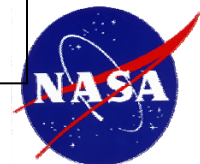

Figure of Merit: Definition, Comparisons for Previous Concepts & Theoretical Parallel Plates

$$F_M = \frac{1}{f \left(\frac{R_e P_r}{4N_u} + \frac{N_k}{R_e P_r} \right)}$$

R_e Reynolds number

P_r Prandtl number

f Friction factor

N_u Nusselt number

N_k Thermal dispersion conduction enhancement

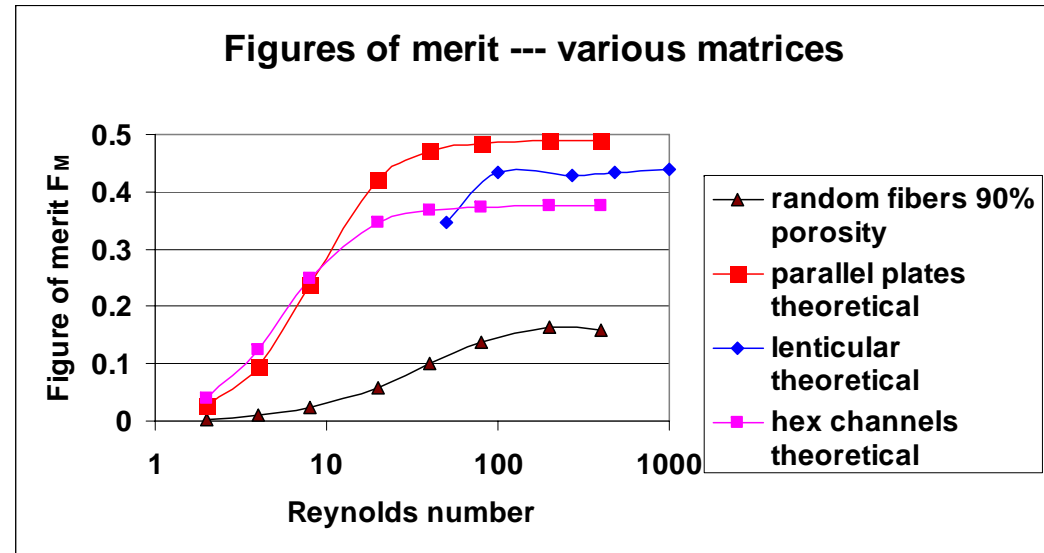

- The above figure-of-merit is a modification of the “traditional” figure-of-merit (a ratio of heat transfer to pressure drop) by Gedeon—to include thermal-dispersion conduction enhancement.
- The above figure-of-merit comparisons with theoretical parallel-plates are based on calculations using Gedeon Associates’ Sage code & random fiber oscillating-flow rig data.

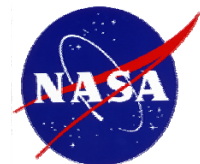

Original Involute-Foil Approximations to Parallel-Plate Geometry

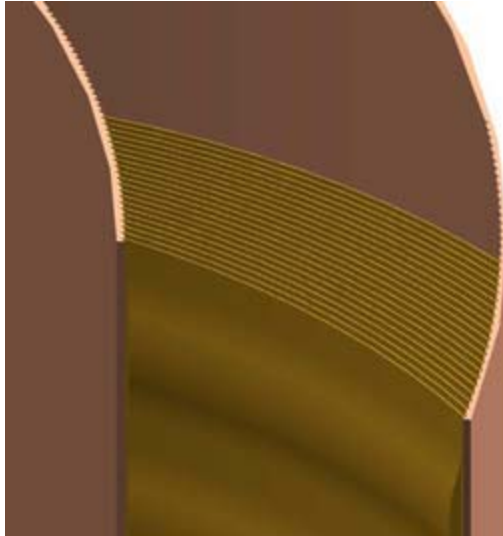

- Curved involute-foils—subjected to thermal expansion—change curvature slightly in a regular way to accommodate new arc length.
- Flat plates buckle in random directions & wrapped-foils expand in non-regular ways, producing very non-uniform flow gaps—when subjected to thermal expansion.
- But— could find no manufacturer for this relatively-long involute-foil geometry

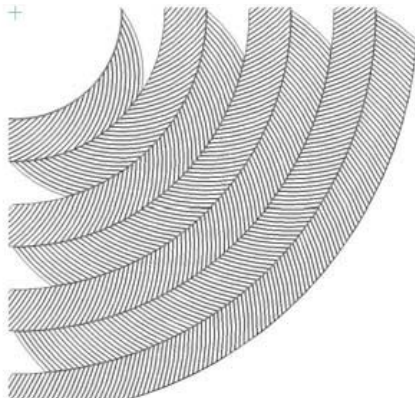

Axial View

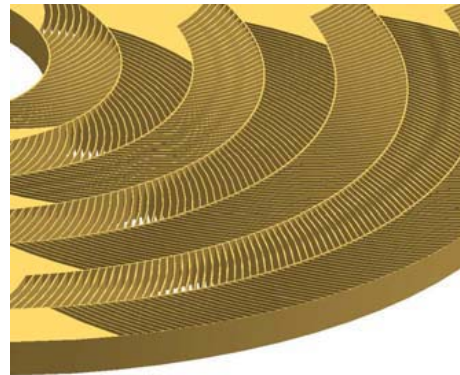

Solid Model of One Annulus

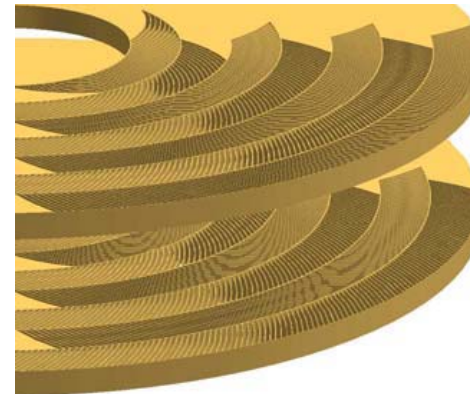

Two Annuli—Identically Manufactured But Adjacent Annuli are Flipped

First
Segmented
Involute-Foil
Concept



Chosen Segmented-Involute-Foil Concept, for Microfabrication and Testing

- **Very Similar to Original Segmented Involute-Foil, Except:**
 - Radial Segments between Rings All Tilt in Same Direction
 - Rings (or Ribs) in Adjacent Annuli Are Now Offset
 - Adjacent Annuli Are Still “Flipped” So That Radial Segments in Adjacent Annuli Cross at $\sim 90^\circ$ Angle

UMN Large-Scale Mock Up of Sectors of Annuli

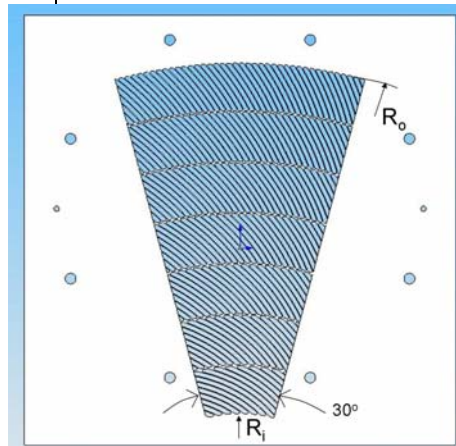

Six-Ring (or Rib) Pattern

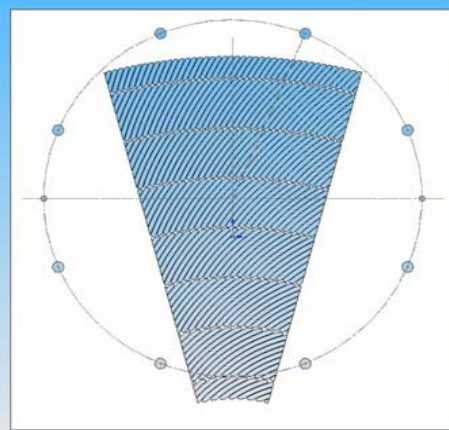

Seven-Ring Pattern

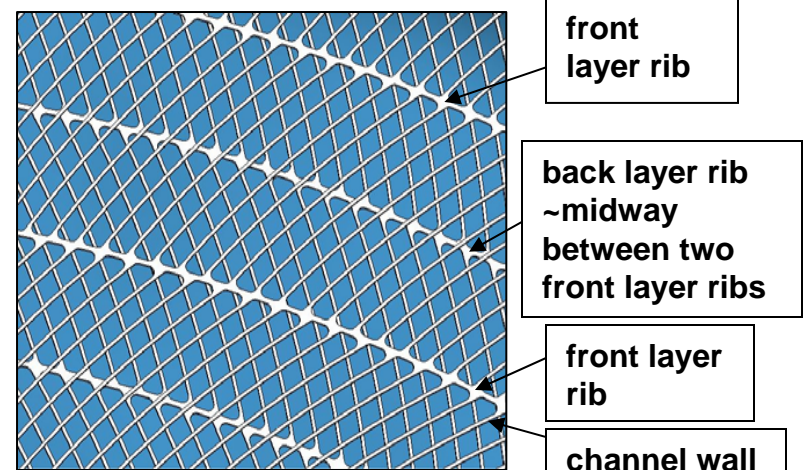

Frontal View Showing Two Layers of Segmented Involute Foil

Glenn Research Center

at Lewis Field



Involute-Foil Oscillating-Flow-Rig Test Results

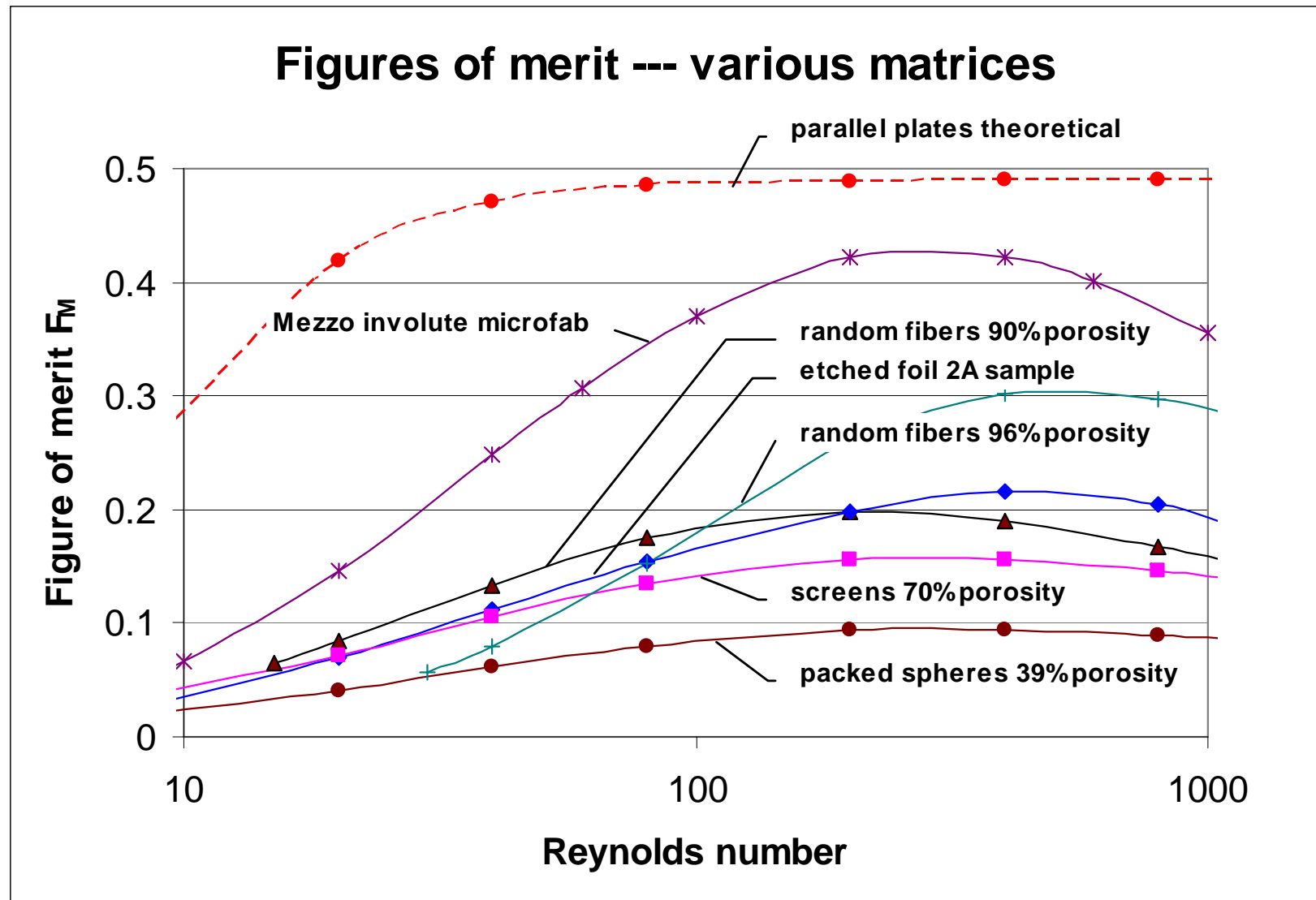

Mezzo Microfabrication Process—Evolution, and Steps

- Originally planned to microfabricate stainless-steel involute foil regenerator via LiGA and EDM
- Large EDM burn times led to decision to microfabricate a prototype nickel involute-foil regenerator via LiGA, only
- ~LiGA steps:
 - Fabricate x-ray mask
 - Bond PMMA photoresist to stainless-steel (SS) substrate
 - Expose PMMA via x-radiation through mask
 - Dissolve exposed volumes
 - Electroplate nickel into “dissolved volumes” onto SS substrate
 - Wire-EDM “overplated” and “undercut” regions on the two sides of the disk (Correction of microfab. imperfections)
 - Dissolve remaining PMMA to yield finished disk (annulus)

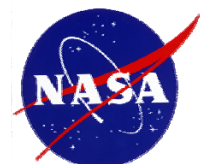

Different Magnifications of Views of An Involute-Foil Disk Annulus and The Oscillating-Flow-Rig Test Fixture

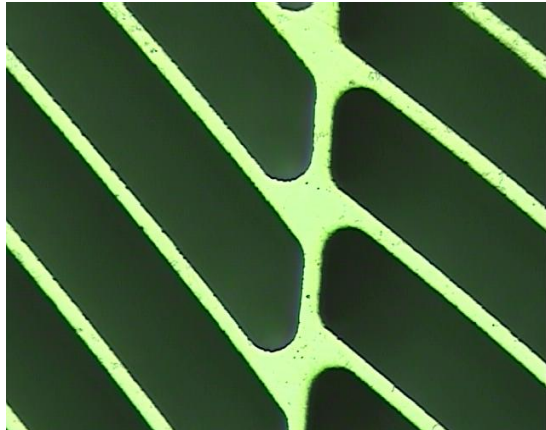

Nickel Involute Foils and Separating Ring (or Rib)



Lower Magnification of Inv. Foils, and Separating Rings



Disk Stacked on Fixture



Disk Leaning Against Outer Fixture Housing



Assembled Oscillating-Flow-Rig Test Fixture (Stack of 42 Disks)

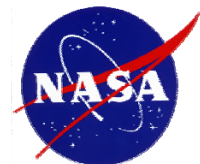

Involute Foil Channel Dimensions

(Channel Width is Average of the Different Channel Widths)

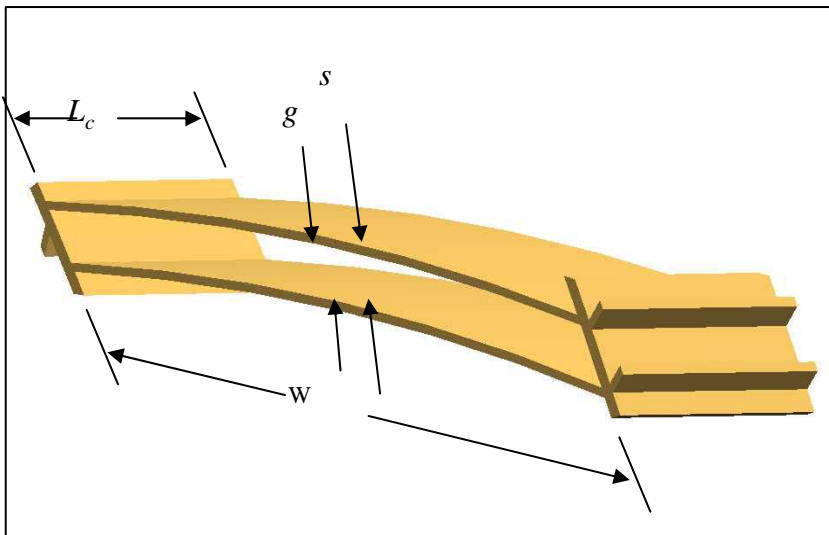

Dimension	Unit	Value
gap, g	micron, 10^{-6} m	86
gap+wall, s	micron	100
Wall thickness, $s-g$	micron	14
Channel width, W	micron	1000
disk (layer) thickness, L_c	micron	265
porosity		0.838
Hydraulic diameter, D_h , $4A/P$	micron	162

U. of Minnesota Large-Scale (30 X) Mock Up Tests



UMN Scotch-Yoke Oscillatory-Flow Generator

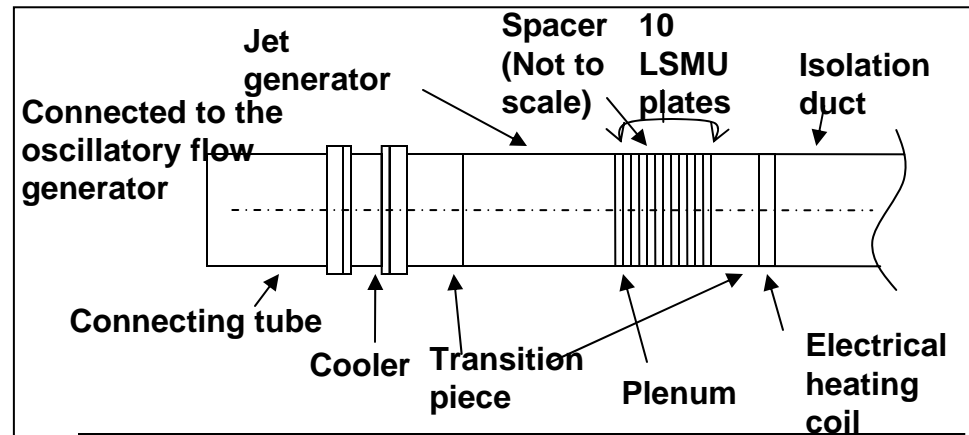

UMN Involute-Foil Oscillating-Flow Test Section

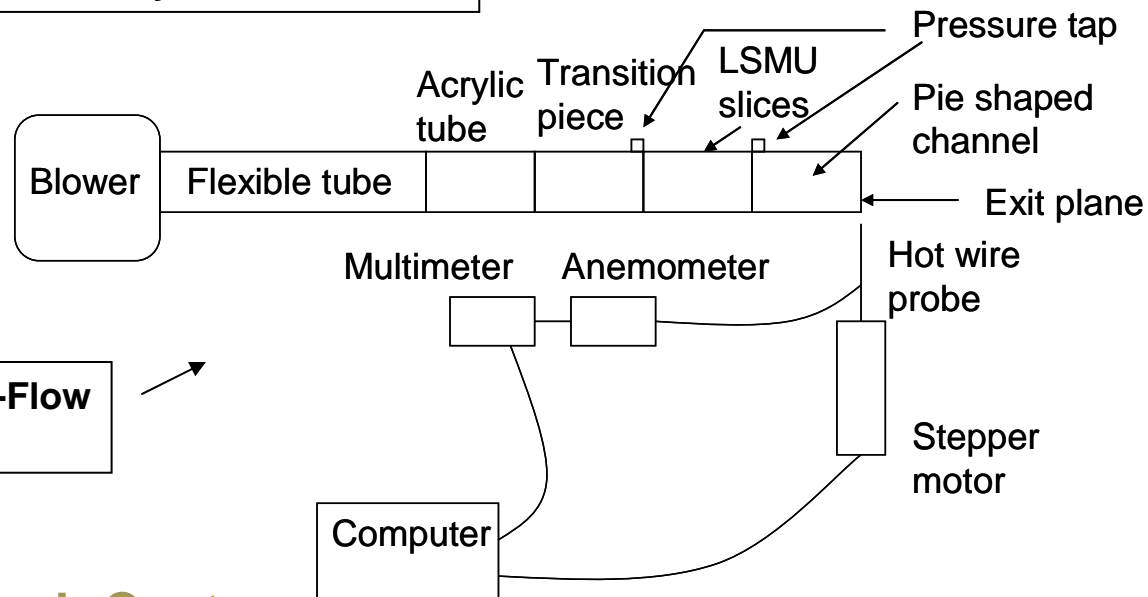

Unidirectional-Flow Test Setup



U. of Minnesota LSMU Friction-Factor Measurements-1

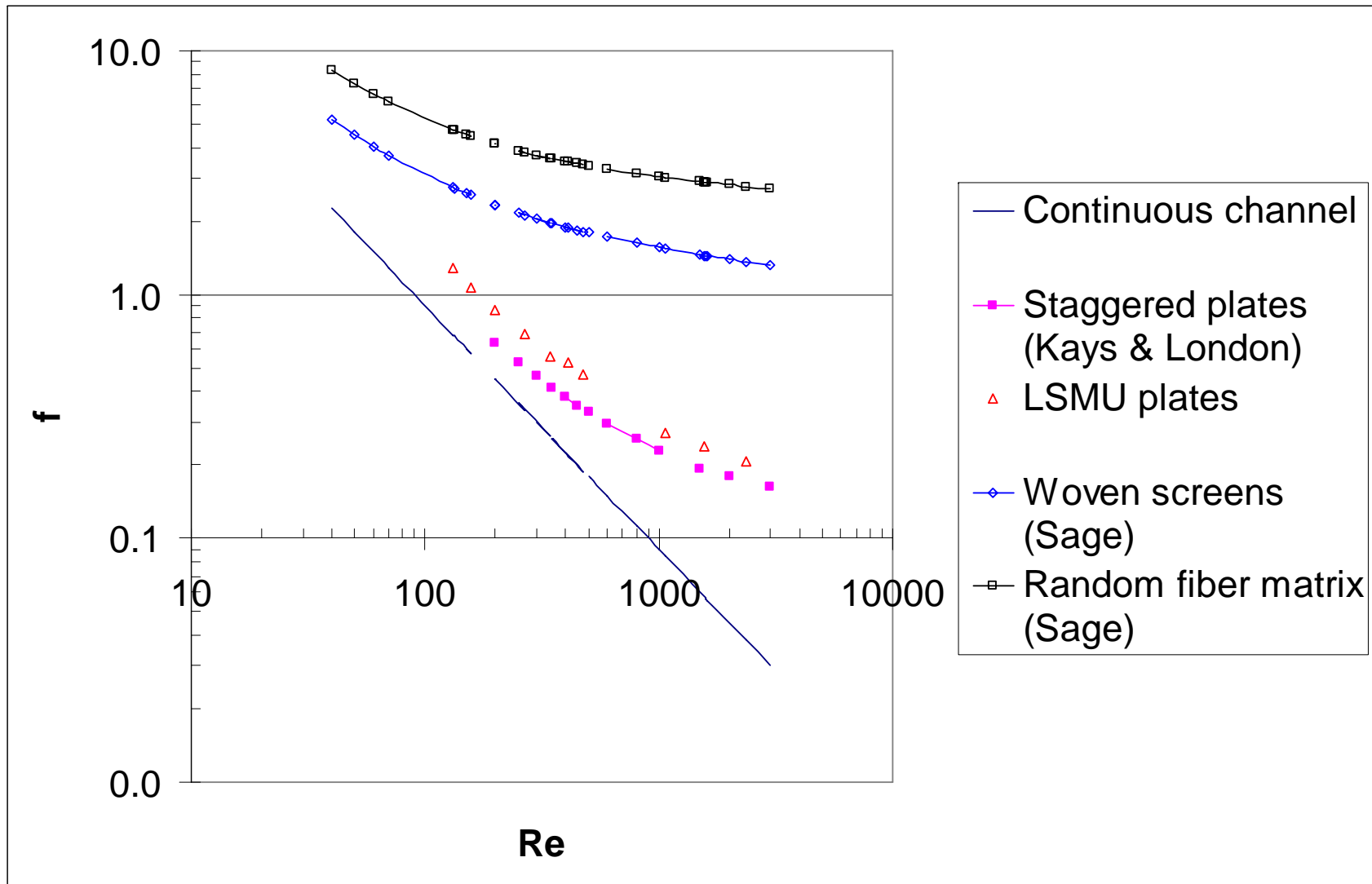

U. of Minnesota LSMU Friction-Factor Measurements-2

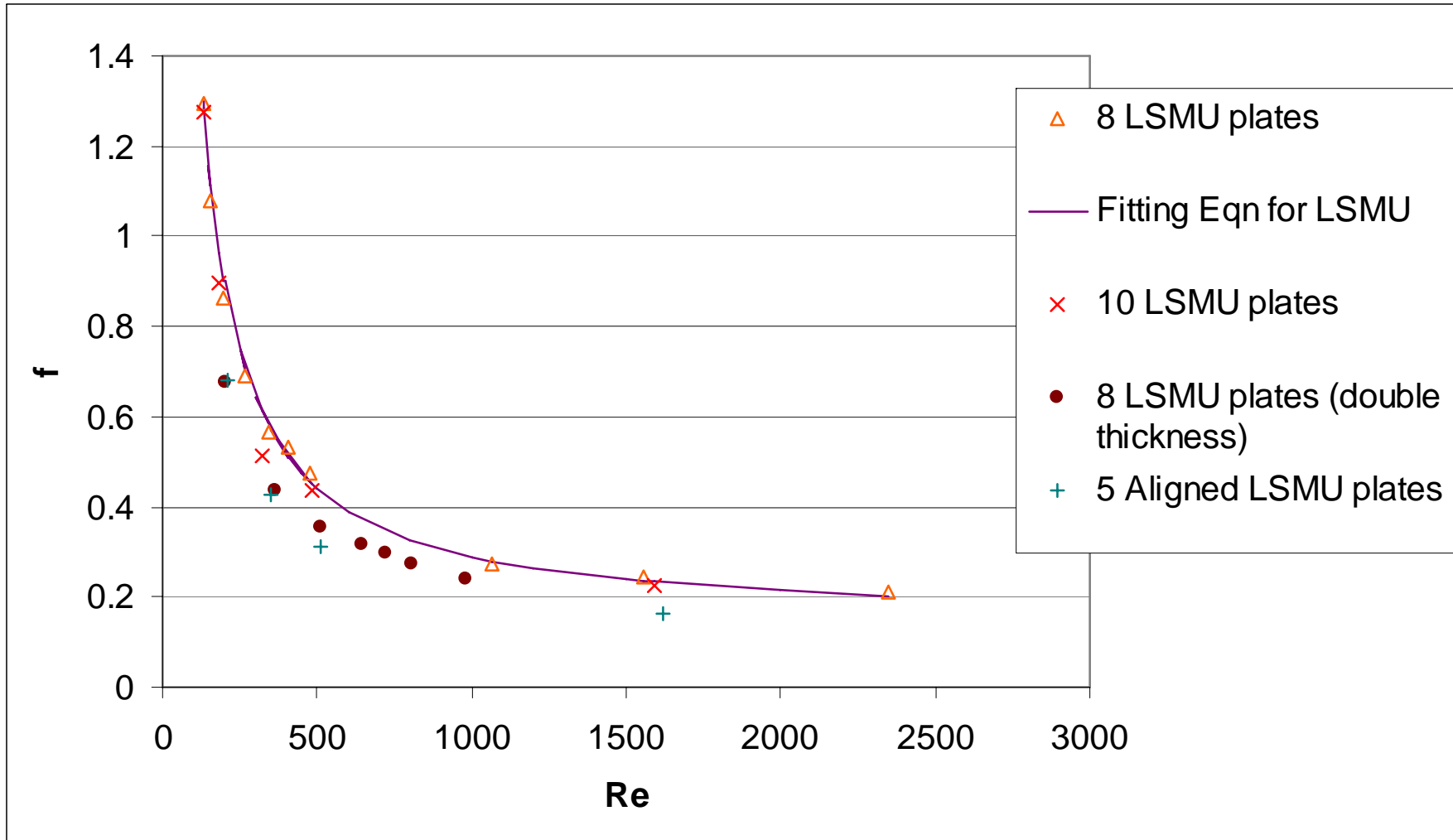

Cleveland State University 2-D CFD Simulations

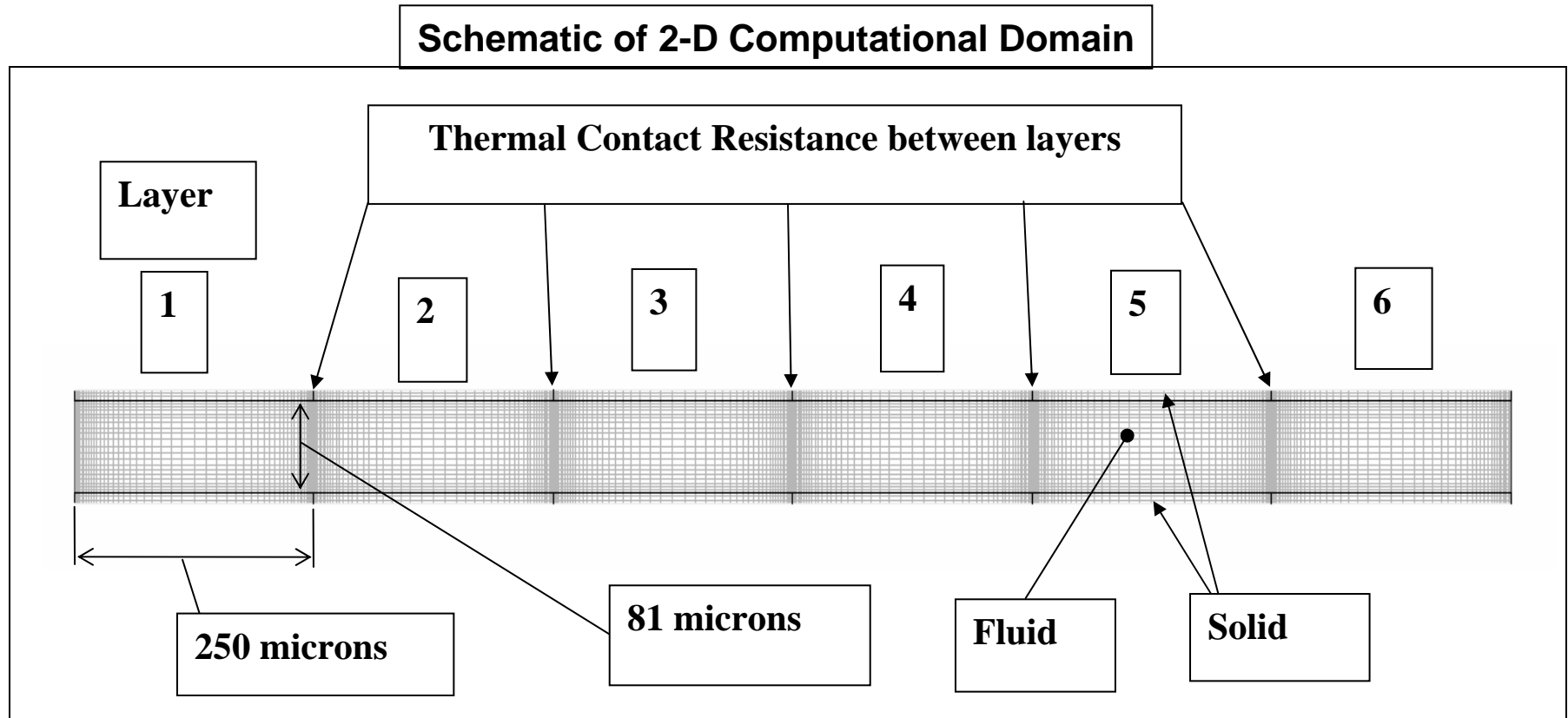

- The 2-D simulations were suitable for grid-independence studies and initial looks at the effects of thermal contact resistance between layers and use of different materials (e.g., stainless steel and nickel)

Cleveland State University 3-D CFD Simulations (6 layers were simulated)

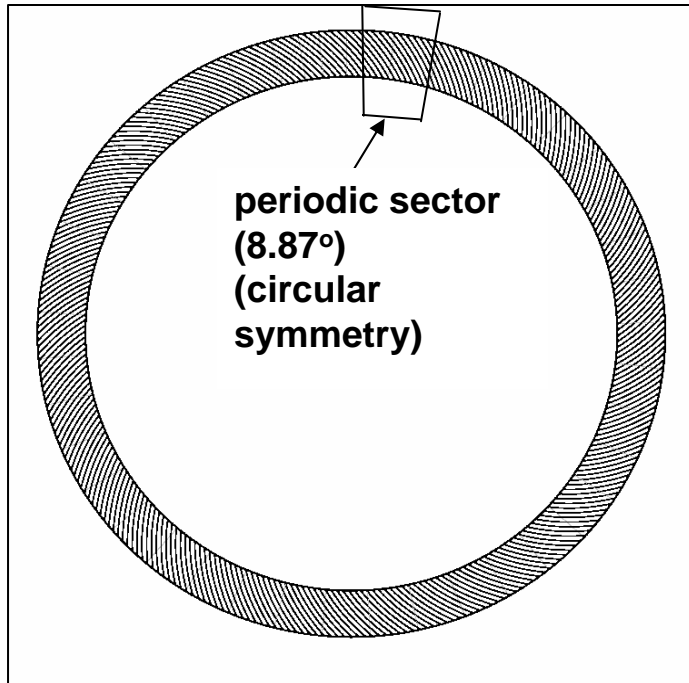

Ring of channels in "radial middle" and a sector from that ring

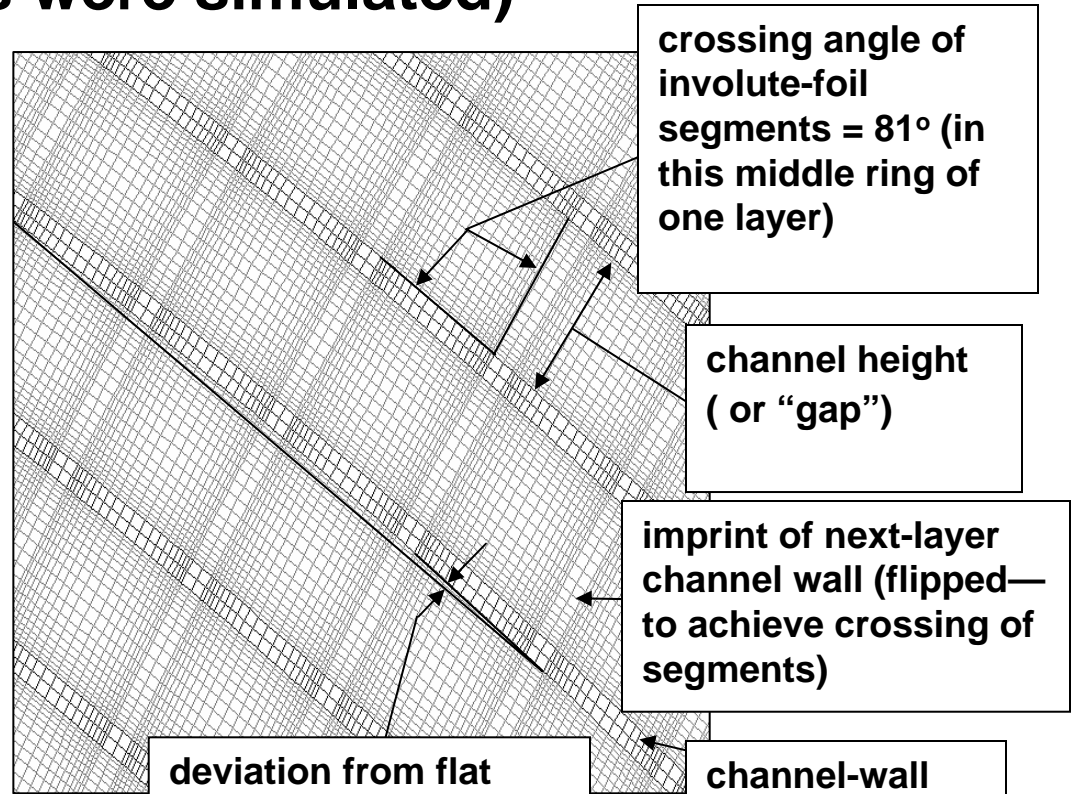

Enlarged area from middle of periodic sector—two layers of involute foils with grids—basis of simplifications for straight-channel-layer approx.



Mean Nusselt Numbers from 2-D & 3-D CFD Simulations & Empirical, Stephan (1959), Correlation (for Re. No. = 50)

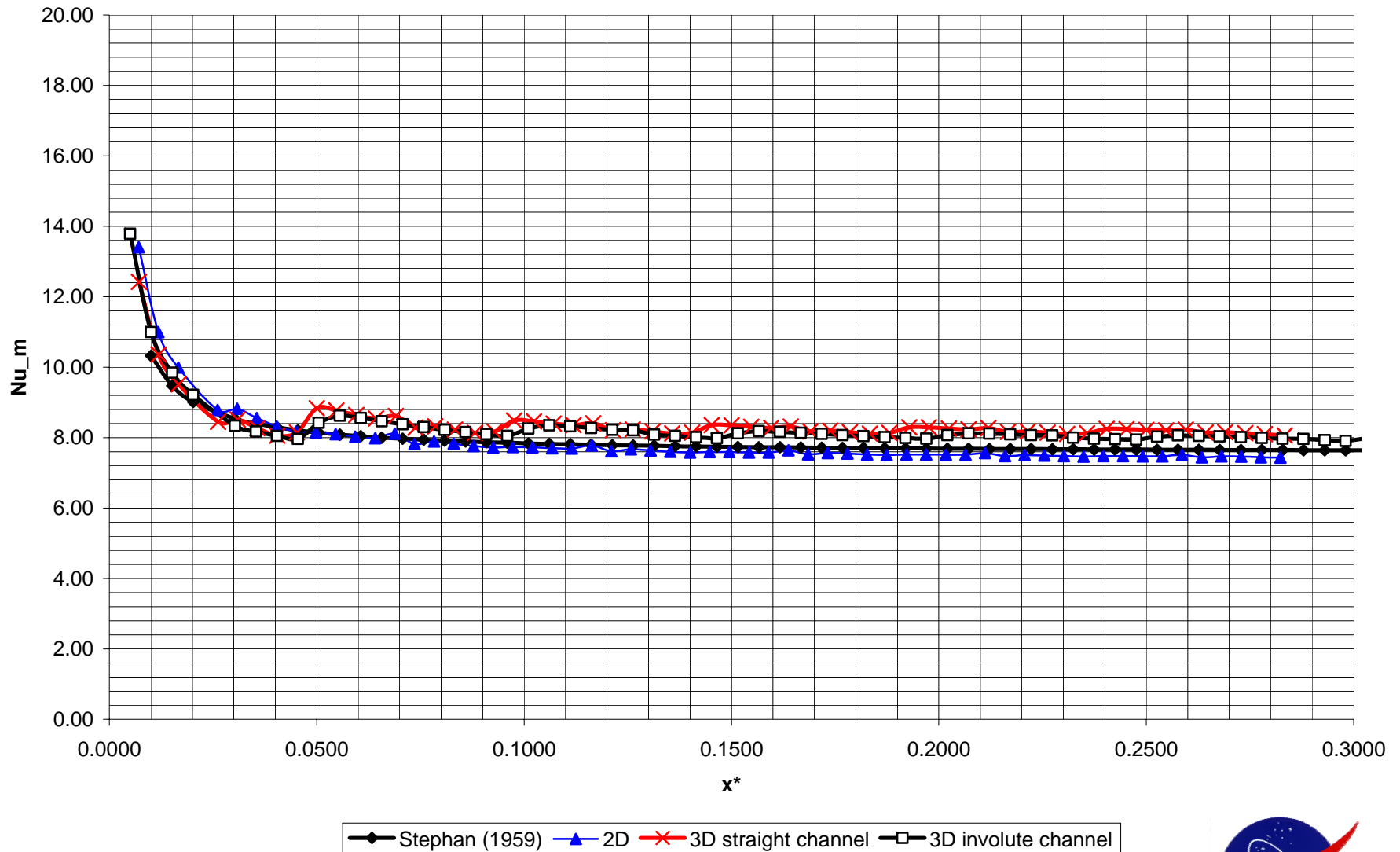

Glenn Research Center

at Lewis Field



Results of Infinia's Finite-Element Analysis of 4 Involute Foil Layers (using ANSYS shell element *shell63*—to reduce the size of the model)

Load Case	Disp. U_x (in) {plane of disk}	Disp. U_y (in) {plane of disk}	Disp. U_z (in) {axial}	Total Disp. (in)	Von Mises Stress (psi)
Case 1 (axial force)	0.734e-6	0.736e-6	0.646e-6	0.804e-6	1732
Case 2 (rad'l force)	0.111e-3	0.148e-3	0.289e-5	0.148e-3	40624
Case 3 (rad'l force)	0.462e-4	0.304e-4	0.735e-6	0.462e-4	6374

- Case 1 (44 N or 10 lb axial force) showed that the involute-foil regenerator has high axial stiffness
- For Case 2 (4.4 N or 1 lb radial-side force acting on 0.047% of the top layer outside annular ring)—the Von Mises stress was beyond the material yielding strength and permanent deformation could occur
- Case 3 (same 4.4 N force acting on 10% of the same area)—did not exceed material yielding strength
- Conclusion: Stress level is sensitive to radial side disturbance and special precautions must be taken during installation to prevent damage

Glenn Research Center

at Lewis Field

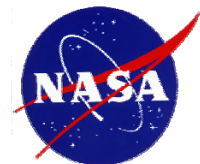

Concluding Remarks

- **Prototype nickel involute-foil regenerator tested in the NASA/Sunpower oscillating-flow test rig – Figure-of-merit ~ 2 X that of 90% porosity random fiber for Reynolds numbers in the 50-100 range – Sage has projected engine performance improvements of 6-9% to result from optimizing an engine for use of involute-foil regenerator (relative to random fiber engine)**
- **Involute-foil also expected to improve regenerator reliability & manufacturability relative to random fiber and wire screen**
- **Under the ongoing Phase III effort—an involute-foil regenerator is being fabricated (complete by June 07) for testing in a Sunpower FTB convertor. Testing/analysis may take 4-6 months.**
- **In the future, need to develop microfabrication process for:**
 - **a robust (non-nickel) material for 650 C operation**
 - **material for 850 C (Sunpower ASC) operation**
 - **material for ~1200 C for a future Venus mission**

