

JWST NIRSpec CRYOGENIC LIGHT SHIELD MECHANISM

Rajeev Sharma ⁽¹⁾

⁽¹⁾ NASA Goddard Space Flight Center, Greenbelt, Maryland, U.S.A
Rajeev.K.Sharma@nasa.gov

ABSTRACT

The focal plane detectors for the Near-Infrared Spectrometer (NIRSpec) instrument on the James Webb Space Telescope (JWST) require a light tight cover for calibration as well as an open field-of-view during ground performance testing within a cryogenic dewar. In order to achieve the light attenuation requirements when closed as well as provide a open field of view for the detectors within the cryogenic dewar, a light shield mechanism was designed. This paper discusses the details of the light shield mechanism design, development, and test results.

1. BACKGROUND

A light tight cover mechanism design and development is discussed for ground testing the Near Infrared Spectrometer Instrument's focal plane detectors on the James Webb Space Telescope. The NIRSpec focal plane detectors require a light tight cover for calibration along with an open field-of-view during ground performance testing within a cryogenic dewar. These tests include exposing the detectors to infrared light for calibration in "darkness" while under vacuum at approximately 20 degrees Kelvin (-253°C). The darkness requirement is to maintain light levels less than 0.001 electrons/sec/pixel at the detectors. In order to provide this low light level during calibration and also allow the detectors to be exposed to the required light sources when needed, the light shield mechanism was developed.

2. REQUIREMENTS

The light shield mechanism is required to attenuate light in the chamber to a level less than 0.001 electrons/sec/pixel before it reaches the detectors. Volume space allotted to the mechanism is 27.9 cm in diameter by 15.2 cm high (Ø11 in x 6 in). The shield must be able to open or close within about 60 seconds, operate in a vacuum (10^{-6} Torr) at 20 Kelvin, and in any gravitational orientation. The lifetime requirement for the shield is a few thousand cycles where one cycle is open and close.

When open, the shield door is to remain outside the 76 degree cone angle of the detector field of view. The

light shield door range of rotation is about 124 degrees from open to close.

3. SHUTTER DESIGN

A labyrinth light path is created, Figure 1, by the aligning of teeth-like protrusions on the shutter door with teeth cut outs into the plate covering the detector housing, hereafter referred to as the dewar bulkhead. The door and dewar bulkhead protrusions are separated by a gap of 0.64 mm (0.025 in) to prevent any contact debris from being created during the opening and closing operation of the door. This gap allows light entrance to the path, however, the labyrinth design combined with the proper material selection and treatment forces any light entering to bounce many times off the path's walls and thus be absorbed to levels below the requirement. Aluminum 6061, which is bead blasted and black anodized, makes up both the door and dewar bulkhead.

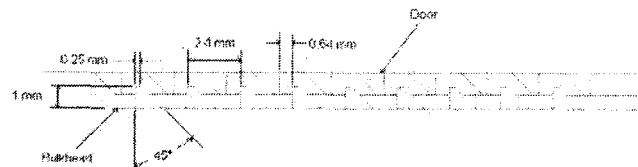

Figure 1. Light Shield Door Cross Section View.

Fabrication of parts was completed on the Micron 600U 5-axis high-speed milling machine as shown in Figure 2. The small sizes and angles of the light path protrusions make it necessary to use this machine. An additional advantage of the high speed machine is the extremely low amount of stress that is added to the part by the machining as opposed to the level normally added by typical machines. Stress is a concern due to the fact that cryogenic temperatures can cause the part's stress to increase and warp the movable door. Therefore, as well as using the high speed machine, Aluminum 6061-T651 is used to minimize stress. Aluminum 6061-T651 is heat treated to stress relieve the material.

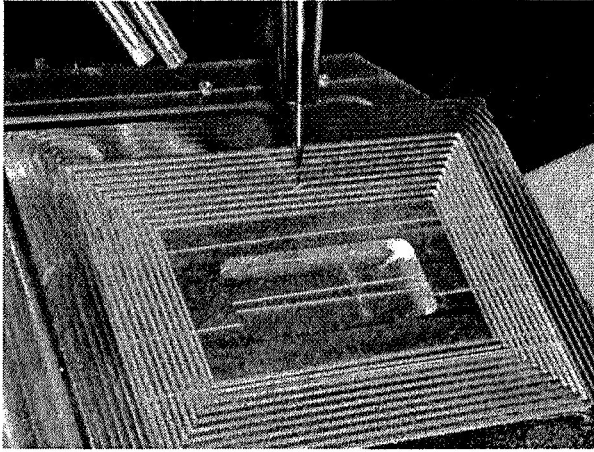

Figure 2. Shutter Door manufacturing process.

After rough-cut fabrication, the door is taken and soaked in liquid nitrogen to determine if part warping at cryogenic temperatures is an issue. Key measurements taken before and after this process are compared and it is found that the door's critical dimensions do not permanently move any significant amount. Therefore, it is determined that the cryogenic environment will not warp the door and affect its operations. Next, the dewar bulkhead plate is fabricated. Aluminum 6061- T651 is again used to minimize stress. Figure 3 shows the exploded isometric view of the mechanism.

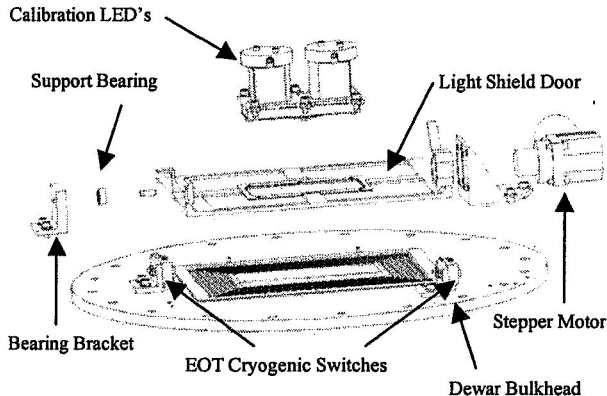

Figure 3. Light Shield Mechanism Isometric View.

4. MOTOR SELECTION

One cryogenic compatible stepper motor is used to drive the light shield door mechanism. The motor was procured from CDA Intercorp with a right angle gear head, a planetary gear train, dry film Molybdenum Disulfide (MoS_2) coated parts, a motor shaft mounted resolver for position feedback, and a keyed motor shaft interface to the door. Motor design parameters are discussed below.

4.1 Torque

Analysis indicates the light shield mechanism requires, with margin, a maximum driving torque of $0.19 \text{ N}\cdot\text{m}$ ($1.67 \text{ in}\cdot\text{lb}$) in the worst case gravity orientation. In this orientation, the door is required to be held open or closed against gravity by the motor detent alone as power must be disabled during detector tests. This motor detent torque with margin turns out to be the driving design parameter and calculates to $0.1 \text{ N}\cdot\text{m}$ ($0.88 \text{ in}\cdot\text{lb}$). A healthy factor of safety of 6 is used to bring the motor output detent torque to a $0.6 \text{ N}\cdot\text{m}$ ($5.3 \text{ in}\cdot\text{lb}$) value. The procured motor provides a measured detent torque of $0.75 \text{ N}\cdot\text{m}$ ($6.67 \text{ in}\cdot\text{lb}$).

4.2 Gearing

A right angle gear-head is essential for this mechanism design as the volume space available to mount the motor and mechanism to the dewar bulkhead is limited. The total motor gear ratio is 187:1 implying one motor step equals the door motion of 0.16 degrees. This small step size is required so that if during door motion the motor bounces back or misses a step near the fully closed position, the gap left "open" does not allow a significant amount of light to enter the light path. Analysis confirms the gap is not large enough to degrade the light shield capability of the mechanism.

4.3 Cryogenic Lubrication

Dry lubrication on the motor components is required for proper cryogenic temperature operation. A sputtered Molybdenum Disulfide (MoS_2) coating was used on the motor gears, bearings, and moving parts. MoS_2 was chosen for this mechanism based on the ability to provide any thickness needed and also its heritage on numerous previous flight programs such as COBE, Cassini, SIRTf, and others. Drawbacks in using many dry film lubricants, including MoS_2 are that the coating should be operated in a dry oxygen and water vapor free environment. Operation should not occur at humidity levels above about 40% due to the reactivity of the coating with Oxygen and water vapor.

The MoS_2 dry film lubricant sputtering process was provided by Hohman Plating Inc. In a vacuum, at 149°C (300°F), an electron emitter breaks up the lubricant material into atomic size particles which bombard the parts. The coating particles adhere to the parts' surfaces and build up thickness over time. Coatings can be co-sputtered with different elements to improve crystalline structures and lower the friction coefficient. The majority of coatings are co-sputtered with Nickel giving a 0.02 friction coefficient. More advanced co-sputter options are Antimony O_3 ($\mu =$

6. OVER TRAVEL ANALYSIS

As the light shield reaches its end of travel in either the open or close direction, it comes into contact with an end-of-travel switch. This switch then cuts off power to the motor and the door stops its motion. In the close direction there is a hard stop that does not allow the door to over travel. Travel in the open direction, however, does not have a hard stop. Therefore, stress analysis is performed on the tab that comes into contact with the switch to determine the maximum amount of force that can be handled. These calculations determine that the load felt on the tab is 20 times smaller than the yield load of the door material, including margin. Therefore, at the slow speed that the motor rotates, the tab contacting the switch will not yield if the motor attempts to continue to rotate, and the shield door will not over travel.

7. CRYOGENIC TESTING AND OPERATIONS

Before delivery to the project, the light shield mechanism is tested in a dewar at 20K in the operational configuration. The dewar bulkhead is attached to an interface plate to mate the mechanism to the chamber. Once assembly is complete, the chamber is closed and then rotated 180° to orient the mechanism to its operational configuration. This places the mechanism so that gravity is acting to open the door from its closed position.

Special thanks goes to Mike Dube and Mark McLendon of the NASA-GSFC Materials Group for their analysis and insight in evaluating the coatings of the actuator parts.