

# A Retro-Fit Control Architecture to Maintain Engine Performance With Usage

*Jonathan S. Litt*

*U.S. Army Research Laboratory, Glenn Research Center, Cleveland, Ohio*

*T. Shane Sowers*

*Analex Corporation, Cleveland, Ohio*

*Sanjay Garg*

*Glenn Research Center, Cleveland, Ohio*

## NASA STI Program . . . in Profile

Since its founding, NASA has been dedicated to the advancement of aeronautics and space science. The NASA Scientific and Technical Information (STI) program plays a key part in helping NASA maintain this important role.

The NASA STI Program operates under the auspices of the Agency Chief Information Officer. It collects, organizes, provides for archiving, and disseminates NASA's STI. The NASA STI program provides access to the NASA Aeronautics and Space Database and its public interface, the NASA Technical Reports Server, thus providing one of the largest collections of aeronautical and space science STI in the world. Results are published in both non-NASA channels and by NASA in the NASA STI Report Series, which includes the following report types:

- **TECHNICAL PUBLICATION.** Reports of completed research or a major significant phase of research that present the results of NASA programs and include extensive data or theoretical analysis. Includes compilations of significant scientific and technical data and information deemed to be of continuing reference value. NASA counterpart of peer-reviewed formal professional papers but has less stringent limitations on manuscript length and extent of graphic presentations.
- **TECHNICAL MEMORANDUM.** Scientific and technical findings that are preliminary or of specialized interest, e.g., quick release reports, working papers, and bibliographies that contain minimal annotation. Does not contain extensive analysis.
- **CONTRACTOR REPORT.** Scientific and technical findings by NASA-sponsored contractors and grantees.

- **CONFERENCE PUBLICATION.** Collected papers from scientific and technical conferences, symposia, seminars, or other meetings sponsored or cosponsored by NASA.
- **SPECIAL PUBLICATION.** Scientific, technical, or historical information from NASA programs, projects, and missions, often concerned with subjects having substantial public interest.
- **TECHNICAL TRANSLATION.** English-language translations of foreign scientific and technical material pertinent to NASA's mission.

Specialized services also include creating custom thesauri, building customized databases, organizing and publishing research results.

For more information about the NASA STI program, see the following:

- Access the NASA STI program home page at <http://www.sti.nasa.gov>
- E-mail your question via the Internet to [help@sti.nasa.gov](mailto:help@sti.nasa.gov)
- Fax your question to the NASA STI Help Desk at 301-621-0134
- Telephone the NASA STI Help Desk at 301-621-0390
- Write to:  
NASA Center for AeroSpace Information (CASI)  
7115 Standard Drive  
Hanover, MD 21076-1320

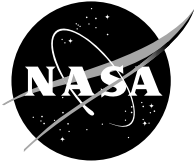

# A Retro-Fit Control Architecture to Maintain Engine Performance With Usage

*Jonathan S. Litt*

*U.S. Army Research Laboratory, Glenn Research Center, Cleveland, Ohio*

*T. Shane Sowers*

*Analex Corporation, Cleveland, Ohio*

*Sanjay Garg*

*Glenn Research Center, Cleveland, Ohio*

Prepared for the  
18th ISABE Conference (ISABE 2007)  
sponsored by the International Society for Airbreathing Engines  
Beijing, China, September 2–7, 2007

National Aeronautics and  
Space Administration

Glenn Research Center  
Cleveland, Ohio 44135

## Acknowledgments

The authors wish to thank the NASA Aviation Safety Program Integrated Resilient Aircraft Control Project for supporting this work. The authors also wish to thank Takahisa Kobayashi for his continued invaluable technical assistance and advice.

This report is a formal draft or working paper, intended to solicit comments and ideas from a technical peer group.

This report contains preliminary findings, subject to revision as analysis proceeds.

This report is a preprint of a paper intended for presentation at a conference. Because changes may be made before formal publication, this preprint is made available with the understanding that it will not be cited or reproduced without the permission of the author.

*Level of Review:* This material has been technically reviewed by technical management.

Available from

NASA Center for Aerospace Information  
7115 Standard Drive  
Hanover, MD 21076-1320

National Technical Information Service  
5285 Port Royal Road  
Springfield, VA 22161

Available electronically at <http://gltrs.grc.nasa.gov>

# A Retro-Fit Control Architecture to Maintain Engine Performance with Usage

Jonathan S. Litt  
U.S. Army Research Laboratory  
Glenn Research Center  
Cleveland, Ohio 44135

T. Shane Sowers  
Analex Corporation  
Cleveland, Ohio 44135

Sanjay Garg  
National Aeronautics and Space Administration  
Glenn Research Center  
Cleveland, Ohio 44135

## Abstract

An outer loop retrofit engine control architecture is presented which modifies fan speed command to obtain a desired thrust based on throttle position. This maintains the throttle-to-thrust relationship in the presence of engine degradation, which has the effect of changing the engine's thrust output for a given fan speed. Such an approach can minimize thrust asymmetry in multi-engine aircraft, and reduce pilot workload. The outer loop control is demonstrated under various levels of engine deterioration using a standard deterioration profile as well as an atypical profile. It is evaluated across various transients covering a wide operating range. The modified fan speed command still utilizes the standard engine control logic so all original life and operability limits remain in place. In all cases it is shown that with the outer loop thrust control in place, the deteriorated engine is able to match the thrust performance of a new engine up to the limits the controller will allow.

## Nomenclature

EGT	Exhaust Gas Temperature
FADEC	Full Authority Digital Engine Control
PI	Proportional-Integral
PLA	Power Lever Angle

## Introduction

In a workshop sponsored by NASA to identify technology development needs for reducing pilot workload and increasing autonomy with respect to operation of aircraft engines, pilots identified several areas that should be addressed. These included having to individually adjust throttles to match thrust in a multi-engine airplane, and lack of information to the pilot about vehicle status while under autopilot. Thrust asymmetry is often handled by the autopilot through manipulation of the

flight control surfaces, but this presents two problems. First, the excess thrust is counteracted by the control surfaces, thereby increasing drag and thus wasting fuel (ref. 1). Second, the autopilot itself has been behind some loss of control type accidents by masking aerodynamic cues until a situation develops from which airplane recovery is difficult (ref. 2). Both of these reasons support a propulsion solution. Since a hotter running engine leads to a thrust increase as the engine deteriorates over time (ref. 3), rather than increasing drag, decreasing fuel flow is a viable option for automatic compensation of thrust asymmetry caused by deterioration. This leads to more efficient thrust balancing, reduces pilot workload which by itself can improve safety, and eliminates a potential source of confusion to the pilot by correcting a propulsion system irregularity through propulsion control rather than the autopilot.

This could all be achieved through direct control of engine thrust, if thrust were measurable in flight which it is not. However, a traditional engine control system can be retrofitted to provide an adjustment to the nominal control signal that accomplishes the same thing. The remaining sections of this paper describe such a retrofit approach, report on evaluation testing, and draw conclusions.

## Background

Since thrust is not measurable in flight, engine controllers typically regulate fan speed or engine pressure ratio, which are indicators of thrust. Additionally, the controller contains limit logic to protect the engine from overspeed and over-temperature conditions to maintain life, and acceleration and deceleration schedules to prevent stall and flame-out (ref. 4). A typical engine control architecture such as that found in a Full Authority Digital Engine Controller (FADEC) is shown in figure 1. This representative example shows how the pilot sets fan speed through Power Lever Angle (PLA) or throttle position, which is mapped into a fuel flow command to the engine. Internally this FADEC uses control logic consisting of

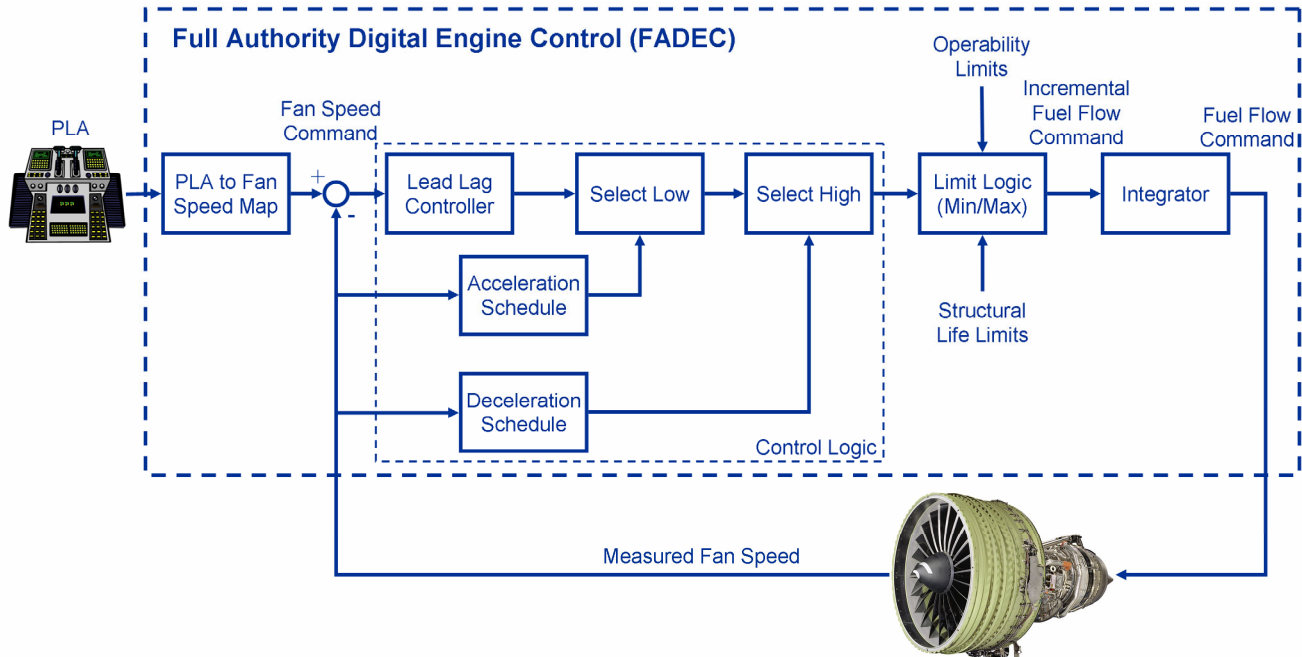

Figure 1.—Typical Full Authority Digital Engine Control (FADEC) for controlling engine fan speed.

a Lead/Lag controller and acceleration and deceleration schedules, and limit logic to set a final fuel flow value that will enable the engine to follow fan speed commands with a responsiveness that gives acceptable performance while still providing good fuel economy, long component life, and sufficient operability margins.

A typical FADEC of this type will maintain fan speed at the level corresponding to the PLA setpoint commanded by the pilot. When the relationship between fan speed and thrust is known and consistent, setting fan speed, which is a measured variable, is equivalent to setting thrust. However, engine-to-engine variation in performance and operability, typically due to manufacturing tolerances, can cause up to 0.5% thrust disparity in new engines. As engines age and deteriorate with use, these differences can grow. For a multi-engine aircraft, the difference in fan speed to thrust relationship results in variations in PLA to thrust response for different engines.

Continued engine degradation with use is caused by such phenomena as rubs, erosion, oxidation, etc. which result in changes in the component efficiencies, flow capacities, seal leakages, etc., which collectively describe the engine's health. These variables are known as the engine health parameters. Because of the variety of causes of degradation combined with the fact that they do not impact all components the same way, engine health parameter values can vary widely from engine to engine as wear occurs. Thus, when individual health parameters from a fleet of engines are analyzed, it may appear that they degrade randomly, but for any individual engine they generally tend to have a trajectory consisting of a rapid break-in period followed by a period of fairly steady shift (ref. 5). Thus, deterioration patterns tend to be similar across a fleet of engines although the rapidity with which it occurs varies. Abnormal wear can also occur, depending on the operating environment or events such as foreign object damage (FOD).

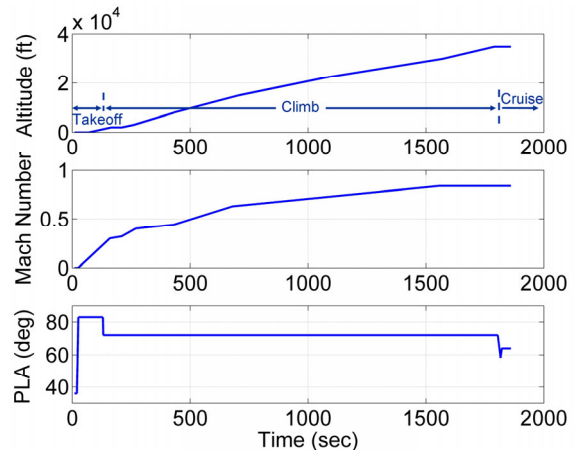

Figure 2.—Typical take-off/climb/cruise trajectory.

For the purposes of this work, it is assumed that the health parameters deteriorate along an arbitrary profile, meaning that they start out together at their initial values and shift together through their fully deteriorated level. Deterioration level is indicated by the percent of life (flight cycles) that has passed. The health parameter values change quickly initially and more slowly at the end. Shifts in the engine health parameters show up as shifts in measured variables such as exhaust gas temperature (EGT). Typically peak EGT at takeoff increases as a function of flight cycles (takeoffs and landings) until it reaches a limit, at which point the engine must be removed from service for maintenance; thus EGT is used as an indicator of engine health.

A typical takeoff/climb/cruise trajectory is shown in figure 2. Figure 3 shows thrust of an engine using FADEC fan speed control over this trajectory with a variety of deterioration levels; thrust is normalized by its nominal level at cruise. Here the

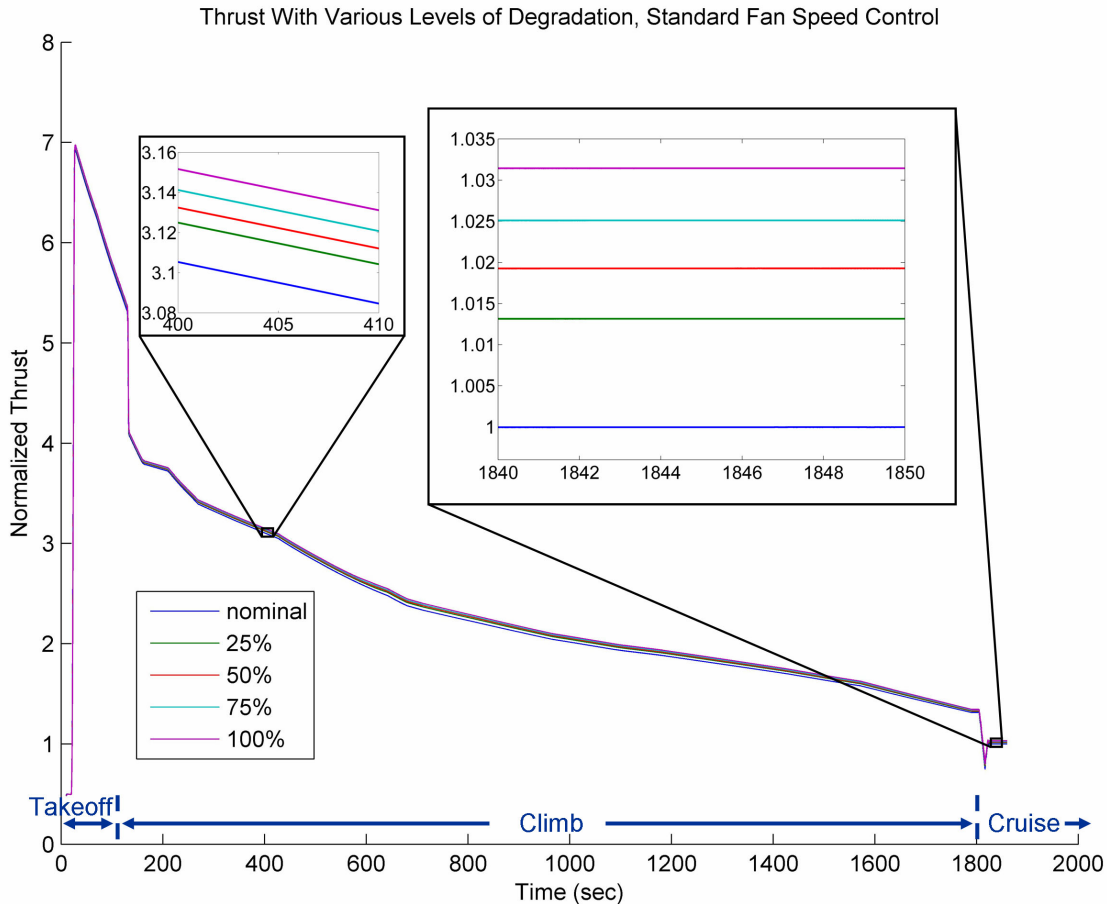

Figure 3.—Normalized thrust through takeoff/climb/cruise transient scaled by nominal level at cruise, with traditional fan speed control. The insets show the shift in thrust level with engine deterioration.

throttle movements and thus the fan speed trajectory are the same for all cases, while thrust increases from run to run. This clearly points out the impact of deterioration on thrust response. One inset shows the shift at cruise, where the fully deteriorated engine produces over 3% more thrust than a new engine (the magnitude of the shift is similar across the transient but is smaller percentage wise), which has the potential to cause asymmetric thrust.

One approach to addressing the issue of providing consistent throttle to thrust response is to change the overall control architecture to a model-based control (ref. 6). A model-based system would enable direct control of a thrust estimate; however, this approach is expected to take a long time to reach a high enough level of technical maturity to be able to meet the stringent certification requirements for safe operation of aircraft engines. The FADEC used for implementing typical engine control has both throughput and processing limits which make a full model-based control implementation very challenging. Additionally, the FADEC already contains limit logic that is designed to guarantee safe operation of the engine over a wide operating envelope and under varying atmospheric conditions, and to enable an economically viable on-wing life. For these reasons, it is imperative to find a solution to the consistent throttle to thrust requirement which can be

implemented within existing FADEC capabilities and will require minimal changes in the existing control implementations for operational safety.

## Retrofit Architecture

An Engine Performance Deterioration Mitigating Control (EPDMC) retrofit architecture is proposed here that can alleviate the problem of asymmetric thrust due to uneven engine deterioration, potentially reducing workload and saving fuel. It is based on the results of previous studies but with a significant improvement that allows the full utilization of the FADEC's control capabilities. The architecture is depicted in figure 4. It is built on the existing FADEC control logic but with an outer loop thrust control that gives a consistent throttle to thrust response. Here the inner loop control is simply the existing FADEC logic with fan speed feedback. This retains all of the certified control and limit logic that protects the engine. Three blocks have been added to facilitate the adjustment of the fan speed command to effectively control thrust. They are: the Thrust Model which determines what the thrust from a new engine would be for the given PLA setting and ambient conditions; the Thrust Estimator which estimates the

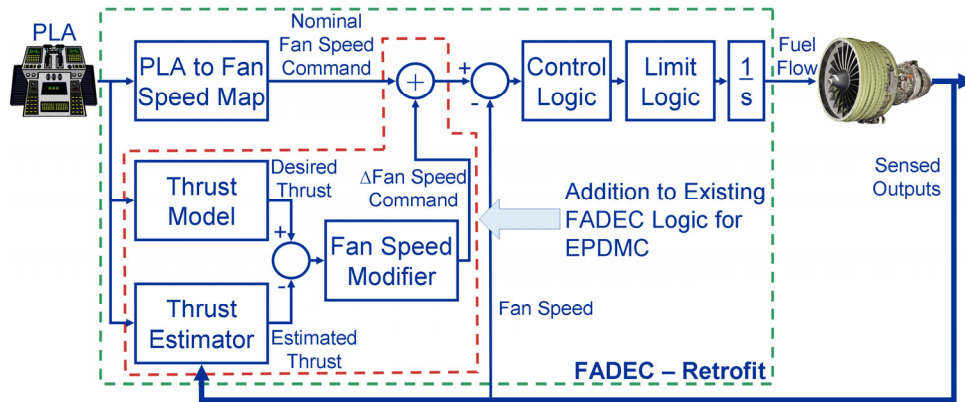

Figure 4.—FADEC retrofit with Engine Performance Deterioration Mitigating Control (EPDMC).

thrust the engine is actually producing from measured outputs; and the Fan Speed Modifier which calculates the fan speed adjustment required for the engine's thrust to match the Thrust Model.

## EPDMC Application

In the research described here, EPDMC is applied to a large commercial turbofan engine on which fan speed is controlled with a standard FADEC-type controller. The implementation of EPDMC consists of adding the three blocks (Thrust Model, Thrust Estimator, and Fan Speed Modifier from fig. 4) that together create the  $\Delta$  fan speed command that produces the adjustment of thrust. Referring to figure 4, the Thrust Model is a table-lookup nominal engine model of thrust values at various grid points within the flight envelope. Thrust values between points in the table are interpolated. These thrust values provide a thrust trajectory for the outer loop controller to track as the engine moves through the flight envelope. The Thrust Estimator employs a Kalman filter to estimate the engine health parameters, and these values are used to determine the thrust deviation from nominal due to degradation. The Kalman filter is designed using the available engine sensors for input. A problem arises when the engine has too few sensors to properly estimate all modeled health parameters (which is typically the case), so some approximation must be performed to compute thrust deviation. Here the thrust estimator uses a reduced order model of the degraded engine to obtain an optimal least squares estimate (ref. 7). The reduction is performed in such a way that the estimated parameters no longer represent the actual engine health parameters, but still capture their effect on the measured and modeled variables such as thrust. It must be reiterated that while this is a model-based estimation approach, the controller itself preserves the limit logic and schedules, which is why the retrofit approach is so attractive; all of the design, validation, and certification effort that went into the control scheme is retained. Finally, the Fan Speed Modifier block of figure 4 is implemented as a Proportional-Integral (PI) controller, gain-

scheduled as a function of PLA so that it provides a fairly consistent closed loop response at all power settings. It has Integrator Windup Protection so it will stop integrating the thrust error signal if the limit logic is active. The outer loop thrust control is slower-acting than the inner loop fan speed control, so the objective of the outer loop controller is to eliminate steady state thrust error. Under normal operation of a commercial turbofan engine, the nominal thrust changes rather slowly and smoothly, so the EPDMC implementation should be able to track thrust well except during the fastest parts of the transient.

This is the first full implementation of this version of EPDMC. Previous research studies demonstrated  $\Delta$  fan speed command using a point design inner loop PI controller with no additional control or limit logic (ref. 8) and  $\Delta$  PLA command with a FADEC-like controller (ref. 9). This new approach demonstrates  $\Delta$  fan speed control using a FADEC-like controller including limit logic. The difference between this new approach and that in reference 9 is that here the fan speed request is adjusted, constrained only by the engine limit logic, thereby avoiding the throttle movement limits encountered in the previous study. The modification must be made within the FADEC, but since the approach uses existing limit logic, the change is minimal. The PLA setting enters the FADEC and is converted to a fan speed command. The adjustment due to deterioration is added on to this value, as opposed to the previous approach where the throttle command was augmented and this total value was converted to a fan speed command within the range of PLA movement.

For evaluation of this EPDMC implementation, the first step is to demonstrate that the error in the thrust estimate is small compared to the thrust deviation due to deterioration using FADEC fan speed control. This implies that closing the loop on the thrust estimate will result in an improvement in thrust tracking over fan speed control alone for deteriorated engines. Figure 5 shows the normalized deviation in thrust (actual thrust shown in fig. 3 minus a thrust reference from the simplified nominal engine model, divided by the nominal level at cruise) across the takeoff/climb/cruise transient shown in



figure 2 for various levels of deterioration. It can be clearly seen that there is thrust deviation from nominal that increases with deterioration. Also shown in figure 5 is the normalized error in thrust estimate for the same levels of deterioration. Here the error is significantly smaller than the thrust deviation, implying that closing the loop on thrust estimate will produce only a small error in thrust tracking up to the limit of the controller.

The takeoff/climb/cruise thrust transient shown in figure 3 is shown again in figure 6 with the same levels of deterioration, i.e., a typical degradation profile. Now, however, EPDMC is in use, and the insets in figure 6 show how well the thrust is maintained. Where with typical fan speed control the thrust deviation was over 3% at cruise (fig. 3), here this deviation is significantly less than 0.5%.

Figure 7 shows the difference in fan speed between the cases with EPDMC and fan speed control. Fan speed is higher with traditional FADEC control because EPDMC reduces fan speed to bring thrust down to the nominal level. The more degraded the engine is, the more fan speed is reduced using EPDMC to maintain thrust.

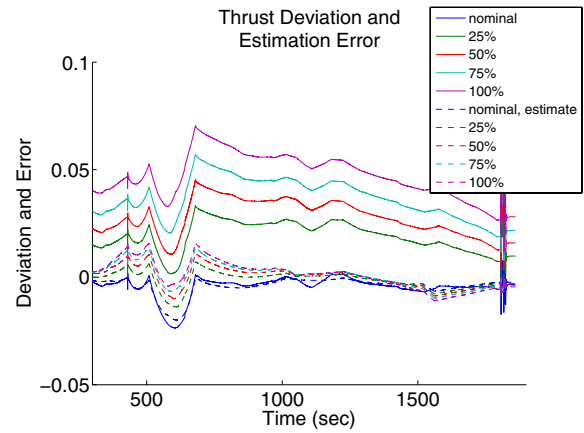

Figure 5.—Normalized thrust deviation (solid lines) and normalized thrust estimation errors (dashed lines) with degradation.

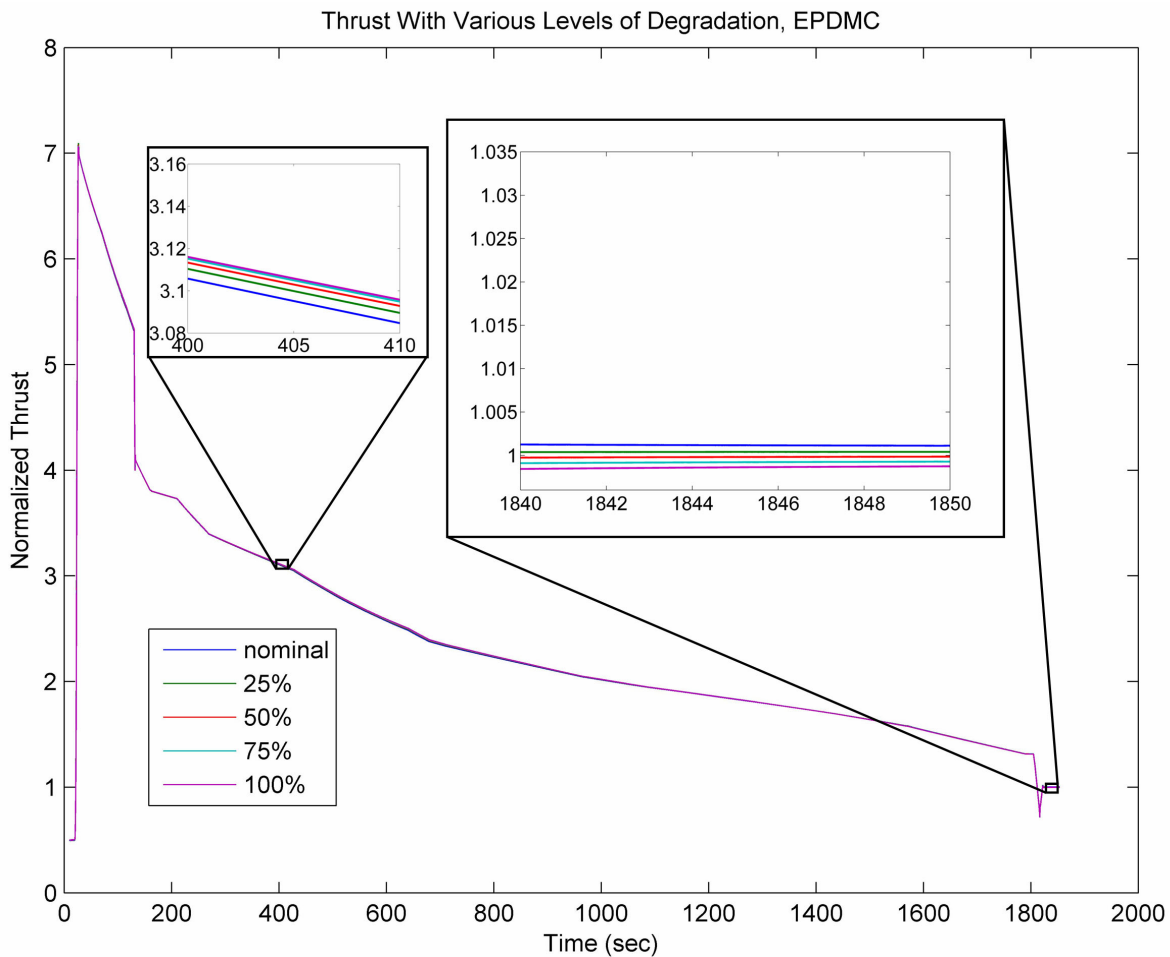

Figure 6.—Normalized thrust through takeoff/climb/cruise transient scaled by nominal level at cruise, with EPDMC retrofit. The insets show the nominal thrust level is essentially maintained regardless of engine deterioration.

An added benefit of EPDMC over traditional fan speed control is a reduction in EGT, which is shown in table 1. This is especially important during takeoff where high EGT is cause for engine removal. Since a standard deterioration profile results in higher EGT over time, cooler takeoff EGT might mean longer on-wing time for the engine. If high EGT is the sole reason for removal, an engine is 100% deteriorated when it has reached its EGT limit. For the 100% deteriorated engine used in this example, the 10 °F reduction in takeoff EGT using EPDMC could potentially result in about 5-10% more useful life, based on the rate of EGT increase with deterioration.

TABLE 1.— $\Delta$ EGT AT TAKEOFF BETWEEN ENGINE WITH TRADITIONAL FAN SPEED CONTROL AND EPDMC

Deterioration level	0%	25%	50%	75%	100%
$\Delta$ EGT	0 °F	-5 °F	-6 °F	-8 °F	-10 °F

Figure 8 shows the instantaneous reduction in fuel flow that can be achieved using EPDMC to track thrust. For instance, for the 75% deteriorated engine example, a 2-hr cruise would result in a savings of over 400 lb of fuel, or about 2.5%. Generally thrust increases with wear, but variation in operating conditions, manufacturing, and materials, and foreign object damage (FOD) events can produce atypical degradation. In particular, deterioration that affects only the cold section of the engine results in reduced thrust as the engine ages. In such cases, during a takeoff/climb/cruise transient, the EPDMC increases the fan speed unless a limit is reached. Example thrust transients are shown in figure 9, where it is clear that the EPDMC approach successfully maintains thrust and is constrained only by controller limits, which are in place for structural or operability reasons. It must be noted, however, that this type of deterioration is atypical and in most cases EPDMC will act to reduce thrust, meaning that the scenario in this example will rarely occur in a fleet.

Figure 10 shows the thrust responses to a burst and chop transient, which consists of throttle snaps from high power to idle and back from some steady condition, for a fully deteriorated engine both with fan speed control and with EPDMC. Additionally, it shows a limit flag when the control signal is limited by the FADEC logic (low=no limit, high=limited). This figure indicates that EPDMC not only tracks the thrust very well—at high power thrust is slightly oscillatory both with and without EPDMC, but the actual thrust tracks the reference with EPDMC, while it is too high otherwise—but that the controller reacts in a very similar way to the case of a new engine with traditional fan speed control. Notice how the fuel flow for the deteriorated engine with standard control is limited at high power, which is clear from the limit flag, which remains high as long as the thrust level is high. This engine’s smaller thrust bias at high power as compared to mid power is an indication that commanded fan speed cannot be met because of the fuel flow limit. This example demonstrates that EPDMC respects engine limits, and that it maintains the

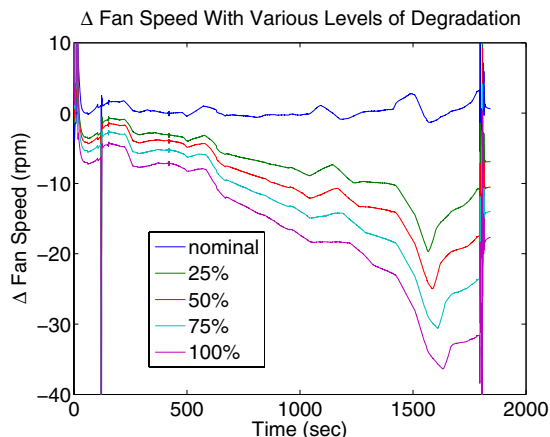

Figure 7.—Difference in fan speed transient with EPDMC and standard fan speed control, across the takeoff/climb/cruise trajectory for various levels of engine degradation along standard degradation profile.

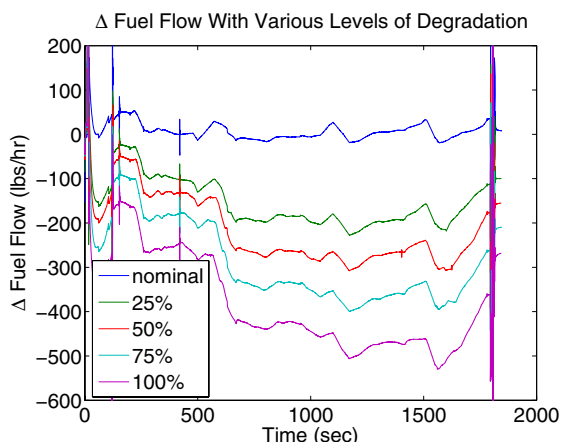

Figure 8.—Difference in fuel flow transient with EPDMC and standard fan speed control, across the takeoff/climb/cruise trajectory for various levels of engine degradation along standard degradation profile.

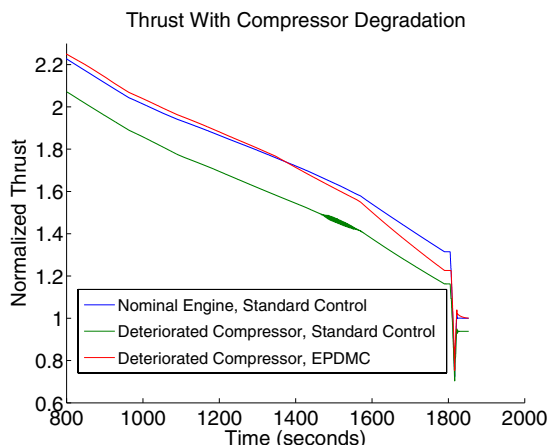

Figure 9.—Normalized thrust with atypical compressor deterioration case.

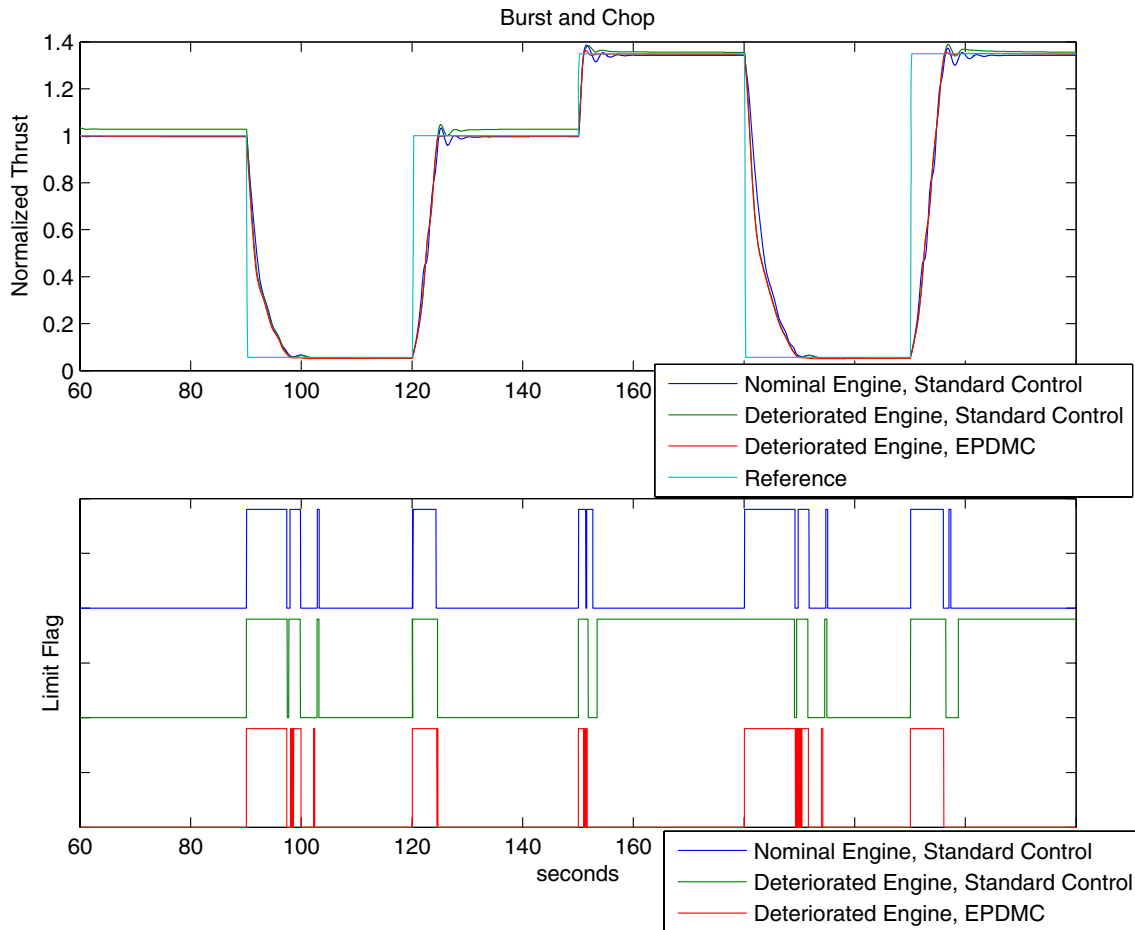

Figure 10.—Burst and chop. The limit flags show when the fuel flow is limited by the FADEC logic.

throttle-to-thrust relationship better and tracks thrust more consistently than standard fan speed control does for a fully deteriorated engine.

## Conclusions

A retrofit control approach for maintaining the engine throttle-to-thrust response has been presented and demonstrated. The Engine Performance Deterioration Mitigating Control (EPDMC) thrust control architecture was shown to perform extremely well on an engine flying a standard trajectory with a typical deterioration profile. In all cases it was able to track thrust and reduce EGT and fuel consumption. Testing using a burst and chop transient showed that the EPDMC incremental control signal was active only when the traditional control was not limited, implying that under normal conditions it does not drive the fuel flow to a limiting condition any more than a traditional fan speed controller does. The more challenging test came on a case with atypical engine deterioration that decreased thrust with deterioration. Here the EPDMC increased fuel flow until a controller limit was reached at which

point thrust deviated from the desired, but still the thrust response was significantly closer to desired than for the standard fan speed control case. Because the retrofit approach allows the FADEC limit logic to remain intact, the EPDMC is as safe and reliable as a standard engine control that maintains fan speed, but was shown to reduce fuel consumption and potentially extend on-wing life under normal deterioration scenarios. Because EPDMC is able to maintain throttle-to-thrust response characteristics as the engine ages, it is a candidate for reducing pilot workload by eliminating the need for manual throttle manipulation to reduce thrust asymmetry. For the implementation to be attempted on a real engine, additional work still needs to be carried out. One area of future research is the optimization of memory and processing to enable EPDMC to run on a FADEC. Work must also be performed on a diagnostic system for thrust asymmetry. Even though EPDMC is able to control thrust and thus minimize imbalance, if the underlying cause is not just deterioration, it might require some action that would preclude the use of EPDMC.

## References

1. Balut Ostrum, G., "Propulsion Aspects of the Thrust Asymmetry Compensation System (TAC) on the Boeing 777 Airplane," ASME paper 98-GT-457, International Gas Turbine & Aeroengine Congress & Exhibition, 43rd, Stockholm, Sweden, Jun. 2-5, 1998.
2. Sallee, G.P., Gibbons, D.M., AIA/AECMA Project Report on Propulsion System Malfunction Plus Inappropriate Crew Response (PSM+ISR), Volume 1, 1 Nov. 1998.
3. Brunell, B.J., Viassolo, D.E., and Prasanth, R., "Model Adaptation and Nonlinear Model Predictive Control of an Aircraft Engine," GT2004-53780, Proceedings of the 2004 ASME Turbo Expo, Vienna, Austria, Jun. 14-17, 2004.
4. Mattingly, J.D., Heiser, W.H., Pratt, D.T., Aircraft Engine Design, Second Edition, AIAA Education Series, AIAA, Reston, VA, 2002.
5. Sasahara, O., "JT9D Engine/Module Performance Deterioration Results From Back to Back Testing," ISABE 85-7061, Seventh International Symposium on Air Breathing Engines, Beijing, PRC, Sep. 2-6, 1985.
6. Litt, J.S., et al., "A Survey of Intelligent Control and Health Management Technologies for Aircraft Propulsion Systems," *Journal of Aerospace Computing, Information, and Communication* [online journal], vol. 1, no. 12, Dec. 2004, pp. 543-563, URL: [www.aiaa.org/jaicic/](http://www.aiaa.org/jaicic/), [cited 2 Sep. 2005].
7. Litt, J.S., "An Optimal Orthogonal Decomposition Method for Kalman Filter-Based Turbofan Engine Thrust Estimation," GT2005-68808, Proceedings of the 2005 ASME Turbo Expo, Reno-Tahoe, NV, Jun. 6-9, 2005.
8. Litt, Jonathan S., Turso, James A., Shah, Neerav, Sowers, T. Shane, and Owen, A. Karl, "A Demonstration of a Retrofit Architecture for Intelligent Control and Diagnostics of a Turbofan Engine," NASA/TM-2005-214019, ARL-TR-3667, AIAA-2005-6905, Dec. 2005.
9. Litt, Jonathan S., Sowers, T. Shane, "Evaluation of an Outer Loop Retrofit Architecture for Intelligent Turbofan Engine Thrust Control," NASA/TM-2006-214460, ARL-TR-3880, AIAA-2006-5103, Oct. 2006.

**REPORT DOCUMENTATION PAGE**

*Form Approved*  
OMB No. 0704-0188

The public reporting burden for this collection of information is estimated to average 1 hour per response, including the time for reviewing instructions, searching existing data sources, gathering and maintaining the data needed, and completing and reviewing the collection of information. Send comments regarding this burden estimate or any other aspect of this collection of information, including suggestions for reducing this burden, to Department of Defense, Washington Headquarters Services, Directorate for Information Operations and Reports (0704-0188), 1215 Jefferson Davis Highway, Suite 1204, Arlington, VA 22202-4302. Respondents should be aware that notwithstanding any other provision of law, no person shall be subject to any penalty for failing to comply with a collection of information if it does not display a currently valid OMB control number.

PLEASE DO NOT RETURN YOUR FORM TO THE ABOVE ADDRESS.

<b>1. REPORT DATE (DD-MM-YYYY)</b> 01-09-2007		<b>2. REPORT TYPE</b> Technical Memorandum		<b>3. DATES COVERED (From - To)</b>	
<b>4. TITLE AND SUBTITLE</b> A Retro-Fit Control Architecture to Maintain Engine Performance With Usage				<b>5a. CONTRACT NUMBER</b>	
				<b>5b. GRANT NUMBER</b>	
				<b>5c. PROGRAM ELEMENT NUMBER</b>	
<b>6. AUTHOR(S)</b> Litt, Jonathan, S.; Sowers, T., Shane; Garg, Sanjay				<b>5d. PROJECT NUMBER</b>	
				<b>5e. TASK NUMBER</b>	
				<b>5f. WORK UNIT NUMBER</b> WBS 457280.02.07.03.04	
<b>7. PERFORMING ORGANIZATION NAME(S) AND ADDRESS(ES)</b> National Aeronautics and Space Administration John H. Glenn Research Center at Lewis Field Cleveland, Ohio 44135-3191				<b>8. PERFORMING ORGANIZATION REPORT NUMBER</b> E-16135	
<b>9. SPONSORING/MONITORING AGENCY NAME(S) AND ADDRESS(ES)</b> National Aeronautics and Space Administration Washington, DC 20546-0001 and U.S. Army Research Laboratory Adelphi, Maryland 20783-1145				<b>10. SPONSORING/MONITORS ACRONYM(S)</b> NASA, ARL	
				<b>11. SPONSORING/MONITORING REPORT NUMBER</b> NASA/TM-2007-214977; ARL-TR-4130	
<b>12. DISTRIBUTION/AVAILABILITY STATEMENT</b> Unclassified-Unlimited Subject Category: 07 Available electronically at <a href="http://gltrs.grc.nasa.gov">http://gltrs.grc.nasa.gov</a> This publication is available from the NASA Center for AeroSpace Information, 301-621-0390					
<b>13. SUPPLEMENTARY NOTES</b>					
<b>14. ABSTRACT</b> An outer loop retrofit engine control architecture is presented which modifies fan speed command to obtain a desired thrust based on throttle position. This maintains the throttle-to-thrust relationship in the presence of engine degradation, which has the effect of changing the engine's thrust output for a given fan speed. Such an approach can minimize thrust asymmetry in multi-engine aircraft, and reduce pilot workload. The outer loop control is demonstrated under various levels of engine deterioration using a standard deterioration profile as well as an atypical profile. It is evaluated across various transients covering a wide operating range. The modified fan speed command still utilizes the standard engine control logic so all original life and operability limits remain in place. In all cases it is shown that with the outer loop thrust control in place, the deteriorated engine is able to match the thrust performance of a new engine up to the limits the controller will allow.					
<b>15. SUBJECT TERMS</b> Propulsion; Engine control; Control systems design; Adaptive control					
<b>16. SECURITY CLASSIFICATION OF:</b>			<b>17. LIMITATION OF ABSTRACT</b>	<b>18. NUMBER OF PAGES</b>	<b>19a. NAME OF RESPONSIBLE PERSON</b>
<b>a. REPORT</b>	<b>b. ABSTRACT</b>	<b>c. THIS PAGE</b>			STI Help Desk (email:help@sti.nasa.gov)
U	U	U	UU	14	<b>19b. TELEPHONE NUMBER (include area code)</b> 301-621-0390



