

NASA/TM—2007-215007



Feedback Control Systems Loop Shaping Design With Practical Considerations

George Kopasakis
Glenn Research Center, Cleveland, Ohio

September 2007

NASA STI Program . . . in Profile

Since its founding, NASA has been dedicated to the advancement of aeronautics and space science. The NASA Scientific and Technical Information (STI) program plays a key part in helping NASA maintain this important role.

The NASA STI Program operates under the auspices of the Agency Chief Information Officer. It collects, organizes, provides for archiving, and disseminates NASA's STI. The NASA STI program provides access to the NASA Aeronautics and Space Database and its public interface, the NASA Technical Reports Server, thus providing one of the largest collections of aeronautical and space science STI in the world. Results are published in both non-NASA channels and by NASA in the NASA STI Report Series, which includes the following report types:

- **TECHNICAL PUBLICATION.** Reports of completed research or a major significant phase of research that present the results of NASA programs and include extensive data or theoretical analysis. Includes compilations of significant scientific and technical data and information deemed to be of continuing reference value. NASA counterpart of peer-reviewed formal professional papers but has less stringent limitations on manuscript length and extent of graphic presentations.
- **TECHNICAL MEMORANDUM.** Scientific and technical findings that are preliminary or of specialized interest, e.g., quick release reports, working papers, and bibliographies that contain minimal annotation. Does not contain extensive analysis.
- **CONTRACTOR REPORT.** Scientific and technical findings by NASA-sponsored contractors and grantees.

- **CONFERENCE PUBLICATION.** Collected papers from scientific and technical conferences, symposia, seminars, or other meetings sponsored or cosponsored by NASA.
- **SPECIAL PUBLICATION.** Scientific, technical, or historical information from NASA programs, projects, and missions, often concerned with subjects having substantial public interest.
- **TECHNICAL TRANSLATION.** English-language translations of foreign scientific and technical material pertinent to NASA's mission.

Specialized services also include creating custom thesauri, building customized databases, organizing and publishing research results.

For more information about the NASA STI program, see the following:

- Access the NASA STI program home page at <http://www.sti.nasa.gov>
- E-mail your question via the Internet to help@sti.nasa.gov
- Fax your question to the NASA STI Help Desk at 301-621-0134
- Telephone the NASA STI Help Desk at 301-621-0390
- Write to:
NASA Center for AeroSpace Information (CASI)
7115 Standard Drive
Hanover, MD 21076-1320

NASA/TM—2007-215007

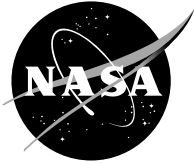

Feedback Control Systems Loop Shaping Design With Practical Considerations

George Kopasakis
Glenn Research Center, Cleveland, Ohio

National Aeronautics and
Space Administration

Glenn Research Center
Cleveland, Ohio 44135

September 2007

Trade names and trademarks are used in this report for identification only. Their usage does not constitute an official endorsement, either expressed or implied, by the National Aeronautics and Space Administration.

This work was sponsored by the Fundamental Aeronautics Program at the NASA Glenn Research Center.

Level of Review: This material has been technically reviewed by technical management.

Available from

NASA Center for Aerospace Information
7115 Standard Drive
Hanover, MD 21076-1320

National Technical Information Service
5285 Port Royal Road
Springfield, VA 22161

Available electronically at <http://gltrs.grc.nasa.gov>

Feedback Control Systems Loop Shaping Design With Practical Considerations

George Kopasakis
National Aeronautics and Space Administration
Glenn Research Center
Cleveland, Ohio 44135

Abstract

This paper describes loop shaping control design in feedback control systems, primarily from a practical stand point that considers design specifications. Classical feedback control design theory, for linear systems where the plant transfer function is known, has been around for a long time. But it's still a challenge of how to translate the theory into practical and methodical design techniques that simultaneously satisfy a variety of performance requirements such as transient response, stability, and disturbance attenuation while taking into account the capabilities of the plant and its actuation system. This paper briefly addresses some relevant theory, first in layman's terms, so that it becomes easily understood and then it embarks into a practical and systematic design approach incorporating loop shaping design coupled with lead-lag control compensation design. The emphasis is in generating simple but rather powerful design techniques that will allow even designers with a layman's knowledge in controls to develop effective feedback control designs.

Introduction

Classical feedback control is challenging even to control designers, and translating the theory to easily understood and encompassing design tools is not an easy task. This is the reason that many control designers to date still employ ad-hoc control design techniques like normally done with PID control design. Such ad-hoc control design techniques primarily rely on manipulating the control gains to achieve some satisfactory time domain response, without much insight on how to achieve good overall performance within the limitations of the control design relative to the plant.

Being able to relate the hardware designs, such as the actuator speeds, into the controller design limitations is a practical matter, which can not be overlooked. In aviation systems actuators like hydraulics, are the means by which control is applied. If the control designer understands how these actuators influence the control design, better control designs can be achieved. Understanding this relation between the hardware and control designs also enables the control designer to negotiate the control requirements or justify the need for better (faster) actuators.

The idea of Loop Shaping in classical feedback control system design is not new. But there is not that much written about this subject in terms of methodical design techniques that simultaneously satisfy a variety of control requirements and also offer insight into the limitations of the control design in relation to the plant. References 1 and 2 discuss loop shaping in terms of sensitivity functions, but they do not present a methodical control design approach for loop shaping and a clear path of how the control design is related to the nature of the plant. There is also a considerable amount of work done in \mathcal{H}_∞ loop shaping (ref. 3 is an example of that). But with \mathcal{H}_∞ it is difficult to incorporate quantifiable stability requirements in the design for the computation of the control bounds (singular values). Also, satisfying the control bounds doesn't preclude the existence of a better control law that offers better performance, making it difficult to understand the limitations of the control design relative to the plant at hand and the requirements.

Other than ad-hock control design techniques, classical control techniques like Root Locus (ref. 4) is perhaps the most widely used linear feedback control design method. In root locus feedback control the poles and zeros can be placed to give a certain time domain response. But with root locus the correlation between the time and frequency domain responses can be described qualitatively at best and additional frequency domain analysis would be needed to quantify stability, disturbance rejection, and generally to understand the limitations of the control design process. On the other hand, a loop shaping design can accomplish all that and it can still remain in many regards a powerful and intuitive design process. The loop shaping control technique described here assumes that the plant transfer function is known. But other than that, the design methodology as described here is generally applicable.

In this paper some control concepts are mentioned occasionally, like lead-lag compensation, stability margins, closed loop gain (CLG), settling time and so on, without reference. These concepts are standard classical control concepts that can be found (for more information) in any book on linear control systems design, like reference 4.

The paper is organized as follows. A background of the theory relative to feedback control and loop shaping is first discussed in brief; the natural response of the system and the control bandwidth. Next the control design relative to the plant, more specifically the actuation system speed relative to the control bandwidth design is discussed. This is followed by the loop shaping design procedure; general guidelines, how to incorporate control system requirements into the loop shaping design, and how these requirements relate to design limitations. Lastly, the feedback controller design procedure is outlined relative to the loop shaping design and contrasted with more traditional designs like PID control, with the use of design examples.

Loop Shaping Control Design Background

This section discusses frequency domain closed loop control design, given a plant transfer function, actuator(s) rates, and time and frequency domain control design requirements like transient response, disturbance attenuation, and stability. The introductory discussion in this section may seem premature. But the aim is for the reader to keep the material in this section in mind when some background control concepts are presented later, followed by a more detailed discussion in this area.

A traditional feedback control system as shown in Figure 1, with a plant transfer function $G_p(s)$ and a controller transfer function $G_c(s)$ has input to output transfer function

$$\frac{C(s)}{R(s)} = \frac{G_C(s)G_P(s)}{1 + G_C(s)G_P(s)} \quad (1)$$

The CLG of the feedback control system in Figure 1 is

$$L(s) = G_c(s)G_p(s) \quad (2)$$

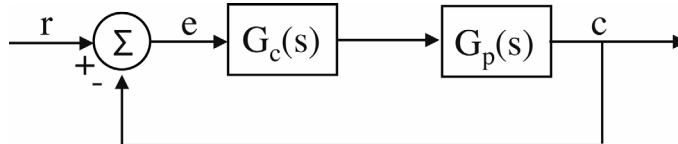

Figure 1.—Feedback Control System Diagram

In general, the CLG of a feedback control system is $L(s)=G_C(s)G_P(s)H(s)$, where $H(s)$ is the feedback transfer function. Loop shaping mainly consists of designing the frequency domain response of $L(s)$ to satisfy control system requirements and then given the transfer function of the plant $G_P(s)$, calculate or determine the controller transfer function $G_C(s)$, so that the desirable CLG transfer function $L(s)$ is realized. The reason for shaping the loop gain $L(s)$, is because the denominator of Equation (1), often referred to as the characteristic equation, is the equation that determines the stability properties of the feedback control system, as well as disturbance attenuation and response time characteristics.

A desired shape for CLG, $L(s)$, somewhat independent of the control system specifications is shown in Figure 2. Such a typical design would have a pole at the origin for high CLG and zero steady-state error, followed by a zero to maintain relative high gain at the mid-frequency range for disturbance attenuation, followed by a pole to attenuate the gain at higher frequencies in order not to exceed the actuator rate(s). Such a design would also have adequate stability margins $\geq 90^\circ$ phase margin and infinite gain margin since the phase doesn't cross 180° (more detail on stability margins will be discussed later). The loop gain displayed below is an example of that.

The feedback control diagram for this system is shown in Figure 3. The forward loop transfer function starting from the gain k to the transfer function output depicts the desirable CLG transfer function as opposed to normally separately displayed controller and plant transfer functions.

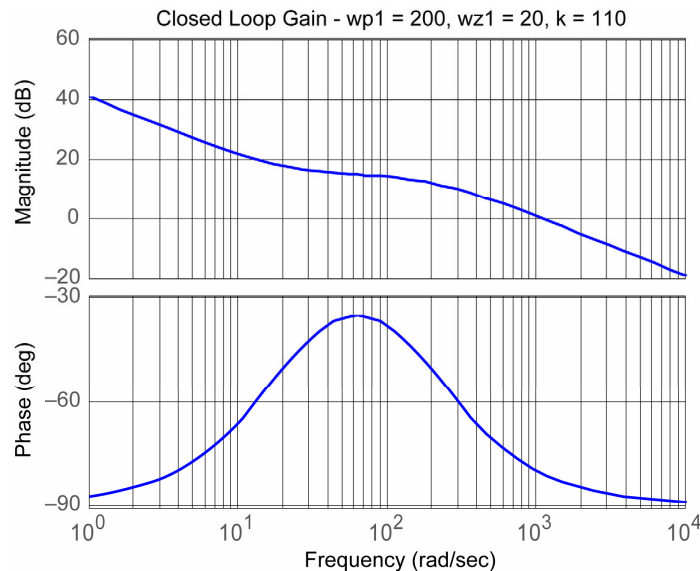

Figure 2.—Typical CLG Design of a Feedback Control System

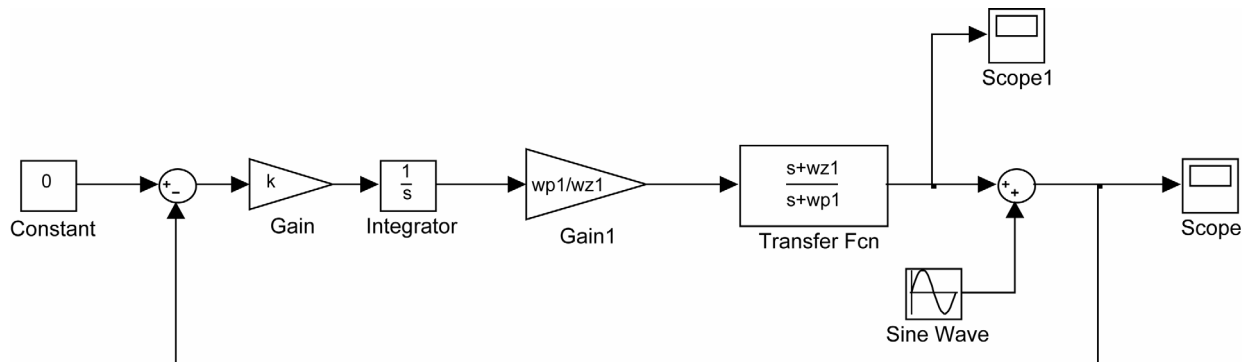

Figure 3.—Feedback Control Diagram for the CLG in Equation (2) and Figure 3

For this control diagram $L(s) = k \frac{wp1}{wz1} \frac{(s + wz1)}{s(s + wp1)} = 110 \frac{(s/20 + 1)}{s(s/200 + 1)}$ and the input to output transfer function in Equation (1) can be rewritten as

$$\frac{C(s)}{R(s)} = \frac{L(s)}{1 + L(s)} \quad (3)$$

Figure 2 can be reproduced by the following commands in MATLAB®

```
>> num=110*[1/20 1];
>> den=[1/200 1 0];
>> bode(num,den);
>> grid
```

Closed Loop Design Procedure Based on Specifications

A feedback controller design procedure would need to incorporate information of the speed of the actuators such that certain limits placed on actuator rates (i.e., magnitude response over time) will not be exceeded. Exceeding actuator rates can have negative consequences such as shortening the actuator lifetime. Also if the controller demands excessive actuator rates, with no limits placed, this can cause the controller to overdrive and saturate the system. If actuator rate limits are incorporated in the control design, hitting these limits causes the system to become nonlinear, which can complicate the control system analysis. To avoid these difficulties, the actuator rates can be incorporated in the control design right from the start, and incorporation of actuator rate limits could serve as last resorts, if for some reason the controller fails to do its job.

The control system design must also have the ability to attenuate low frequency disturbances. As is often the case with control systems, disturbances or noise to the system can not be totally avoided. Thus a good control design also deals with the system disturbances, within the capability of the actuation hardware. Sometimes attenuation requirements, as all other control requirements, can be explicitly stated or else they become implicit in the design process. Knowing how to design the control system in a systematic way, within the capability of the hardware actuation system, can empower the control system design engineer to ask for more hardware capability in order for the control design to meet system requirements or negotiate requirements.

Natural Frequency of Closed Loop Systems

Before we embark into a feedback control design process using loop shaping design, some fundamental concepts need to be introduced first to help facilitate the discussion.

In order to incorporate the actuator rates into the feedback control design, it is important to understand the natural response or the natural frequency of feedback control systems. The response of a linear sufficiently damped dynamic system to a unit step input can be approximated with an exponential response as

$$c(t) = (1 - e^{-\omega_n t}) \quad (4)$$

where ω_n is the natural frequency of the system.

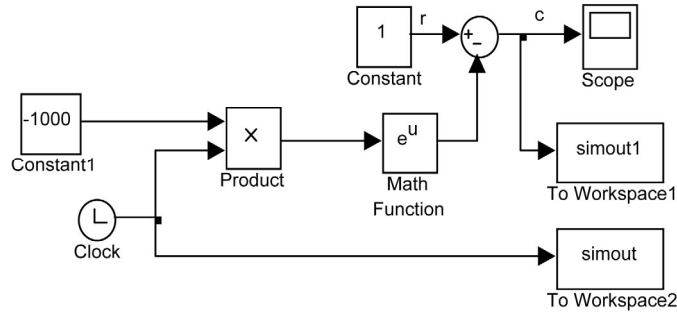

Figure 4.—Exponential System Simulation—Approximation to a Damped Dynamic System Response

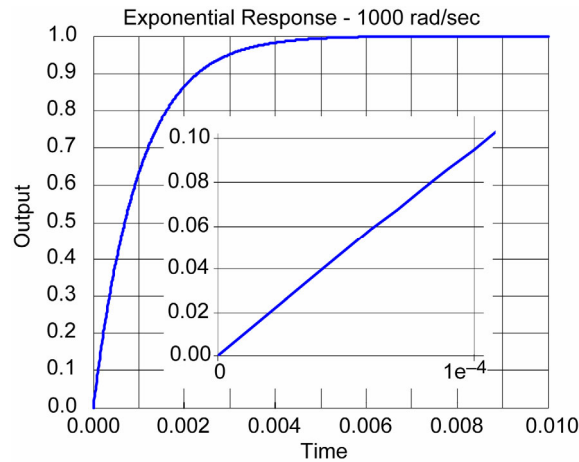

Figure 5.—Exponential Response

Figure 4 shows the simulation of Equation (4) and Figure 5 shows the exponential response and the rate. The rate of the system is $\sim 0.1/1e-4 = 1000$, which is the same as ω_n in the simulation. For this approximation to a dynamic system, this rate would be the rate at which the actuation system would also need to respond to control the system. The simulation shown in Figure 4 was done using SIMULINK[®] and the plot was produced with the following command in MATLAB[®]

```
>> plot(simout.signals.values',simout1.signals.values')
```

The question becomes what is the natural frequency of a dynamic system. For first and second order systems of the type

$$\frac{C(s)}{R(s)} = K \frac{\omega}{s + \omega} \quad (5)$$

or

$$K \frac{\omega^2}{s^2 + 2\zeta\omega + \omega^2} \quad (6)$$

the natural frequency is ω . For a feedback control system (Eq. (3)), however, the natural frequency of the system is not so obvious. The closed loop system response can be expressed in terms of magnitudes. The output reaches the magnitude of the reference input, in a step response, when the $|C(j\omega)| \equiv |R(j\omega)|$ or

when the output ratio $\left| \frac{C(s)}{R(s)} \right| \cong 1$. Based on that the system response in Equation (3) approaches unity when

$$\left| \frac{C(s)}{R(s)} \right| \cong \frac{|L(j\omega)|}{|1 + L(j\omega)|} \cong 1 \quad (7)$$

For the transfer function in Equation (7), the natural frequency would be the frequency where the response breaks from the horizontal asymptote (rolls off 3 dB from the magnitude it starts out - typically the magnitude starts out at 1 (0 dB). But the question still remains what is the frequency where the magnitude of Equation (7) rolls off 3 dB in magnitude. As it is often the case in feedback control design, the CLG L employs an integrator to drive the steady-state error to zero and also to accomplish high disturbance attenuation at low frequencies. For an integrator in the control design, as $s \rightarrow 0$ (equivalently as $t \rightarrow \infty$) the magnitude ratio in Equation (7) becomes unity. But in determining the natural frequency of the closed loop system, we are not interested what happens in the limit sense, after all the modes have settled. Rather, the interest is to find the point when the magnitude ratio first starts to approximate unity, starting from $s = \infty$ (equivalently starting from $t = 0$). By inspection of Equation (7), it can be seen that the ratio first starts to approach unity when $|L(j\omega)| \cong 1$ and $|1 + L(j\omega)| \cong 1$. Remember from controls theory that when t equals one time constant, $\tau_c = \frac{1}{\omega_n}$, the system response reaches $1 - e^{-1}$ or 63% of its final value. Also, $|1 + L(j\omega)|$ is a vector summation and for instance, when $L(j\omega) = 1 \angle 120^\circ$ or 60° phase margin (stability will be discussed later), then $|1 + L(j\omega)| = 1$. Therefore, the natural frequency of the closed loop system (for all practical purposes) is the frequency where the CLG L crosses the 0 dB axis in frequency (or magnitude of 1). This cross-over frequency is commonly referred to as the bandwidth of the system.

As an example consider the feedback control system shown in Figure 3. In this system a CLG has been designed as

$$L(s) = K \frac{wp1}{wz1} \frac{s + wz1}{s(s + wp1)} = K \frac{(s/wz1 + 1)}{s(s/wp1 + 1)} \quad (8)$$

This rather simplified CLG does not necessarily imply that either the plant transfer function or the controller design is trivial. Instead, as it will be discussed later, the shape of the CLG can be chosen to satisfy system performance criteria. Once this is done, the controller can be calculated (also by knowing the plant transfer function). The bode plot of the CLG in Equation (8), with $K=110$, $wz1=20$ and $wp1=200$, is shown in Figure 6 as well as the corresponding closed loop transfer function (CLTF) gain of Equation (3). It can be seen in this figure that the 3 dB roll-off frequency coincides with the cross-over frequency of the CLG. This establishes the relation in terms of natural frequencies between the CLTF and the CLG, which is our main interest here for loop shaping control design. This figure also demonstrates why it makes sense to shape the CLG instead of the CLTF and that is because unlike the CLG, the CLTF is inherently flat in most of the frequency range of the control design. Figure 7 shows the response of the system to unit step input and the initial rate of the system which is approximately 1000, the same as the cross-over frequency of the CLG in Figure 6.

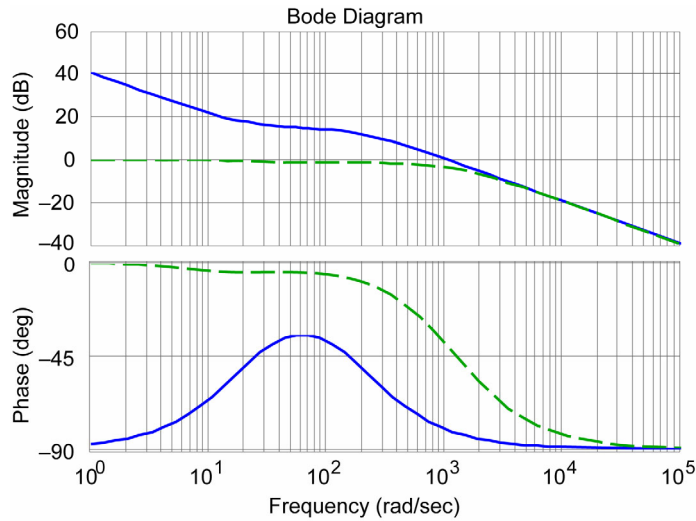

Figure 6.—Bode Plot of the Closed Loop Gain $L(s)$

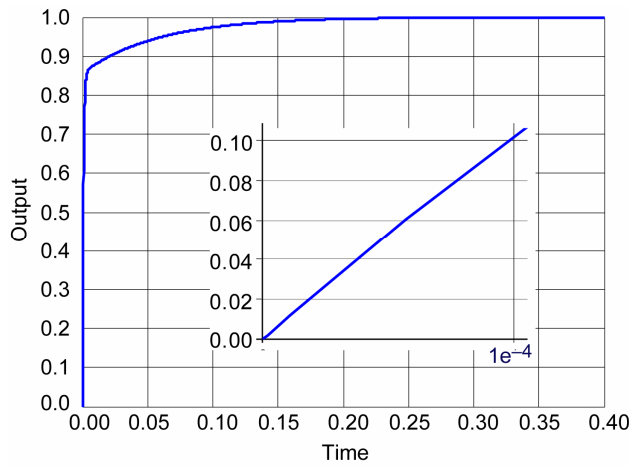

Figure 7.—Closed Loop System Response to a Unit Step

This simulation in Figure 6 was produced with the following additional commands (i.e., additional to the commands used for Figure 2) in MATLAB®

```
>> num2=1100*[1 20];
>> den2=[1 1300 22000];
>> hold on;
>> bode(num2,den2)
```

The num2 and den2 values were obtained by calculating Equation (3) with the corresponding values of $L(s)$, which reduces to $\frac{C(s)}{R(s)} = \frac{L(s)}{1+L(s)} = \frac{1100(s+20)}{s^2+1300s+22000}$. Using actuator rate limit spec(s) and

with the understanding of the natural frequency ω_n of a closed loop control system discussed above, the design of the feedback controller can begin. But first a little more discussion is needed to more fully understand the natural response of a closed loop control system. The natural frequency of the closed loop control system also depends on the lowest frequency zero of the CLG, $L(s)$. The role that the lowest frequency zero plays in the response of the system is that the frequency of the zero in *rad/sec* becomes the time constant $1/\omega_z$, which is the time it takes for a pole in the system to reach that lowest frequency zero.

Therefore, this zero also influences the response of the system. Both the cross-over frequency time constant and the time constant of the lowest frequency zero will influence the overall time response of the system. The cross-over frequency of the system, which would be normally higher than the frequency of the lowest frequency zero, will therefore, influence the initial response of the system. The lowest frequency zero will dictate the final response of the system before the system response settles. If it turns out that the CLG has no zero below the cross-over frequency, then the system time response will only depend on the cross-over frequency. However, a zero placed before (actually well before) the cross-over frequency is a good design practice because it helps to boost the mid-frequency gain for disturbance rejection, increase the phase margin for stability, and also increase the control bandwidth.

Figure 8 shows a portion of Figure 7 that emphasizes the response of the closed loop system that is influenced by the natural frequency of the lowest frequency zero. The time constant of this natural frequency is $\tau = 1/\omega_{z1} = 0.05 \text{ sec}$. In Figure 8, the response due to the natural frequency of the zero starts when the output reaches approximately 0.85. Thus in 1 time constant, starting from when the response reaches 0.85, the output should reach, $0.85 + (1 - 0.85) \times 0.63 = 0.944$, which is about right. The shape of the second order response in Figure 7 may not be typical compared to customary, smooth damped responses as shown in Figure 5. But it serves two purposes; one is to help maintain high mid-frequency gain (see Figure 6) to attenuate disturbances, as will be discussed later; two it helps the stability of the system by boosting the phase (full $+90^\circ$) before the cross-over; besides the fact that it also serves the purpose here to separate and illustrate the natural frequencies of closed loop systems. If this system did not have sufficient phase margin, the response of the system would have been underdamped and the response due to the lowest frequency zero would have been masked out (i.e., if there was any visible evidence left it would be further out in time just before the response settles).

Incorporating Actuator Rates in the Feedback Control Design

As was discussed above, the cross-over frequency of the system (normally higher than the frequency of the lowest frequency zero) determines the initial response of the closed loop system. The system response rate (magnitude response over time) at the initial stages of the response is approximately equal

to $\tau_{co} = \frac{1}{\omega_{co}}$ for a unit step input, where τ_{co} is the time constant of the cross-over frequency ω_{co} . For a

non-unit step response, the initial system response rate would be r_m/τ_{co} , where r_m is the maximum allowable magnitude of the step input. For the actuator limit not to be exceeded, r_m/τ_{co} is set equal to the

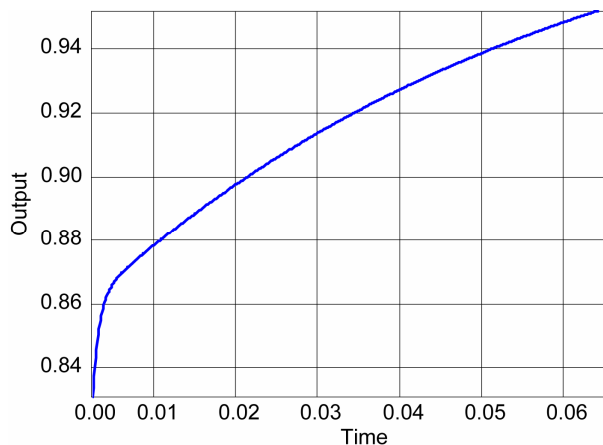

Figure 8.—Closed Loop System Response to a Unit Step Expanded to Show the Natural Response Due to Closed Loop Zero

actuator rate limit, a_{rl} (a_{rl} is magnitude units per sec). Therefore, the cross-over frequency, ω_{co} , can be computed based on the actuator rate limit and the input step size as $\omega_{co} = a_{rl} / r_m$. If there is other than one-to-one correspondence between the actuator control rate and system response rate than the computed cross-over frequency would need to be adjusted as

$$\omega_{co} = C_r a_{rl} / r_m \quad (9)$$

where $C_r = c_r / a_r$ is the rates ratio of system output response with respect to the actuator input. In case the rate limiting factor is not the actuator itself, but rather it is the mechanical device that the actuator controls, then this mechanical device becomes the effective rate for the calculations involving the actuator rate. It is not necessary to specify the system with only step input responses, it could be a ramp instead; in case of a ramp, if the ramp rate is faster than the actuator rate the ramp input can be treated like a step for this analysis; if the ramp rate is slower than the actuator rate, then the ramp input will not be a limiting factor for calculating the system bandwidth, ω_{co} .

The control system can respond to disturbances (i.e., attenuate disturbances) with frequencies up to the system bandwidth, ω_{co} . That is why *system bandwidth* is a commonly used term in control systems. If no input step response or ramp input characteristics are specified, or if the ramp input is not a limiting factor compared to actuator rate limit, then the bandwidth of the system can be tailored to disturbance attenuation requirements. Sometimes control design requirements are not explicitly stated, but in such cases control requirements become implicit in the design process. In some control system designs, the primary purpose is to maintain the output at a scheduled reference point and the controller design emphasis is to attenuate disturbances. In such cases, disturbance attenuation with actuator control rates could be used to determine the control bandwidth. In classical feedback control systems, where noise or disturbance is summed at the output, the output-to-noise transfer function is

$$\frac{C(s)}{N(s)} = \frac{1}{1 + L(s)} \quad (10)$$

where N is the noise input or disturbance to the system. Comparing this transfer function to Equation (3), it can be seen that the analysis for determining the natural frequency or the desired bandwidth of the closed loop system is the same for the system input as it is for the noise. Even if the noise summation occurs at a different place (i.e., somewhere else than at the systems output), the numerator of Equation (10) changes, but the analysis is still valid. Based on that, for a step or a ramp type disturbance (i.e., knowing the maximum magnitude of the disturbance) the same design considerations would apply for calculating ω_{co} as those discussed for the input step and input ramp. Figure 9(a) shows a closed loop step response to a unit step input followed by a unit step disturbance applied at 0.2 sec, for the same system shown in Figure 3. Both the responses (i.e., the response to the input and the response to the disturbance) are similar. Figure 9(b) which is an expanded part of Figure 9(a), shows that the control rate (actuation rate) due to the response of the disturbance is the same as that for the unit step input shown in Figure 7.

Also, it can be seen from Equation (10) and Figure 6 that the control system can attenuate disturbances to varying degree up to the cross-over frequency, as $|L(j\omega)| > 1$ below this frequency. Above the cross-over frequency $|L(j\omega)| < 1$ the response to noise in Equation (10) becomes unity and no disturbance attenuation can be expected above this frequency.

For a unit amplitude sinusoidal disturbance the controller can be designed with a bandwidth the same as that determined based on the unit step input and the actuator rate. Then the system can attenuate unit magnitude sinusoidal disturbances up to the frequency ω_{co} without exceeding the actuator rate limit. But if design specs call for sinusoidal disturbance of frequency ω_{co} , other than unit magnitude, then the unit step input design considerations can be employed again, and the

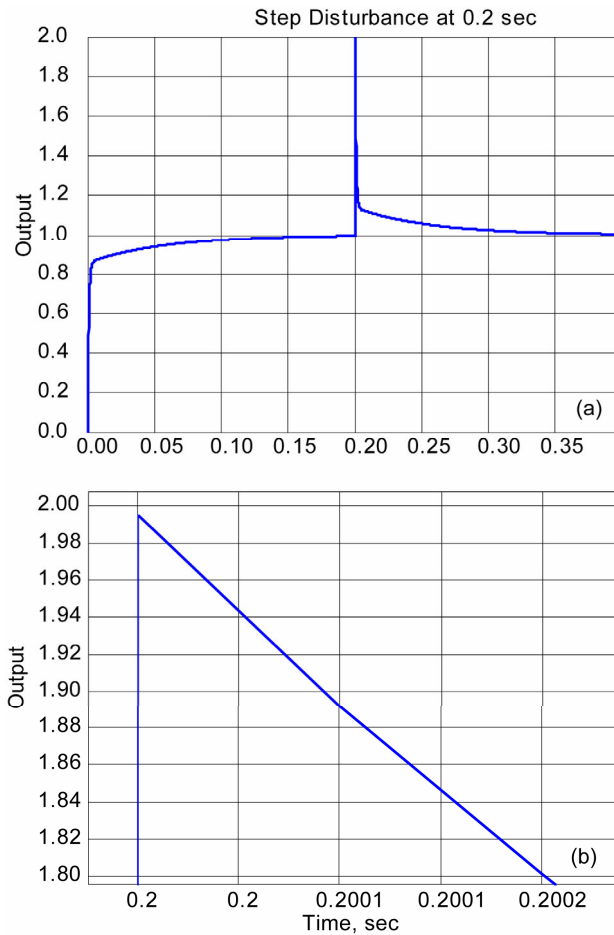

Figure 9.—(a) Closed Loop Control Response to a Unit Step Followed by a Unit Step Disturbance; (b) Expanded view of Disturbance Response

cross-over frequency should be adjusted based on Equation (9). Especially if the sinusoidal disturbance exceeds unity in order not to exceed the actuation rates. So knowing or anticipating what are the magnitudes, frequency, and attenuation requirements for disturbances together with the actuator rates, the design of the control system can proceed. For explicit sinusoidal disturbance attenuation specifications, the design procedure will be discussed later.

In terms of how much the controller can attenuate disturbances below the cross-over frequency, the attenuation magnitude is equal to the CLG $|L(j\omega)|$, at that particular frequency based on Equation (10). Near the cross-over frequency the attenuation is equal to the magnitude $|1 + L(j\omega)| \approx 1$. And beyond that there is not attenuation as $|1 + L(j\omega)| \approx 1$. For the feedback control system discussed above, a sinusoidal disturbance of 50 rad/sec is simulated. According to Figure 6, the magnitude of the CLG is ~ 16 dB at that frequency. So we can expect that a disturbance at this frequency will be attenuated by about $10^{16/20} = 6.3$ (the dB magnitude is based on $20\log_{10}(x)$). Figure 10 shows the disturbance with amplitude of 1 and the output response due to this disturbance with amplitude of about 0.15, which is what was expected out of the performance of the system. Next a disturbance is simulated right at the cross-over frequency of 1000 Hz, where we expect to see practically no attenuation. In Figure 11 we see that the attenuation of the control system at this frequency is instead about $1/0.64 = 1.56$. As was discussed before, it can be considered that a control system can attenuate disturbances up to the cross-over frequency, with practically no attenuation provided at the cross-over frequency. But what is the exact attenuation at the cross-over frequency depends on the stability margins of the system at this point. For instance, for this system the phase of the system at the cross-over frequency is about 77° according to Figure 6. Thus the

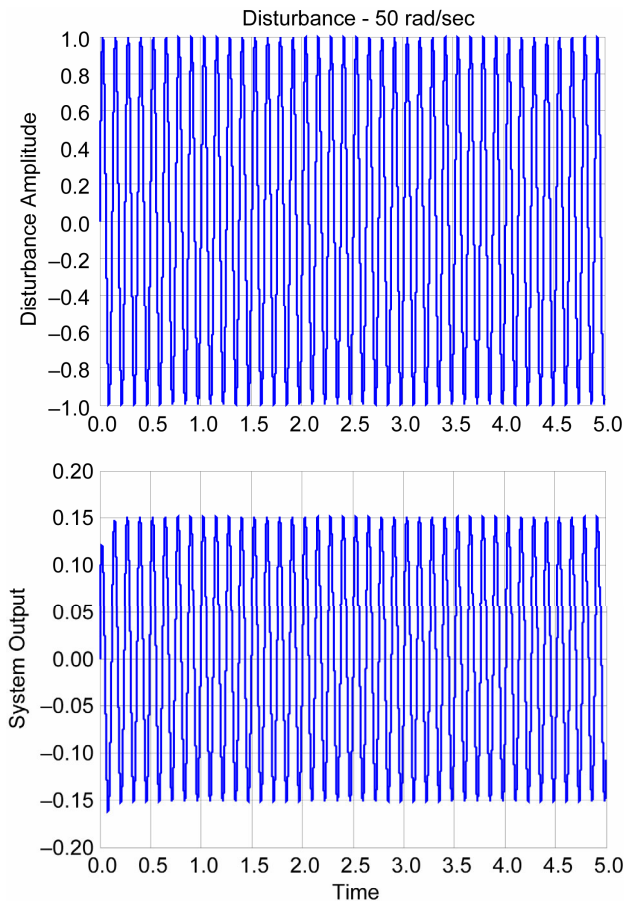

Figure 10.—Disturbance Attenuation of the Control System at 50 rad/sec

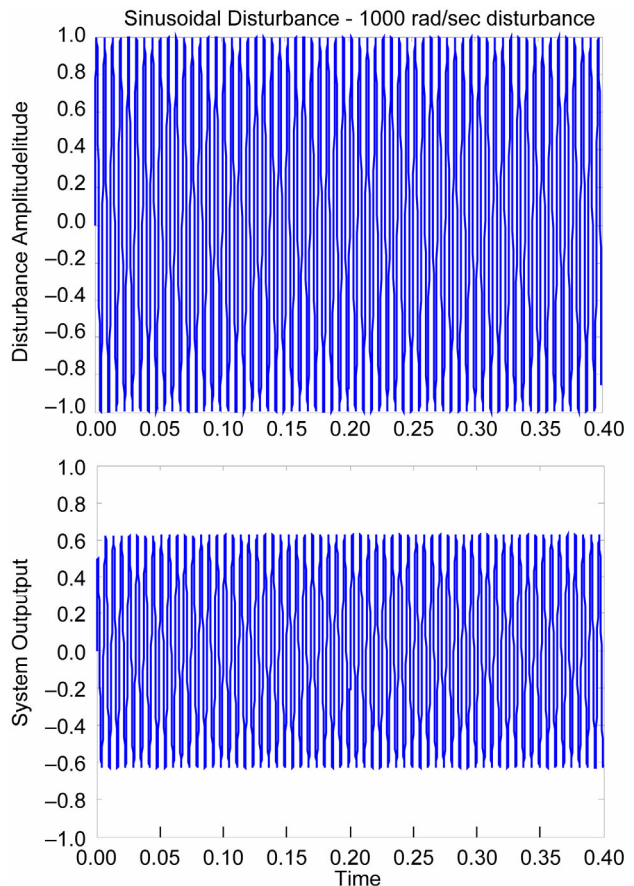

Figure 11.—Disturbance Attenuation of the Control System at 1000 rad/sec

magnitude of the denominator in Equation (10) is $|1 + L(j\omega)| \cong |1 + 1 \times 103^\circ| = 1.55$. This means that at this frequency, according to Equation (10), any disturbance will be reduced or attenuated by a factor of about 1.55, which agrees with the simulation results in Figure 11.

Control System CLG Shaping

So far the ground work was laid on how to handle control system actuation rates and determine the limits of the control bandwidth or cross-over frequency. Also, some discussion was carried out as to how the magnitude of the CLG influences disturbance attenuation at different frequencies. Next attention will be paid to the CLG design influenced by explicit or implicit control design requirements.

As discussed earlier the CLG can be designed or shaped based on explicit or implicit control system requirements such as actuation rates, disturbance attenuation, stability, and maybe transient response. Once the desired shape of the CLG has been derived, the feedback controller can be computed (covered in the next section) by also taking into account the plant transfer function.

In order to understand how to shape the CLG based on disturbance attenuation or rejection requirements, we must first understand the limits of the control system design. That is what would be the achievable disturbance rejection given the control system bandwidth, which has been determined based on actuation system rates. Let's say that the actuation system response rate limit and the input or disturbance step or rate calls for a control system bandwidth not to exceed 1000 rad. Also, let's say that additional disturbance requirements call that a disturbance at 100 rad needs to be attenuated by 20 dB or by a factor of 10. In that case, if we design the mid-frequency gain to be 20 dB and we place a pole at 100

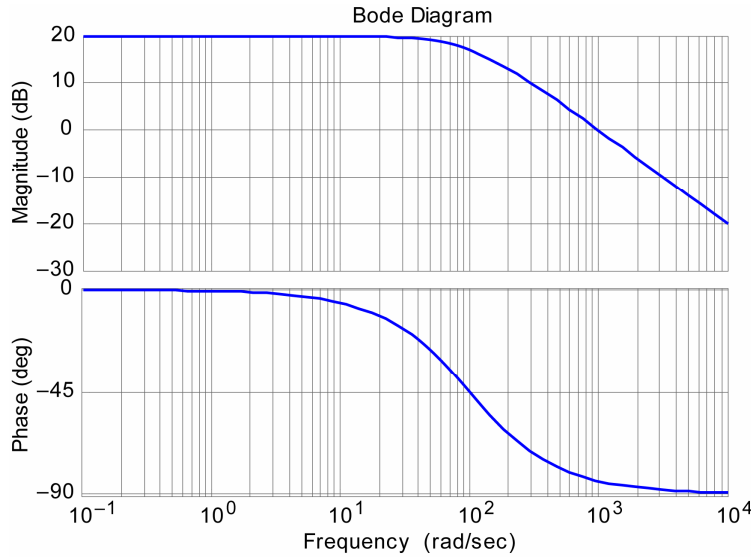

Figure 12.—Bode Plot of Closed Loop Gain Shaping with 20 dB Gain at Mid-Frequency and Cross-over (Bandwidth) of 1000 rad/sec

rad, then the CLG will cross the 0 dB axis at 1000 rad (how we go about designing the lower and mid-frequency gain will be discussed later). Remember, that a pole gives a slope of -20 dB/decade (a zero will give a slope of $+20$ dB/decade) starting at the frequency where the pole is placed. This means that a pole placed at 100 rad where the gain is 20 dB will bring the gain to zero at 1000 rad. Figure 12 shows this portion of the design with

$$L(s) = 10 \frac{100}{s + 100} \quad (11)$$

In reality as shown in Figure 12, at the frequency where the pole is placed the gain rolls off by 3 dB, and for a zero the gain will be up by 3 dB. For this design, this means that for the gain to cross-over at 1000 rad the actual gain at 100 rad will be 17 dB instead of 20.

If we continued with this design and we selected to put a zero somewhere at low frequency (i.e., less than 100 rad), and a pole at zero, then the phase at cross-over would be expected to be -90° (i.e., -90° - pole at origin, $+90^\circ$ - zero at low frequency -90° pole at 100 rad/sec). This will give sufficient phase margin for stability, as typically greater than 60° will be adequate (somewhat damped response). The phase margin for stability is defined as $M_\phi = 180 - |\phi|$, where ϕ is the phase of the CLG at the cross-over frequency.

Now let's say that instead of 20 dB attenuation at the mid-frequency range, 17 dB at 100 rad/sec with the same cross-over frequency, the requirement was for 26 dB or a factor of 20 in disturbance attenuation. We can still cross-over at 1000 rad/sec if an additional pole is placed at 500 rad/sec. The reason is, that a pole gives a reduction in gain of 20 dB/decade or 6 dB/octave (1000 rad/sec is one octave above 500 rad/sec). Therefore, the pole at 100 rad/sec gives us 20 dB gain reduction at 1000 rad/sec with an additional 6 dB contribution from the pole at 500 rad/sec, which gives us a total of 26 dB reduction at 1000 rad/sec that meets the requirement. But we need to also check the phase margin with this design. From before, we had 90° phase margin. Adding the phase contribution of the additional pole at 500 Hz, we will get 45° contribution at 500 Hz (the phase of poles and zeros starts one decade below the frequency and ends about one decade above - total 90° shift) and approximately another 14° contribution one octave away, at 1000 rad/sec. Thus, this design will make the phase margin about $180 - 90 - (45 - 14) = 31^\circ$. This design will not satisfy typical stability requirements, and the response will start out somewhat oscillatory with little margin for error. Therefore, while 20 dB mid-frequency gain (17 dB gain

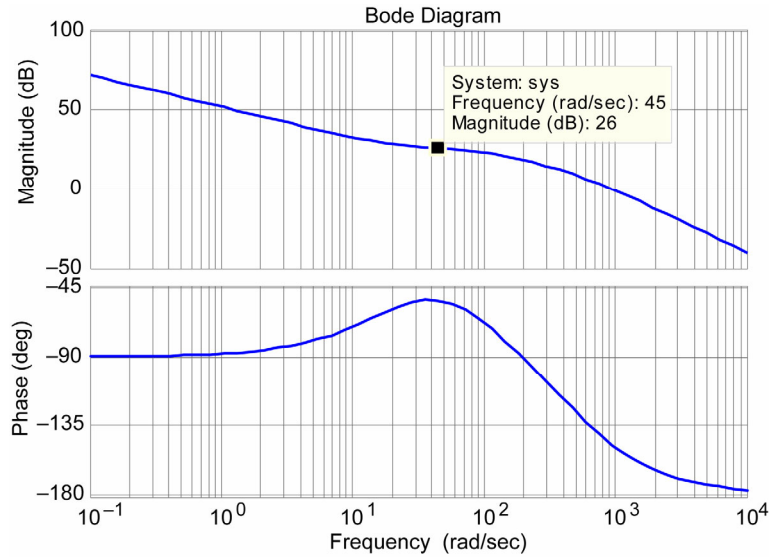

Figure 13.—Closed Loop Gain with Cross-over at 1000 rad/sec and 26 dB mid-frequency gain

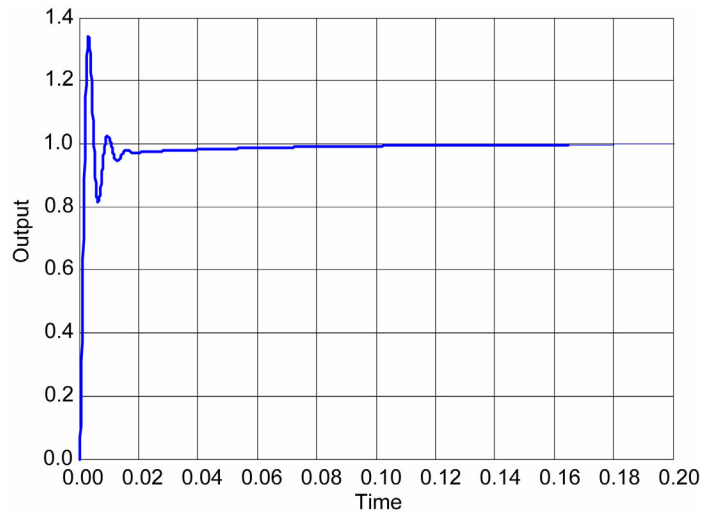

Figure 14.—Response of the closed Loop System with 1000 rad/sec cross-over, 26 dB mid-frequency gain (phase margin ~ 31°)

one decade below the cross-over frequency due to the pole roll-off) is reasonable for the control system design for disturbance attenuation, 26/23 dB exceeds the capabilities of a feedback control system. The limit of the control design is somewhere between the 20 and less than 26 dB mid-frequency gain, depending on what are the stability requirements that includes the gain margin. Gain margin is the gain difference between the cross-over frequency gain (i.e., the 0 dB gain) and when the CLG $L(j\omega)$ crosses 180°. Figure 13 and Figure 14 show the CLG of such a design and the closed loop response (i.e., with cross-over of 1000 rad/sec and mid-frequency gain of 26 dB) as

$$L(s) = K \frac{(1/wz1 + 1)}{s(s/wp1 + 1)(s/wp2 + 1)} \quad (12)$$

For this case, $K=400$, $wz1=20$, $wp1=100$, $wp2=500$. Note: the response in Figure 14 has significant overshoot and typically it would not be acceptable. But it serves the tutorial purpose here of demonstrating the control design limitations.

The low frequency zero dictates the final time response of the closed loop system as was discussed earlier. If the plant transfer function has a zero at lower frequency, but that zero doesn't show up in the CLG transfer function because a pole has been placed on top of this zero, still that low frequency zero will dictate the final time response of the system. Sometimes the overall time response of the system is specified, which dictates the placement of the low frequency zero. Other times it is left up to the control system designer to design the speed and the settling time with which the system responds, within the capabilities of the plant. If the overall response of the system is not specified, the lowest frequency zero in the CLG needs to be placed at a frequency less than a decade below the cross over frequency. This is done in order to get the full benefit of $+90^\circ$ phase shift to help with stability. Then the zero can be placed as low in frequency, without compromising the final speed/settling time with which the system needs to respond, and to maintain a high mid-frequency gain for disturbance rejection.

Of course, the pole at the origin is important for zero steady-state error and also for high CLG at low frequencies for disturbance rejection. In practice, it is also beneficial to place another pole, as in Equation (12), shortly before or after the cross-over frequency, which causes the gain to decrease by 40 dB/decade starting from that point in frequency. The reason is that if any unmodeled plant zero exists in this frequency range shortly after cross-over, even if it does not compromise system stability (i.e., *absolute stability* – defined at singular frequency, at the cross-over) as was discussed earlier, it can compromise *conditional stability*; the gain (lingering) near the neighborhood of the cross-over frequency or equivalently near the -1 radius circle on the Nyquist plot (where system stability again depends on the phase).

Loop Shaping Design Procedure: Example

For demonstration of loop shaping design let's pick a design example with the following control system design requirements:

Actuation rate limit to a unit step input, for a one-to-one control to output ratio – 1000 per second

Mid-frequency disturbance attenuation of 23 dB/20 dB at 100 rad/sec

Stability phase margin of $\geq 45^\circ$ and gain margin of ≥ 10 dB

One time constant response time ≤ 0.02 sec

Settling time to 2% error of ≤ 0.1 sec

Notice, an overshoot requirement was not given in this example. Had we also been given an overshoot requirement, this would be somewhat redundant with the phase margin requirement. That is because the 45° requirement translates to the magnitude of the CLTF vector representation of $|1/(1 \angle 0^\circ + 1 \angle 135^\circ)| = |1/0.765| = 1.307$ or 30.7% overshoot. This calculation can be used as a rough approximation for overshoot, or an explicit overshoot requirement could be given for completeness. However, the stability requirement as listed here, alone, would not guarantee stability and we're not talking here about system sensitivity. That is because the $45^\circ/10$ dB requirement refers to *absolute stability* as mentioned before and doesn't cover *conditional stability*. More on this topic will be discussed later in this section.

Based on these requirements we first calculate the cross-over frequency based on Equation (9), $\omega_{co} = C_r a_{r1}/r_m$ with $C_r = 1$ and $a_{r1} = 1000$ units/sec, which gives us $\omega_{co} = 1000$ rad/sec. Based on the mid-frequency disturbance attenuation requirement of 23 dB; with mid-frequency CLG design of 23 dB, we can place a pole at 100 rad/sec which will reduce the gain by 20 dB at 1000 rad/sec. If we put another pole at 1000 rad/sec, this is expected to reduce the gain by another 3 dB at this frequency (remember a pole reduces the gain by 3 dB at the frequency where it is placed. With a pole also placed at the origin and a zero placed somewhere below 100 rad/sec, we would expect to have a phase at cross-over of $\phi_{cr} = -90 + 90 - 90 - 45 = -135$, which gives a stability phase margin of $M_\phi = 180 - |\phi_{cr}| = 45^\circ$. This meets the stability phase margin requirement. This design would meet the gain margin requirement as well (infinite gain margin) since the phase does not cross the 180° axis.

The next question is at what frequency to place the zero. Remember the lowest frequency zero also influences the time response. The one time constant response time of 0.02 sec, which happens to be approximately 63% of the final value of the response can easily be met in this design, since this time constant, τ_c , is primarily influenced by the cross-over frequency and $\tau_c \approx 1/\omega_{co} = 0.001$. So this requirement does not influence the placement of the closed loop zero. Looking into the settling time requirement of 2% error within 0.1 sec; a 2% error requirement in controls theory for a dominant second order response is achieved within 4 time constants. Assuming, that the low frequency zero is well below the cross-over frequency (as is the case here), so that the two time constants in the response are separated, and assuming that the low frequency zero starts dominating the response after the response reaches about 80% of its final value, then this 2% error would translate to $0.02/(1-0.8) \times 100\% = 10\%$ error criteria on the lowest frequency zero. Again from controls theory, this translates to about 2 time constants for the lowest frequency zero. Also, the 80% response due to the cross-over frequency time constant takes about 0.002 sec. Therefore, 1 time constant (τ_{cz}) for the low frequency zero based on the settling time specification would be $\tau_{cz} = [(0.1 - 0.002)/2] \approx 0.05 \text{ sec}$ and the zero frequency would be $\omega_z = 1/\tau_{cz} = 20 \text{ rad/sec}$. Thus, we could place the zero at 25 rad/sec to leave some margin. Of course, the design would need to be simulated and make any final adjustments if necessary.

Also, as customary in feedback control design, a pole will be placed at the origin for the reasons discussed before. For the gain, K , of the CLG transfer function, we know that the spec calls for 23 dB mid-frequency attenuation for disturbance. Therefore, at the zero frequency of 25 rad/sec the gain of the CLG transfer function needs to be 23 dB as

$$|L(j\omega)| = \left. \frac{K}{s} \right|_{j\omega=25} = 23 \text{ dB} \quad (13)$$

which gives $K = (25)10^{23/20} = 353.13$. In actuality because the zero breaks 3 dB above (as discussed) before, the gain of the transfer function would be 26 dB at the frequency of the zero. A simulation of $L(s) = K(s/25 + 1)/s$ is shown in Figure 15.

At this point based on the requirements provided, we have designed the CLG transfer function $L(s)$ as

$$L(s) = 353.13 \frac{(s/25 + 1)}{s(s/100 + 1)(s/1000 + 1)} \quad (14)$$

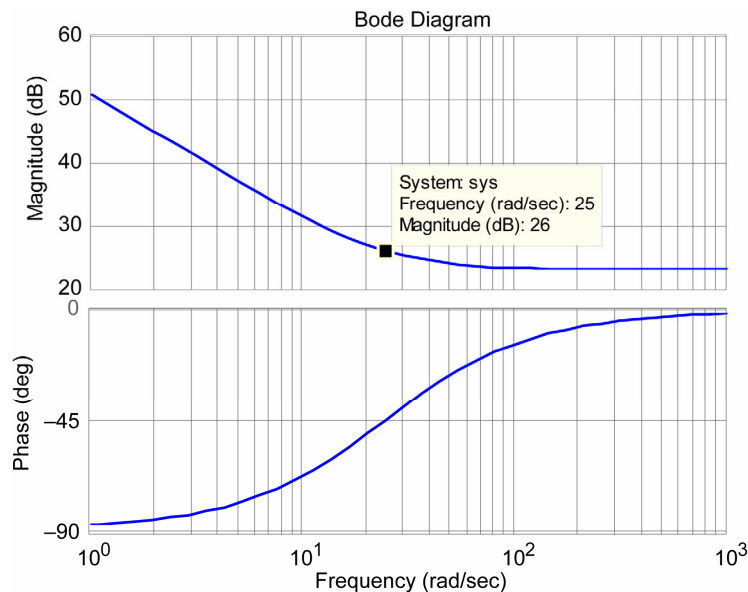

Figure 15.—Bode plot of the Closed Loop Gain Transfer Function, $L(s) = K(s/25 + 1)/s$

Figure 16 shows the bode plot simulation of the designed CLG $L(s)$ in Equation (14), which meets the requirements in terms of mid-frequency gain for disturbance attenuation, cross-over frequency for actuation rate and stability phase and gain margins, and also very closely conforms with the design procedure. One thing that remains is to check if the design meets the time requirements for a step response and the actuation control rate. Figure 17 shows the time response of this design to a unit step input. As seen the response is somewhat underdamped due to the low phase margin. The system well meets both the one time constant response time as well as the 2% settling time spec within 0.1 sec. In fact, as shown in Figure 17, the error is approximately 0.5% at 0.1 sec. We assumed before in the design that the two natural frequencies in the response are separated or distinct and that the response due to the zero starts about when the response reaches 80% of its final value. However, that assumption was incorrect due to the underdamped nature of the cross-over frequency mode which dominates the response beyond

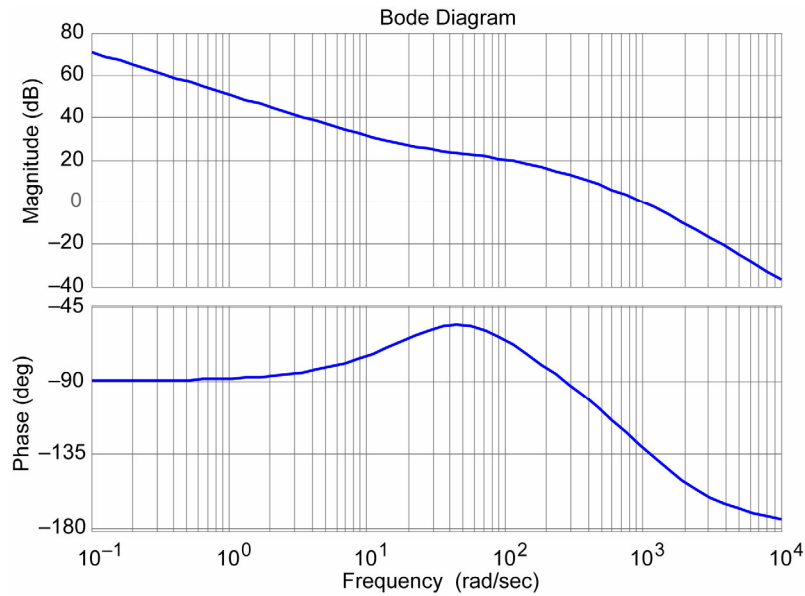

Figure 16.—Designed Closed Loop Gain of equation (14)

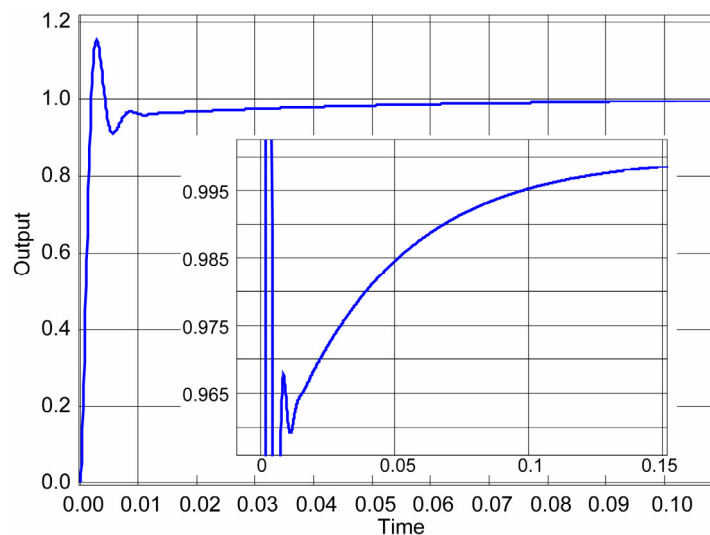

Figure 17.—Step Response of the Designed Closed Loop System

80% of its final value. This means that for this system the zero can be moved at a lower frequency and the system still meets the time response requirements. The maximum system rate (actuation rate) as shown in Figure 18 is about 500 units/sec. as opposed to 1000 for which the cross-over frequency was designed for, seemingly due to the additional integration (additional pole compared to Figure 7). As a result, the cross-over frequency could possibly be moved higher, which would improve the design margins. With the cross-over frequency selected, designing to increase phase margin and also increase mid-frequency disturbance attenuation work against each other. Had it not been for the slowing of the response (actuation) rate in the process as shown in Figure 18, the design specs would have constitute the limits of what a control design can do given the actuation rate, mid-frequency disturbance attenuation, and any, even slightly reasonable phase margin. This is why this example was chosen to also demonstrate control design limitations.

Figure 19 shows an encompassing specification of system stability (i.e., it includes both absolute and conditional stability), in that it specifies an exclusion zone inside which the trajectory of the CLG is not allowed. This exclusion zone (offered as an example) is bordered by the lines of 60° phase margin and 6 dB gain margin (equivalent to 0.5 radius circle). Note: the gain margin for the exclusion zone does not

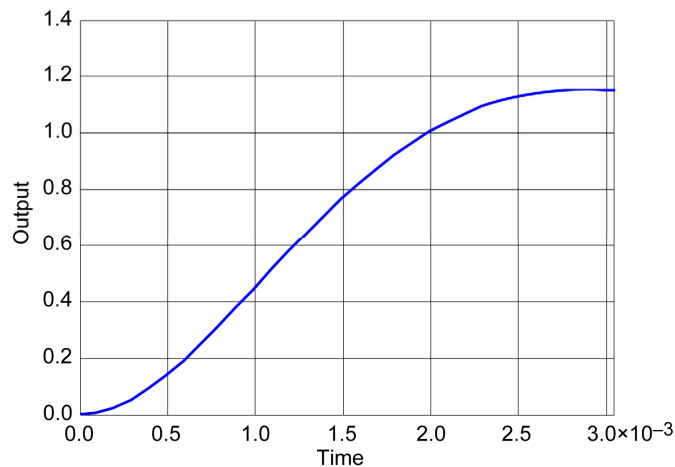

Figure 18.—Step Response to Show System Rate

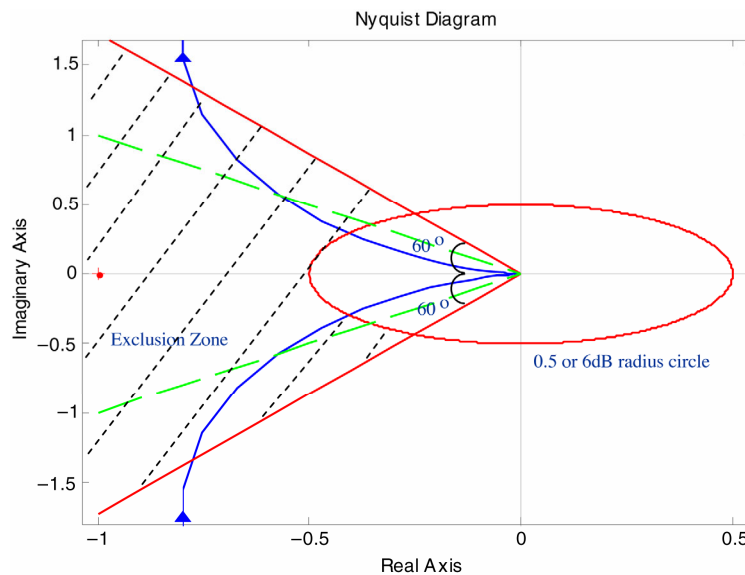

Figure 19.—Nyquist Plot Showing Exclusion Zone for Stability Specifications and the Trajectory of the CLG in Equation (14)

have the same interpretation as the gain margin for absolute stability. The plot also shows the trajectory of Equation (14), which in this case does not satisfy this exclusion zone criterion for stability. For comparison the 45° phase margin lines are also shown in green color. The Script for generating this Nyquist plot is covered in Appendix I. Generally speaking, if there are no resonances evident near the cross-over frequency of the CLG (the requirement can call for no resonance in the CLG), as in Figure 16, stability should be fine only with the absolute stability specifications.

Loop Shaping Design Procedure Steps

A design procedure for the closed loop shaping would go as follows:

1. Choose the bandwidth of the control system based on hardware actuation speed
2. Based on the mid-frequency disturbance attenuation requirements choose the mid-frequency gain and appropriately place one or two poles before the cross-over in order to bring the gain to 0 dB at the cross-over.
3. Check the phase margin at the cross-over; also given lower frequency desired poles and zeros (like a pole at the origin and a zero at a frequency less than a decade below the cross-over). If phase margin is not met, readjust the design, like lowering the mid-frequency gain.
4. Compute the lower zero frequency by the settling time requirements of the step response.
5. Calculate the gain of the CLG transfer function based on the mid-frequency gain at the lower frequency zero.
6. Simulate the bode plot of the CLG and the closed loop system response and make adjustments if necessary.

Note: This design procedure does not discuss margins. But normally the design will incorporate cross-over frequency margin for actuator rate uncertainty or control operation uncertainty; Margin in the phase margin for plant phase uncertainty; Mid-frequency gain margin for disturbance uncertainty; Margin in the lower frequency zero placement for response settling time; A pole placement shortly above cross-over frequency if the slope at cross-over is -20 dB/decade to prevent a possibly unmodeled plant zero at that frequency to have unforeseeable consequences on stability. The phase and gain margins would need to be rechecked for additional pole placement at this frequency range.

Lead-Lag Compensation—Controller Design Procedure for Loop Shaping

Since we designed the CLG of the feedback control system to meet the system requirements, the next step is to design the feedback controller that would give the desired CLG by also knowing the plant transfer function.

As an example let's pick a plant transfer function as

$$G_P(s) = \frac{1}{s^2 / \omega_A^2 + 2s / \omega_A + 1} \frac{2}{s^2 / \omega_P^2 + 2s / \omega_P + 1} \quad (15)$$

Let's say that the first part of the transfer function is due to the actuator with a frequency of 1000 rad/sec and the second part is due to the rest of the plant with a frequency of 70 rad/sec. A bode plot of this transfer function superimposed on the desired CLG designed is shown in Figure 20. The controller needs to be designed such that the plant together with the controller achieves the desired CLG shown in this figure. This entails that we appropriately add the controller gain, poles and zeros so that the controller transfer function together with the plant transfer function is raised in gain to match the desired CLG transfer function. Hopefully in this process the phase is matched as well.

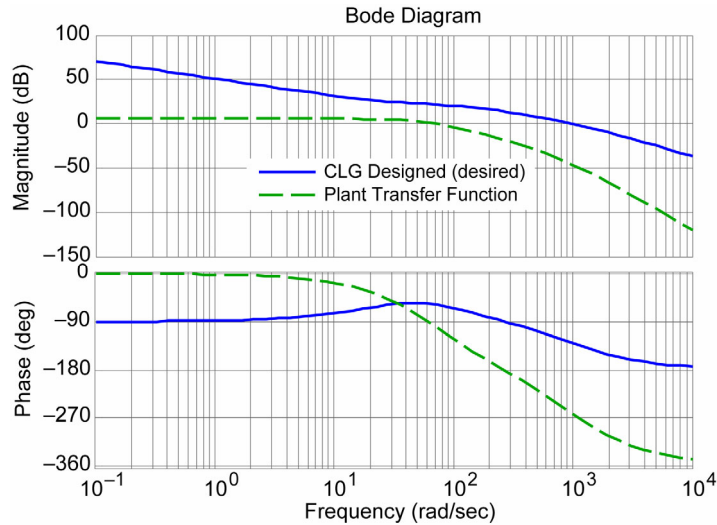

Figure 20.—Designed Closed Loop Gain and Plant Transfer Function

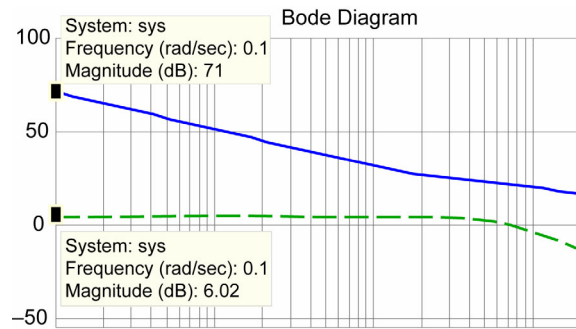

Figure 21.—Expanding Figure 20

Figure 21 shows a portion of Figure 20 expanded in the lower frequency. At 0.1 rad/sec we pick a data point. As shown the gain of the CLG at this point is 71 dB or 3548 while the plant transfer function gain is 6 dB or 2 in a linear scale. If we add a pole to the controller at the origin, then the gain of the pole at 0.1 rad/sec would be $1/0.1 = 10$ or 20 dB. Adding the gain of the plant at this frequency and subtracting the result from where we want the CLG to be $[71 - (20 + 6)] = 45$ dB or $10^{45/20} = 177.8$ for the controller gain. In another way, the gains at low frequency can be equated as follows:

$$\left[\frac{K_P K_C}{|s|} = K_{CLG} \right]_{s=j0.1} \quad (16)$$

where K_C and K_P and K_{CLG} are the plant, the controller, and the closed loop gains at low frequencies. Based on Equation (16), $K_C = 177.8$. After the DC (low frequency) control gain has been determined, the relation $|G_P(s)||G_C(s)| = |L(s)|$ can be used to calculate the transfer function $G_C(s)$ as a function of frequency.

So far we have designed the controller gain and its first pole at the origin. Now the designed CLG, based on the control design so far, matches the desired CLG at low frequency. These two CLG's will continue to match if we place the controller low frequency zero at the desired CLG low frequency zero. Thus, so far we have the controller design as

$$G_C(s) = 177.4 \frac{s/25 + 1}{s} \quad (17)$$

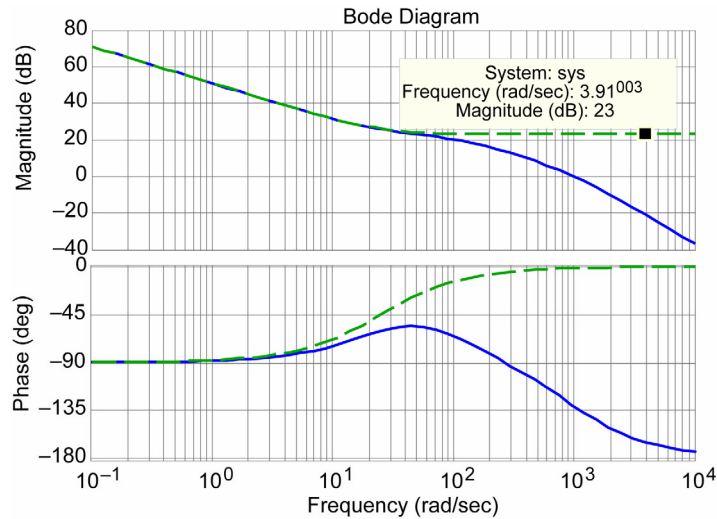

Figure 22.—Comparison of desired CLG with Controller CLG Design at this Point

The Bode plot simulation of this design including the gain of the plant (i.e., gain of 2) against the desired CLG is shown Figure 22. This figure shows that the design matches well so far at the low frequency. Next we see that the plant has a double pole with a gain of 1 at 70 rad. We would like to get rid of the effect of this double pole on the CLG because we want to maintain the gain at the mid-frequency region at the specified level of ~ 23 dB. We can do that by placing a zero just before the double pole frequency and another zero shortly after. That is a matter of practice, by forcing the poles to split one in each direction on the root locus. But also placing a double zero at the double pole location, for one thing we may not get this exactly right, but also we may need to worry about the damping of a double zero. (If a set of double poles of the plant were underdamped, then a notch filter could be used instead of the two separate zeros. To accomplish this, a double zero could be used with proper damping to filter out the peaking action of the double pole. Next we need to place a pole at 100 rad/sec to restore the desired shape of the CLG. In addition, there is a double pole at 1000 rad/sec, where in the designed CLG we originally had a single pole at that frequency. Thus, we need to place a zero at 1000 rad/sec to eliminate the effect of one of the poles. So far if we are counting, we have placed four zeros and 2 poles in the controller design. In order to make the controller design proper, we need a list two more poles in the controller design. However, we don't want these two additional poles to affect the closed loop design below the cross-over frequency. Or else, the CLG derived from the controller design and the plant will not match the desired CLG based on the specifications. Therefore, we can place the first pole at 10,000 rad/sec at the minimum, and the other pole at let's say at 15,000 rad/sec.

Based on that, the controller design will be

$$G_c(s) = 177.4 \frac{(s/25 + 1)(s/60 + 1)(s/80 + 1)(s/1000 + 1)}{s(s/100 + 1)(s/10,000 + 1)(s/15,000 + 1)} \quad (18)$$

Figure 23 shows a comparison of the desired CLG against the CLG based on the controller design. As seen, the desired and the calculated CLG's based on the controller design match very well, except slightly at the crossover where we lost some phase. The high frequency, beyond the cross-over frequency, is not as important to accurately match in this design since the control system performance is not impacted by the CLG design much beyond the cross-over frequency. In terms of magnitude, it's important for the gain to keep rolling-off after the crossover (preferably by 40 dB) in order to avoid the possibility of any unmodeled plant zeros near the cross-over from causing stability problems. In this design the phase margin is a little less than 45°, called by the spec, and the gain margin is about 15 dB. Had we designed

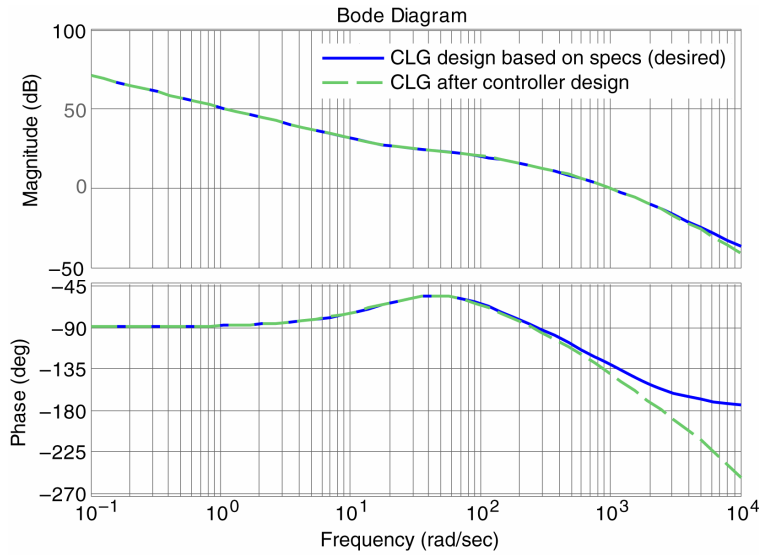

Figure 23.—Comparison of Desired CLG versus CLG based on the controller Design

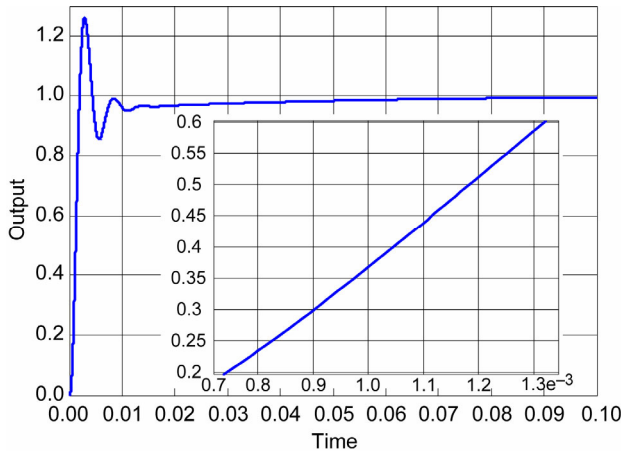

Figure 24.—Designed closed Loop Step Response

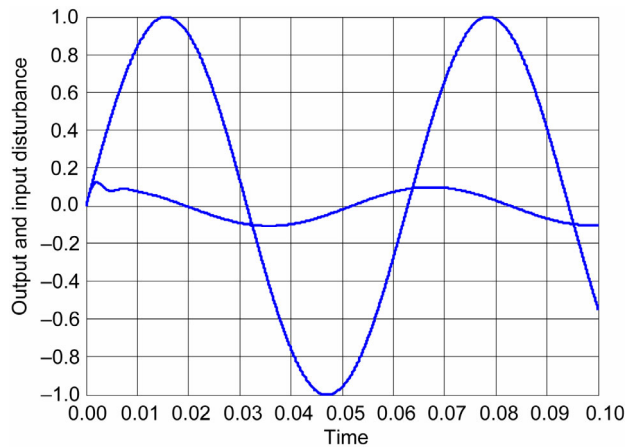

Figure 25.—Output (0.1 peak) Due to a Disturbance (1 peak) at 100 rad/sec

some margin in the beginning, it would have helped, but again the way the specs were written, the control design was expected to be borderline. Again, this was done purposely to show the limitations in the control design.

A step response of this design is shown in Figure 24, which shows a little more overshoot compared to Figure 17 as predicted with the slightly reduced phase margin of the design. The system rate (actuation rate) is approximately 750 units/sec. Figure 25 shows disturbance attenuation of this closed loop system design for a disturbance of 1 peak amplitude at 100 rad, with 10 times or 20 dB disturbance attenuation, which matches that of the CLG design.

Some adjustments can be made to boost the phase margin a little and still meet the design specifications, but at the expense of increased actuation rate. This can be done by shifting the pole at 100 up in frequency, or/and shifting the zero at 1000 lower in frequency. However, doing that in an add hoc way, without systematically rethinking and strategizing a revised design could be problematic. For instance, shifting the zero to the left in frequency will boost the phase. But this will cause the slope of the CLG to fall to zero right before the cross-over, which can cause stability problems if the phase of the plant is slightly different than what we anticipated at this frequency range. Instead, we can move the

controller pole from 100 to let's say 115 rad, which by itself will move the cross-over frequency slightly up, extend a little the mid-frequency disturbance attenuation range which will give us slightly more phase margin at the cross-over. And instead of moving the 1000 rad zero to the left in frequency, we will add another zero at somewhat higher than 1000 rad (let's say at 1300 rad) in order to get an additional boost in phase before the cross over. Adding another zero in the design necessitates an additional pole to keep the controller TF proper. Since we would like the CLG to transition, preferably with a -40 dB/decade slope shortly before (or at least shortly after the cross-over), we can place this pole at 5,000 rad. Had we placed this pole near the zero at 1300 rad, this will cancel out the phase boost we get from the zero and will do us no good in terms of the phase margin.

Making these adjustments in the controller design the new controller transfer function is

$$G_c(s) = 177.8 \frac{(s/25 + 1)(s/60 + 1)(s/80 + 1)(s/1000 + 1)(s/1300 + 1)}{s(s/115 + 1)(s/5000 + 1)(s/10000 + 1)(s/15000 + 1)} \quad (19)$$

The feedback control system diagram is shown in Figure 26.

Figure 27 shows the CLG of this control system design. As it can be seen in this figure compared to the previous design in Figure 23 the system bandwidth has been extended, the mid-frequency disturbance rejection range has been extended slightly as well, and the phase margin has been improved to about 60° . The gain margin still remains at about 15 dB. The improvement in the phase margin can be seen in the system step response in Figure 28 compared to Figure 24, at the expense of the actuation system rate which is now about 1000 units/sec. If the mid-frequency attenuation gain could be relaxed a little, both the stability margins as well as the actuation rates of the system could be comfortably designed for with adequate stability margins.

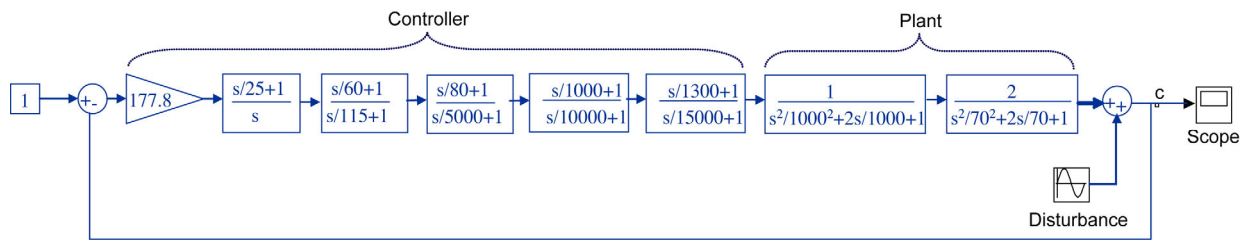

Figure 26.—Designed Controller Feedback Control System Diagram

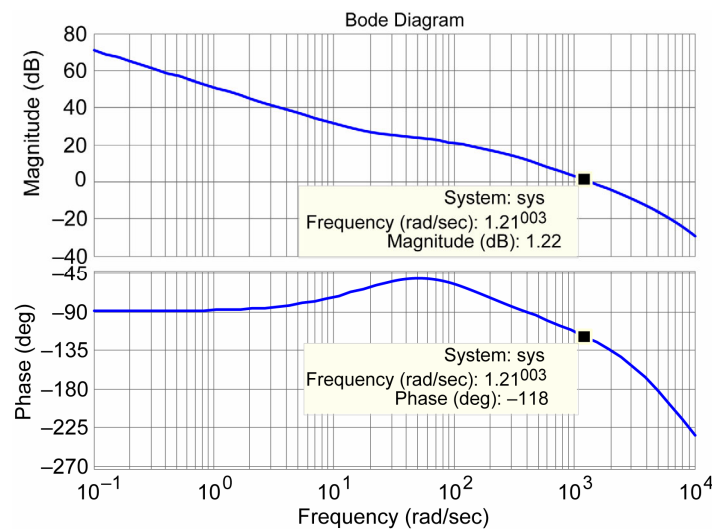

Figure 27.—CLG of Redesigned Control System

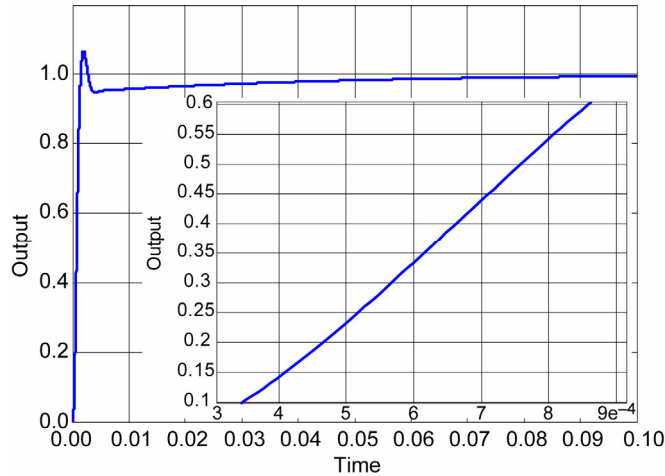

Figure 28.—Step Response of Redesigned Controller Design, Also Showing Actuation Rate

This control design and redesign example in this section demonstrates the powerful and methodical design techniques for loop shaping coupled with lead-lag compensation in linear feedback control systems, the quantitative relations between the time and frequency domain design, the limitations of control designs in terms of the specifications and the plant, and compromises that can be made to improve the design.

Comparison of Lead-Lag Control Design Versus PID

As was mentioned before, PID control is in reality a subset of lead-lag compensation. One zero and one pole at the origin is utilized in PI control and a double zero and one pole at the origin is utilized in PID. In lead-lag compensation, the objective is to compensate using zeros and poles as necessary without restricting a-priori the structure or order of the controller transfer function.

Let's say that we wanted or we were restricted to accomplish the control design in the previous section using PI or PID control. A PI controller can be expressed as

$$G_C(s) = K_P + K_I/s \quad (20)$$

where K_P and K_I are the proportional and integral gains of the controller. Summing the terms into a common denominator and extracting the control proportional gain and frequencies gives

$$G_C(s) = K_I \frac{[s/(K_I/K_P) + 1]}{s} \quad (21)$$

From Equation (21) we can see that the PI control structure has a transfer function with a proportional gain K_I , a zero at frequency K_I/K_P rad and a pole at the origin. Therefore, if we were restricted to use a PI controller, Equation (21), there is no way we can accomplish the design in Equation (19) with only one zero and one pole and satisfy the requirements. If we were to use a PID control structure as

$$G_C(s) = K_P + K_I/s + K_D s \quad (22)$$

where K_D is the derivative gain. Manipulating Equation (22) similarly to Equation (20), gives

$$G_C(s) = K_I \frac{[s^2/(K_I/K_D) + K_P s/K_I + 1]}{s} \quad (23)$$

From Equation (23), the gain of the PID controller is K_I , with a double zero at frequency $\sqrt{K_I/K_D}$ rad/sec with damping $\zeta = (1/2)(K_P/(\sqrt{K_I K_D}))$ and a pole at the origin. Again, restricting the control design to PID, with two zeros and one pole, will not permit us to satisfy the requirements. Let alone that the PID controller transfer function is not *proper* or the control action would not be *causal*.

It is obvious comparing Equations (21) and (23) that using PID control instead of PI gives us a better chance of matching the desirable CLG in Equation (14), because the PID allows the use of one more zero. The fact that PID control is not *causal* can be overcome by the structure of the plant, which allows the system as a whole to be causal.

Since we've learned from the previous sections how to best compensate and arrive at a desirable CLG that has been derived based on requirements, let's utilize PID and attempt to maximize its effectiveness in this design example. The first and most important decision is at what frequency to place the double zero of the PID. First, let's examine what happens if we placed the double zero much above the first double pole frequency of the plant, at 70 rad. If we do that, then with the pole at the origin and the double pole at 70, the CLG will be decreasing with a rate of 60 dB/decade (18 dB/octave) above 70 rad and below the double zero frequency. If the gain of the CLG at 70 rad was let's say 20 dB, that means that about one octave above the 70 rad, at slightly above 140 rad, the CLG will be crossing the 0 dB axis. For one thing, this would substantially reduce the system bandwidth and disturbance attenuation at the mid-frequency range, but also the phase of the CLG at cross-over, from the phase contribution of the poles at the origin and at 70 rad, will be depleted and the system would be unstable.

Instead, if we were to place the zeros much below the 70 rad frequency, then the gain of the CLG will be increasing at a rate of 20 dB/decade above the double zero frequency and decreasing at a rate of 20 dB/decade above the double pole frequency. Of course, we can't be asking the gain of the CLG to be much above 20 dB at 70 rad, or the cross-over will be approaching or exceed 1000 rad. Also, at this frequency range, again, all the phase margin will be depleted due to the double pole phase contribution of the plant at 1000 rad. So if the double zero is placed much below 70 rad, we will have a situation where at this low frequency the gain of the CLG reaches a minimum and the system will not have good disturbance attenuation in that frequency range. Therefore, the best design is realized when the double zero is placed near or at the plant double pole, at 70 rad.

So let's place the double zero at the double pole frequency, at 70 rad, with a 20 dB gain at this frequency. We could go with 23 dB instead, but it seems that we would be increasing the frequency of the cross-over and we will be running out of phase margin as mentioned before. Therefore, using Equation (16), $K_C = (K_{CLG} / K_P) |s|_{s=j70}$ which gives $K_C = 350$. In order not to significantly vary the CLG at this frequency we can choose the damping of the double zero to be the same as the damping of the double pole ($\zeta = 1$) at 70 rad. Plugging these values in Equation (23) for the controller gain, the frequency and the damping, the PID controller gains can be calculated ($K_P = 10$, $K_I = 350$, $K_D = 0.0714$). Now we can simulate the CLG to examine the design. The CLG of this design is shown in Figure 29. From this design it can be seen that the phase margin is only about 30°, with reduced bandwidth (~600 rad) and reduced mid-frequency disturbance attenuation.

To be fair in terms of comparing the PID and the previous lead-lag compensation designs, we would need to make the phase margin of the PID design to be approximately 60°. To accomplish this we need to reduce the controller gain and leave the zeros at 70 rad, which we've determined that the PID design would be more effective for this plant. Modifying the design accordingly, by reducing the controller gain ($K_I = 140$), the new CLG resulting from the controller redesign is shown in Figure 30. The new PID controller gains can be computed as before, $K_P = 4$, $K_I = 140$, $K_D = 0.0286$. In this PID design the phase margin is the same as the controller design based on lead-lag compensation, but we can only go as high as about 300 rad bandwidth (instead of about 1200 rad). As a result the mid-frequency disturbance attenuation has been considerably reduced as seen in Figure 30.

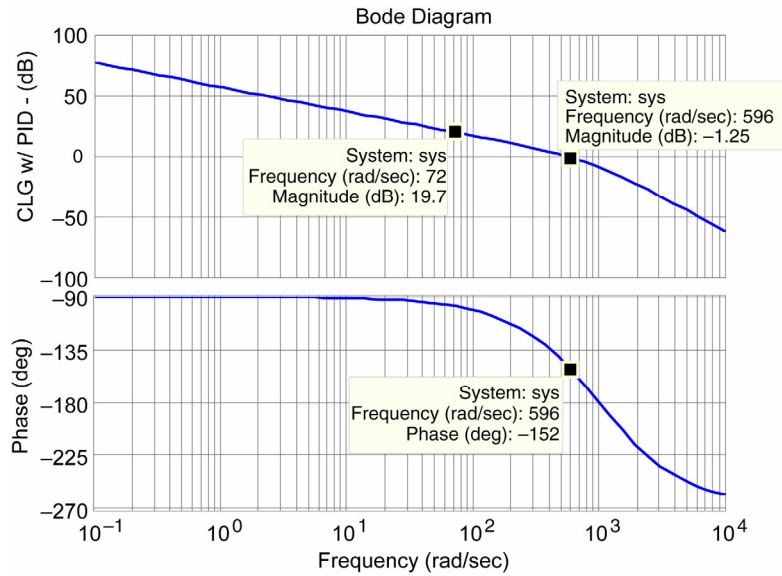

Figure 29.—CLG With PID Design (~30° phase margin)

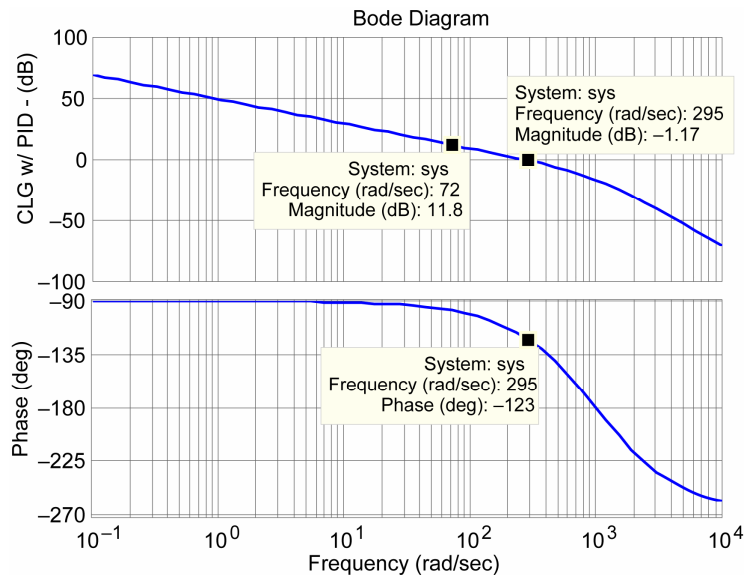

Figure 30.—CLG with PID Design (~60° phase margin)

Therefore, if we restrict ourselves to a PID design, we would not be able to meet the disturbance attenuation requirement and still maintain a reasonable phase margin. Had the first plant double pole been at a lower frequency, we would be forced to accept even lower mid-frequency disturbance attenuation with a PID design. A step response of this PID design is shown in Figure 31. Granted, the response in Figure 31 looks good compared to the response of the control design in Figure 28, but there is more to a controller design than just the time response.

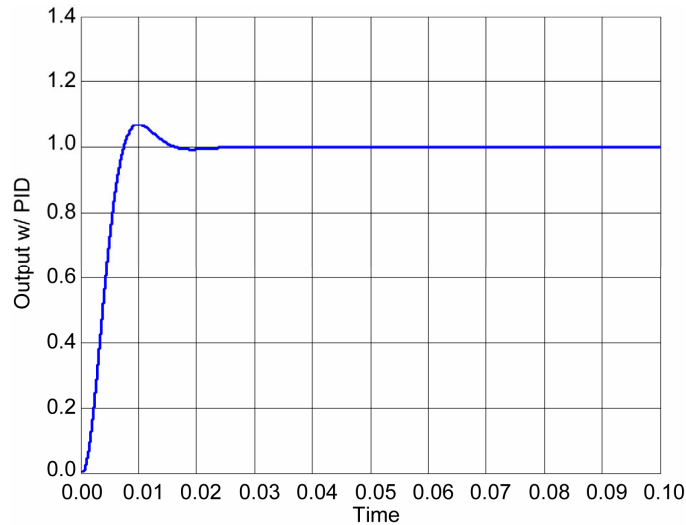

Figure 31.—Step Response of PID Design of 60° Phase Margin

Continuous Versus Discrete Domain Control Design

A large body of work is published describing discrete control design, and this paper will not attempt to expand in this area. Rather some guidelines will be given here how to turn the continuous domain design described in this paper into a discrete design for real time control applications. If the sampling time of the control processor is about ten times faster than the highest frequency in the control loop (i.e., the frequency of the highest pole or zero), the controller can be discretized (i.e., converted to difference equations) without significantly compromising the control design, especially the stability margins of the system. For instance, if the highest frequency time constant is only 1/7th the sampling time, the design could still be fine, especially if the highest frequency pole or zero doesn't significantly contribute to the phase of the CLG at the cross-over frequency. However, it is always prudent to check the discrete simulation. The conversion from continuous to discrete domain would have the most significant impact on the phase margin. If there is significant compromise of the phase margin, this will show up as an increase in the overshoot of the time response, compared to the overshoot of the continuous response. The comparison of these overshoots can be used to estimate any compromise in the phase margin. If it turns out that these guidelines are not met and the phase margin is significantly compromised, the answer is to take the existing continuous control design and shift it down in frequency; estimate a new cross-over frequency and come up with a new CLG design that maintains as much as possible stability margins and disturbance rejection, but at lower frequencies.

When the design needs to be compromised because of limitations in the updating time of the real time processor, then the time constant becomes the limiting factor of the control bandwidth, and not the actuator speed. If the updating time is known ahead of time, then it can be estimated which of the two is limiting the control bandwidth, and the proper cross-over frequency can be estimated in the beginning of the control design process.

Conclusion

This paper demonstrated a methodical linear feedback control design process, namely loop shaping with lead-lag compensation control design. This design process takes into account all the pertinent control system design requirements, whether such requirements are explicitly stated or become implicit in the design. In this design approach both the time domain response and the frequency domain are taken into account. The design methodology starts with shaping the loop gain of the closed loop system to meet the

control design requirements, and then given the plant transfer function, design the controller to match the desired closed loop gain. This loop shaping control design which also employs lead-lag compensation, is contrasted with examples and compared with traditional proportional integral derivative control design, which shows the superiority of the approach. This loop shaping methodology takes into account the plant design, more specifically the actuator speeds. Utilizing this approach can become even more beneficial in linear system control designs where disturbance attenuation is an important driver in the control design process, as is the case with aerospace type control systems.

Appendix I

This appendix lists the code for the script that produces the Nyquist plot design in the section that covers the Loop Shaping Design Example.

```
num3=353.13*[1/25 1];
den31=[1/100 1 0];
den32=[1/1000 1];
den3=conv(den31,den32);
nyquist(num3,den3) %plot the Nyquist

% plot the circle of 0.5 radius
I=1;
xx=-0.5;
while xx <= 0.5
    x2(I) = xx;
    y2(I) = x2(I)^2;
    xx = xx +0.001;
    I=I+1;
end
x2(1001)=0.5;
y2=sqrt(0.25-y2); % circle y=sqrt((0.5)^2-x^2)
y2(1001)=0;
hold on;plot(x2,y2,'r')
hold on;plot(x2,-y2,'r')

% +/- 60 degree lines from negative real axis
x=-1:0.1:0;
y=1.732*x; %equation of straight line of 60 degree angle
hold on; plot(x,y,'r')
hold on; plot(x,-y,'r')
y=1.0*x; %equation of straight line of 45 degree angle
hold on; plot(x,y,'g--')
hold on; plot(x,-y,'g--')
```

References

1. Smith S.C.; Messner W.; “Loop Shaping with Closed-Loop Magnitude Contours on the Bode Plot” Proceeding of the American Control Conference, Anchorage, AK, May 8-12, 2002.
2. Balley F.N.; Hul C.H.; “CACSD Tools for Loop Gain-Phase Shaping Design of SISO Robust Controllers,” IEEE Controls Journal, 1989.
3. McFarlane D.; Glover K.; “An H_∞ Design Procedure Using Robust Stabilization of Normalized Coprime Factors, Loop Shaping Design Procedure Using Synthesis,” IEEE Proceedings of the 27th Conference on Decision and Control, Austin, TX, 1998.
4. D’Azzo J.J.; Houpis H.C.; “Linear Control System Analysis and Design,” McGraw-Hills, Inc, 1975.

REPORT DOCUMENTATION PAGE

Form Approved
OMB No. 0704-0188

The public reporting burden for this collection of information is estimated to average 1 hour per response, including the time for reviewing instructions, searching existing data sources, gathering and maintaining the data needed, and completing and reviewing the collection of information. Send comments regarding this burden estimate or any other aspect of this collection of information, including suggestions for reducing this burden, to Department of Defense, Washington Headquarters Services, Directorate for Information Operations and Reports (0704-0188), 1215 Jefferson Davis Highway, Suite 1204, Arlington, VA 22202-4302. Respondents should be aware that notwithstanding any other provision of law, no person shall be subject to any penalty for failing to comply with a collection of information if it does not display a currently valid OMB control number.

PLEASE DO NOT RETURN YOUR FORM TO THE ABOVE ADDRESS.

1. REPORT DATE (DD-MM-YYYY) 01-09-2007		2. REPORT TYPE Technical Memorandum		3. DATES COVERED (From - To)	
4. TITLE AND SUBTITLE Feedback Control Systems Loop Shaping Design With Practical Considerations				5a. CONTRACT NUMBER	
				5b. GRANT NUMBER	
				5c. PROGRAM ELEMENT NUMBER	
6. AUTHOR(S) Kopasakis, George				5d. PROJECT NUMBER	
				5e. TASK NUMBER	
				5f. WORK UNIT NUMBER WBS 984754.02.07.03.20.02	
7. PERFORMING ORGANIZATION NAME(S) AND ADDRESS(ES) National Aeronautics and Space Administration John H. Glenn Research Center at Lewis Field Cleveland, Ohio 44135-3191				8. PERFORMING ORGANIZATION REPORT NUMBER E-16201	
9. SPONSORING/MONITORING AGENCY NAME(S) AND ADDRESS(ES) National Aeronautics and Space Administration Washington, DC 20546-0001				10. SPONSORING/MONITORS ACRONYM(S) NASA	
				11. SPONSORING/MONITORING REPORT NUMBER NASA/TM-2007-215007	
12. DISTRIBUTION/AVAILABILITY STATEMENT Unclassified-Unlimited Subject Categories: 06 and 08 Available electronically at http://gltrs.grc.nasa.gov This publication is available from the NASA Center for AeroSpace Information, 301-621-0390					
13. SUPPLEMENTARY NOTES					
14. ABSTRACT This paper describes loop shaping control design in feedback control systems, primarily from a practical stand point that considers design specifications. Classical feedback control design theory, for linear systems where the plant transfer function is known, has been around for a long time. But it's still a challenge of how to translate the theory into practical and methodical design techniques that simultaneously satisfy a variety of performance requirements such as transient response, stability, and disturbance attenuation while taking into account the capabilities of the plant and its actuation system. This paper briefly addresses some relevant theory, first in layman's terms, so that it becomes easily understood and then it embarks into a practical and systematic design approach incorporating loop shaping design coupled with lead-lag control compensation design. The emphasis is in generating simple but rather powerful design techniques that will allow even designers with a layman's knowledge in controls to develop effective feedback control designs.					
15. SUBJECT TERMS Loop shaping control design; Loop shaping; Feedback control design; Control design; Disturbance rejection; Actuation rates control design					
16. SECURITY CLASSIFICATION OF:			17. LIMITATION OF ABSTRACT	18. NUMBER OF PAGES	19a. NAME OF RESPONSIBLE PERSON
a. REPORT	b. ABSTRACT	c. THIS PAGE			STI Help Desk (email:help@sti.nasa.gov)
U	U	U	UU	35	19b. TELEPHONE NUMBER (include area code) 301-621-0390

