

**CONTINUED INVESTIGATION OF LEAKAGE AND POWER LOSS TEST RESULTS
FOR COMPETING TURBINE ENGINE SEALS**

Irebert R. Delgado
U.S. Army Research Laboratory
Glenn Research Center
Cleveland, Ohio

Margaret P. Proctor
National Aeronautics and Space Administration
Glenn Research Center
Cleveland, Ohio

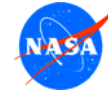

**Continued Investigation of
Leakage and Power Loss Test Results for
Competing Turbine Engine Seals**

**Irebert R. Delgado
U. S. Army Research Laboratory
NASA Glenn Research Center
Cleveland, Ohio**

**Margaret P. Proctor
NASA Glenn Research Center
Cleveland, Ohio**

Prepared 2006 NASA Seal/Secondary Air System Workshop
Ohio Aerospace Institute, Cleveland, Ohio
Nov. 14-15, 2006

The authors would like to acknowledge NASA Glenn Research Center where all the testing was conducted, Bruce Steinetz who guided the design, procurement, and fabrication of the High Temperature, High Speed Turbine Seal Test Rig, and Joseph Flowers from the Army Research Lab who provided test and engineering support.

Motivation

- **Follow-up Study**
 - “Leakage and Power Loss Test Results for Competing Turbine Engine Seals” by Proctor and Delgado, (NASA/TM – 2004-213049)
- **Benefits**
 - Higher engine performance
 - Decreased specific fuel consumption
 - Increased thrust
 - Better investment towards performance gain than components, such as compressors and turbines.
- **Heat Generation and Power Loss**
 - Changes in engine air temperatures from stage to stage can negatively affect engine efficiencies.
 - Friction from contacting seals increases the amount of torque needed.
 - Advanced engines operate at very high temperatures. Excessive heat generation at the seal could expose downstream components to temperatures that exceed material capabilities.

This study is a follow-up on a previous paper published by the authors for the 2004 ASME Turbo Expo. Experimental labyrinth and annular seal data are included in this presentation.

Approach

- Conduct literature review
- Use previous and new baseline NASA seal experimental leakage and power loss data
- Adjust data to account for disk and bearing windage
- Compare experimental data with literature

Previous brush and finger seal data are compared with new annular and labyrinth seal data. The results are also compared with literature. Finally, disk and bearing windage are accounted for and described in detail later in the presentation.

Literature Review

- 1987 – Windage effect of rim seals. (Hasser et al.)
 - Modelled wheel space cavity
 - Results agreed with full-scale engine and rig data
 - Results agreed with Daily & Nece axial spacing ratio
 - Results agreed with bolt drag effects
- 1989 – Laby. seal power dissipation. (McGreehan et al.)
 - Windage heating developed in first 2 pockets of a 5-knife labyrinth seal
 - Windage decreases with increasing swirl velocity ratio
- 1990 – Laby. seal recirculation zone. (Demko et al.)
 - Existence of a secondary recirculation zone in a labyrinth seal at high speeds
- 1996 – Laby. seal windage heating. (Millward et al.)
 - Seal power dissipation increases with increasing mass flow rate
- 2003 – Brush seal/shaft thermal effects. (Owen et al.)
 - Derived a power law relationship between mass flow rate, shaft temperature, and power dissipated

A review of the literature provided some labyrinth and brush seal data at comparable surface speeds, temperatures, and pressure ratios. This will be seen later in the presentation.

NASA Turbine Seal Rig

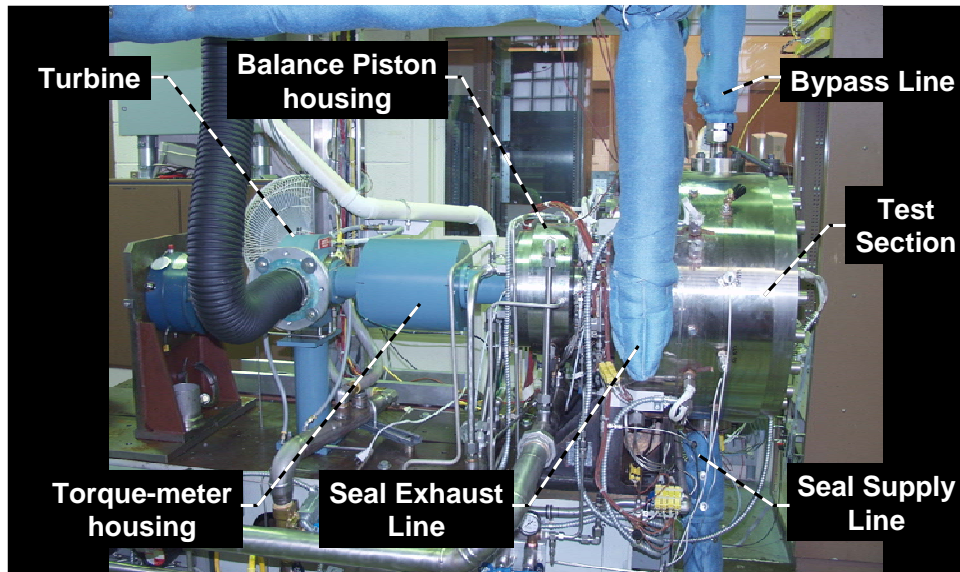

The NASA High Temperature High Speed Turbine Seal Test Rig located at NASA Glenn Research Center in Cleveland, Ohio is capable of testing current and advanced seals through 1500F, 250 psid, and >1000 ft/s.

Annular Seal



- Material: Inco 625
- Seal Dia: 216 mm
- Seal Clearance: 0.3 mm

Note, each grid square is $\frac{1}{4}$ inch

A picture of the annular seal inner diameter.

Labyrinth Seal



- Design : 4-Knife
- Material : Inco 625
- Seal Dia : 216 mm
- Seal Clr. : 0.3 mm
- Tooth height : 0.762 mm
- Pitch : 1.016 mm
- Tip width : 0.318 mm
- Tooth angle : 7.5°

This slide shows a picture of the 4-knife labyrinth seal used for baseline power loss data.

Brush Seal

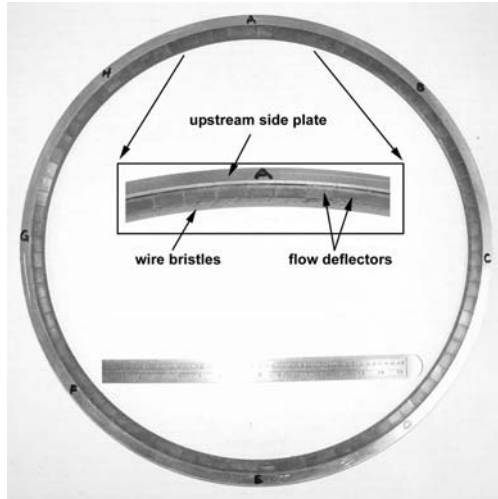

- Design w/Flow Deflector
- Material Haynes 25 Bristles
Inco 625 Sideplates
- Seal Diameter 216 mm
- Seal Clearance ~ -0.1 mm
- Bristle lay angle 50°
- Bristle dia. 102 μm
- Density 68 wires/mm
- Fence height 1.27 mm

The brush seal supplied by Eaton has a flow deflector installed on the high pressure side. Power loss data taken previously is compared with current annular and labyrinth seal power loss data.

Finger Seal

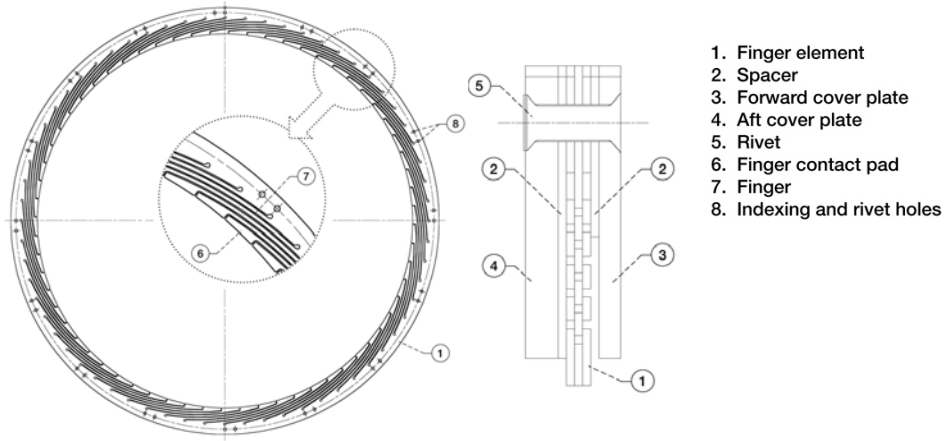

- Design Pressure-Balanced
- Seal Dia. 216 mm
- Seal Clr. -0.2 mm

The pressure-balanced finger seal was supplied by Honeywell.

Comparison of Test Seal Design Parameters

Seal Type	Material	Radial Clearance at 297K [mm]	Axial Length [mm]
Annular	Inco 625	0.3	11
4-knife labyrinth	Inco 625	0.3	11
Brush	Haynes 25 Bristles	-0.1	~1.0 bristle pack width
Finger	Haynes 25	-0.2	Similar to brush seal

This slide shows a quick glance at differences in material, radial clearance, and axial length for the four seals tested.

Seal Test Conditions

- 5 inlet air temperatures • 297 K to 922 K
297, 533, 700, 811, 922 K
(75, 500, 800, 1000, 1200°F)
- 5 pressure differentials • 69 to 517 kPa
69, 138, 276, 345, 517 kPa
(10, 20, 40, 50, 75 psid)
- 6 surface speeds • 0 to 366 m/s
0, 113, 183, 274, 283, 366 m/s
0, 371, 600, 900, 928, 1200 ft/s

Not all conditions were obtained for each seal.

Self-Explanatory

Seal Flow Factor and Power Loss

- Seal Leakage (Flow Factor, ϕ)

$$\phi = \frac{\dot{m}\sqrt{T_{avg}}}{P_u D_{seal}}, \frac{kg - \sqrt{K}}{MPa - m - s}$$

- Seal Power Loss

- Torquemeter has an absolute accuracy of 0.13%.
- Tare Torque calibration curves (temperature, speed) used.
- Frictional torque, M_o , due to test disk & balance piston included

$$M_o = C_{m,o} \rho \omega^2 a^2 / (4g) \quad C_{m,o} = 0.102 (s/a)^{1/10} / (Re^{1/5})$$

- Test end bearing windage included

$$T = f D_1 W / 2$$

- Seal Torque = (Torquemeter Torque) – (Tare Torque) – [(Test Disk Torque) + (Balance Piston Torque) + (Bearing Torque)]_{due to Δp}
- Power loss = (Seal Torque) x (Angular Velocity)

Seal flow factor and power loss were calculated as shown. In addition disk and bearing windage are accounted for in the power loss calculations.

Flow Factor vs. Speed at 700 K and 276 kPa.

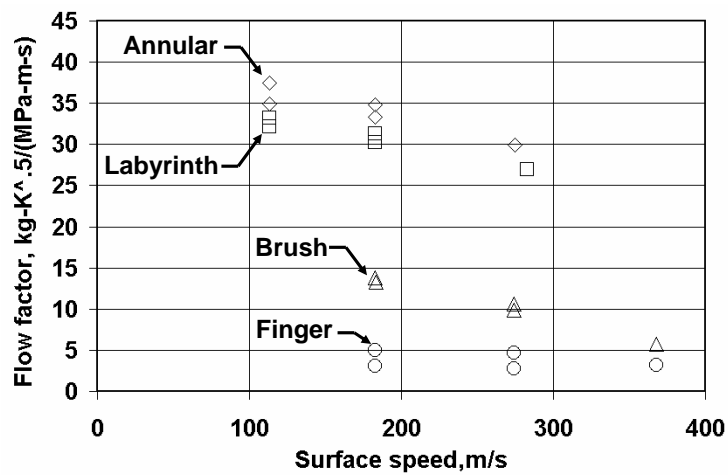

- Flow factor decreases with increasing surface speed.
- Flow factors influenced by large seal starting clearances (annular, labyrinth) as well as seal pressure closing forces (i.e. brush, finger)

Flow factor is observed to decrease with increasing surface speed. However large starting clearances and seal pressure closing forces affect flow factor as well.

Flow Factor vs. Speed at 276 kPa and 700, & 922 K.

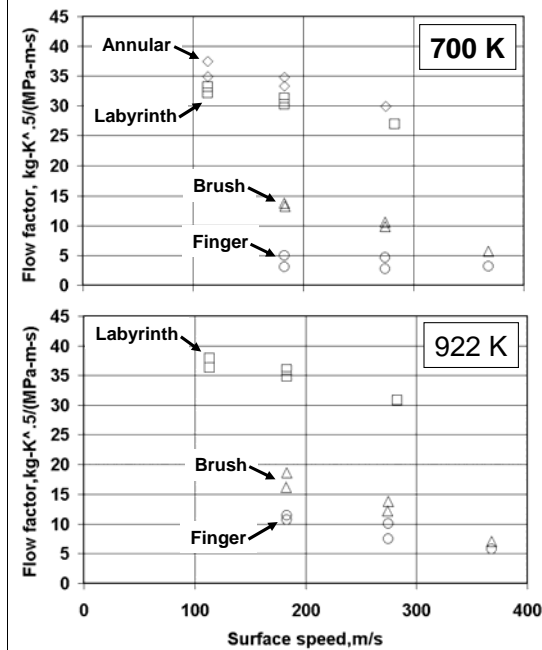

- Seals grow larger than disk due to coefficient of thermal expansion (CTE) mismatch
- Larger clearances result in larger flow rates
- Brush and finger seal leakage are 2-3 times less than annular and labyrinth seal leakage

Flow factor is observed to increase with increasing temperature. This is largely a result of CTE mismatch between the disk and seal. However brush and finger seals show 2-3 times less leakage than annular or labyrinth seals.

Seal Power Loss vs. Speed at 297 K and 276 kPa.

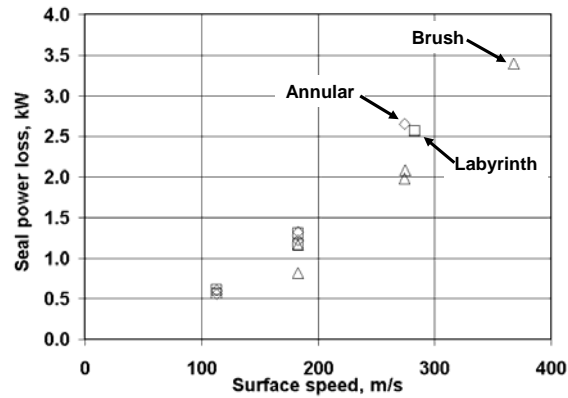

- Seal power loss increases with increasing surface speed
- Labyrinth seal data from Millward and Edwards is 2 to 3x higher (4 – 8 kW) at ambient temperature, 276 kPa, & 282 m/s

• Labyrinth Seal Design Differences

	<u>NASA</u>	<u>Millward</u>
Teeth	4	5
Radial CL	0.3 mm	1.12 mm
Pin/Pout	3.5	1.5
Axial Width	X	2X
Rotation?	No	Yes

Seal power loss is observed to increase with increasing surface speed. Labyrinth seal power loss data from Millward and Edwards are 2-3 times greater than the NASA labyrinth seal data. Differences in labyrinth seal design may explain the discrepancy.

Seal Power Loss vs. Speed at 700 K and 276 kPa.

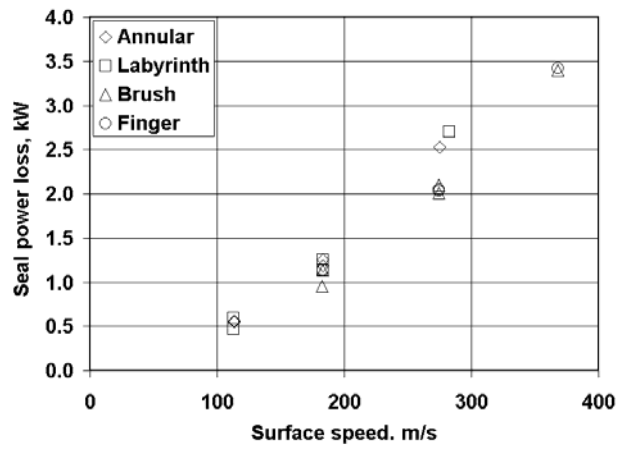

- For each seal, power loss varied by $\pm 5\%$ at most with increasing temperature.
- Annular and labyrinth seal power loss were consistently higher than brush or finger seal power loss at each test temperature.

Seal power loss was found to vary only 5% with increasing temperature.

Seal Power Loss vs. Speed at 68.9 and 276 kPa at 700 K.

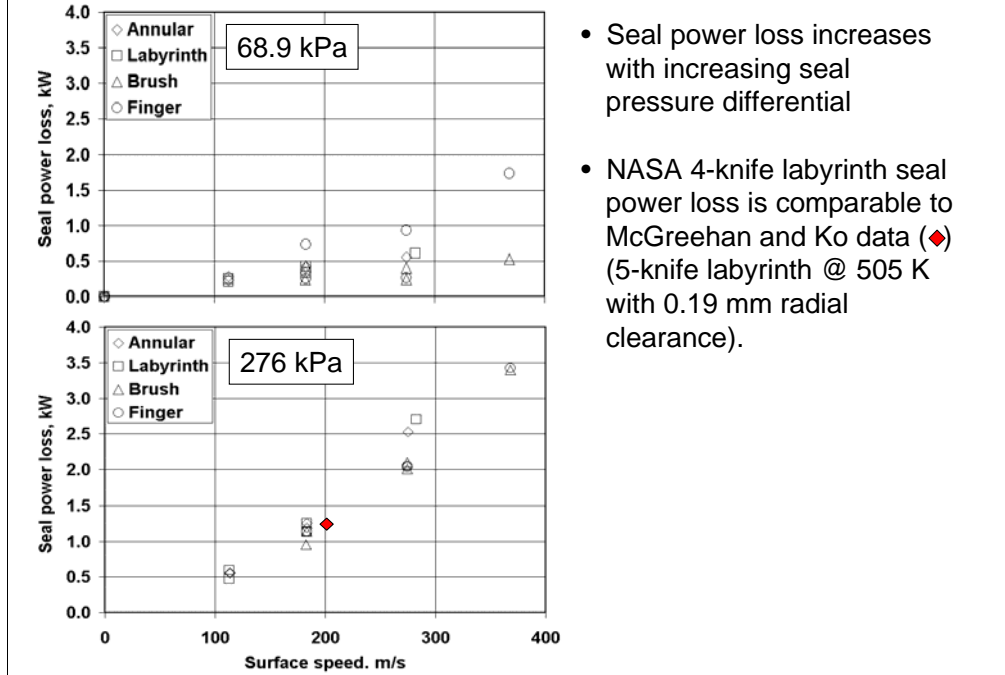

- Seal power loss increases with increasing seal pressure differential
- NASA 4-knife labyrinth seal power loss is comparable to McGreehan and Ko data (♦) (5-knife labyrinth @ 505 K with 0.19 mm radial clearance).

Seal power loss is observed to increase with increasing seal pressure differential. 5 knife labyrinth seal data from McGreehan and Ko are similar.

Seal Power Loss vs. Speed at 297 K and 276 kPa.

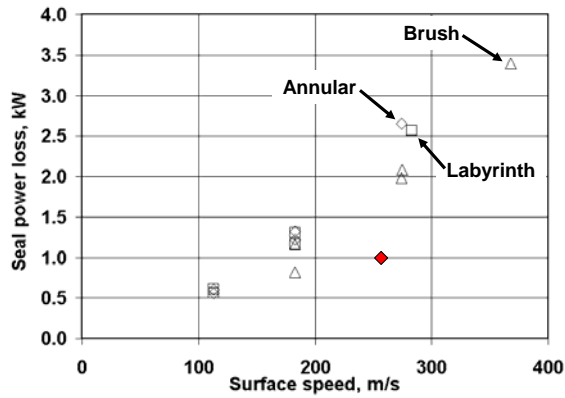

- NASA brush seal power loss is 2x that reported by Millward and Edwards (♦) at ambient temperature, 276 kPa, and 264 m/s

- Brush Seal Design Differences

	<u>NASA</u>	<u>Millward</u>
Radial CL	-0.1 mm	0 mm
Pin/Pout	3.4	1.3
Seal Dia.	216 mm	388 mm

- NASA brush seal flow rate (0.03 kg/s) is lower than Millward data (0.1 kg/s)
- Mass flow rate is proportional to seal diameter.

Differences in brush seal design may explain the discrepancy between the NASA data and that reported by Millward and Edwards. However, mass flow rate is found to be proportional to seal diameter.

Seal power loss vs. mass flow rate at 922 K and 183 m/s.

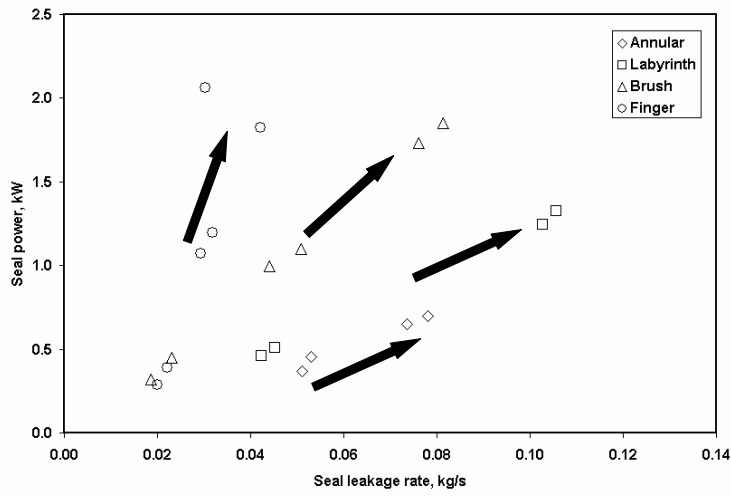

Seal power loss increases with mass flow rate.

Seal power loss is observed to increase with increasing mass flow rate.

Conclusions - Seal Leakage

- Seal leakage decreases with increasing surface speed due to reduced clearances from disk centrifugal growth.
- Annular and labyrinth seal leakage are 2-3 times greater than brush and finger seal leakage.
- Seal leakage rates increase with increasing temperature because of seal clearance growth due to different coefficients of thermal expansion between the seal and test disk.

Self-Explanatory

Conclusions - Seal Power Loss

- Seal power loss is not strongly affected by inlet temperature.
- Seal power loss increases with increasing surface speed, seal pressure differential, mass flow rate or flow factor, and radial clearance.
- The brush and finger seals had nearly the same power loss.
- Annular and labyrinth seal power loss were higher than finger or brush seal power loss. The brush seal power loss was the lowest and 15-30% lower than annular and labyrinth seal power loss.

Self-Explanatory

Future Work Needed

- Combined experimental/analytical effort
 - Compare CFD analyses with baseline seal experiments that obtain internal seal temperature and pressure measurements
- Test the effect of seal axial thickness
 - Brush & finger seals had lower power losses than annular and labyrinth seals possibly due to shorter axial lengths
 - Test a two-knife labyrinth with a shorter axial length
- Test the effect of preswirl on seal power loss
 - McGreehan and Ko found that preswirl in the direction of rotation reduces power loss

Self-Explanatory