



US005628517A

United States Patent [19]

[11] Patent Number: **5,628,517**

Jia

[45] Date of Patent: **May 13, 1997**

[54] **CONTRACTING/EXPANDING SELF-SEALING CRYOGENIC TUBE SEALS**

[75] Inventor: **Lin X. Jia**, Upton, N.Y.

[73] Assignee: **Florida Atlantic University**, Boca Raton, Fla.

[21] Appl. No.: **71,418**

[22] Filed: **Jun. 1, 1993**

[51] Int. Cl.⁶ **F16J 15/08**

[52] U.S. Cl. **277/26; 277/170; 277/207 A; 277/236; 285/917**

[58] Field of Search **277/26, 27, 170, 277/207 A, 236; 285/41, 187, 917, 918, 369**

[56] **References Cited**

U.S. PATENT DOCUMENTS

2,766,829	10/1956	Watts et al.	285/140 X
3,056,615	10/1962	Breitenstein	285/187
3,093,398	6/1963	Fawcett et al.	285/187 X
3,210,098	10/1965	Watts	285/187 X
3,301,577	1/1967	Latham	285/187
3,411,812	11/1968	Prince et al.	285/187

3,632,143	1/1972	Lessmann	285/187
3,775,989	12/1973	Mursinna et al.	62/55
3,929,358	12/1975	Eckhardt	285/353
4,072,245	2/1978	Sloan, Jr.	277/206 R
4,349,203	9/1982	Schülke	285/187
4,491,347	1/1985	Gustafson	285/47
4,659,116	4/1987	Cameron	285/27
4,813,342	3/1989	Schneider et al.	277/26
4,854,597	8/1989	Leigh	277/207 A
4,865,331	9/1989	Porter	277/26
5,083,821	1/1992	Friend	285/355
5,355,908	10/1994	Berger et al.	285/917

Primary Examiner—William A. Cuchlinski, Jr.

Assistant Examiner—John L. Beres

Attorney, Agent, or Firm—Saliwanchik, Lloyd & Saliwanchik

[57] **ABSTRACT**

Contracting/expanding self-sealing cryogenic tube seals are disclosed which use the different properties of thermal contraction and expansion of selected dissimilar materials in accord with certain design criteria to yield self-tightening seals via sloped-surface sealing. The seals of the subject invention are reusable, simple to assemble, and adaptable to a wide variety of cryogenic applications.

15 Claims, 12 Drawing Sheets

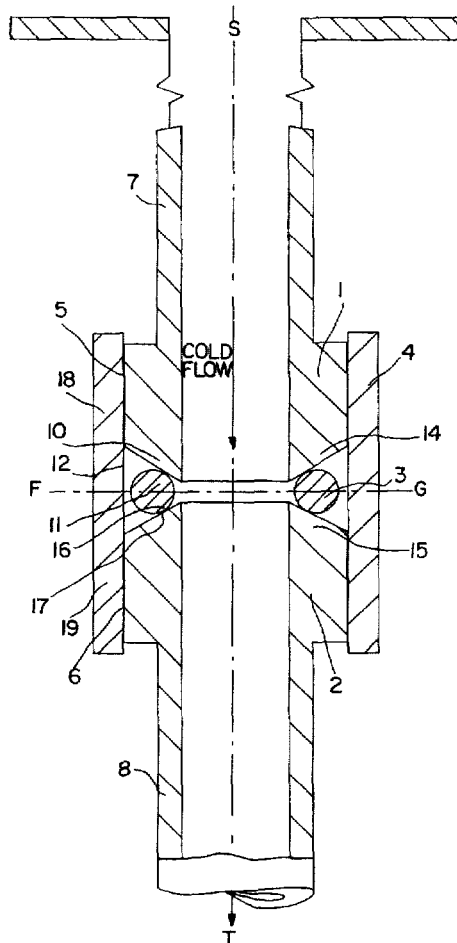

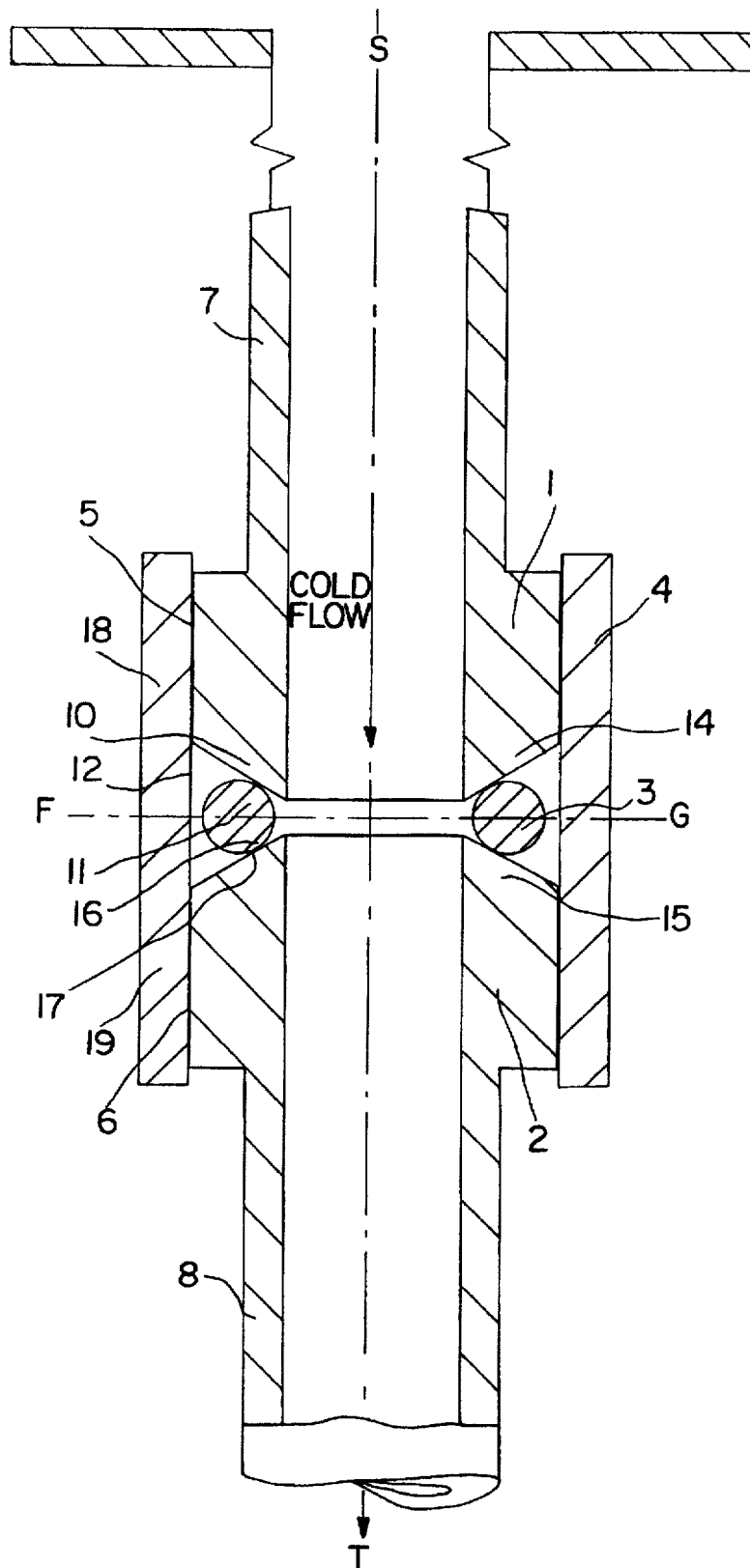

FIG. 1

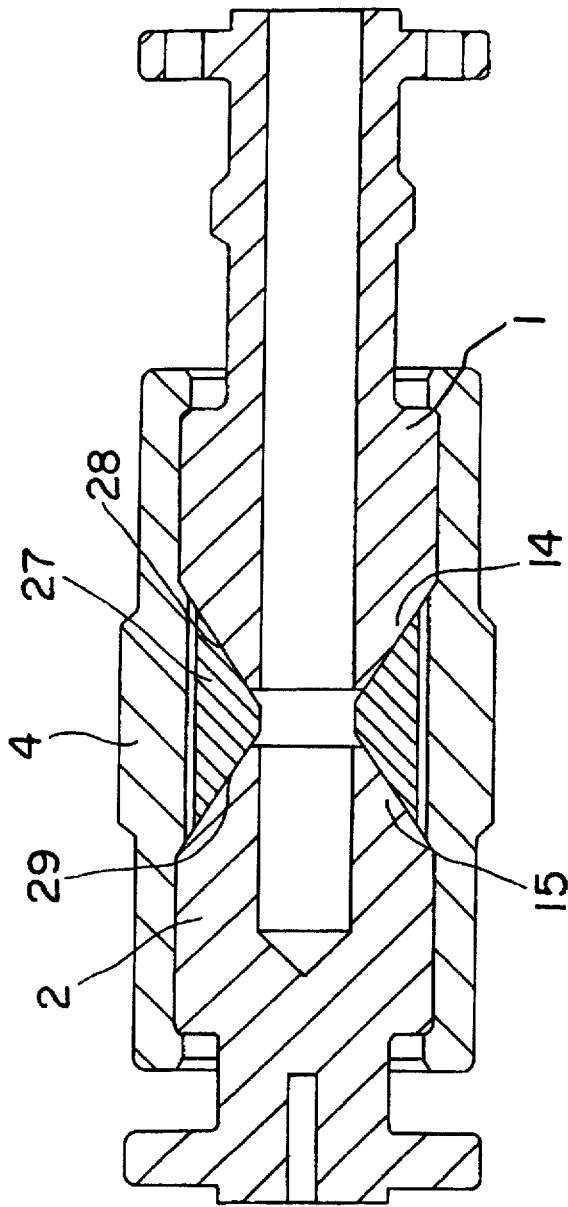

FIG. 2B

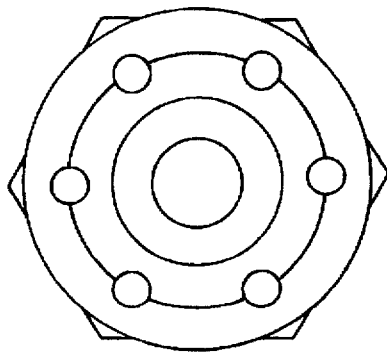

FIG. 2A

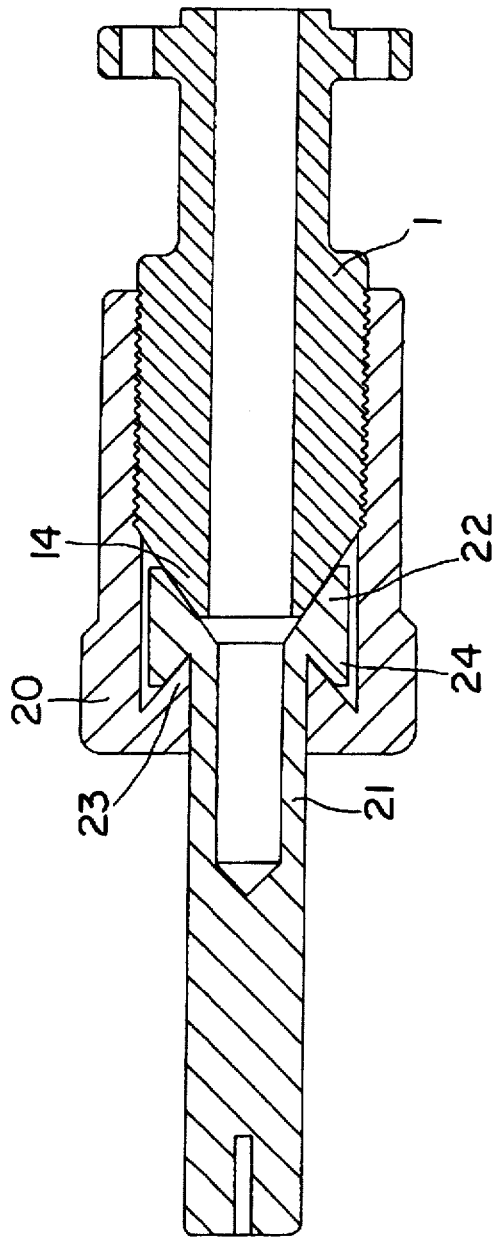

FIG. 3B

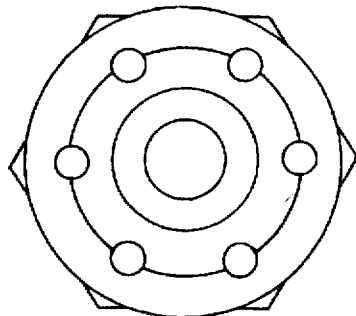

FIG. 3A

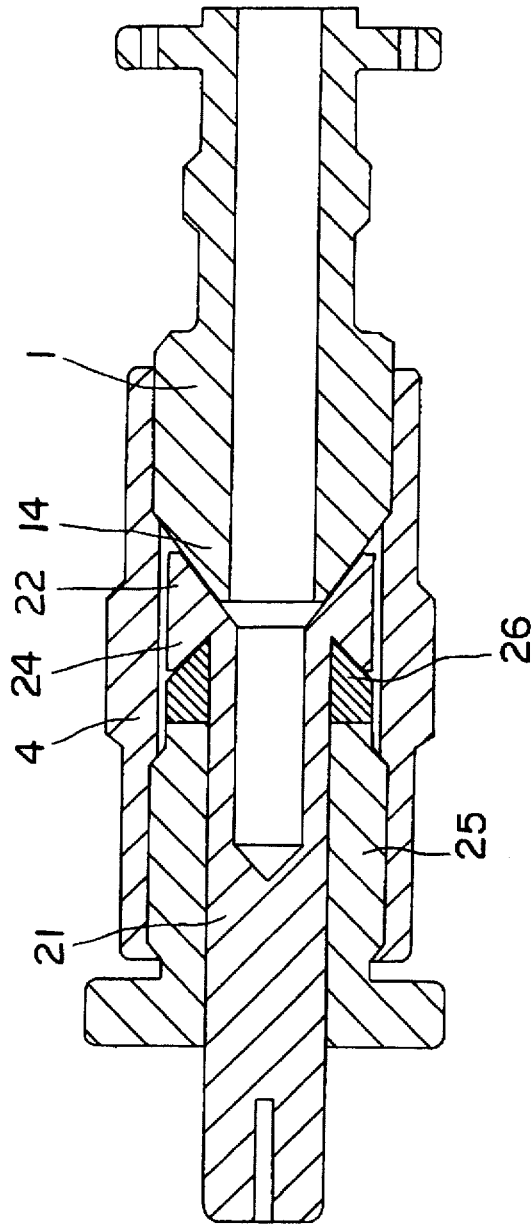

FIG.4B

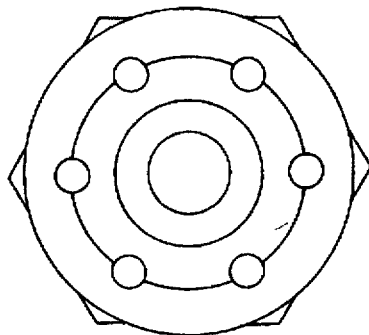

FIG.4A

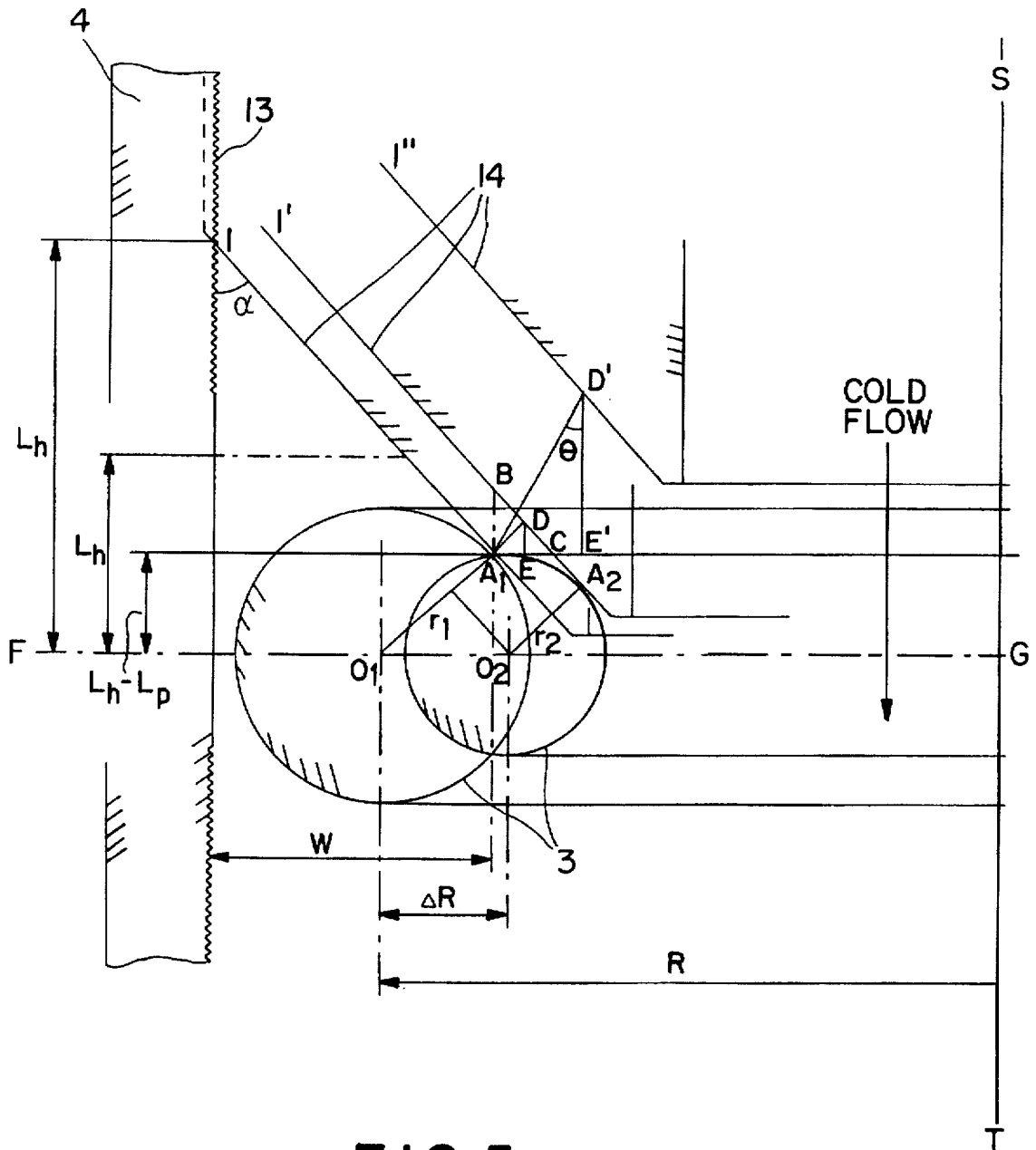

FIG. 5

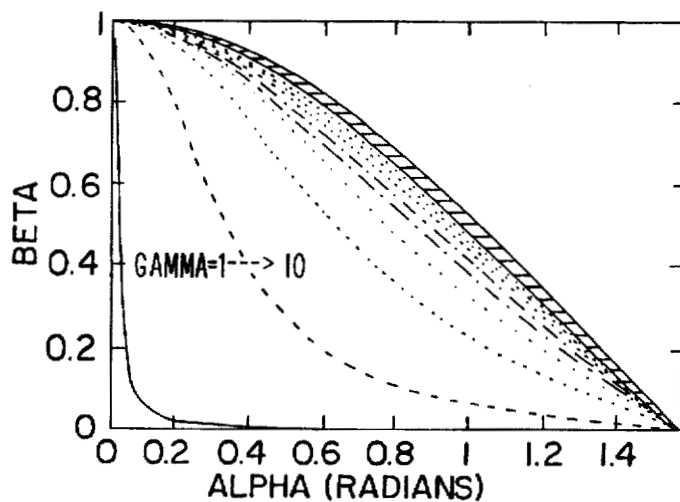

FIG.6A

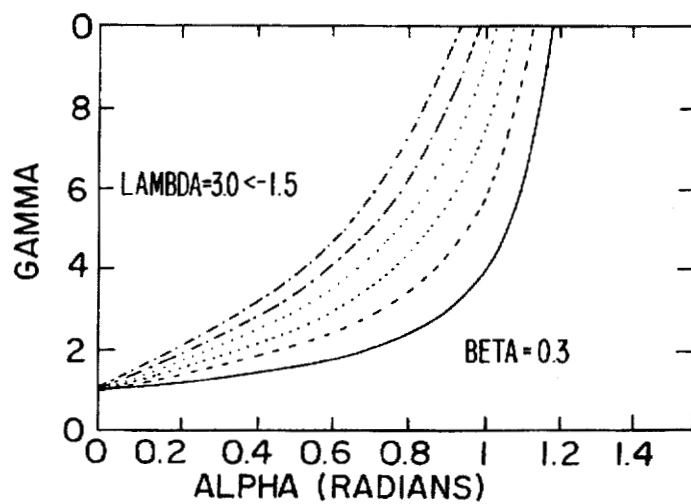

FIG.6B

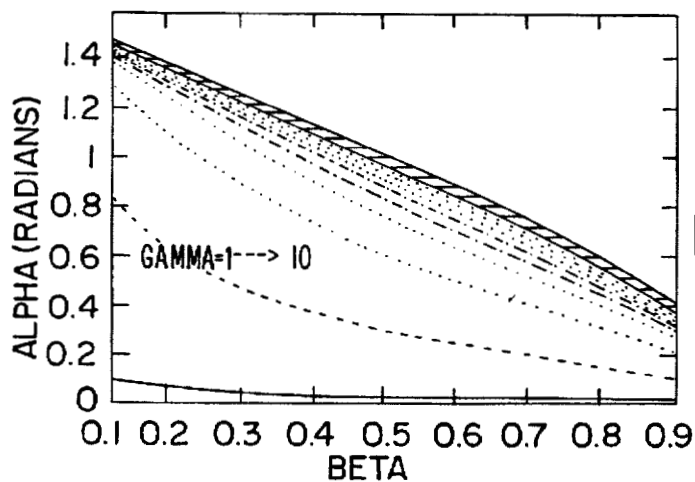

FIG.6C

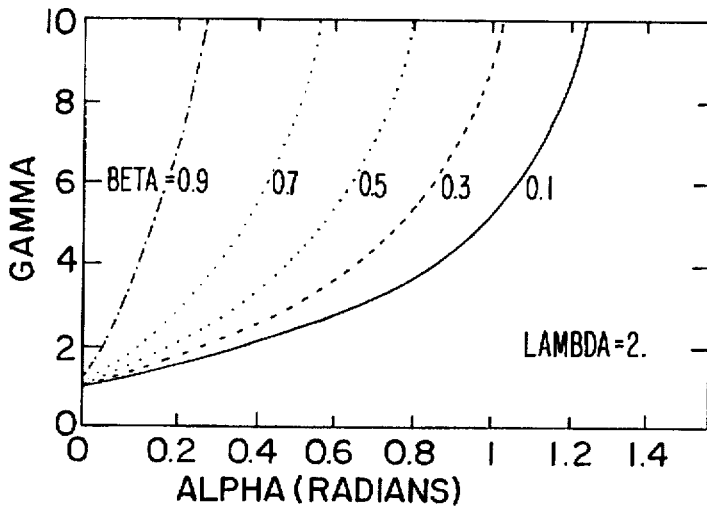

FIG.6D

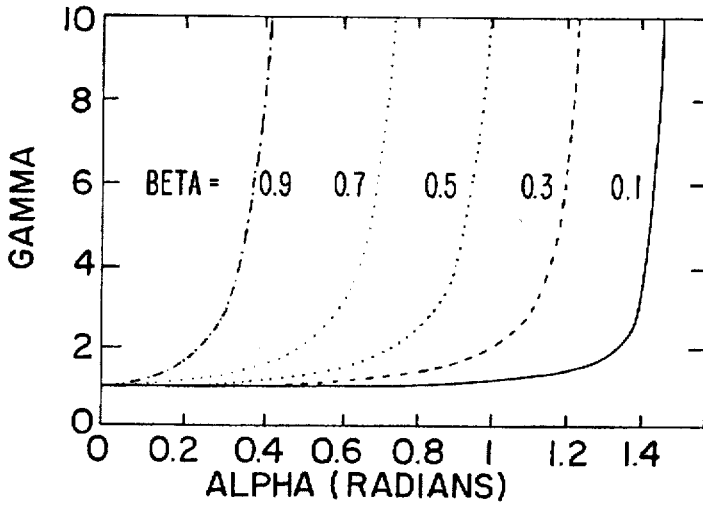

FIG.6E

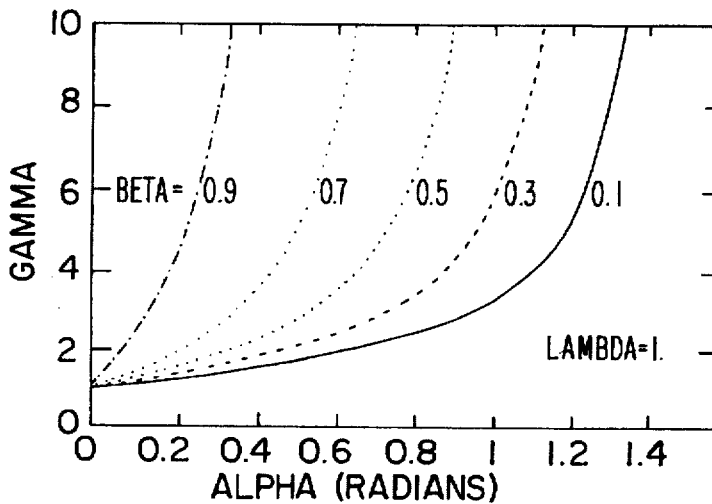

FIG.6F

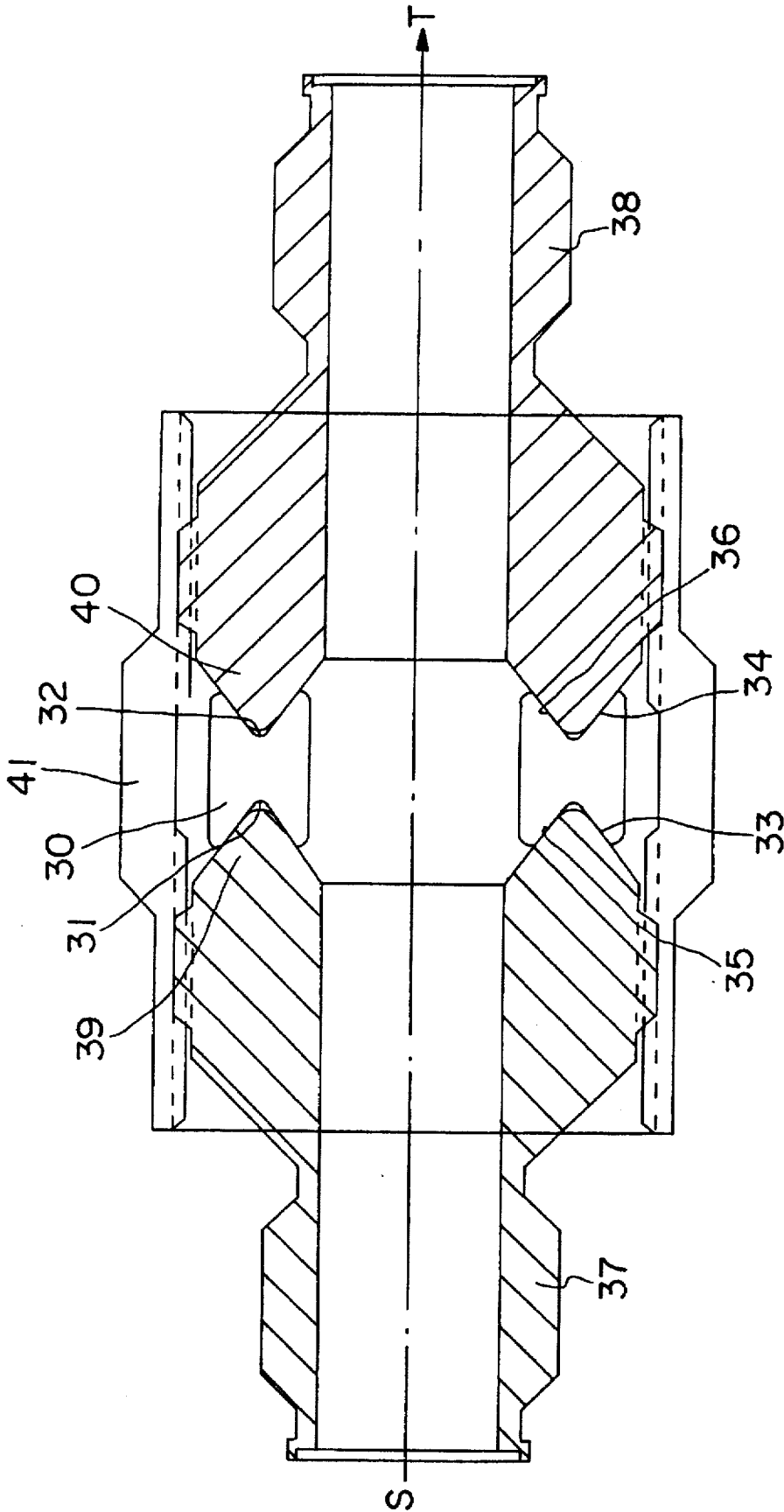

FIG. 7

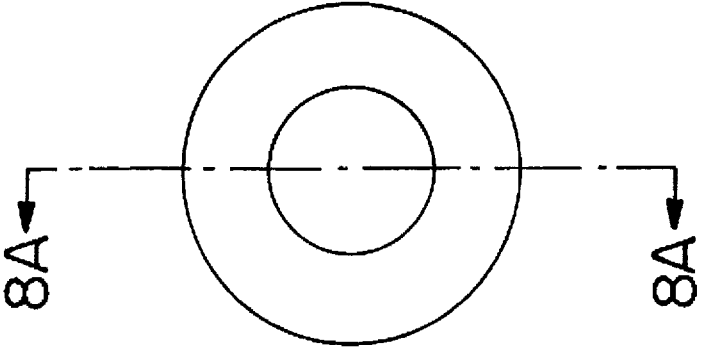

FIG. 8B



FIG. 8A

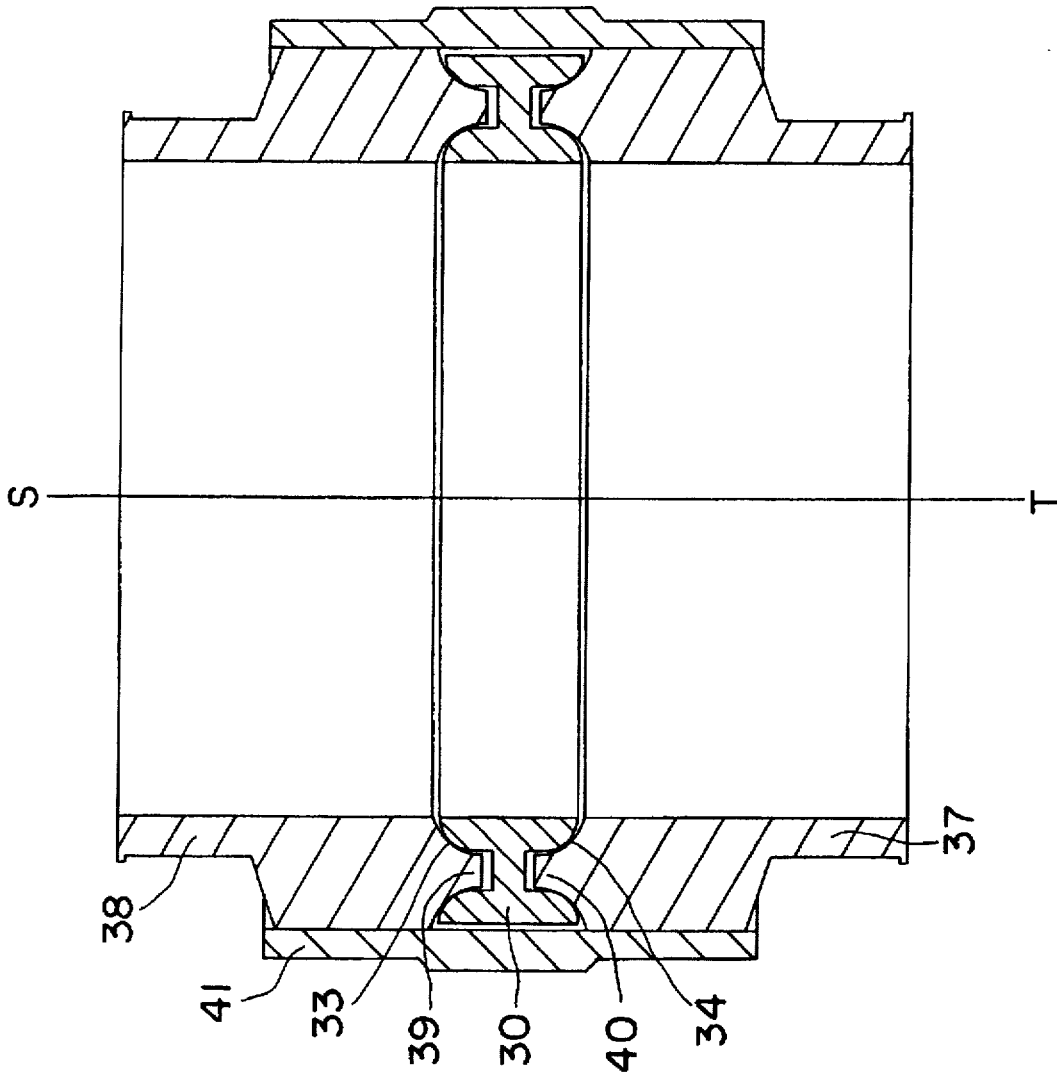

FIG. 9

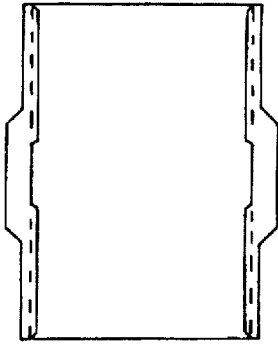

FIG. 11A

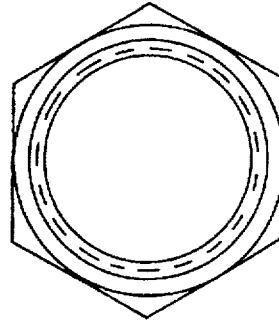

FIG. 11B

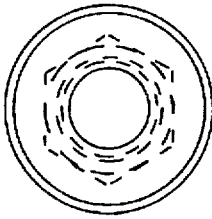

FIG. 10B

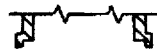

FIG. 10D

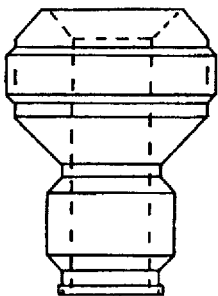

FIG. 10A

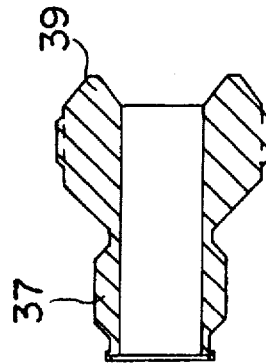

FIG. 10C

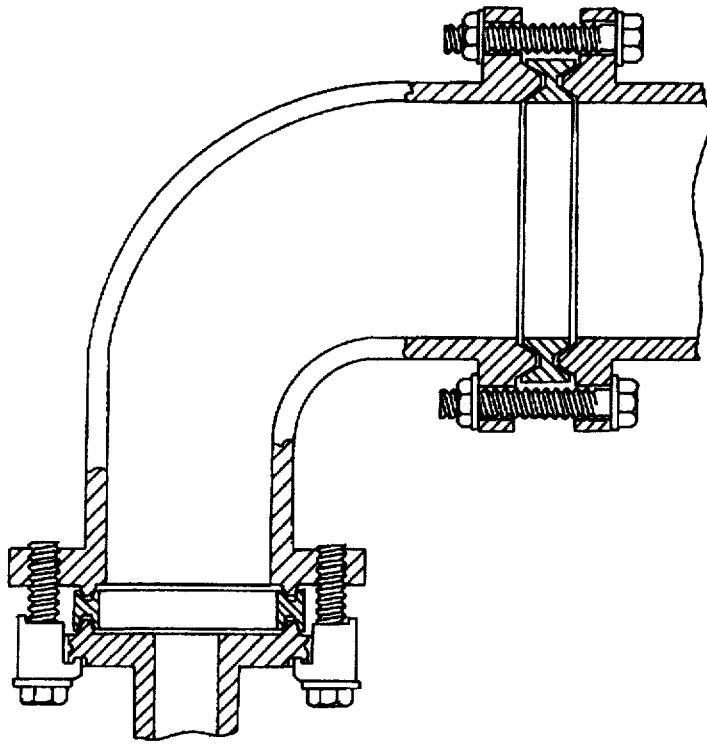

FIG. 12B

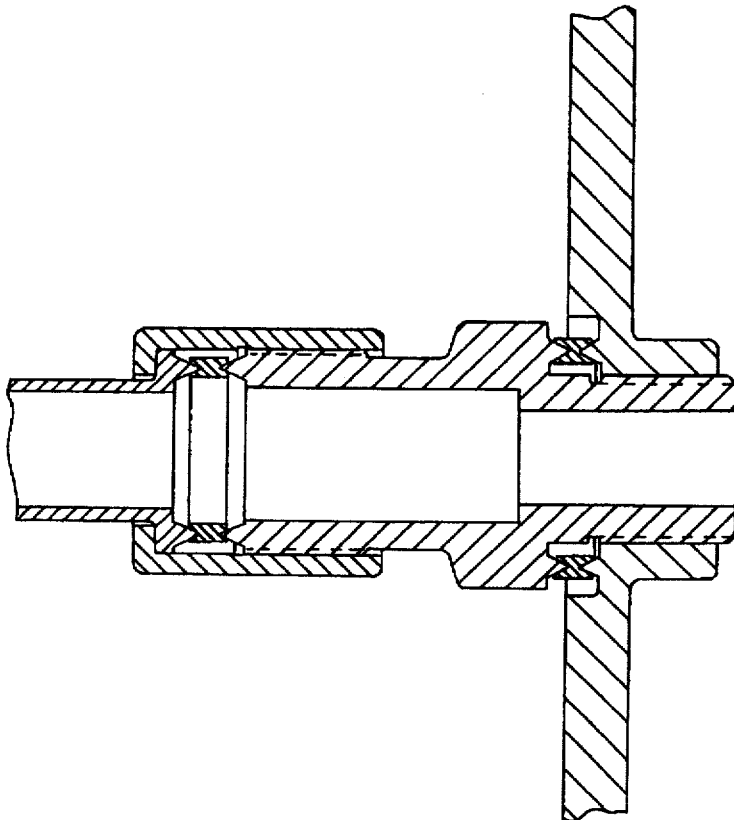

FIG. 12A

CONTRACTING/EXPANDING SELF-SEALING CRYOGENIC TUBE SEALS

The subject invention was made with government support under a research project supported by NASA-Kennedy Space Center and under Contract No. NAS10-11569 and Research Grant No. NAG10-0083. The government has certain rights in this invention.

BACKGROUND OF THE INVENTION

The rigorous conditions of very low operating temperatures coupled with high pressure impose extreme difficulties for controlling cryogen leakage from in-line tube fittings. The KC126 fitting, which has been used by NASA in the fuel lines of the space shuttle, has been found to leak. We have shown that the KC126 fitting leaks at 205K, and at 77K has a leak mass flux of 1.28×10^{-3} kg/min. See also Moore, Z., D. Capellin, A. Rodriguez, J. England (1988) "LH₂ TSM Leakage Problem," Interim Report: DM-MED-4, NASA, J.F.K. Space Center. Accordingly, there exists a need for an improved design of cryogenic seal for tube fittings such as those used in the space shuttle, and which is reusable and seals under extremes of low temperature and high pressure. Such a seal would have wide application in the cryogenic art.

The problem of sealing a joint between two interconnecting pieces that are designed to operate at cryogenic temperatures has been previously recognized. In part, this problem was addressed in U.S. Pat. No. 3,630,533, issued Dec. 28, 1971 to Butler et al., entitled "Dynamic Seal for Cryogenic Fluids." An additional problem addressed by Butler et al. is the high temperature sealing problem, which influenced Butler et al.'s design. Butler et al. used a circular sealing ring made from a fluorocarbon plastic material to seal two metal tubular couplings. The sealing ring is pressed onto a radially outward surface of one of the metal couplings. The sealing ring has a radially inward protruding annular rib which elastically and inelastically deforms as the sealing ring is pressed into place. This arrangement effects a sealing engagement between the sealing ring and the metal coupling at temperatures reported to be within the range of 70° F. to -423° F. At normal temperatures, the inner surface of the sealing ring is held in sealing engagement by the elastic preload induced by the initial interference press-fit and deformation of the protruding annular rib. In addition to the preload, a circumferential tension is generated in the sealing ring as the temperature decreases, because the sealing ring's coefficient of thermal expansion and contraction is greater than the coefficient of thermal expansion and contraction of the metal couplings. Thus, because of the differences in the expansion coefficients of the sealing ring and the metal coupling that it is pressed onto, the sealing engagement between these members of two different materials becomes tighter as the temperature decreases. However, in Butler et al.'s design, each time two metal tubular couplings are sealed together, the complex plastic sealing ring must be inelastically deformed into a particular configuration. Since the sealing ring is irreparably deformed by its installation, after separation of the two couplings for maintenance or other reasons, it is necessary to replace the sealing ring before the two couplings can be rejoined. Such a "use once and throw away" approach is wasteful, ultimately expensive, and troublesome if a replacement ring is not readily available. A coupling between two members which can be joined and separated, without requiring a new sealing ring each time, is needed.

BRIEF SUMMARY OF THE INVENTION

The subject invention, contracting/expanding self-sealing cryogenic tube seals, are thermal-contraction controlled-action sealing and gripping devices which utilize the differences of the thermal contraction of selected dissimilar materials in a specially designed and composed structure to self-tighten the seal via sloped-surface sealing between coupled members as the temperature decreases from ambient temperature. "Sloped-surface sealing" means that the contact points creating the seal are not the result of contact of parallel surfaces. In one preferred embodiment, the cooling process causes the contraction of a sealing spacer, further gripping the member ends, and causes the contraction of a housing nut, further forcing the coupling member ends together, thereby taking advantage of sloped-surface sealing in a novel way and preventing leakage of the flowing cryogen.

The contracting/expanding self-sealing cryogenic tube seals are leak-free from room temperature to cryogenic temperatures as low as that of liquid helium and, unlike anything known in the art, provide easily remountable tube connections for high pressure and low temperature applications.

The contracting/expanding self-sealing cryogenic tube seal is a general purpose cryogenic tube seal. It provides reliable leak-free connections for the low/high pressure and low temperature working conditions in cryogenic applications. It can be easily applied to various cryogenic fittings and valves. Some basic advantages of contracting self-sealing cryogenic fittings are summarized as follows:

1. Applicable to any low temperatures and temperature cycling.

2. Works on most common magnetic/non-magnetic tube materials.

3. Seals on machined surfaces.

4. Does not reduce the flow area.

5. Works on vacuum as well as low or high pressures.

6. Simple in structure for production and handling.

7. Easy to use, similar to the standard SAE fittings.

8. Easy to assemble and disassemble.

9. Ability to reuse without special maintenance or replacement.

10. Not sensitive to the applied coupling torques.

11. Not sensitive to the moment from other components.

12. Not corrosive for common cryogen.

13. Applicable to most cryogenic tube connections.

Design criteria for contracting/expanding self-sealing cryogenic (CESSC) tube seals are taught which must be applied in accord with the subject invention, and which depend on the properties of selected materials as well as the configuration of the seal. These criteria, illustrated by the following examples, enable the construction by means well known in the art of a tremendous number of varying embodiments, all of which are based on the novel sloped-sealing concepts taught herein, as will be readily apparent to the skilled artisan.

BRIEF DESCRIPTION OF THE DRAWINGS

FIG. 1 depicts a longitudinal section through a preferred embodiment of a contracting self-sealing cryogenic tube seal.

FIG. 2 depicts a longitudinal section through a variation of the embodiment depicted in FIG. 1, wherein the O-ring spacer has been replaced with a modified spacer.

FIG. 3 depicts a longitudinal section through an alternative embodiment of a contracting self-sealing cryogenic tube seal having only three components.

FIG. 4 depicts a longitudinal section through an alternative embodiment of the contracting self-sealing cryogenic tube seal.

FIG. 5 depicts the geometric analysis of cryogenic shrinkage of the components of the contracting self-sealing cryogenic tube seal.

FIG. 6 is a graphic representation of the design criteria for the contracting self-sealing cryogenic tube seal.

FIG. 7 depicts a longitudinal section through a preferred embodiment of a contracting/expanding self-sealing cryogenic tube seal.

FIG. 8 is a schematic drawing of an H-shaped spacer of a preferred embodiment of the contracting/expanding self-sealing cryogenic tube seal.

FIG. 9 depicts an H-shaped spacer of the contracting/expanding self-sealing cryogenic tube seal wherein the sloped surface sealing is accomplished via contact of curved surfaces.

FIG. 10 is a schematic drawing of a preferred embodiment of a coupling member of the contracting/expanding self-sealing cryogenic tube seal.

FIG. 11 is a schematic drawing of a preferred embodiment of the housing nut of the contracting/expanding self-sealing cryogenic tube seal.

FIG. 12 depicts various embodiments of the contracting/expanding self-sealing cryogenic tube seal in potential operational configurations.

Table 1

DETAILED DISCLOSURE OF THE INVENTION

Following are examples which illustrate procedures, including the best mode, for practicing the invention. These examples should not be construed as limiting.

EXAMPLE 1

A Preferred Embodiment

In a preferred embodiment, as depicted in FIG. 1, the contracting self-sealing cryogenic tube seal consists of four basic components: metal coupling members 1 and 2, each having a male an-flare tube end 14 and 15, respectively, an O-ring spacer 3, and a housing nut 4. Housing nut 4 comprises internal threads 13 for threaded engagement with external threads 5 and 6 on coupling members 1 and 2, respectively. The O-ring spacer 3 rests between two male an-flare coupling members 1 and 2.

Various parts of contracting self-sealing cryogenic tube seals are made of dissimilar solid bar metals, thereby taking advantage of their different coefficients of thermal contraction. The materials for O-ring spacer 3 and housing nut 4 have higher values of the coefficient of thermal contraction than does the material used for coupling members 1 and 2. In the preferred embodiment, the components are axisymmetric (symmetric about an axis).

Assembly of the contracting self-sealing cryogenic tube seal depicted in FIG. 1 is a simple matter of engaging housing nut 4 with coupling member 1 until the an-flare tube end 14 of coupling member 1 is positioned approximately in the middle of housing nut 4, proximal to the lateral plane represented by segment FG. O-ring spacer 3 is then inserted into housing nut 4 until it contacts an-flare tube end 14 of

coupling member 1. Coupling member 2 is then engaged into housing nut 4 until an-flare tube end 15 is secured against O-ring spacer 3. The sloped surface of the an-flare tube ends allows for contraction of the spacer while ensuring that a tight seal is maintained.

In operation, cryogenic fluid begins to flow through the contracting self-sealing cryogenic tube fitting along longitudinal axis ST as depicted in FIG. 1. For ease of discussion, movement toward position S will be referred to as "upward" and movement toward position T will be referred to as "downward;" movement toward axis ST will be referred to as "inward" and movement away from axis ST will be referred to as "outward." As the cryogenic fluid flows, the temperature of all parts of the contracting self-sealing cryogenic tube seal begins to decrease. Accordingly, the various parts of the tube seal shrink in size. Contact portion 10 at tube end 14 tends to shrink upward and inward. Contact portion 11 at O-ring spacer 3 tends to shrink downward and inward. That portion 18 of housing nut 4, which is depicted above lateral plane FG, tends to shrink downward and inward, while housing nut portion 19, below plane FG, tends to shrink upward and inward. Because O-ring spacer 3 and housing nut 4 are made of materials having a larger coefficient of thermal contraction than are coupling members 1 and 2 (and thus tube ends 14 and 15), the inward shrinkage of O-ring spacer 3 tends to cause it to press even more tightly against tube ends 14 and 15. Similarly, shrinkage of housing nut 4 tends to force tube ends 14 and 15 toward each other, as well as providing a tighter engagement of threaded portions 13, 5, and 6. Thus, the effects of thermal contraction will always maintain a leak-free seal in the contracting self-sealing cryogenic seal.

EXAMPLE 2

Some Alternative Embodiments

FIGS. 2, 3, and 4 depict exemplary alternative embodiments of the subject invention. To ensure proper sealing, contact surfaces of the components are axisymmetric. FIG. 2 depicts an embodiment similar to that depicted in FIG. 1 except that O-ring spacer 3 has been replaced with a flared spacer 27 having opposed female-flared contact surfaces 28 and 29, each having a complementary shape to tube ends 14 and 15, respectively, such that a tight seal is maintained therebetween in accord with the design criteria described hereinafter.

FIG. 3 depicts coupling member 1 with male an-flare tube end 14, coupling member 21 with female flare tube end 22, and housing nut 20, having a large bore at one end with internal threaded means for receiving and engaging coupling member 1 and a smaller (step down) bore at the other end, which is just large enough to surround coupling member 21, but not large enough to allow female flare tube end 22 to pass through. The internal surface of the step-down end of housing nut 20 defines a circumferential flange 23, radially sloping downward and outward. Housing nut 20 engages coupling member 1, and as housing nut 20 is tightened about coupling member 1, flange 23 engages a circumferential lip 24 on coupling member 21, lip 24 having a complementary slope to that of flange 23 such that contact is maintained between lip 24 and flange 23, and pulls coupling member 21 such that the female flare tube end 22 of coupling member 21 is thereby brought into contact with male an-flare tube end 14 of coupling member 1, similar to the method by which a garden house is brought into contact with a spigot. Secured contact between tube end 14 and tube end 22 is thereby maintained in accord with the disclosed design

criteria. To maintain the sloped-surface seal of this embodiment leak-free at cryogenic temperatures, coupling member 21 and housing nut 20 are made of materials having a larger coefficient of thermal expansion than the material of coupling member 1, all in accord with the design criteria. For example, coupling member 21 and housing nut 20 may be made of copper, if coupling member 1 is stainless steel.

The embodiment depicted in FIG. 4 combines features of the embodiments depicted in FIGS. 1 and 3. Housing nut 4 is engaged with coupling member 1 until the an-flare tube end 14 of coupling member 1 is positioned approximately in the middle of housing nut 4. Housing nut 4 then engages collar 25, which has external threaded means for being engaged and secured by the internal threaded means of housing nut 4, and which also has a wedge end 26 which engages lip 24 on coupling member 21 and forces female flare tube end 12 into secured contact with male an-flare tube end 14. Thus, it can be seen that the collar and wedge component of this embodiment can be used with housing nut 4 to effectively replace the flange 23 and small bore end of housing nut 20 of the embodiment depicted in FIG. 3. To maintain the sloped-surface seal of this embodiment leak-free at cryogenic temperatures, collar 25 (having wedge end 26), as well as coupling member 1, are made of materials having a smaller coefficient of thermal expansion than the material of housing nut 4 and coupling member 21 (having lip 24).

EXAMPLE 3

Design Criteria of Contracting/Expanding Self-Sealing Cryogenic Seals

According to the theory of Gas Dynamics and the linear analysis of thermal contraction, some criteria for the design of contracting/expanding self-sealing cryogenic seals are given below:

(1) Design criteria for two components—tube and spacer:

$$\alpha < \cos^{-1} \left\{ \left[\gamma_o + \left(\frac{\gamma_o - 1}{2\beta} \right)^2 \right]^{1/2} - \frac{\gamma_o - 1}{2\beta} \right\}$$

$$\beta < \frac{\gamma_o - 1}{\frac{\gamma_o}{\cos(\alpha)} - \cos(\alpha)}, \quad \gamma_o > \frac{1 - \beta \cos(\alpha)}{1 - \frac{\beta}{\cos(\alpha)}}$$

(2) Design criteria for three components—housing nut, tube-end, and spacer:

$$\gamma_o(T) > \frac{C_1(T)}{C_2}$$

where

$$C_1(T) = \sin \left[\alpha + 0 \tan^{-1} \left(\frac{1 - \beta \cos \alpha}{\frac{\lambda}{\tan \alpha} (1 - \gamma_h(T)) - \gamma_h(T) \beta \sin \alpha} \right) \right]$$

$$\left[(1 - \beta \cos \alpha)^2 + \left(\frac{\lambda}{\tan \alpha} (1 - \gamma_h(T)) - \gamma_h(T) \beta \sin \alpha \right)^2 \right]^{1/2}$$

$$C_2 = (\cos \alpha - \beta)$$

Referring to FIG. 5, α is the an-flared angle of the tube ends, β is the radius ratio of O-ring spacer r_1/R , λ is the ratio of the thickness of tube-end to the radius of the spacer, w/R , γ_o ($\gamma_o = \epsilon_o/\epsilon_p$) is the ratio of thermal contraction of the material used for the spacer to that of the tube ends, γ_h ($\gamma_h = \epsilon_h/\epsilon_p$) is the ratio of thermal contraction of the material used for the housing-nut to that of the tube ends. The parameters, α , β ,

and λ , are the parameters of the seal geometry. γ_o and γ_h are the functions of temperature, which can be found from the tables of material properties and are well known in the art.

These criteria have been illustrated in the graphs of FIG. 6. The physics of the thermal contracting process or the thermal and geometric effects of the contracting/expanding self-sealing cryogenic seal is revealed by these criteria. The contracting/expanding self-sealing cryogenic seal is predictable in its response to temperature fluctuations—it consistently fulfills the promise of self-sealing for cryogenic applications.

A linear approximation of the sealing process in a thermal-contraction controlled-action seal by a simple geometric analysis was used to calculate design parameters of the contracting/expanding self-sealing cryogenic seal. The contracting self-sealing cryogenic tube seals exemplified herein were designed in accord with this analysis and have successfully passed a series of tests in the cryogenic leak test system with a temperature drop from room temperature down to the liquid helium temperature in the Cryogenic Laboratory of Florida Atlantic University.

Shown in FIG. 5 is the cross-section of an O-ring spacer seated between an-flared tube ends with axial angle, α , before and after cooling period. Both O-ring spacer and tube end, which have different coefficients of thermal expansion, shrink axisymmetrically in the cooling process. A_1 and A_2 are two contact points of the mating parts before and after cooling. Because of the thermal contraction, the original contact point, A_1 , in the tube end moves to D, with a radial shrinkage, $\Delta t = A_1 E$, and an axial shrinkage, $\Delta L = ED$.

A maximum value of the shrinkage of the tube end in axial direction, ΔL , can be obtained if presuming a zero-thermal-stress condition, which means free contracting of both O-ring spacer and tube end without losing contact with each other. It is apparent that if the actual axial shrinkage of the tube end is larger than the zero-thermal-stress shrinkage, ΔL , the contracting self-sealing cryogenic seal will never achieve a leak-free seal.

From the geometry in FIG. 5, if we let $\Delta L' = A_1 B$ and $\Delta t' = A_1 C$, then

$$\frac{\Delta L}{\Delta L'} = \frac{\Delta t' - \Delta t}{\Delta t'}$$

and $\Delta t' = \Delta L' \tan \alpha$, we have

$$\Delta L = \Delta L' - \frac{\Delta t}{\tan \alpha} \quad (1)$$

and also,

$$\Delta L' \sin \alpha + r_1 = \Delta R \cos \alpha + r_2$$

we have,

$$\Delta L' = \frac{\Delta R}{\tan \alpha} - \frac{\Delta r}{\sin \alpha} \quad (2)$$

where $\Delta r = r_1 r_2$. Combining Eq. (1) and (2),

$$\Delta L = \frac{1}{\tan \alpha} \left(\Delta R - \Delta t - \frac{\Delta r}{\cos \alpha} \right) \quad (3)$$

Assuming a linear contraction as a first approximation, i.e., $\Delta R = \epsilon_p R$, since r is much smaller than R , and $\Delta t = \epsilon_o r_1$ and $\Delta t = \epsilon_p (R - r_1 \cos \alpha)$ for the same approximation, where ϵ and ϵ_p are the coefficients of thermal expansion of O-ring spacer and tube end, respectively. Substituting ΔR , Δt , and

Δr into Eq. (3), we have,

$$\Delta L = \frac{1}{\tan \alpha} \left[R(\epsilon_o - \epsilon_p) - r_1 \left(\frac{\epsilon_o}{\cos \alpha} - \epsilon_p \cos \alpha \right) \right] \quad (4)$$

Let $\gamma = \epsilon_o / \epsilon_p$, and $\beta = r_1 / R$, we can rewrite Eq. (4) as

$$\Delta L = \frac{R\epsilon_p}{\tan \alpha} \left[\gamma \left(1 - \frac{\beta}{\cos \alpha} \right) + \beta \cos \alpha - 1 \right] \quad (5)$$

The maximum axial shrinkage of tube end, ΔL , from the above equation, is a function of three parameters, α , β , and γ , where α is the an-flared angle of the tube end, β is the radius ratio of the O-ring spacer, and γ is the ratio of thermal properties of material used for two mating parts.

In order to have a positive value of ΔL , the term in brackets must be positive, which leads to three design criteria for three parameters, each one depending on the other two, which are given as follows:

$$\gamma > \frac{1 - \beta \cos \alpha}{1 - \frac{\beta}{\cos \alpha}} \quad (A)$$

$$\beta < \frac{\gamma - 1}{\frac{\gamma}{\cos \alpha} - \cos \alpha} \quad (B)$$

$$\alpha < \cos^{-1} \left\{ \left[\gamma + \left(\frac{\gamma - 1}{2\beta} \right)^2 \right]^{1/2} - \frac{\gamma - 1}{2\beta} \right\} \quad (C)$$

According to the above criteria, α and β do not have lower limitations except for the negative values, which are meaningless for an O-ring seal. The lower limitations actually depend on the strength of the materials. The minimum value of α depends on the requirement for the wall thickness of the tube end. The minimum value of β depends on the requirement for the radius of the cross section of the O-ring spacer. The graphs of FIG. 6 represent possible values for α , β , and γ that can be used for the design of contracting self-sealing cryogenic seal. In Table 1, a dimensionless parameter of $\Delta L / R\epsilon_p$, is given which is computed from Eq. (5) for the convenience of applications. For example, if we choose $\alpha = 35^\circ$, and $\beta = 0.3$, then γ must be larger than 1.2. If we chose $\gamma = 6$ (for copper O-ring and invar tube end), we have $\Delta L / R\epsilon_p = 4.5$. If $R = 8$ mm, and $\epsilon_p = 0.06\%$ (invar at 6K), the maximum promising axial shrinkage, $\Delta L = 0.022$ mm. This is an approximate value for the tested contracting self-sealing cryogenic seal at liquid helium temperature.

EXAMPLE 4

Selection of Materials for Contracting/Expanding Self-Sealing Cryogenic Seals

The function of a contracting/expanding self-sealing cryogenic seal relies upon the differences of the thermal contractions of dissimilar materials in a specially composed structure which, in a novel, advantageous manner uses the concept of sloped-surface sealing. The selection of materials is basically determined by the nature of thermal contraction of the materials used for each of the components. The contracting/expanding self-sealing cryogenic seal works only if it is designed to meet the criteria which are dependent upon not only the thermal properties of materials, but also the geometric parameters. The selection of the materials, therefore, is not an independent factor in order to achieve a self-sealing purpose. It must be considered together with the geometric parameters of the components of the seal. In this regard, the contracting self-sealing cryogenic seal is an integrated unit.

One of the possible combinations is given as follows: The material for tube ends is commonly the same as that for the tubing bodies. For cryogenic situations, stainless steel is a commonly-used material for tubing bodies. Therefore, among other common engineering materials, in the embodiment depicted in FIG. 1, copper is one of the possible choices for the housing nut and the O-ring spacer, used with the stainless steel tube ends. However, the geometric configuration must meet the contracting self-sealing cryogenic criteria disclosed above with the given parameter of thermal contraction ratio calculated for copper to stainless steel.

EXAMPLE 5

Test Results of Various Embodiments of Contracting Self-Sealing Cryogenic Seal

The contracting self-sealing cryogenic seals have passed a series of tests in the cryogenic leak test system at Florida Atlantic University. The detailed information of the cryogenic leak test system is given in Jia, L. X., D. Moslemian, W. L. Chow (1992) "Cryogenic leak testing of tube fittings/valves," *Cryogenics* 32(9):833-839, which is incorporated herein by reference thereto. The tests were conducted under two different temperature levels, LN₂ temperature (≈ 77 K), and LHe temperature (≈ 4 K).

For the leak test under LN₂ temperature, the highest internal pressure against the external vacuum applied to this seal has been 31×10^5 Pa, nearly two times the working pressure in the space shuttle. The test lasted about ten hours without showing any signs of leak from vacuum gauges at pressure of 5×10^{-4} Bar within the sample chamber. In another test, initial pressurization was to 27.1×10^5 Pa. As the temperature dropped to 140K, additional gaseous helium was supplied to increase the internal pressure from 12×10^5 Pa to 26.2×10^5 Pa. When the equilibrium temperature of 77K was reached, internal pressure was reduced down to 17.2×10^5 Pa and kept under this condition for another 10 hours. Throughout the testing period, no pressure increase was detected in the evacuated sample chamber used to house the seal.

For the leak test under LHe temperature, a constant internal pressure of 27.1×10^5 Pa against the external vacuum was applied to the contracting self-sealing cryogenic tube seal. The test lasted 5 hours at the temperature of 4.5K-6.9K without showing any signs of leak from vacuum gauges at pressure of 1×10^{-6} Bar within the sample chamber. The tests on the contracting self-sealing cryogenic tube seals at LHe temperature indicated that it is feasible to develop a new series of cryogenic tube seals for the LH₂ transfer lines of the space shuttle, as well as for other cryogenic applications, based on the novel sloped-sealing technology taught herein.

EXAMPLE 6

Contracting/Expanding Self-Sealing Cryogenic Seal

The concept for a contracting self-sealing cryogenic tube seal can be extended for a special application where a wide range and high rate of temperature cycling is a significant feature of the working condition. A contracting/expanding self-sealing cryogenic tube fitting is schematically shown in FIG. 7. With larger thermal contraction and thermal expansion coefficients, the shrinking or expanding displacement of the spacer caused by temperature cycling always tends to prevent the appearance of any possible leak gap between the tube ends and the spacer, no matter whether the working temperature is decreasing or increasing. A similar analysis

for a contracting/expanding self-sealing cryogenic seal can be easily obtained as described above by considering an additional reverse thermal process of temperature increase.

In a contracting/expanding self-sealing cryogenic seal as depicted in FIG. 7, the spacer 30 has an H-shaped cross-section, having opposed V-shaped female sloped-sealing surfaces 31 and 32 at each end which contact the complementary sloped male an-flare tube ends 39 and 40, respectively, of the coupling members 37 and 38. The male angle of the tube end is made slightly larger than the female angle of the corresponding surface of the spacer 30. A similar H-shaped spacer/seal is depicted in FIG. 9, wherein the sloped surface sealing is accomplished by contact of curved surfaces. When temperature is decreased, the outwardmost contact surfaces 33 and 34 of the spacer 30 will tightly grip the tube ends 39 and 40. When temperature is increased, the inside contact surfaces 35 and 36 of the spacer 30 will tightly press against the tube ends 39 and 40. Therefore, a tight seal is achieved under the temperature cycling condition. Since the temperature changes in two opposite directions, the thermal behavior of the housing nut 41 no longer contributes consistently for tube sealing during the temperature cycling. Therefore, in a preferred embodiment, the material for the housing nut 41 has a smaller coefficient of thermal contraction (or expansion) than does the spacer 30. The material for coupling members 37 and 38 also has a smaller coefficient of thermal expansion than does that of spacer 30. The selection of materials for the spacer 30 and tube ends 39 and 40 of contracting/expanding self-sealing cryogenic seals follows the same design criteria given above. In a preferred embodiment, the subject seal, seemingly sophisticated, surprisingly simply solves sometimes severe system seepage substantially superior to standard space shuttle seals by specially-selected, securely sandwiched, sloped-surface spacers snugly surrounding stainless steel surfaces shown self-sealing by sequential shrinking and swelling.

One preferred embodiment of the contracting/expanding self-sealing cryogenic seal was fabricated for use in the LH₂ lines of the space shuttle at the JFK Space Center. The H-shaped spacer 30 (see FIGS. 7 and 8) has a larger thermal expansion coefficient than that of the tube ends 39 and 40 between which it is sandwiched. Shrinkage or expansion of this spacer always tends to prevent the formation of any possible leaking gap between the tube ends and the spacer, regardless of whether the working temperature is decreasing or increasing. The contracting/expanding self-sealing cryogenic tube seal provides leak-free and easily remountable tube connections from temperatures as high as the component materials can withstand to cryogenic temperatures as low as that of liquid helium, and under pressures varying from vacuum to several hundred psi or more. The seal is especially effective in applications where a wide range and high rate temperature cycling are significant features of the working conditions. The seal can be easily integrated into all kinds of cryogenic tubing components, such as fittings and valves. Several possible configurations which employ the contracting/expanding self-sealing cryogenic tube seal are shown in FIG. 12. The contracting/expanding self-sealing cryogenic seal has passed the temperature cycling test: first cooled down from 296K to 12K, then heated up to 300K within 20 minutes, and then cooled down again to 77K, while the pressure maintained 400 psig, without showing any sign of leak.

It should be understood that the examples and embodiments described herein are for illustrative purposes only and that various modifications or changes in light thereof will be

suggested to persons skilled in the art and are to be included within the spirit and purview of this application and the scope of the appended claims.

TABLE 1

Design Parameters for CSSC Tube Fitting, (d1 = ΔL/Rε _s).				
	gama(beta = 0.1000000	beta	alfa = 5) >	1.000848
	gama	beta	alfa	
10	dl(1.000848	0.1000000	5	= 0.0000000E + 00
	dl(1.500848	0.1000000	5	= 5.141342
	dl(2.000848	0.1000000	5	= 10.28268
	dl(2.500848	0.1000000	5	= 15.42402
	dl(3.000848	0.1000000	5	= 20.56536
	dl(3.500848	0.1000000	5	= 25.70670
15	dl(4.000848	0.1000000	5	= 30.84805
	dl(4.500848	0.1000000	5	= 35.98938
	dl(5.000848	0.1000000	5	= 41.13073
	dl(5.500848	0.1000000	5	= 46.27207
	dl(6.000848	0.1000000	5	= 51.41341
	gama(beta = 0.1000000	beta	alfa = 10) >	1.003408
20	dl(1.003408	0.1000000	10	= 0.0000000E + 00
	dl(1.503408	0.1000000	10	= 2.547703
	dl(2.003408	0.1000000	10	= 5.095405
	dl(2.503408	0.1000000	10	= 7.643107
	dl(3.003408	0.1000000	10	= 10.19081
	dl(3.503408	0.1000000	10	= 12.73851
25	dl(4.003408	0.1000000	10	= 15.28621
	dl(4.503408	0.1000000	10	= 17.83392
	dl(5.003408	0.1000000	10	= 20.38162
	dl(5.503408	0.1000000	10	= 22.92932
	dl(6.003408	0.1000000	10	= 25.47702
	gama(beta = 0.1000000	beta	alfa = 15) >	1.007736
30	dl(1.007736	0.1000000	15	= 0.0000000E + 00
	dl(1.507736	0.1000000	15	= 1.672840
	dl(2.007736	0.1000000	15	= 3.345681
	dl(2.507736	0.1000000	15	= 5.018521
	dl(3.007736	0.1000000	15	= 6.691361
35	dl(3.507736	0.1000000	15	= 8.364202
	dl(4.007736	0.1000000	15	= 10.03704
	dl(4.507736	0.1000000	15	= 11.70988
	dl(5.007736	0.1000000	15	= 13.38272
	dl(5.507736	0.1000000	15	= 15.05556
	dl(6.007736	0.1000000	15	= 16.72840
	gama(beta = 0.1000000	beta	alfa = 20) >	1.013931
40	dl(1.013931	0.1000000	20	= 0.0000000E + 00
	dl(1.513931	0.1000000	20	= 1.227548
	dl(2.013931	0.1000000	20	= 2.455097
	dl(2.513931	0.1000000	20	= 3.682646
	dl(3.013931	0.1000000	20	= 4.910194
45	dl(3.513931	0.1000000	20	= 6.137743
	dl(4.013931	0.1000000	20	= 7.365292
	dl(4.513931	0.1000000	20	= 8.592841
	dl(5.013931	0.1000000	20	= 9.820390
	dl(5.513931	0.1000000	20	= 11.04794
	dl(6.013931	0.1000000	20	= 12.27549
	gama(beta = 0.1000000	beta	alfa = 25) >	1.022151
50	dl(1.022151	0.1000000	25	= 0.0000000E + 00
	dl(1.522151	0.1000000	25	= 0.9539434
	dl(2.022151	0.1000000	25	= 1.907887
	dl(2.522151	0.1000000	25	= 2.861830
55	dl(3.022151	0.1000000	25	= 3.815774
	dl(3.522151	0.1000000	25	= 4.769717
	dl(4.022151	0.1000000	25	= 5.723660
	dl(4.522151	0.1000000	25	= 6.677603
	dl(5.022151	0.1000000	25	= 7.631547
	dl(5.522151	0.1000000	25	= 8.585490
	dl(6.022151	0.1000000	25	= 9.539434
	gama(beta = 0.1000000	beta	alfa = 30) >	1.032636
60	dl(1.032636	0.1000000	30	= 0.0000000E + 00
	dl(1.532636	0.1000000	30	= 0.7660255
	dl(2.032636	0.1000000	30	= 1.532051
	dl(2.532636	0.1000000	30	= 2.298077
65	dl(3.032636	0.1000000	30	= 3.064102
	dl(3.532636	0.1000000	30	= 3.830127

TABLE 1-continued

TABLE 1-continued

Design Parameters for CSSC Tube Fitting, ($d1 = \Delta L/R_{ep}$).

	gama	beta	alfa		
dl(4.032636	0.1000000	30)= 4.596153	
dl(4.532636	0.1000000	30)= 5.362179	
dl(5.032636	0.1000000	30)= 6.128204	
dl(5.532636	0.1000000	30)= 6.894230	
dl(6.032636	0.1000000	30)= 7.660254	
gama(beta = 0.1000000 alfa = 35) >				1.045747	
gama				beta	alfa
dl(1.045747	0.1000000	35)= 0.0000000E + 00	
dl(1.545747	0.1000000	35)= 0.6269017	
dl(2.045747	0.1000000	35)= 1.253803	
dl(2.545747	0.1000000	35)= 1.880705	
dl(3.045747	0.1000000	35)= 2.507607	
dl(3.545747	0.1000000	35)= 3.134508	
dl(4.045747	0.1000000	35)= 3.761410	
dl(4.545747	0.1000000	35)= 4.388311	
dl(5.045747	0.1000000	35)= 5.015213	
dl(5.545747	0.1000000	35)= 5.642115	
dl(6.045747	0.1000000	35)= 6.269017	
gama(beta = 0.1000000 alfa = 40) >				1.062034	
gama				beta	alfa
dl(1.062034	0.1000000	40)= -7.1034052E - 08	
dl(1.562034	0.1000000	40)= 0.5180907	
dl(2.062034	0.1000000	40)= 1.036181	
dl(2.562034	0.1000000	40)= 1.554272	
dl(3.062034	0.1000000	40)= 2.072362	
dl(3.562034	0.1000000	40)= 2.590453	
dl(4.062034	0.1000000	40)= 3.108544	
dl(4.562034	0.1000000	40)= 3.626635	
dl(5.062034	0.1000000	40)= 4.144725	
dl(5.562034	0.1000000	40)= 4.662816	
dl(6.062034	0.1000000	40)= 5.180906	
gama(beta = 0.1000000 alfa = 45) >				1.082358	
gama				beta	alfa
dl(1.082358	0.1000000	45)= 0.0000000E + 00	
dl(1.582358	0.1000000	45)= 0.4292893	
dl(2.082358	0.1000000	45)= 0.8585786	
dl(2.582358	0.1000000	45)= 1.287868	
dl(3.082358	0.1000000	45)= 1.717157	
dl(3.582358	0.1000000	45)= 2.146446	
dl(4.082358	0.1000000	45)= 2.575736	
dl(4.582358	0.1000000	45)= 3.005025	
dl(5.082358	0.1000000	45)= 3.434314	
dl(5.582358	0.1000000	45)= 3.863604	
dl(6.082358	0.1000000	45)= 4.292893	
gama(beta = 0.1000000 alfa = 50) >				1.108113	
gama				beta	alfa
dl(1.108113	0.1000000	50)= 0.0000000E + 00	
dl(1.608113	0.1000000	50)= 0.3542794	
dl(2.108113	0.1000000	50)= 0.7085589	
dl(2.608113	0.1000000	50)= 1.062838	
dl(3.108113	0.1000000	50)= 1.417118	
dl(3.608113	0.1000000	50)= 1.771397	
dl(4.108113	0.1000000	50)= 2.125677	
dl(4.608113	0.1000000	50)= 2.479956	
dl(5.108113	0.1000000	50)= 2.834235	
dl(5.608113	0.1000000	50)= 3.188515	
dl(6.108113	0.1000000	50)= 3.542794	
gama(beta = 0.1000000 alfa = 55) >				1.141690	
gama				beta	alfa
dl(1.141690	0.1000000	55)= 0.0000000E + 00	
dl(1.641690	0.1000000	55)= 0.2890651	
dl(2.141690	0.1000000	55)= 0.5781302	
dl(2.641690	0.1000000	55)= 0.8671951	
dl(3.141690	0.1000000	55)= 1.156260	
dl(3.641690	0.1000000	55)= 1.445325	
dl(4.141690	0.1000000	55)= 1.734390	
dl(4.641690	0.1000000	55)= 2.023455	
dl(5.141690	0.1000000	55)= 2.312521	
dl(5.641690	0.1000000	55)= 2.601585	
dl(6.141690	0.1000000	55)= 2.890651	
gama(beta = 0.1000000 alfa = 60) >				1.187500	
gama				beta	alfa
dl(1.187500	0.1000000	60)= 0.0000000E + 00	
dl(1.687500	0.1000000	60)= 0.2309401	
dl(2.187500	0.1000000	60)= 0.4618802	
dl(2.687500	0.1000000	60)= 0.6928203	
dl(3.187500	0.1000000	60)= 0.9237604	

Design Parameters for CSSC Tube Fitting, ($d1 = \Delta L/R_{ep}$).

5	dl(3.687500	0.1000000	60)= 1.154701
	dl(4.187500	0.1000000	60)= 1.385641
	dl(4.687500	0.1000000	60)= 1.616581
	dl(5.187500	0.1000000	60)= 1.847521
	dl(5.687500	0.1000000	60)= 2.078461
	dl(6.187500	0.1000000	60)= 2.309401
gama(beta = 0.1000000 alfa = 65) >				1.254602	
gama				beta	alfa
10	dl(1.254602	0.1000000	65)= 0.0000000E + 00
	dl(1.754602	0.1000000	65)= 0.1779849
	dl(2.254602	0.1000000	65)= 0.3559698
	dl(2.754602	0.1000000	65)= 0.5339549
15	dl(3.254602	0.1000000	65)= 0.7119397
	dl(3.754602	0.1000000	65)= 0.8899247
	dl(4.254602	0.1000000	65)= 1.067910
	dl(4.754602	0.1000000	65)= 1.245895
	dl(5.254602	0.1000000	65)= 1.423879
	dl(5.754602	0.1000000	65)= 1.601864
	dl(6.254602	0.1000000	65)= 1.779849
gama(beta = 0.1000000 alfa = 70) >				1.364855	
gama				beta	alfa
20	dl(1.364855	0.1000000	70)= 0.0000000E + 00
	dl(1.864855	0.1000000	70)= 0.1287762
	dl(2.364855	0.1000000	70)= 0.2575525
	dl(2.864855	0.1000000	70)= 0.3863288
25	dl(3.364855	0.1000000	70)= 0.5151050
	dl(3.864855	0.1000000	70)= 0.6438813
	dl(4.364855	0.1000000	70)= 0.7726575
	dl(4.864855	0.1000000	70)= 0.9014338
	dl(5.364855	0.1000000	70)= 1.030210
	dl(5.864855	0.1000000	70)= 1.158986
	dl(6.364855	0.1000000	70)= 1.287763
gama(beta = 0.1000000 alfa = 75) >				1.587469	
gama				beta	alfa
30	dl(1.587469	0.1000000	75)= 0.0000000E + 00
	dl(2.087469	0.1000000	75)= 8.2210816E - 02
	dl(2.587469	0.1000000	75)= 0.1644216
35	dl(3.087469	0.1000000	75)= 0.2466324
	dl(3.587469	0.1000000	75)= 0.3288433
	dl(4.087469	0.1000000	75)= 0.4110541
	dl(4.587469	0.1000000	75)= 0.4932648
	dl(5.087469	0.1000000	75)= 0.5754756
	dl(5.587469	0.1000000	75)= 0.6576865
40	dl(6.087469	0.1000000	75)= 0.7398973
	dl(6.587469	0.1000000	75)= 0.8221080
gama(beta = 0.1000000 alfa = 80) >				2.316863	
gama				beta	alfa
45	dl(2.316863	0.1000000	80)= -1.0509909E - 08
	dl(2.816863	0.1000000	80)= 3.7392177E - 02
	dl(3.316863	0.1000000	80)= 7.4784376E - 02
	dl(3.816863	0.1000000	80)= 0.1121766
	dl(4.316863	0.1000000	80)= 0.1495687
	dl(4.816863	0.1000000	80)= 0.1869609
	dl(5.316863	0.1000000	80)= 0.2243531
	dl(5.816863	0.1000000	80)= 0.2617453
	dl(6.316863	0.1000000	80)= 0.2991375
50	dl(6.816863	0.1000000	80)= 0.3365296
	dl(7.316863	0.1000000	80)= 0.3739218
gama(beta = 0.2000000 alfa = 5) >				1.001908	
gama				beta	alfa
55	dl(1.001908	0.2000000	5)= 0.0000000E + 00
	dl(1.501908	0.2000000	5)= 4.567655
	dl(2.001908	0.2000000	5)= 9.135310
	dl(2.501908	0.2000000	5)= 13.70297
	dl(3.001908	0.2000000	5)= 18.27062
	dl(3.501908	0.2000000	5)= 22.83828
	dl(4.001908	0.2000000	5)= 27.40593
	dl(4.501908	0.2000000	5)= 31.97359
	dl(5.001908	0.2000000	5)= 36.54124
60	dl(5.501908	0.2000000	5)= 41.10890
	dl(6.001908	0.2000000	5)= 45.67656
gama(beta = 0.2000000 alfa = 10) >				1.007684	
gama				beta	alfa
65	dl(1.007684	0.2000000	10)= 0.0000000E + 00
	dl(1.507684	0.2000000	10)= 2.259764
	dl(2.007684	0.2000000	10)= 4.519529
	dl(2.507684	0.2000000	10)= 6.779292

TABLE 1-continued

Design Parameters for CSSC Tube Fitting, (d1 = ΔL/R _e).				
	gama	beta	alfa	
dl(3.007684	0.2000000	10	9.039058
dl(3.507684	0.2000000	10	11.29882
dl(4.007684	0.2000000	10	13.55858
dl(4.507684	0.2000000	10	15.81835
dl(5.007684	0.2000000	10	18.07811
dl(5.507684	0.2000000	10	20.33787
dl(6.007684	0.2000000	10	22.59764
gama(beta = 0.2000000 alfa = 15) >				1.017492
dl(1.017492	0.2000000	15	0.0000000E + 00
dl(1.517492	0.2000000	15	1.479655
dl(2.017492	0.2000000	15	2.959310
dl(2.517492	0.2000000	15	4.438965
dl(3.017492	0.2000000	15	5.918621
dl(3.517492	0.2000000	15	7.398275
dl(4.017492	0.2000000	15	8.877931
dl(4.517492	0.2000000	15	10.35759
dl(5.017492	0.2000000	15	11.83724
dl(5.517492	0.2000000	15	13.31690
dl(6.017492	0.2000000	15	14.79655
gama(beta = 0.2000000 alfa = 20) >				1.031629
dl(1.031629	0.2000000	20	0.0000000E + 00
dl(1.531629	0.2000000	20	1.081358
dl(2.031629	0.2000000	20	2.162717
dl(2.531629	0.2000000	20	3.244075
dl(3.031629	0.2000000	20	4.325433
dl(3.531629	0.2000000	20	5.406792
dl(4.031629	0.2000000	20	6.488149
dl(4.531629	0.2000000	20	7.569508
dl(5.031629	0.2000000	20	8.650867
dl(5.531629	0.2000000	20	9.732225
dl(6.031629	0.2000000	20	10.81358
gama(beta = 0.2000000 alfa = 25) >				1.050575
dl(1.050575	0.2000000	25	0.0000000E + 00
dl(1.550575	0.2000000	25	0.8356334
dl(2.050575	0.2000000	25	1.671267
dl(2.550575	0.2000000	25	2.506900
dl(3.050575	0.2000000	25	3.342533
dl(3.550575	0.2000000	25	4.178166
dl(4.050575	0.2000000	25	5.013800
dl(4.550575	0.2000000	25	5.849433
dl(5.050575	0.2000000	25	6.685066
dl(5.550575	0.2000000	25	7.520700
dl(6.050575	0.2000000	25	8.356333
gama(beta = 0.2000000 alfa = 30) >				1.075072
dl(1.075072	0.2000000	30	-1.0323828E - 07
dl(1.575072	0.2000000	30	0.6660254
dl(2.075072	0.2000000	30	1.332051
dl(2.575072	0.2000000	30	1.998076
dl(3.075072	0.2000000	30	2.664102
dl(3.575072	0.2000000	30	3.330127
dl(4.075072	0.2000000	30	3.996153
dl(4.575072	0.2000000	30	4.662178
dl(5.075072	0.2000000	30	5.328203
dl(5.575072	0.2000000	30	5.994229
dl(6.075072	0.2000000	30	6.660254
gama(beta = 0.2000000 alfa = 35) >				1.106271
dl(1.106271	0.2000000	35	0.0000000E + 00
dl(1.606271	0.2000000	35	0.5397293
dl(2.106271	0.2000000	35	1.079459
dl(2.606271	0.2000000	35	1.619188
dl(3.106271	0.2000000	35	2.158918
dl(3.606271	0.2000000	35	2.698647
dl(4.106271	0.2000000	35	3.238376
dl(4.606271	0.2000000	35	3.778105
dl(5.106271	0.2000000	35	4.317834
dl(5.606271	0.2000000	35	4.857564
dl(6.106271	0.2000000	35	5.397293
gama(beta = 0.2000000 alfa = 40) >				1.145987
dl(1.145987	0.2000000	40	0.0000000E + 00
dl(1.645987	0.2000000	40	0.4403043
dl(2.145987	0.2000000	40	0.8806087

TABLE 1-continued

Design Parameters for CSSC Tube Fitting, (d1 = ΔL/R _e).				
	gama	beta	alfa	
5 dl(2.645987	0.2000000	40	1.320913
dl(3.145987	0.2000000	40	1.761218
dl(3.645987	0.2000000	40	2.201522
dl(4.145987	0.2000000	40	2.641827
dl(4.645987	0.2000000	40	3.082131
dl(5.145987	0.2000000	40	3.522435
10 dl(5.645987	0.2000000	40	3.962740
dl(6.145987	0.2000000	40	4.403044
gama(beta = 0.2000000 alfa = 45) >				1.197197
dl(1.197197	0.2000000	45	0.0000000E + 00
dl(1.697197	0.2000000	45	0.3585786
15 dl(2.197197	0.2000000	45	0.7171574
dl(2.697197	0.2000000	45	1.075736
dl(3.197197	0.2000000	45	1.434315
dl(3.697197	0.2000000	45	1.792893
dl(4.197197	0.2000000	45	2.151472
dl(4.697197	0.2000000	45	2.510051
20 dl(5.197197	0.2000000	45	2.868629
dl(5.697197	0.2000000	45	3.227208
dl(6.197197	0.2000000	45	3.585786
gama(beta = 0.2000000 alfa = 50) >				1.265059
dl(1.265059	0.2000000	50	0.0000000E + 00
dl(1.765059	0.2000000	50	0.2890092
25 dl(2.265059	0.2000000	50	0.5780182
dl(2.765059	0.2000000	50	0.8670272
dl(3.265059	0.2000000	50	1.156036
dl(3.765059	0.2000000	50	1.445045
dl(4.265059	0.2000000	50	1.734055
dl(4.765059	0.2000000	50	2.023064
30 dl(5.265059	0.2000000	50	2.312073
dl(5.765059	0.2000000	50	2.601082
dl(6.265059	0.2000000	50	2.890091
gama(beta = 0.2000000 alfa = 55) >				1.359236
dl(1.359236	0.2000000	55	0.0000000E + 00
35 dl(1.859236	0.2000000	55	0.2280263
dl(2.359236	0.2000000	55	0.4560528
dl(2.859236	0.2000000	55	0.6840791
dl(3.359236	0.2000000	55	0.9121054
dl(3.859236	0.2000000	55	1.140132
dl(4.359236	0.2000000	55	1.368158
40 dl(4.859236	0.2000000	55	1.596184
dl(5.359236	0.2000000	55	1.824211
dl(5.859236	0.2000000	55	2.052237
dl(6.359236	0.2000000	55	2.280263
gama(beta = 0.2000000 alfa = 60) >				1.500000
dl(1.500000	0.2000000	60	0.0000000E + 00
45 dl(2.000000	0.2000000	60	0.1732051
dl(2.500000	0.2000000	60	0.3464102
dl(3.000000	0.2000000	60	0.5196153
dl(3.500000	0.2000000	60	0.6928202
dl(4.000000	0.2000000	60	0.8660252
dl(4.500000	0.2000000	60	1.039230
50 dl(5.000000	0.2000000	60	1.212435
dl(5.500000	0.2000000	60	1.385640
dl(6.000000	0.2000000	60	1.558846
dl(6.500000	0.2000000	60	1.732051
gama(beta = 0.2000000 alfa = 65) >				1.737939
dl(1.000848	0.2000000	65	0.0000000E + 00
55 dl(2.237939	0.2000000	65	0.1228161
dl(2.737939	0.2000000	65	0.2456321
dl(3.237939	0.2000000	65	0.3684481
dl(3.737939	0.2000000	65	0.4912642
dl(4.237939	0.2000000	65	0.6140803
60 dl(4.737939	0.2000000	65	0.7368963
dl(5.237939	0.2000000	65	0.8597122
dl(5.737939	0.2000000	65	0.9825283
dl(6.237939	0.2000000	65	1.105344
dl(6.737939	0.2000000	65	1.228161
gama(beta = 0.2000000 alfa = 70) >				2.243517
65 dl(2.243517	0.2000000	70	0.0000000E + 00
dl(2.743517	0.2000000	70	0.75567380E - 02

TABLE 1-continued

TABLE 1-continued

Design Parameters for CSSC Tube Fitting, (d1 = ΔL/R _e).				
	gama	beta	alfa	
dl(3.243517	0.2000000	70)= 0.1511347
dl(3.743517	0.2000000	70)= 0.2267021
dl(4.243517	0.2000000	70)= 0.3022694
dl(4.743517	0.2000000	70)= 0.3778368
dl(5.243517	0.2000000	70)= 0.4534041
dl(5.743517	0.2000000	70)= 0.5289715
dl(6.243517	0.2000000	70)= 0.6045388
dl(6.743517	0.2000000	70)= 0.6801062
dl(7.243517	0.2000000	70)= 0.7556735
gama(beta = 0.2000000			alfa = 75) >	4.172484
dl(4.172484	0.2000000	75)= 0.0000000E + 00
dl(4.672484	0.2000000	75)= 3.0446989E - 02
dl(5.172484	0.2000000	75)= 6.0893979E - 02
dl(5.672484	0.2000000	75)= 9.1340967E - 02
dl(6.172484	0.2000000	75)= 0.1217880
dl(6.672484	0.2000000	75)= 0.1522349
dl(7.172484	0.2000000	75)= 0.1826819
dl(7.672484	0.2000000	75)= 0.2131289
dl(8.172484	0.2000000	75)= 0.2435759
dl(8.672484	0.2000000	75)= 0.2740229
dl(9.172484	0.2000000	75)= 0.3044699
gama(beta = 0.3000000			alfa = 5) >	1.003273
dl(1.003273	0.3000000	5)= 0.0000000E + 00
dl(1.503273	0.3000000	5)= 3.993970
dl(2.003273	0.3000000	5)= 7.987939
dl(2.503273	0.3000000	5)= 11.98191
dl(3.003273	0.3000000	5)= 15.97588
dl(3.503273	0.3000000	5)= 19.96985
dl(4.003273	0.3000000	5)= 23.96382
dl(4.503273	0.3000000	5)= 27.95779
dl(5.003273	0.3000000	5)= 31.95176
dl(5.503273	0.3000000	5)= 35.94573
dl(6.003273	0.3000000	5)= 39.93970
gama(beta = 0.3000000			alfa = 10) >	1.013210
dl(1.013210	0.3000000	10)= 0.0000000E + 00
dl(1.513210	0.3000000	10)= 1.971826
dl(2.013210	0.3000000	10)= 3.943652
dl(2.513210	0.3000000	10)= 5.915477
dl(3.013210	0.3000000	10)= 7.887302
dl(3.513210	0.3000000	10)= 9.859128
dl(4.013210	0.3000000	10)= 11.83095
dl(4.513210	0.3000000	10)= 13.80278
dl(5.013210	0.3000000	10)= 15.77460
dl(5.513210	0.3000000	10)= 17.74643
dl(6.013210	0.3000000	10)= 19.71825
gama(beta = 0.3000000			alfa = 15) >	1.030178
dl(1.030178	0.3000000	15)= 0.0000000E + 00
dl(1.530178	0.3000000	15)= 1.286470
dl(2.030178	0.3000000	15)= 2.572940
dl(2.530178	0.3000000	15)= 3.859410
dl(3.030178	0.3000000	15)= 5.145880
dl(3.530178	0.3000000	15)= 6.432350
dl(4.030178	0.3000000	15)= 7.718821
dl(4.530178	0.3000000	15)= 9.005290
dl(5.030178	0.3000000	15)= 10.29176
dl(5.530178	0.3000000	15)= 11.57823
dl(6.030178	0.3000000	15)= 12.86470
gama(beta = 0.3000000			alfa = 20) >	1.054860
dl(1.054860	0.3000000	20)= 0.0000000E + 00
dl(1.554860	0.3000000	20)= 0.9351683
dl(2.054860	0.3000000	20)= 1.870337
dl(2.554860	0.3000000	20)= 2.805505
dl(3.054860	0.3000000	20)= 3.740673
dl(3.554860	0.3000000	20)= 4.675841
dl(4.054860	0.3000000	20)= 5.611008
dl(4.554860	0.3000000	20)= 6.546177
dl(5.054860	0.3000000	20)= 7.481345
dl(5.554860	0.3000000	20)= 8.416512
dl(6.054860	0.3000000	20)= 9.351681
gama(beta = 0.3000000			alfa = 25) >	1.088374
dl(1.088374	0.3000000	25)= 0.0000000E + 00

Design Parameters for CSSC Tube Fitting, (d1 = ΔL/R _e).				
	gama	beta	alfa	
5 dl(1.588374	0.3000000	25)= 0.7173234
dl(2.088374	0.3000000	25)= 1.434647
dl(2.588374	0.3000000	25)= 2.151970
dl(3.088374	0.3000000	25)= 2.869293
dl(3.588374	0.3000000	25)= 3.586617
dl(4.088374	0.3000000	25)= 4.303940
10 dl(4.588374	0.3000000	25)= 5.021263
dl(5.088374	0.3000000	25)= 5.738586
dl(5.588374	0.3000000	25)= 6.455910
dl(6.088374	0.3000000	25)= 7.173233
gama(beta = 0.3000000			alfa = 30) >	1.132503
15 dl(1.132503	0.3000000	30)= 0.0000000E + 00
dl(1.632503	0.3000000	30)= 0.5660253
dl(2.132503	0.3000000	30)= 1.132051
dl(2.632503	0.3000000	30)= 1.698076
dl(3.132503	0.3000000	30)= 2.264102
dl(3.632503	0.3000000	30)= 2.830127
dl(4.132503	0.3000000	30)= 3.396153
20 dl(4.632503	0.3000000	30)= 3.962178
dl(5.132503	0.3000000	30)= 4.528203
dl(5.632503	0.3000000	30)= 5.094229
dl(6.132503	0.3000000	30)= 5.660254
gama(beta = 0.3000000			alfa = 35) >	1.190112
25 dl(1.190112	0.3000000	35)= 0.0000000E + 00
dl(1.690112	0.3000000	35)= 0.4525571
dl(2.190112	0.3000000	35)= 0.9051141
dl(2.690112	0.3000000	35)= 1.357671
dl(3.190112	0.3000000	35)= 1.810228
dl(3.690112	0.3000000	35)= 2.262785
30 dl(4.190112	0.3000000	35)= 2.715343
dl(4.690112	0.3000000	35)= 3.167900
dl(5.190112	0.3000000	35)= 3.620456
dl(5.690112	0.3000000	35)= 4.073013
dl(6.190112	0.3000000	35)= 4.525570
gama(beta = 0.3000000			alfa = 40) >	1.265968
35 dl(1.265968	0.3000000	40)= 0.0000000E + 00
dl(1.765968	0.3000000	40)= 0.3625183
dl(2.265968	0.3000000	40)= 0.7250366
dl(2.765968	0.3000000	40)= 1.087555
dl(3.265968	0.3000000	40)= 1.450073
dl(3.765968	0.3000000	40)= 1.812591
40 dl(4.265968	0.3000000	40)= 2.175110
dl(4.765968	0.3000000	40)= 2.537628
dl(5.265968	0.3000000	40)= 2.900146
dl(5.765968	0.3000000	40)= 3.262665
dl(6.265968	0.3000000	40)= 3.625183
gama(beta = 0.3000000			alfa = 45) >	1.368454
45 dl(1.368454	0.3000000	45)= 0.0000000E + 00
dl(1.868454	0.3000000	45)= 0.2878680
dl(2.368454	0.3000000	45)= 0.5757360
dl(2.868454	0.3000000	45)= 0.8636041
dl(3.368454	0.3000000	45)= 1.151472
50 dl(3.868454	0.3000000	45)= 1.439340
dl(4.368454	0.3000000	45)= 1.727208
dl(4.868454	0.3000000	45)= 2.015076
dl(5.368454	0.3000000	45)= 2.302944
dl(5.868454	0.3000000	45)= 2.590812
dl(6.368454	0.3000000	45)= 2.878680
gama(beta = 0.3000000			alfa = 50) >	1.513575
55 dl(1.513575	0.3000000	50)= 0.0000000E + 00
dl(2.013575	0.3000000	50)= 0.2237388
dl(2.513575	0.3000000	50)= 0.4474775
dl(3.013575	0.3000000	50)= 0.6712162
dl(3.513575	0.3000000	50)= 0.8949549
60 dl(4.013575	0.3000000	50)= 1.118694
dl(4.513575	0.3000000	50)= 1.342432
dl(5.013575	0.3000000	50)= 1.566171
dl(5.513575	0.3000000	50)= 1.789910
dl(6.013575	0.3000000	50)= 2.013649
dl(6.513575	0.3000000	50)= 2.237387
gama(beta = 0.3000000			alfa = 55) >	1.735820
65 dl(1.735820	0.3000000	55)= 0.0000000E + 00

TABLE 1-continued

TABLE 1-continued

Design Parameters for CSSC Tube Fitting, ($d1 = \Delta L/R\epsilon_p$).

	gama	beta	alfa	
dl(1.735820	0.3000000	55	= 0.0000000E + 00
dl(2.235820	0.3000000	55	= 0.1669876
dl(2.735820	0.3000000	55	= 0.3339752
dl(3.235820	0.3000000	55	= 0.5009628
dl(3.735820	0.3000000	55	= 0.6679505
dl(4.235820	0.3000000	55	= 0.8349380
dl(4.735820	0.3000000	55	= 1.001926
dl(5.235820	0.3000000	55	= 1.168913
dl(5.735820	0.3000000	55	= 1.335901
dl(6.235820	0.3000000	55	= 1.502888
dl(6.735820	0.3000000	55	= 1.669876
gama(beta = 0.3000000 alfa = 60) >				2.125000
gama beta alfa				
dl(2.125000	0.3000000	60	= 0.0000000E + 00
dl(2.625000	0.3000000	60	= 0.1154701
dl(3.125000	0.3000000	60	= 0.2309401
dl(3.625000	0.3000000	60	= 0.3464102
dl(4.125000	0.3000000	60	= 0.4618802
dl(4.625000	0.3000000	60	= 0.5773503
dl(5.125000	0.3000000	60	= 0.6928203
dl(5.625000	0.3000000	60	= 0.8082904
dl(6.125000	0.3000000	60	= 0.9237605
dl(6.625000	0.3000000	60	= 1.039231
dl(7.125000	0.3000000	60	= 1.154701
gama(beta = 0.3000000 alfa = 65) >				3.009636
gama beta alfa				
dl(3.009636	0.3000000	65	= 0.0000000E + 00
dl(3.509636	0.3000000	65	= 6.7647174E - 02
dl(4.009636	0.3000000	65	= 0.1352943
dl(4.509636	0.3000000	65	= 0.2029415
dl(5.009636	0.3000000	65	= 0.2705886
dl(5.509636	0.3000000	65	= 0.3382358
dl(6.009636	0.3000000	65	= 0.4058830
dl(6.509636	0.3000000	65	= 0.4735300
dl(7.009636	0.3000000	65	= 0.5411772
dl(7.509636	0.3000000	65	= 0.6088244
dl(8.009637	0.3000000	65	= 0.6764715
gama(beta = 0.3000000 alfa = 70) >				7.304273
gama beta alfa				
dl(7.304273	0.3000000	70	= 0.0000000E + 00
dl(7.804273	0.3000000	70	= 2.2358468E - 02
dl(8.304274	0.3000000	70	= 4.4716977E - 02
dl(8.804274	0.3000000	70	= 6.7075446E - 02
dl(9.304274	0.3000000	70	= 8.9433916E - 02
dl(9.804274	0.3000000	70	= 0.1117924
dl(10.30427	0.3000000	70	= 0.1341508
dl(10.80427	0.3000000	70	= 0.1565093
dl(11.30427	0.3000000	70	= 0.1788678
dl(11.80427	0.3000000	70	= 0.2012262
dl(12.30427	0.3000000	70	= 0.2235847
gama(beta = 0.4000000 alfa = 5) >				1.005096
gama beta alfa				
dl(1.005096	0.4000000	5	= 0.0000000E + 00
dl(1.505096	0.4000000	5	= 3.420284
dl(2.005096	0.4000000	5	= 6.840568
dl(2.505096	0.4000000	5	= 10.26085
dl(3.005096	0.4000000	5	= 13.68113
dl(3.505096	0.4000000	5	= 17.10142
dl(4.005096	0.4000000	5	= 20.52170
dl(4.505096	0.4000000	5	= 23.94199
dl(5.005096	0.4000000	5	= 27.36227
dl(5.505096	0.4000000	5	= 30.78255
dl(6.005096	0.4000000	5	= 34.20284
gama(beta = 0.4000000 alfa = 10) >				1.020625
gama beta alfa				
dl(1.020625	0.4000000	10	= 0.0000000E + 00
dl(1.520625	0.4000000	10	= 1.683887
dl(2.020625	0.4000000	10	= 3.367775
dl(2.520625	0.4000000	10	= 5.051661
dl(3.020625	0.4000000	10	= 6.735548
dl(3.520625	0.4000000	10	= 8.419435
dl(4.020625	0.4000000	10	= 10.10332
dl(4.520625	0.4000000	10	= 11.78721
dl(5.020625	0.4000000	10	= 13.47109
dl(5.520625	0.4000000	10	= 15.15498
dl(6.020625	0.4000000	10	= 16.83887
gama(beta = 0.4000000 alfa = 15) >				1.047347

Design Parameters for CSSC Tube Fitting, ($d1 = \Delta L/R\epsilon_p$).

	gama	beta	alfa	
dl(1.047347	0.4000000	15	= 0.0000000E + 00
dl(1.547347	0.4000000	15	= 1.093285
dl(2.047347	0.4000000	15	= 2.186569
dl(2.547347	0.4000000	15	= 3.279854
dl(3.047347	0.4000000	15	= 4.373139
dl(3.547347	0.4000000	15	= 5.466424
dl(4.047347	0.4000000	15	= 6.559709
dl(4.547347	0.4000000	15	= 7.652993
dl(5.047347	0.4000000	15	= 8.746278
dl(5.547347	0.4000000	15	= 9.839563
dl(6.047347	0.4000000	15	= 10.93285
gama(beta = 0.4000000 alfa = 20) >				1.086700
gama beta alfa				
dl(1.086700	0.4000000	20	= 0.0000000E + 00
dl(1.586700	0.4000000	20	= 0.7889779
dl(2.086700	0.4000000	20	= 1.577956
dl(2.586700	0.4000000	20	= 2.366934
dl(3.086700	0.4000000	20	= 3.155912
dl(3.586700	0.4000000	20	= 3.944890
dl(4.086699	0.4000000	20	= 4.733867
dl(4.586699	0.4000000	20	= 5.522845
dl(5.086699	0.4000000	20	= 6.311823
dl(5.586699	0.4000000	20	= 7.100801
dl(6.086699	0.4000000	20	= 7.889779
gama(beta = 0.4000000 alfa = 25) >				1.141105
gama beta alfa				
dl(1.141105	0.4000000	25	= 0.0000000E + 00
dl(1.641105	0.4000000	25	= 0.5990134
dl(2.141105	0.4000000	25	= 1.198027
dl(2.641105	0.4000000	25	= 1.797040
dl(3.141105	0.4000000	25	= 2.396053
dl(3.641105	0.4000000	25	= 2.995066
dl(4.141105	0.4000000	25	= 3.594079
dl(4.641105	0.4000000	25	= 4.193092
dl(5.141105	0.4000000	25	= 4.792106
dl(5.641105	0.4000000	25	= 5.391119
dl(6.141105	0.4000000	25	= 5.990132
gama(beta = 0.4000000 alfa = 30) >				1.214581
gama beta alfa				
dl(1.214581	0.4000000	30	= 0.0000000E + 00
dl(1.714581	0.4000000	30	= 0.4660254
dl(2.214581	0.4000000	30	= 0.9320508
dl(2.714581	0.4000000	30	= 1.398076
dl(3.214581	0.4000000	30	= 1.864102
dl(3.714581	0.4000000	30	= 2.330127
dl(4.214581	0.4000000	30	= 2.796153
dl(4.714581	0.4000000	30	= 3.262178
dl(5.214581	0.4000000	30	= 3.728203
dl(5.714581	0.4000000	30	= 4.194229
dl(6.214581	0.4000000	30	= 4.660254
gama(beta = 0.4000000 alfa = 35) >				1.313958
gama beta alfa				
dl(1.313958	0.4000000	35	= 0.0000000E + 00
dl(1.813958	0.4000000	35	= 0.3653848
dl(2.313958	0.4000000	35	= 0.7307695
dl(2.813958	0.4000000	35	= 1.096154
dl(3.313958	0.4000000	35	= 1.461539
dl(3.813958	0.4000000	35	= 1.826923
dl(4.313958	0.4000000	35	= 2.192308
dl(4.813958	0.4000000	35	= 2.557693
dl(5.313958	0.4000000	35	= 2.923077
dl(5.813958	0.4000000	35	= 3.288462
dl(6.313958	0.4000000	35	= 3.653847
gama(beta = 0.4000000 alfa = 40) >				1.451504
gama beta alfa				
dl(1.451504	0.4000000	40	= 0.0000000E + 00
dl(1.951504	0.4000000	40	= 0.2847320
dl(2.451504	0.4000000	40	= 0.5694641
dl(2.951504	0.4000000	40	= 0.8541961
dl(3.451504	0.4000000	40	= 1.138928
dl(3.951504	0.4000000	40	= 1.423660
dl(4.451504	0.4000000	40	= 1.708392
dl(4.951504	0.4000000	40	= 1.993124
dl(5.451504	0.4000000	40	= 2.277856
dl(5.951504	0.4000000	40	= 2.562588
dl(6.451504	0.4000000	40	= 2.847321

TABLE 1-continued

TABLE 1-continued

Design Parameters for CSSC Tube Fitting, ($d1 = \Delta L/R\epsilon_p$).

gama(beta = 0.4000000	alfa = 45) >	1.651239
gama	beta	alfa
dl(1.651239	0.4000000	45)= 0.0000000E + 00
dl(2.151239	0.4000000	45)= 0.2171572
dl(2.651239	0.4000000	45)= 0.4343146
dl(3.151239	0.4000000	45)= 0.6514719
dl(3.651239	0.4000000	45)= 0.8686291
dl(4.151239	0.4000000	45)= 1.085786
dl(4.651239	0.4000000	45)= 1.302943
dl(5.151239	0.4000000	45)= 1.520101
dl(5.651239	0.4000000	45)= 1.737258
dl(6.151239	0.4000000	45)= 1.954415
dl(6.651239	0.4000000	45)= 2.171573
gama(beta = 0.4000000	alfa = 50) >	1.966811
gama	beta	alfa
dl(1.966811	0.4000000	50)= 0.0000000E + 00
dl(2.466811	0.4000000	50)= 0.1584684
dl(2.966811	0.4000000	50)= 0.3169367
dl(3.466811	0.4000000	50)= 0.4754050
dl(3.966811	0.4000000	50)= 0.6338733
dl(4.466811	0.4000000	50)= 0.7923417
dl(4.966811	0.4000000	50)= 0.9508100
dl(5.466811	0.4000000	50)= 1.109279
dl(5.966811	0.4000000	50)= 1.267747
dl(6.466811	0.4000000	50)= 1.426215
dl(6.966811	0.4000000	50)= 1.584683
gama(beta = 0.4000000	alfa = 55) >	2.546316
gama	beta	alfa
dl(2.546316	0.4000000	55)= 0.0000000E + 00
dl(3.046316	0.4000000	55)= 0.1059489
dl(3.546316	0.4000000	55)= 0.2118977
dl(4.046316	0.4000000	55)= 0.3178467
dl(4.546316	0.4000000	55)= 0.4237956
dl(5.046316	0.4000000	55)= 0.5297443
dl(5.546316	0.4000000	55)= 0.6356933
dl(6.046316	0.4000000	55)= 0.7416422
dl(6.546316	0.4000000	55)= 0.8475911
dl(7.046316	0.4000000	55)= 0.9535400
dl(7.546316	0.4000000	55)= 1.059489
gama(beta = 0.4000000	alfa = 60) >	4.000001
gama	beta	alfa
dl(1.000848	0.4000000	5)= 0.0000000E + 00
dl(4.500001	0.4000000	60)= 5.7735037E - 02
dl(5.000001	0.4000000	60)= 0.1154700
dl(5.500001	0.4000000	60)= 0.1732050
dl(6.000001	0.4000000	60)= 0.2309400
dl(6.500001	0.4000000	60)= 0.2886750
dl(7.000001	0.4000000	60)= 0.3464100
dl(7.500001	0.4000000	60)= 0.4041451
dl(8.000002	0.4000000	60)= 0.4618801
dl(8.500002	0.4000000	60)= 0.5196151
dl(9.000002	0.4000000	60)= 0.5773501
gama(beta = 0.4000000	alfa = 65) >	15.52622
gama	beta	alfa
dl(15.52622	0.4000000	65)= 0.0000000E + 00
dl(16.02622	0.4000000	65)= 1.2478273E - 02
dl(16.52622	0.4000000	65)= 2.4956491E - 02
dl(17.02622	0.4000000	65)= 3.7434764E - 02
dl(17.52622	0.4000000	65)= 4.9912982E - 02
dl(18.02622	0.4000000	65)= 6.2391199E - 02
dl(18.52622	0.4000000	65)= 7.4869417E - 02
dl(19.02622	0.4000000	65)= 8.7347694E - 02
dl(19.52622	0.4000000	65)= 9.9825911E - 02
dl(20.02622	0.4000000	65)= 0.1123041
dl(20.52622	0.4000000	65)= 0.1247824
gama(beta = 0.5000000	alfa = 5) >	1.007654
gama	beta	alfa
dl(1.007654	0.5000000	5)= 0.0000000E + 00
dl(1.507654	0.5000000	5)= 2.846598
dl(2.007654	0.5000000	5)= 5.693197
dl(2.507654	0.5000000	5)= 8.539796
dl(3.007654	0.5000000	5)= 11.38639
dl(3.507654	0.5000000	5)= 14.23299
dl(4.007654	0.5000000	5)= 17.07959
dl(4.507654	0.5000000	5)= 19.92619
dl(5.007654	0.5000000	5)= 22.77279

Design Parameters for CSSC Tube Fitting, ($d1 = \Delta L/R\epsilon_p$).

5	dl(5.507654	0.5000000	5)= 25.61938
	dl(6.007654	0.5000000	5)= 28.46598
	gama(beta = 0.5000000	alfa = 10) >	1.031099
	gama	beta	alfa
	dl(1.031099	0.5000000	5)= 0.0000000E + 00
	dl(1.531099	0.5000000	10)= 1.395948
	dl(2.031099	0.5000000	10)= 2.791897
10	dl(2.531099	0.5000000	10)= 4.187845
	dl(3.031099	0.5000000	10)= 5.583793
	dl(3.531099	0.5000000	10)= 6.979742
	dl(4.031099	0.5000000	10)= 8.375691
	dl(4.531099	0.5000000	10)= 9.771640
	dl(5.031099	0.5000000	10)= 11.16759
15	dl(5.531099	0.5000000	10)= 12.56354
	dl(6.031099	0.5000000	10)= 13.95948
	gama(beta = 0.5000000	alfa = 15) >	1.071886
	gama	beta	alfa
	dl(1.071886	0.5000000	15)= 0.0000000E + 00
	dl(1.571886	0.5000000	15)= 0.900998
20	dl(2.071886	0.5000000	15)= 1.800200
	dl(2.571886	0.5000000	15)= 2.700299
	dl(3.071886	0.5000000	15)= 3.600399
	dl(3.571886	0.5000000	15)= 4.500498
	dl(4.071886	0.5000000	15)= 5.400597
	dl(4.571886	0.5000000	15)= 6.300696
25	dl(5.071886	0.5000000	15)= 7.200796
	dl(5.571886	0.5000000	15)= 8.100896
	dl(6.071886	0.5000000	15)= 9.000996
	gama(beta = 0.5000000	alfa = 20) >	1.133022
	gama	beta	alfa
	dl(1.133022	0.5000000	20)= 0.0000000E + 00
	dl(1.633022	0.5000000	20)= 0.6427878
	dl(2.133022	0.5000000	20)= 1.285576
	dl(2.633022	0.5000000	20)= 1.928363
	dl(3.133022	0.5000000	20)= 2.571151
	dl(3.633022	0.5000000	20)= 3.213938
	dl(4.133022	0.5000000	20)= 3.856726
30	dl(4.633022	0.5000000	20)= 4.499513
	dl(5.133022	0.5000000	20)= 5.142301
	dl(5.633022	0.5000000	20)= 5.785089
	dl(6.133022	0.5000000	20)= 6.427876
	gama(beta = 0.5000000	alfa = 25) >	1.219792
	gama	beta	alfa
	dl(1.219792	0.5000000	25)= 0.0000000E + 00
	dl(1.719792	0.5000000	25)= 0.4807031
	dl(2.219792	0.5000000	25)= 0.9614062
	dl(2.719792	0.5000000	25)= 1.442109
	dl(3.219792	0.5000000	25)= 1.922812
	dl(3.719792	0.5000000	25)= 2.403515
	dl(4.219792	0.5000000	25)= 2.884219
	dl(4.719792	0.5000000	25)= 3.364922
35	dl(5.219792	0.5000000	25)= 3.845624
	dl(5.719792	0.5000000	25)= 4.326327
	dl(6.219792	0.5000000	25)= 4.807031
	gama(beta = 0.5000000	alfa = 30) >	1.341506
	gama	beta	alfa
	dl(1.341506	0.5000000	30)= 0.0000000E + 00
	dl(1.841506	0.5000000	30)= 0.3660255
	dl(2.341506	0.5000000	30)= 0.7320511
	dl(2.841506	0.5000000	30)= 1.098076
	dl(3.341506	0.5000000	30)= 1.464102
	dl(3.841506	0.5000000	30)= 1.830127
	dl(4.341506	0.5000000	30)= 2.196153
40	dl(4.841506	0.5000000	30)= 2.562178
	dl(5.341506	0.5000000	30)= 2.928203
	dl(5.841506	0.5000000	30)= 3.294229
	dl(6.341506	0.5000000	30)= 3.660254
	gama(beta = 0.5000000	alfa = 35) >	1.515412
	gama	beta	alfa
	dl(1.515412	0.5000000	35)= 0.0000000E + 00
	dl(2.015413	0.5000000	35)= 0.2782125
	dl(2.515413	0.5000000	35)= 0.5564247
	dl(3.015413	0.5000000	35)= 0.8346372
	dl(3.515413	0.5000000	35)= 1.112849
	dl(4.015412	0.5000000	35)= 1.391062
45	dl(4.515412	0.5000000	35)= 1.669274
	dl(5.015412	0.5000000	35)= 1.947486

TABLE 1-continued

Design Parameters for CSSC Tube Fitting, (d1 = ΔL/Rε _p).				
	gama	beta	alfa	
dl(5.515412	0.5000000	35)= 2.225699
dl(6.015412	0.5000000	35)= 2.503911
dl(6.515412	0.5000000	35)= 2.782123
gama(beta = 0.5000000 alfa = 40) >				1.776517
dl(1.776517	0.5000000	40)= 0.0000000E + 00
dl(2.276517	0.5000000	40)= 0.2069459
dl(2.776517	0.5000000	40)= 0.4138919
dl(3.276517	0.5000000	40)= 0.6208376
dl(3.776517	0.5000000	40)= 0.8277834
dl(4.276517	0.5000000	40)= 1.034729
dl(4.776517	0.5000000	40)= 1.241675
dl(5.276517	0.5000000	40)= 1.448621
dl(5.776517	0.5000000	40)= 1.655567
dl(6.276517	0.5000000	40)= 1.862513
dl(6.776517	0.5000000	40)= 2.069459
gama(beta = 0.5000000 alfa = 45) >				2.207107
dl(2.207107	0.5000000	45)= 0.0000000E + 00
dl(2.707107	0.5000000	45)= 0.1464467
dl(3.207107	0.5000000	45)= 0.2928933
dl(3.707107	0.5000000	45)= 0.4393399
dl(4.207107	0.5000000	45)= 0.5857866
dl(4.707107	0.5000000	45)= 0.7322332
dl(5.207107	0.5000000	45)= 0.8786799
dl(5.707107	0.5000000	45)= 1.025126
dl(6.207107	0.5000000	45)= 1.171573
dl(6.707107	0.5000000	45)= 1.318020
dl(7.207107	0.5000000	45)= 1.464466
gama(beta = 0.5000000 alfa = 50) >				3.054885
dl(3.054885	0.5000000	50)= 0.0000000E + 00
dl(3.554885	0.5000000	50)= 9.3198024E - 02
dl(4.054885	0.5000000	50)= 0.1863960
dl(4.554885	0.5000000	50)= 0.2795941
dl(5.054885	0.5000000	50)= 0.3727920
dl(5.554885	0.5000000	50)= 0.4659900
dl(6.054885	0.5000000	50)= 0.5591879
dl(6.554885	0.5000000	50)= 0.6523860
dl(7.054885	0.5000000	50)= 0.7455839
dl(7.554885	0.5000000	50)= 0.8387819
dl(8.054885	0.5000000	50)= 0.9319797
gama(beta = 0.5000000 alfa = 55) >				5.559950
dl(5.559950	0.5000000	55)= 0.0000000E + 00
dl(6.059950	0.5000000	55)= 4.4910204E - 02
dl(6.559950	0.5000000	55)= 8.9820325E - 02
dl(7.059950	0.5000000	55)= 0.1347304
dl(7.559950	0.5000000	55)= 0.1796406
dl(8.059951	0.5000000	55)= 0.2245508
dl(8.559951	0.5000000	55)= 0.2694609
dl(9.059951	0.5000000	55)= 0.3143710
dl(9.559951	0.5000000	55)= 0.3592812
dl(10.05995	0.5000000	55)= 0.4041913
dl(10.55995	0.5000000	55)= 0.4491014
gama(beta = 0.6000000 alfa = 5) >				1.011504
dl(1.011504	0.6000000	5)= 0.0000000E + 00
dl(1.511504	0.6000000	5)= 2.272913
dl(2.011504	0.6000000	5)= 4.545825
dl(2.511504	0.6000000	5)= 6.818738
dl(3.011504	0.6000000	5)= 9.091650
dl(3.511504	0.6000000	5)= 11.36456
dl(4.011504	0.6000000	5)= 13.63748
dl(4.511504	0.6000000	5)= 15.91039
dl(5.011504	0.6000000	5)= 18.18330
dl(5.511504	0.6000000	5)= 20.45621
dl(6.011504	0.6000000	5)= 22.72912
gama(beta = 0.6000000 alfa = 10) >				1.047016
dl(1.047016	0.6000000	10)= 0.0000000E + 00
dl(1.547016	0.6000000	10)= 1.108010
dl(2.047016	0.6000000	10)= 2.216020
dl(2.547016	0.6000000	10)= 3.324029
dl(3.047016	0.6000000	10)= 4.432040
dl(3.547016	0.6000000	10)= 5.540050
dl(4.047016	0.6000000	10)= 6.648058

TABLE 1-continued

Design Parameters for CSSC Tube Fitting, (d1 = ΔL/Rε _p).				
	gama	beta	alfa	
5 dl(4.547016	0.6000000	10)= 7.756068
dl(5.047016	0.6000000	10)= 8.864079
dl(5.547016	0.6000000	10)= 9.972089
dl(6.047016	0.6000000	10)= 11.08010
gama(beta = 0.6000000 alfa = 15) >				1.109838
10 dl(1.109838	0.6000000	15)= 0.0000000E + 00
dl(1.609838	0.6000000	15)= 0.7069143
dl(2.109838	0.6000000	15)= 1.413829
dl(2.609838	0.6000000	15)= 2.120744
dl(3.109838	0.6000000	15)= 2.827658
dl(3.609838	0.6000000	15)= 3.534573
15 dl(4.109838	0.6000000	15)= 4.241487
dl(4.609838	0.6000000	15)= 4.948401
dl(5.109838	0.6000000	15)= 5.655315
dl(5.609838	0.6000000	15)= 6.362230
dl(6.109838	0.6000000	15)= 7.069144
gama(beta = 0.6000000 alfa = 20) >				1.206618
20 dl(1.206618	0.6000000	20)= 0.0000000E + 00
dl(1.706618	0.6000000	20)= 0.4965974
dl(2.206618	0.6000000	20)= 0.9931949
dl(2.706618	0.6000000	20)= 1.489792
dl(3.206618	0.6000000	20)= 1.986390
25 dl(3.706618	0.6000000	20)= 2.482987
dl(4.206618	0.6000000	20)= 2.979584
dl(4.706618	0.6000000	20)= 3.476182
dl(5.206618	0.6000000	20)= 3.972780
dl(5.706618	0.6000000	20)= 4.469377
dl(6.206618	0.6000000	20)= 4.965974
gama(beta = 0.6000000 alfa = 25) >				1.349856
30 dl(1.349856	0.6000000	25)= 0.0000000E + 00
dl(1.849856	0.6000000	25)= 0.3623931
dl(2.349856	0.6000000	25)= 0.7247862
dl(2.849856	0.6000000	25)= 1.087179
dl(3.349856	0.6000000	25)= 1.449572
35 dl(3.849856	0.6000000	25)= 1.811965
dl(4.349856	0.6000000	25)= 2.174359
dl(4.849856	0.6000000	25)= 2.536751
dl(5.349856	0.6000000	25)= 2.899144
dl(5.849856	0.6000000	25)= 3.261538
dl(6.349856	0.6000000	25)= 3.623930
gama(beta = 0.6000000 alfa = 30) >				1.563856
40 dl(1.563856	0.6000000	30)= 0.0000000E + 00
dl(2.063856	0.6000000	30)= 0.2660254
dl(2.563856	0.6000000	30)= 0.5320508
dl(3.063856	0.6000000	30)= 0.7980763
dl(3.563856	0.6000000	30)= 1.064102
45 dl(4.063856	0.6000000	30)= 1.330127
dl(4.563856	0.6000000	30)= 1.596153
dl(5.063856	0.6000000	30)= 1.862178
dl(5.563856	0.6000000	30)= 2.128203
dl(6.063856	0.6000000	30)= 2.394229
dl(6.563856	0.6000000	30)= 2.660254
gama(beta = 0.6000000 alfa = 35) >				1.900716
50 dl(1.900716	0.6000000	35)= 0.0000000E + 00
dl(2.400717	0.6000000	35)= 0.1910401
dl(2.900717	0.6000000	35)= 0.3820800
dl(3.400717	0.6000000	35)= 0.5731202
55 dl(3.900717	0.6000000	35)= 0.7641601
dl(4.400716	0.6000000	35)= 0.9552000
dl(4.900716	0.6000000	35)= 1.146240
dl(5.400716	0.6000000	35)= 1.337280
dl(5.900716	0.6000000	35)= 1.528320
dl(6.400716	0.6000000	35)= 1.719360
dl(6.900716	0.6000000	35)= 1.910400
gama(beta = 0.6000000 alfa = 40) >				2.493007
60 dl(2.493007	0.6000000	40)= 0.0000000E + 00
dl(2.993007	0.6000000	40)= 0.1291597
dl(3.493007	0.6000000	40)= 0.2583195
dl(3.993007	0.6000000	40)= 0.3874791
65 dl(4.493007	0.6000000	40)= 0.5166388
dl(4.993007	0.6000000	40)= 0.6457986

TABLE 1-continued

TABLE 1-continued

Design Parameters for CSSC Tube Fitting, (d1 = ΔL/R _{cp}).			
	gama	beta	alfa
d1(5.493007	0.6000000	40
d1(5.993007	0.6600000	40
d1(6.493007	0.6000000	40
d1(6.993007	0.6000000	40
d1(7.493007	0.6000000	40
gama(beta = 0.6000000 alfa = 45) > 3.800942			
d1(3.800942	0.6000000	45
d1(4.300942	0.6000000	45
d1(4.800942	0.6000000	45
d1(5.300942	0.6000000	45
d1(5.800942	0.6000000	45
d1(6.300942	0.6000000	45
d1(6.800942	0.6000000	45
d1(7.300942	0.6000000	45
d1(7.800942	0.6000000	45
d1(8.300942	0.6000000	45
d1(8.800942	0.6000000	45
gama(beta = 0.6000000 alfa = 50) > 9.228890			
d1(9.228890	0.6000000	50
d1(9.728890	0.6000000	50
d1(10.22889	0.6000000	50
d1(10.72889	0.6000000	50
d1(11.22889	0.6000000	50
d1(11.72889	0.6000000	50
d1(12.22889	0.6000000	50
d1(12.72889	0.6000000	50
d1(13.22889	0.6000000	50
d1(13.72889	0.6000000	50
d1(14.22889	0.6000000	50
gama(beta = 0.7000000 alfa = 5) > 1.017952			
d1(1.017952	0.7000000	5
d1(1.517952	0.7000000	5
d1(2.017952	0.7000000	5
d1(2.517952	0.7000000	5
d1(3.017952	0.7000000	5
d1(3.517952	0.7000000	5
d1(4.017952	0.7000000	5
d1(4.517952	0.7000000	5
d1(5.017952	0.7000000	5
d1(5.517952	0.7000000	5
d1(6.017952	0.7000000	5
gama(beta = 0.7000000 alfa = 10) > 1.074112			
d1(1.074112	0.7000000	10
d1(1.574112	0.7000000	10
d1(2.074112	0.7000000	10
d1(2.574112	0.7000000	10
d1(3.074112	0.7000000	10
d1(3.574112	0.7000000	10
d1(4.074112	0.7000000	10
d1(4.574112	0.7000000	10
d1(5.074112	0.7000000	10
d1(5.574112	0.7000000	10
d1(6.074112	0.7000000	10
gama(beta = 0.7000000 alfa = 15) > 1.176332			
d1(1.176332	0.7000000	15
d1(1.676332	0.7000000	15
d1(2.176332	0.7000000	15
d1(2.676332	0.7000000	15
d1(3.176332	0.7000000	15
d1(3.676332	0.7000000	15
d1(4.176332	0.7000000	15
d1(4.676332	0.7000000	15
d1(5.176332	0.7000000	15
d1(5.676332	0.7000000	15
d1(6.176332	0.7000000	15
gama(beta = 0.7000000 alfa = 20) > 1.341623			
d1(1.341623	0.7000000	20
d1(1.841623	0.7000000	20
d1(2.341623	0.7000000	20
d1(2.841623	0.7000000	20
d1(3.341623	0.7000000	20

Design Parameters for CSSC Tube Fitting, (d1 = ΔL/R _{cp}).			
	gama	beta	alfa
d1(3.841623	0.7000000	20
d1(4.341623	0.7000000	20
d1(4.841623	0.7000000	20
d1(5.341623	0.7000000	20
d1(5.841623	0.7000000	20
d1(6.341623	0.7000000	20
gama(beta = 0.7000000 alfa = 25) > 1.606009			
d1(1.606009	0.7000000	25
d1(2.106009	0.7000000	25
d1(2.606009	0.7000000	25
d1(3.106009	0.7000000	25
d1(3.606009	0.7000000	25
d1(4.106009	0.7000000	25
d1(4.606009	0.7000000	25
d1(5.106009	0.7000000	25
d1(5.606009	0.7000000	25
d1(6.106009	0.7000000	25
d1(6.606009	0.7000000	25
gama(beta = 0.7000000 alfa = 30) > 2.054056			
d1(2.054056	0.7000000	30
d1(2.554056	0.7000000	30
d1(3.054056	0.7000000	30
d1(3.554056	0.7000000	30
d1(4.054056	0.7000000	30
d1(4.554056	0.7000000	30
d1(5.054056	0.7000000	30
d1(5.554056	0.7000000	30
d1(6.054056	0.7000000	30
d1(6.554056	0.7000000	30
d1(7.054056	0.7000000	30
gama(beta = 0.7000000 alfa = 35) > 2.932765			
d1(2.932765	0.7000000	35
d1(3.432765	0.7000000	35
d1(3.932765	0.7000000	35
d1(4.432765	0.7000000	35
d1(4.932765	0.7000000	35
d1(5.432765	0.7000000	35
d1(5.932765	0.7000000	35
d1(6.432765	0.7000000	35
d1(6.932765	0.7000000	35
d1(7.432765	0.7000000	35
d1(7.932765	0.7000000	35
gama(beta = 0.7000000 alfa = 40) > 5.379220			
d1(5.379220	0.7000000	40
d1(5.879220	0.7000000	40
d1(6.379220	0.7000000	40
d1(6.879220	0.7000000	40
d1(7.379220	0.7000000	40
d1(7.879220	0.7000000	40
d1(8.379220	0.7000000	40
d1(8.879220	0.7000000	40
d1(9.379220	0.7000000	40
d1(9.879220	0.7000000	40
d1(10.37922	0.7000000	40
gama(beta = 0.7000000 alfa = 45) > 50.24860			
d1(50.24860	0.7000000	45
d1(50.74860	0.7000000	45
d1(51.24860	0.7000000	45
d1(51.74860	0.7000000	45
d1(52.24860	0.7000000	45
d1(52.74860	0.7000000	45
d1(53.24860	0.7000000	45
d1(53.74860	0.7000000	45
d1(54.24860	0.7000000	45
d1(54.74860	0.7000000	45
d1(55.24860	0.7000000	45
gama(beta = 0.8000000 alfa = 5) > 1.030974			
d1(1.030974	0.8000000	5
d1(1.530974	0.8000000	5
d1(2.030974	0.8000000	5
d1(2.530974	0.8000000	5

TABLE 1-continued

Design Parameters for CSSC Tube Fitting, ($d1 = \Delta L/R\epsilon_p$).					
	gama	beta	alfa		
dl(3.030974	0.8000000	5	≧ 4.502163	
dl(3.530974	0.8000000	5	≧ 5.627705	
dl(4.030974	0.8000000	5	≧ 6.753245	
dl(4.530974	0.8000000	5	≧ 7.878787	
dl(5.030974	0.8000000	5	≧ 9.004327	
dl(5.530974	0.8000000	5	≧ 10.12987	
dl(6.030974	0.8000000	5	≧ 11.25541	
gama(beta = 0.8000000 alfa = 10) >				1.130530	
gama				beta	alfa
dl(1.130530	0.8000000	10	≧ 0.0000000E + 00	
dl(1.630530	0.8000000	10	≧ 0.5321329	
dl(2.130530	0.8000000	10	≧ 1.064265	
dl(2.630530	0.8000000	10	≧ 1.596398	
dl(3.130530	0.8000000	10	≧ 2.128531	
dl(3.630530	0.8000000	10	≧ 2.660663	
dl(4.130530	0.8000000	10	≧ 3.192796	
dl(4.630530	0.8000000	10	≧ 3.724929	
dl(5.130530	0.8000000	10	≧ 4.257061	
dl(5.630530	0.8000000	10	≧ 4.789194	
dl(6.130530	0.8000000	10	≧ 5.321326	
gama(beta = 0.8000000 alfa = 15) >				1.322975	
gama				beta	alfa
dl(1.322975	0.8000000	15	≧ 0.0000000E + 00	
dl(1.822975	0.8000000	15	≧ 0.3205443	
dl(2.322975	0.8000000	15	≧ 0.6410881	
dl(2.822975	0.8000000	15	≧ 0.9616324	
dl(3.322975	0.8000000	15	≧ 1.282176	
dl(3.822975	0.8000000	15	≧ 1.602720	
dl(4.322975	0.8000000	15	≧ 1.923264	
dl(4.822975	0.8000000	15	≧ 2.243809	
dl(5.322975	0.8000000	15	≧ 2.564352	
dl(5.822975	0.8000000	15	≧ 2.884897	
dl(6.322975	0.8000000	15	≧ 3.205441	
gama(beta = 0.8000000 alfa = 20) >				1.669916	
gama				beta	alfa
dl(1.669916	0.8000000	20	≧ 0.0000000E + 00	
dl(2.169916	0.8000000	20	≧ 0.2042170	
dl(2.669916	0.8000000	20	≧ 0.4084340	
dl(3.169916	0.8000000	20	≧ 0.6126506	
dl(3.669916	0.8000000	20	≧ 0.8168676	
dl(4.169916	0.8000000	20	≧ 1.021085	
dl(4.669916	0.8000000	20	≧ 1.225302	
dl(5.169916	0.8000000	20	≧ 1.429518	
dl(5.669916	0.8000000	20	≧ 1.633735	
dl(6.169916	0.8000000	20	≧ 1.837952	
dl(6.669916	0.8000000	20	≧ 2.042169	
gama(beta = 0.8000000 alfa = 25) >				2.344067	
gama				beta	alfa
dl(2.344067	0.8000000	25	≧ 0.0000000E + 00	
dl(2.844067	0.8000000	25	≧ 0.1257728	
dl(3.344067	0.8000000	25	≧ 0.2515459	
dl(3.844067	0.8000000	25	≧ 0.3773187	
dl(4.344068	0.8000000	25	≧ 0.5030918	
dl(4.844068	0.8000000	25	≧ 0.6288645	
dl(5.344068	0.8000000	25	≧ 0.7546374	
dl(5.844068	0.8000000	25	≧ 0.8804101	
dl(6.344068	0.8000000	25	≧ 1.006183	
dl(6.844068	0.8000000	25	≧ 1.131956	
dl(7.344068	0.8000000	25	≧ 1.257729	
gama(beta = 0.8000000 alfa = 30) >				4.029140	
gama				beta	alfa
dl(4.029140	0.8000000	30	≧ 0.0000000E + 00	
dl(4.529140	0.8000000	30	≧ 6.6025421E - 02	
dl(5.029140	0.8000000	30	≧ 0.1320508	
dl(5.529140	0.8000000	30	≧ 0.1980761	
dl(6.029140	0.8000000	30	≧ 0.2641015	
dl(6.529140	0.8000000	30	≧ 0.3301269	
dl(7.029140	0.8000000	30	≧ 0.3961523	
dl(7.529140	0.8000000	30	≧ 0.4621775	
dl(8.029140	0.8000000	30	≧ 0.5282030	
dl(8.529140	0.8000000	30	≧ 0.5942284	
dl(9.029140	0.8000000	30	≧ 0.6602538	
gama(beta = 0.8000000 alfa = 35) >				14.74223	
gama				beta	alfa
dl(14.74223	0.8000000	35	≧ 0.0000000E + 00	
dl(15.24223	0.8000000	35	≧ 1.6695250E - 02	
dl(15.74223	0.8000000	35	≧ 3.3390671E - 02	

TABLE 1-continued

Design Parameters for CSSC Tube Fitting, ($d1 = \Delta L/R\epsilon_p$).					
	gama	beta	alfa		
5 dl(16.24223	0.8000000	35	≧ 5.0085921E - 02	
dl(16.74223	0.8000000	35	≧ 6.6781171E - 02	
dl(17.24223	0.8000000	35	≧ 8.3476588E - 02	
dl(17.74223	0.8000000	35	≧ 0.1001718	
dl(18.24223	0.8000000	35	≧ 0.1168671	
dl(18.74223	0.8000000	35	≧ 0.1335623	
10 dl(19.24223	0.8000000	35	≧ 0.1502578	
dl(19.74223	0.8000000	35	≧ 0.1669530	
gama(beta = 0.9000000 alfa = 5) >				1.071069	
gama				beta	alfa
dl(1.071069	0.9000000	5	≧ 0.0000000E + 00	
dl(1.571069	0.9000000	5	≧ 0.5518552	
15 dl(2.071069	0.9000000	5	≧ 1.103712	
dl(2.571069	0.9000000	5	≧ 1.655567	
dl(3.071069	0.9000000	5	≧ 2.207422	
dl(3.571069	0.9000000	5	≧ 2.759278	
dl(4.071069	0.9000000	5	≧ 3.311134	
dl(4.571069	0.9000000	5	≧ 3.862989	
20 dl(5.071069	0.9000000	5	≧ 4.414845	
dl(5.571069	0.9000000	5	≧ 4.966701	
dl(6.071069	0.9000000	5	≧ 5.518556	
gama(beta = 0.9000000 alfa = 10) >				1.319999	
gama				beta	alfa
dl(1.319999	0.9000000	10	≧ 0.0000000E + 00	
dl(1.819999	0.9000000	10	≧ 0.2441943	
25 dl(2.319999	0.9000000	10	≧ 0.4883885	
dl(2.819999	0.9000000	10	≧ 0.7325828	
dl(3.319999	0.9000000	10	≧ 0.9767771	
dl(3.819999	0.9000000	10	≧ 1.220971	
dl(4.319999	0.9000000	10	≧ 1.465166	
30 dl(4.819999	0.9000000	10	≧ 1.709360	
dl(5.319999	0.9000000	10	≧ 1.953554	
dl(5.819999	0.9000000	10	≧ 2.197748	
dl(6.319999	0.9000000	10	≧ 2.441943	
gama(beta = 0.9000000 alfa = 15) >				1.914492	
gama				beta	alfa
dl(1.914492	0.9000000	15	≧ 0.0000000E + 00	
35 dl(2.414492	0.9000000	15	≧ 0.1273588	
dl(2.914492	0.9000000	15	≧ 0.2547180	
dl(3.414492	0.9000000	15	≧ 0.3820768	
dl(3.914492	0.9000000	15	≧ 0.5094356	
dl(4.414492	0.9000000	15	≧ 0.6367944	
40 dl(4.914492	0.9000000	15	≧ 0.7641537	
dl(5.414492	0.9000000	15	≧ 0.8915125	
dl(5.914492	0.9000000	15	≧ 1.018871	
dl(6.414492	0.9000000	15	≧ 1.146230	
dl(6.914492	0.9000000	15	≧ 1.273589	
gama(beta = 0.9000000 alfa = 20) >				3.652381	
gama				beta	alfa
45 dl(3.652381	0.9000000	20	≧ 0.0000000E + 00	
dl(4.152381	0.9000000	20	≧ 5.8026921E - 02	
dl(4.652381	0.9000000	20	≧ 0.1160535	
dl(5.152381	0.9000000	20	≧ 0.1740804	
dl(5.652381	0.9000000	20	≧ 0.2321070	
50 dl(6.152381	0.9000000	20	≧ 0.2901340	
dl(6.652381	0.9000000	20	≧ 0.3481605	
dl(7.152381	0.9000000	20	≧ 0.4061875	
dl(7.652381	0.9000000	20	≧ 0.4642141	
dl(8.152381	0.9000000	20	≧ 0.5222410	
dl(8.652381	0.9000000	20	≧ 0.5802675	
gama(beta = 0.9000000 alfa = 25) >				26.48351	
gama				beta	alfa
dl(26.48351	0.9000000	25	≧ 0.0000000E + 00	
dl(26.98351	0.9000000	25	≧ 7.4627930E - 03	
dl(27.48351	0.9000000	25	≧ 1.4925586E - 02	
dl(27.98351	0.9000000	25	≧ 2.2388378E - 02	
60 dl(28.48351	0.9000000	25	≧ 2.9851172E - 02	
dl(28.98351	0.9000000	25	≧ 3.7313964E - 02	
dl(29.48351	0.9000000	25	≧ 4.4776756E - 02	
dl(29.98351	0.9000000	25	≧ 5.2239552E - 02	
dl(30.48351	0.9000000	25	≧ 5.9702344E - 02	
dl(30.98351	0.9000000	25	≧ 6.7165136E - 02	
65 dl(31.48351	0.9000000	25	≧ 7.4627928E - 02 "Z	

I claim:

1. A method of creating a seal that is effective across a range of temperatures, including cryogenic temperatures, comprising the steps of:

- a) selecting a sealing spacer having a desired coefficient of thermal expansion and tube ends having different coefficients of thermal expansion therefrom, said spacer and said tube ends also having shapes complementary to each other such that when said tube ends are brought into contact with said spacer, a sealed sloped engagement results yielding sloped-surface sealing; and
- b) placing said spacer in contact with said tube ends such that a sealed sloped engagement yielding sloped-surface sealing is accomplished that maintains the seal across a range of various temperatures, including cryogenic temperatures.

2. The method according to claim 1, wherein said sealing spacer is placed in contact with said tube ends by using a housing nut.

3. The method according to claim 2, wherein said housing nut, during cooling, contracts and thereby forces said tube ends toward each other, thereby maintaining the seal various temperatures, including cryogenic temperatures.

4. The method according to claim 3, wherein said housing nut has a larger coefficient of thermal expansion than said tube ends.

5. A method of joining tube ends to provide an effective seal across a range of temperatures, including cryogenic temperatures, wherein said tube ends each have a sloped contact surface, said method comprising the steps of

- a) selecting a sealing spacer having a larger coefficient of thermal expansion than said tube ends, and a shape complementary thereto; and
- b) placing said sealing spacer in contact with each said sloped contact surface so that during cooling, as said sealing spacer contracts, a sealed engagement with each of said sloped contact surfaces yielding sloped-surface sealing is maintained.

6. The method according to claim 5, wherein each of said sloped contact surfaces is on an outer portion of each of said tube ends.

7. The method according to claim 6, wherein said sealing spacer is placed in contact with said sloped contact surfaces by using a housing nut.

8. The method according to claim 7, wherein said housing nut, during cooling, contracts and thereby forces said tube ends toward each other, thereby maintaining the formation and maintenance of a leak-free seal at various temperatures, including cryogenic temperatures.

9. The method according to claim 8, wherein said housing nut has a larger coefficient of thermal expansion than said tube ends.

10. The method according to claim 5, wherein said sealing spacer is placed in contact with said sloped contact surfaces by using a housing nut.

11. The method according to claim 10, wherein said housing nut, during cooling, contracts and thereby forces said tube ends toward each other, thereby maintaining the formation and maintenance of a leak-free seal at various temperatures, including cryogenic temperatures.

12. The method according to claim 11, wherein said housing nut has a larger coefficient of thermal expansion than said tube ends.

13. A cryogenic tube seal comprising a first coupling member having a first sloped contact surface on an outer portion of said member; a second coupling member having a second sloped contact surface on an outer portion of said member; and sealing means for establishing and maintaining sloped-surface sealing between said coupling members at cryogenic temperatures at least as low as about 77K without resulting in inelastic deformation of either of said sloped contact surfaces or said sealing means.

14. The cryogenic tube seal, according to claim 13, wherein said sealing means comprises a sealing spacer having a greater coefficient of thermal expansion than each of said coupling members, wherein said sealing spacer contacts said first contact surface and said second contact surface, and wherein said sealing means also comprises a housing nut selectively engaged with said first coupling member and said second coupling member, wherein said housing nut has a greater coefficient of thermal expansion than each of said coupling members.

15. The seal, according to claim 14, wherein said sealing spacer is an O-ring spacer.

* * * * *

UNITED STATES PATENT AND TRADEMARK OFFICE
CERTIFICATE OF CORRECTION

5,628,517

PATENT NO. :

DATED : May 13, 1997

INVENTOR(S) :

Hall *et al.*

It is certified that error appears in the above-identified patent and that said Letters Patent is hereby corrected as shown below:

Column 1: line 40: "ting" should read --ring--; line 41: "ting" should read --ring--.

Column 3: line 48: "a housing nut.." should read --a housing nut.--

Column 5: line 17: "tube end :12 into" should read --tube end 22 into--;

line 54: " $[\alpha + O \tan^{-1} (...]$ " should read -- $[\alpha + \tan^{-1} (...]$ --.

Column 6: line 46: "and $\Delta\tau' = \Delta L' \tan\alpha$," should read --and $\Delta\tau' = \Delta L' \tan\alpha$ --;

line 54: "where $\Delta r = r_1 r_2$ " should read --where $\Delta r = r_1 - r_2$;

lines 65&55: "where ϵ and ϵ_p are" should read --where ϵ_o and ϵ_p are--.

Column 7: line 6: "Let $\gamma = \epsilon_o/\epsilon_p$, and $\beta = r_1/R$," should read --Let $\gamma = \epsilon_o/\epsilon_p$, and $\beta = r_1/R$ --.

Column 27: line 23: "the seal various" should read --the seal at various--.

Signed and Sealed this

Nineteenth Day of August, 1997

Attest:



BRUCE LEHMAN

Attesting Officer

Commissioner of Patents and Trademarks