

Workshop on Jet Exhaust Noise Reduction for Tactical Aircraft - NASA Perspective

Dennis L. Huff
NASA Glenn Research Center

and

Brenda S. Henderson
NASA Langley Research Center

Jet noise from supersonic, high performance aircraft is a significant problem for takeoff and landing operations near air bases and aircraft carriers. As newer aircraft with higher thrust and performance are introduced, the noise tends to increase due to higher jet exhaust velocities. Jet noise has been a subject of research for over 55 years. Commercial subsonic aircraft benefit from changes to the engine cycle that reduce the exhaust velocities and result in significant noise reduction. Most of the research programs over the past few decades have concentrated on commercial aircraft. Progress has been made by introducing new engines with design features that reduce the noise.

NASA has recently started a new program called “Fundamental Aeronautics” where three projects (subsonic fixed wing, subsonic rotary wing, and supersonics) address aircraft noise. For the supersonics project, a primary goal is to understand the underlying physics associated with jet noise so that improved noise prediction tools and noise reduction methods can be developed for a wide range of applications. Highlights from the supersonics project are presented including prediction methods for broadband shock noise, flow measurement methods, and noise reduction methods.

Realistic expectations are presented based on past history that indicates significant jet noise reduction cannot be achieved without major changes to the engine cycle. NASA’s past experience shows a few EPNdB (effective perceived noise level in decibels) can be achieved using low noise design features such as chevron nozzles. Minimal thrust loss can be expected with these nozzles (< 0.5%) and they may be retrofitted on existing engines. In the long term, it is desirable to use variable cycle engines that can be optimized for lower jet noise during takeoff operations and higher thrust for operational performance. It is also suggested that noise experts be included early in the design process for engine nozzle systems to participate in decisions that may impact the jet noise.

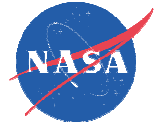

Workshop on Jet Exhaust Noise Reduction for Tactical Aircraft - NASA Perspective

November 27, 2007

***by* Dennis L. Huff *and* Brenda S. Henderson**

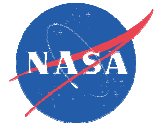

History Shows The Problem Is Difficult To Solve

Good News: High performance military aircraft noise is dominated by a single source called “jet noise” (commercial aircraft have multiple sources)

Bad News: This source has been the subject of research for the past 55 years and progress has been incremental.

- Major jet noise reduction has been achieved through changing the cycle of the engine to reduce the jet exit velocity.
- Smaller reductions (a few EPNdB) have been achieved using suppression devices like mixing enhancement, acoustic liners.
- Significant jet noise reduction without any performance loss is probably not possible!

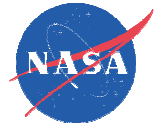

Aircraft Noise Trends

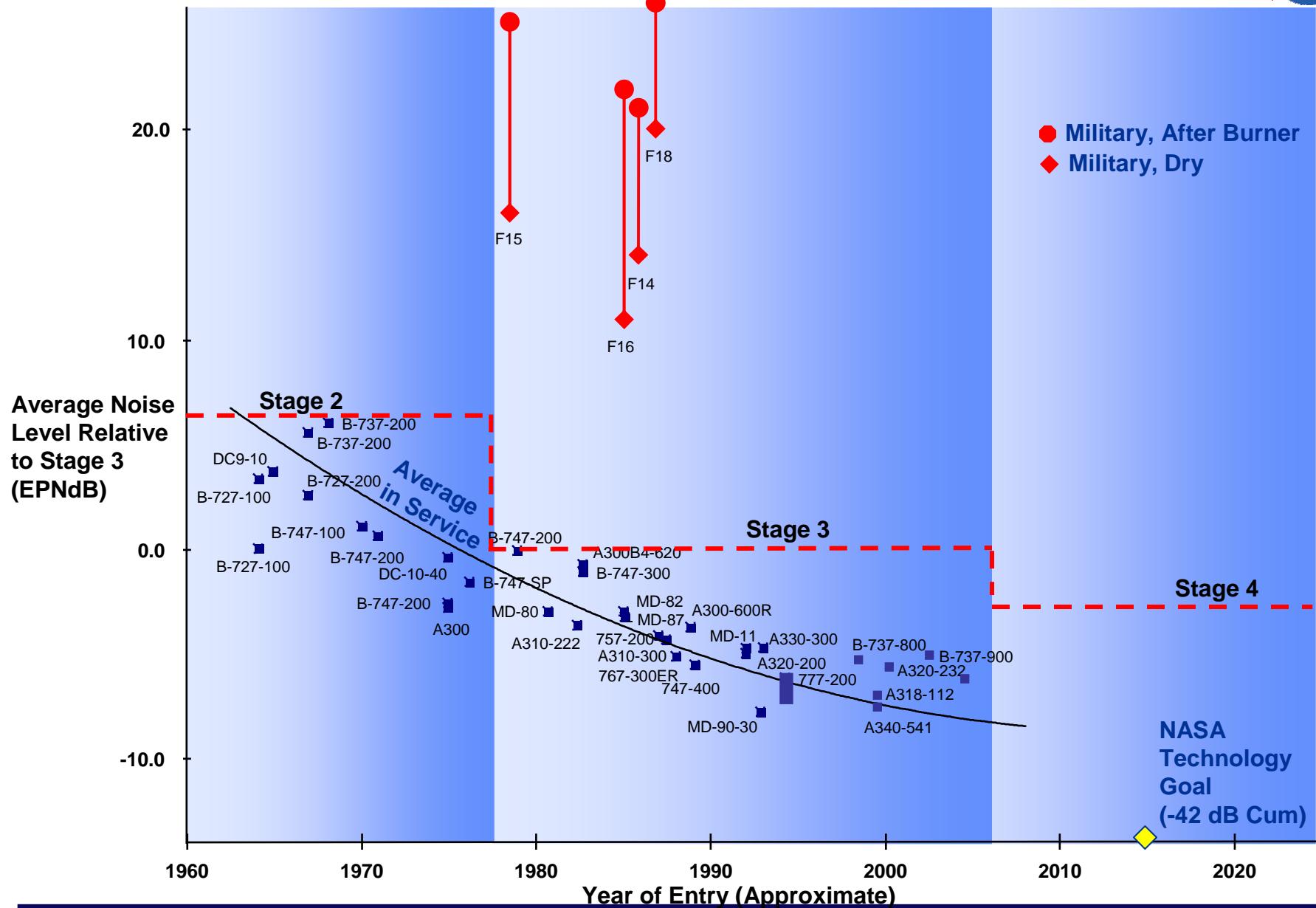

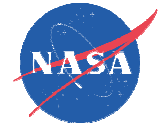

Supersonic Jet Noise Sources

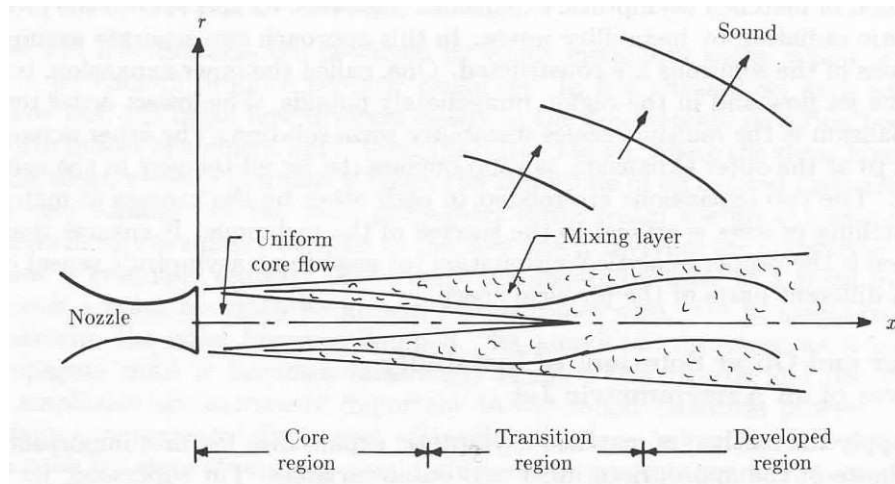

- Turbulent Jet Mixing
- Broadband Shock Noise
- Screech

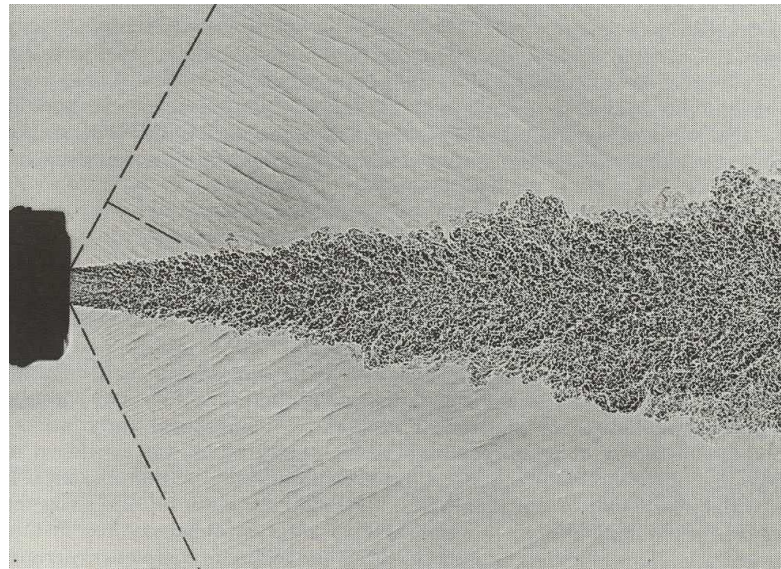

Tam, C.K.W., Directional Acoustic Radiation From a Supersonic Jet Generated by Shear Layer Instability, *Journal of Fluid Mechanics*, Vol. 46, Pt. 4, Apr. 27, 1971, pp. 757-768.

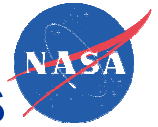

Recent NASA Noise Reduction Research Programs

High Speed Research (HSR) Program

- 1990 - 1999
- Focused research on specific engine & mission (mixed-flow turbofan)

Advanced Subsonic Technology (AST) Noise Reduction Program

- 1993 - 2001
- Applied research for commercial turbofan engines with emphasis on fan and jet noise

Quiet Aircraft Technology (QAT) Project

- 2001 - 2005
- Research for new subsonic commercial engines to meet aggressive 10 dB and 20 dB noise reduction goals (relative to 1997 best-in-fleet technology)

Fundamental Aeronautics (FA) Program

- 2006 - present
- Supersonic & subsonic fundamental research aimed at understanding noise sources, also working on rotorcraft noise
- Emphasis on Multi-Disciplinary Design and Optimization (MDAO) tool development

Noise research for subsonic applications outpaces supersonic work by a large margin!

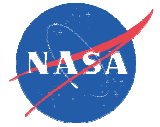

NASA Lear 25 Flight Demonstration of Turbojet Noise Reduction

Objectives

- Confirm model scale test results
- Determine flight effects of installed chevron nozzle
- Investigate chevron nozzles for supersonic jet exit velocities

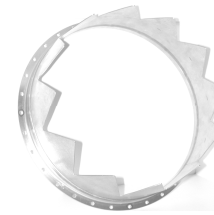

6 and 12 Point Chevron Nozzles

Approach

- Completed model scale acoustic and performance tests
- Demonstrated 3 EPNdB jet noise reduction with 0.5% thrust loss
- Flight test in March 2001 on Learjet 25 with CJ610-6 engines showed ~2 EPNdB jet noise reduction



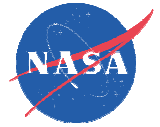

NASA Lear 25 Flight Demonstration of Turbojet Noise Reduction



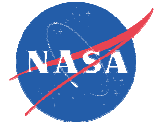

NASA's Fundamental Aeronautics Program

Overcome today's national challenges in air transportation

- Invest in fundamental core competencies
- Involve external aeronautics community to support best technological talent and ideas
- Widely disseminate research results

Four projects

- Subsonic Fixed Wing
- Subsonic Rotary Wing
- Supersonics
- Hypersonics

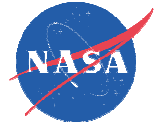

Supersonics Project

Major technical challenges

- Efficiency
- Environment
 - **Airport noise**
 - Sonic boom
 - High-altitude emissions
- Performance
- Entry descent and landing
- Multidisciplinary design, analysis, and optimization

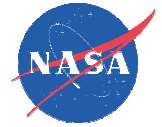

Airport Noise - Technical Challenge

- Enable vehicles capable of economical supersonic flight to be acoustically compatible with existing fleet around airports.
- Envision **noise reduction technologies** which break current overall noise trends of noise vs specific thrust.
- Create design and analysis **tools** to evaluate and optimize noise along with other aircraft performance measures.

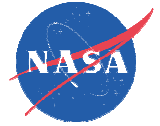

Airport Noise - Technical Approach

- **Elements**
 - Prediction
 - Diagnostics
 - Engineering
- **Significant interaction between elements**
- **Internal and external NASA Research Announcement (NRA) research folded into program to meet project objectives**



Prediction

- **Statistical modeling in supersonic jet noise**
 - **Mixing noise, shock noise, and Mach wave emission**
- **Time-resolved CFD/CAA for jet aeroacoustics**
 - **LES for non-compact sources, LEE for complex propagation in shocked flow**
- **Assessment of supersonic noise prediction tools**
 - **Empirical, statistical, and time-resolved codes**

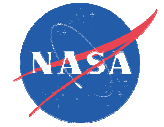

Prediction and Measurements of Broadband Shock-Associated Noise

PI: Philip J. Morris, Penn State U.

- No method exists to predict broadband shock-associated noise for general jet geometries and conditions
- Acoustics and flow-field measurements to be performed at small and moderate scale
- Steady RANS flow simulation coupled with source modeling based on measured unsteady flow properties will provide noise prediction
- Separation of shock-associated noise from other jet noise sources accomplished using new empirical method
- Close collaboration between Penn State, Boeing and NASA – good progress in all sub-tasks

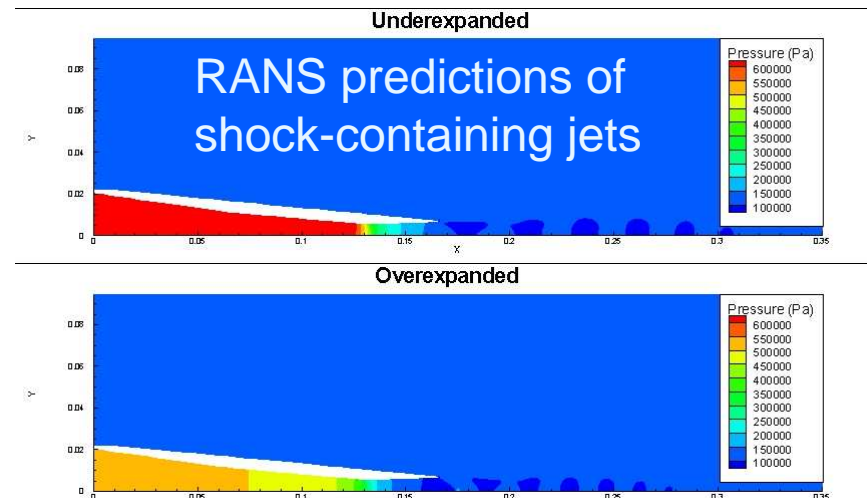
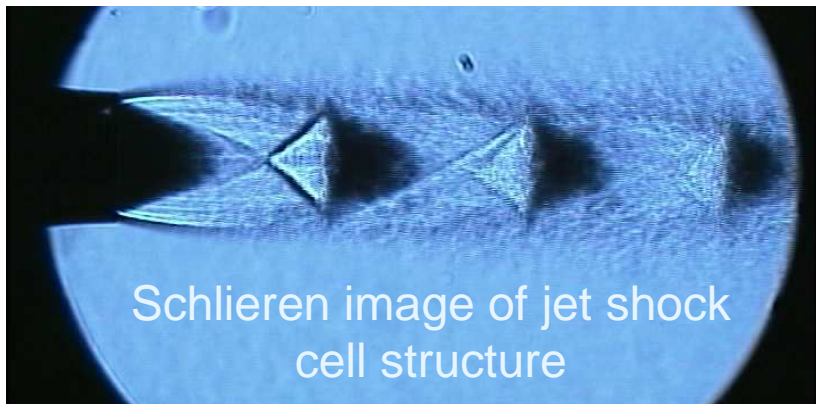
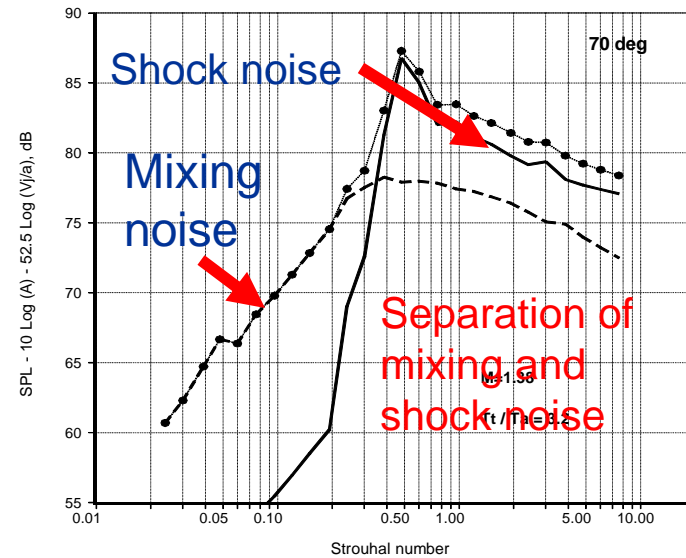

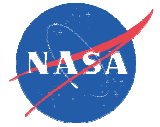

Diagnostics

- **Phased array diagnostics for source distribution**
 - Combine flow and acoustic array measurements
- **Turbulence statistics for noise prediction codes**
 - Mixing noise, shock noise, Mach wave emission
- **Supersonic aeroacoustic database**
 - Far-field noise and source distribution for range of geometries (dual stream, round, rectangular, twin)

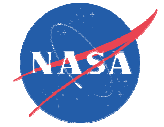

LSAWT Phased Array Experiment

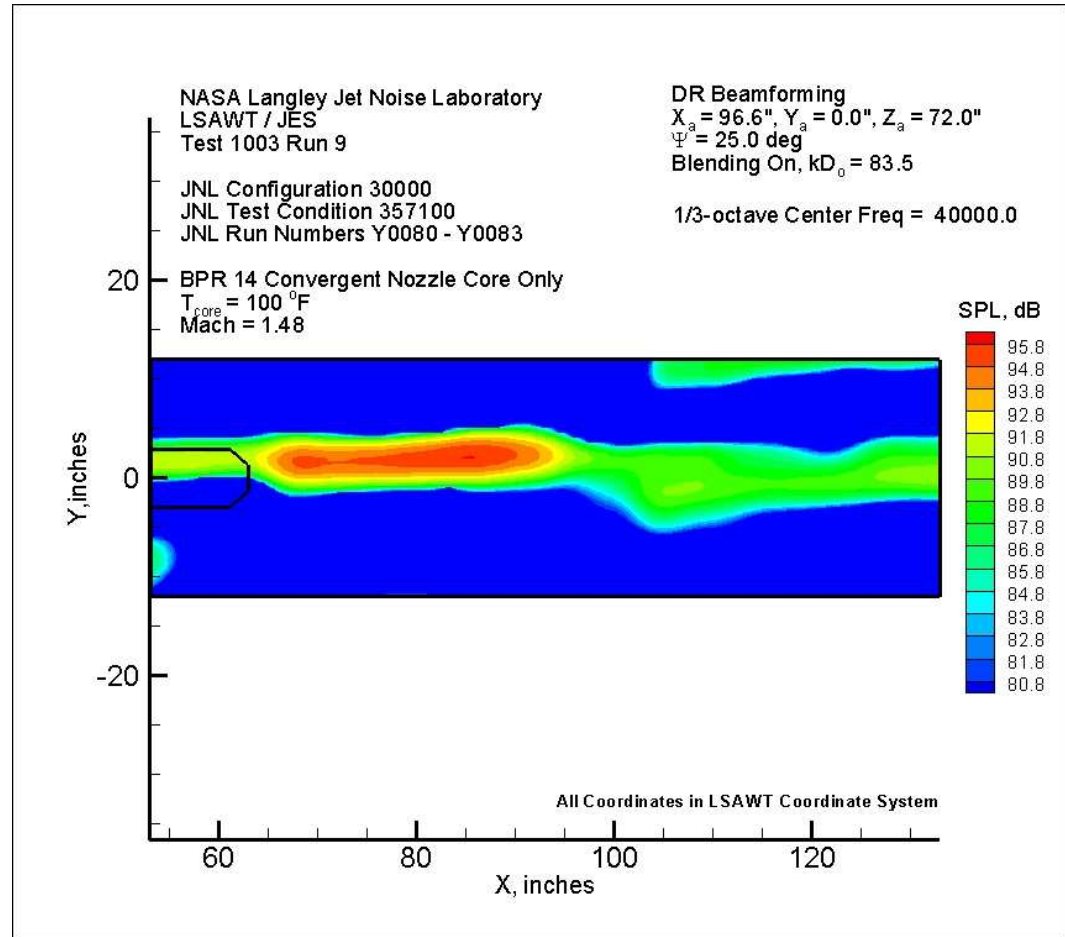
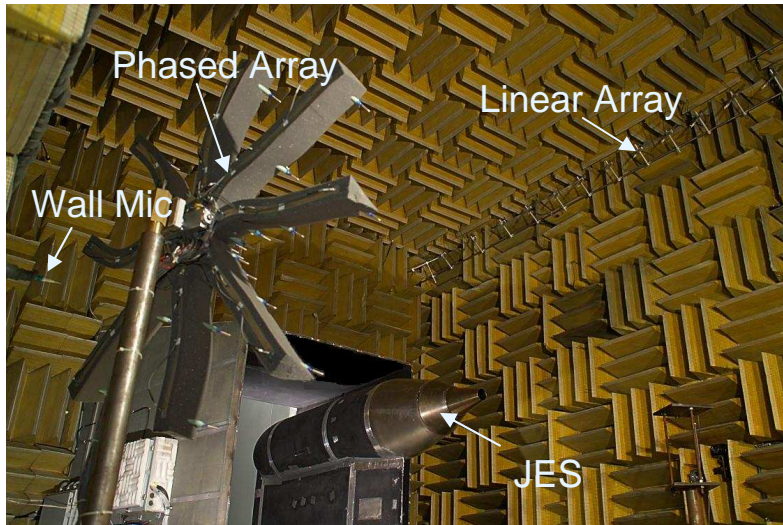

- Detailed source distribution maps obtained for subsonic and supersonic jets using conventional beamforming
- Next step - DAMAS deconvolution to resolve shock noise source distribution in plume

Application of Time-Resolved PIV to Supersonic Hot Jets

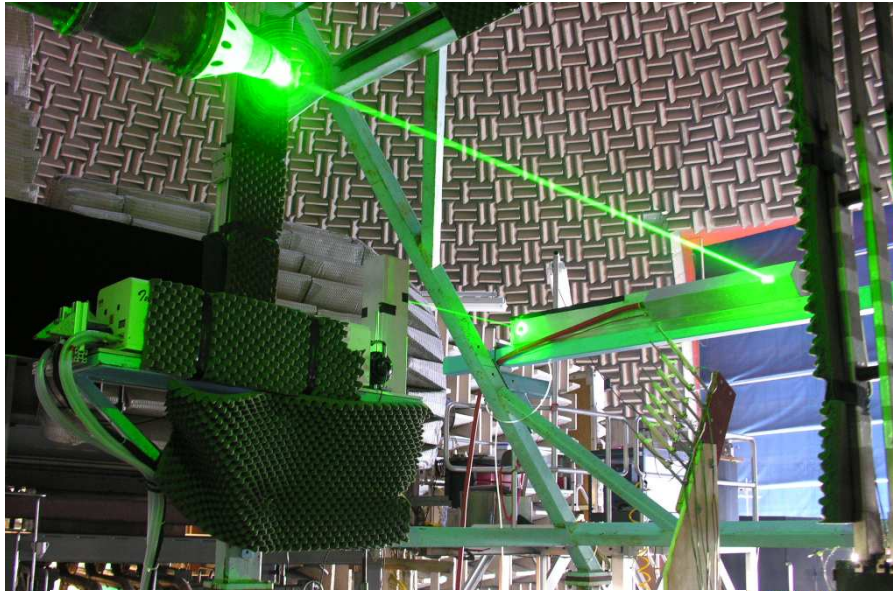
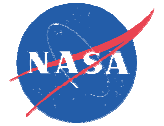

NASA Glenn AeroAcoustic Propulsion Lab

Advanced turbulent velocity measurements yield space-time statistics required to model jet noise sources and validate CFD-based prediction codes.

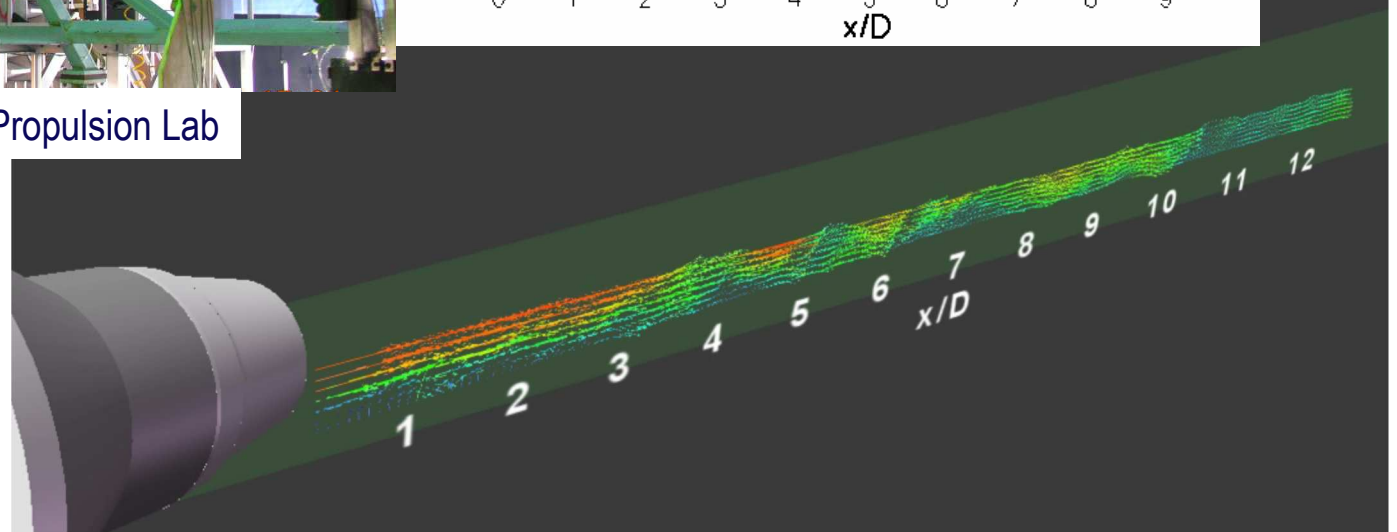
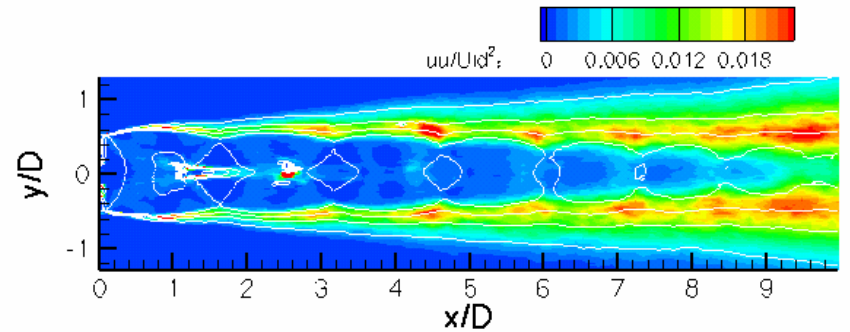

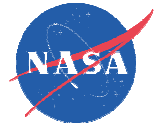

Twin Jet

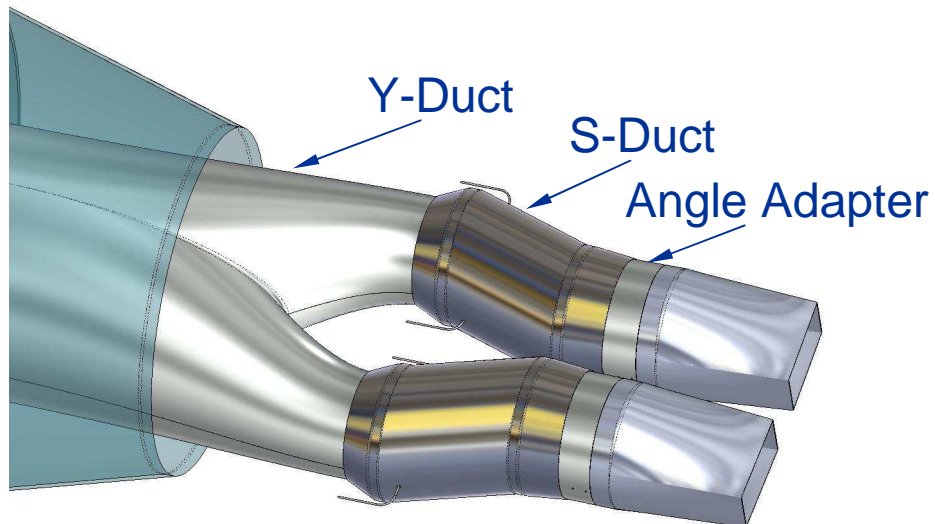

Investigate

- Jet plume interactions
- Noise characteristics of rectangular nozzles

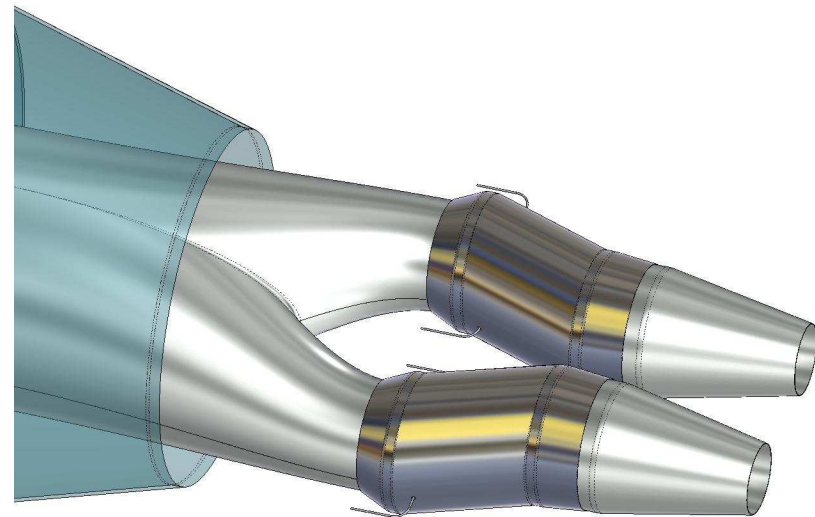

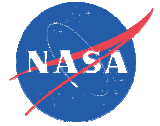

Engineering

- **Broadband shock noise reduction through shock modifications**
 - Air injection
- **Offset stream nozzles for noise reduction**
- **Unsteady actuator for time-dependent jet control**
 - LES-optimized temporal control of jet instabilities and medium-scale testing

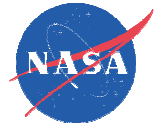

Strategic Environmental Research & Development Program

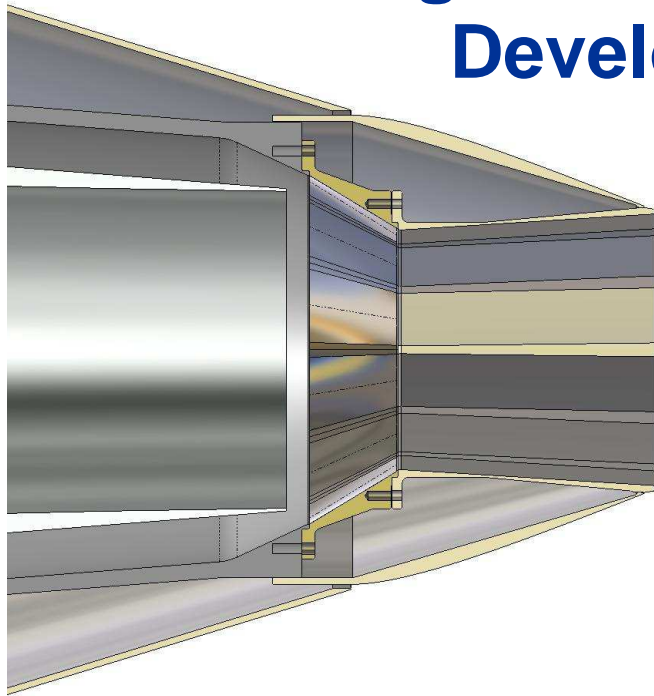

Investigate

- Noise characteristics of realistic nozzle geometries
- Impact of bypass flow on acoustic radiation and noise reduction devices

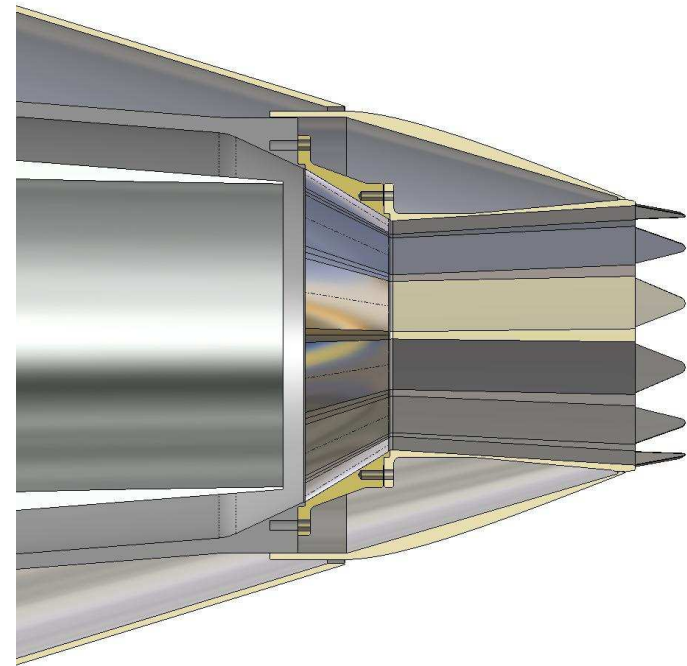

Air Injection

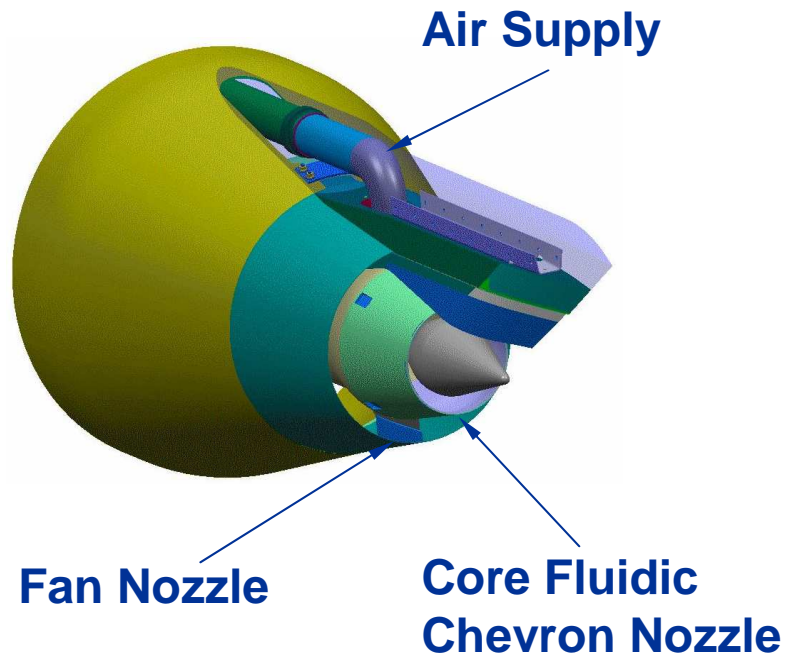
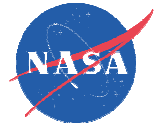

Noise reduction can be achieved in single and dual stream jets

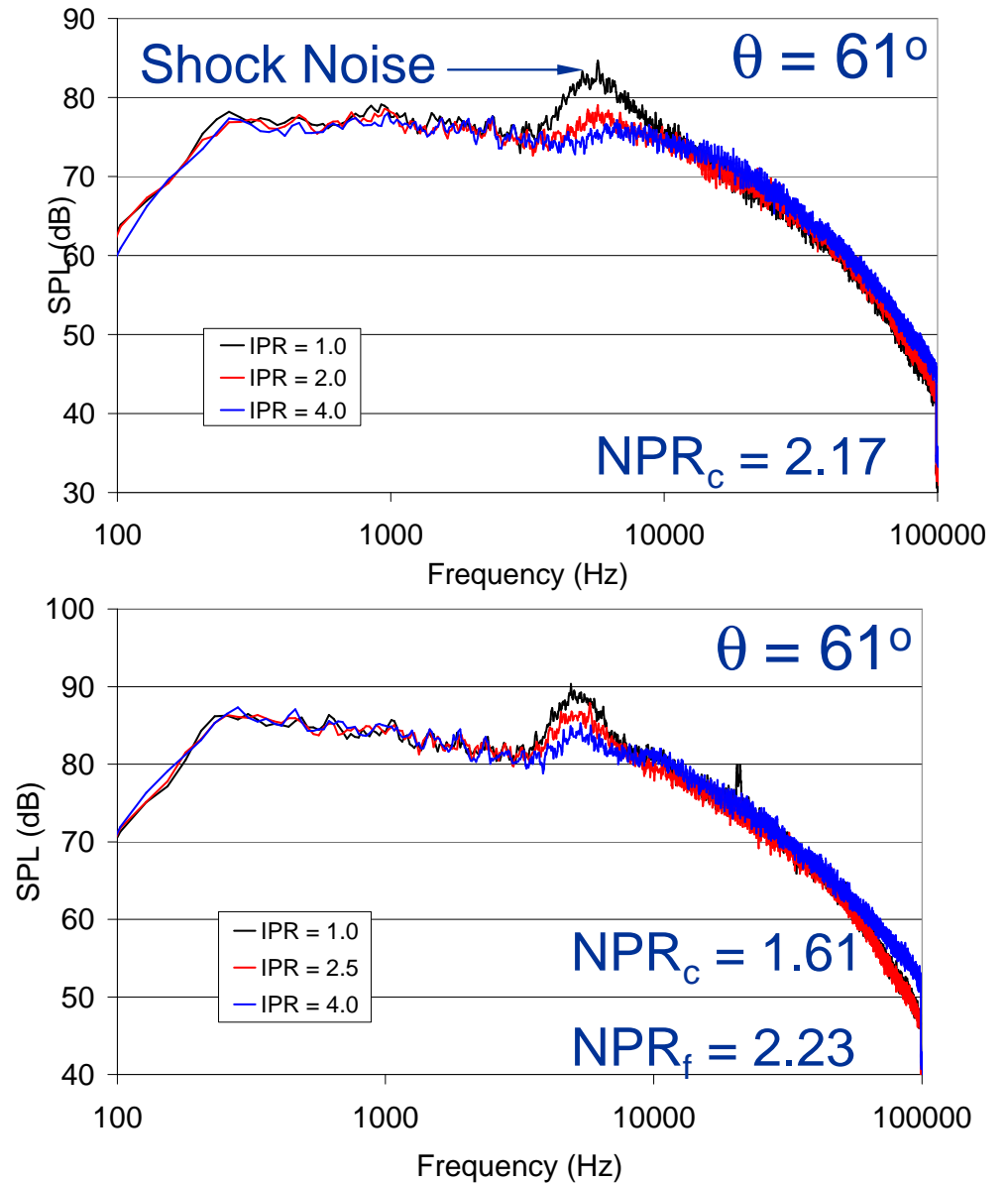

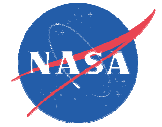

Realistic Expectations

- **With history as a guide, don't expect this problem to be solved soon.**
- **High performance aircraft cannot rely on engine cycle benefits the way commercial aircraft have met large noise reduction targets.**
- **Commercial aircraft have benefited from sustained noise reduction research. This has not been done for high performance aircraft engines, which means the foundation for this research is less mature.**
- **Small reductions in jet noise (a few EPNdB) are expected to be possible with small performance penalties (< 0.5%). Retrofitable solutions may be possible (i.e. Chevron Nozzles).**
- **Large reductions in noise will require a long-term research commitment and consideration for noise during initial design of engine. Variable cycle engines are needed to make significant progress.**
- **Modified aircraft operations for noise abatement is a good solution for community noise problems. Barriers, acoustic enclosures, and ear protection are the most practical solutions for near field noise problems.**

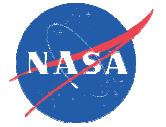

(Back-Up Slides)



Effective Perceived Noise Level, EPNdB - 1000 ft, Takeoff power

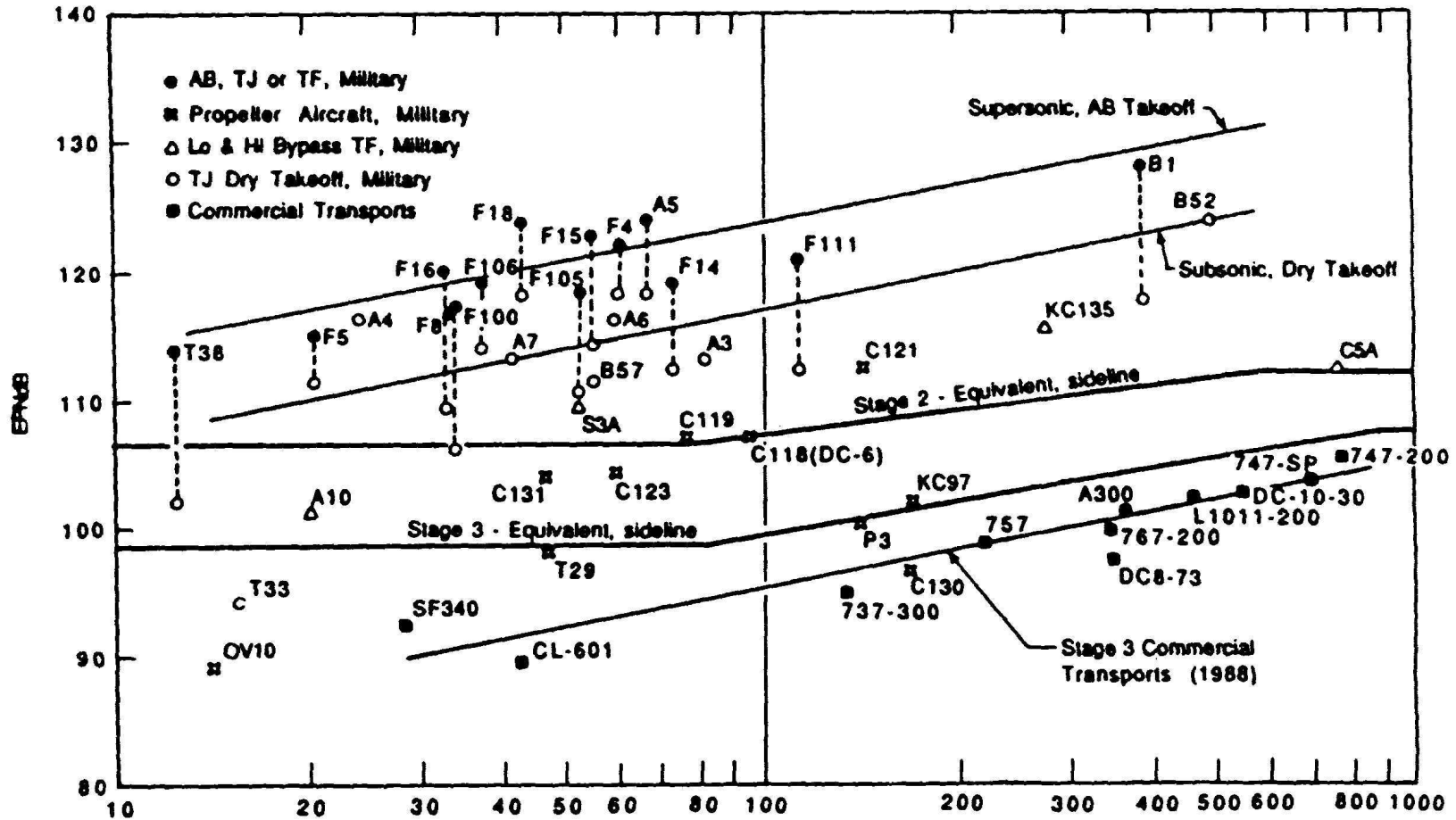

Pinker, R.A., "A Brief Review of the Source Noise Technology Applicable to Fixed-Wing Military Aircraft", AGARD-CP-512, Combat Aircraft Noise, 1991)

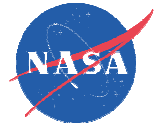

Highlights From NASA's HSR Program

Noise research focused on improving low bypass ratio turbofans with variable geometry mixer-ejector nozzles

- Mixer on primary flow reduces low frequency jet noise
- Acoustic liners absorb high frequency noise
- Fan inlet noise issue during approach, addressed through improved design

Major Technology Improvements

- Better mixer designs aided by 3-D CFD (reduced thrust loss)
- Improved acoustic liners (higher temperature, lower weight)
- Technology available to provide engine that can meet commercial certification requirements (Stage III with ~2-4 dB margin => Stage IV)
- Improved materials technology beat original engine weight goals

Jet noise reduction achieved, but required heavy mixer-ejector nozzle

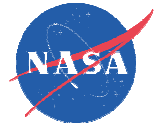

High-Speed Civil Transport Jet Noise

Model Test Data Projections

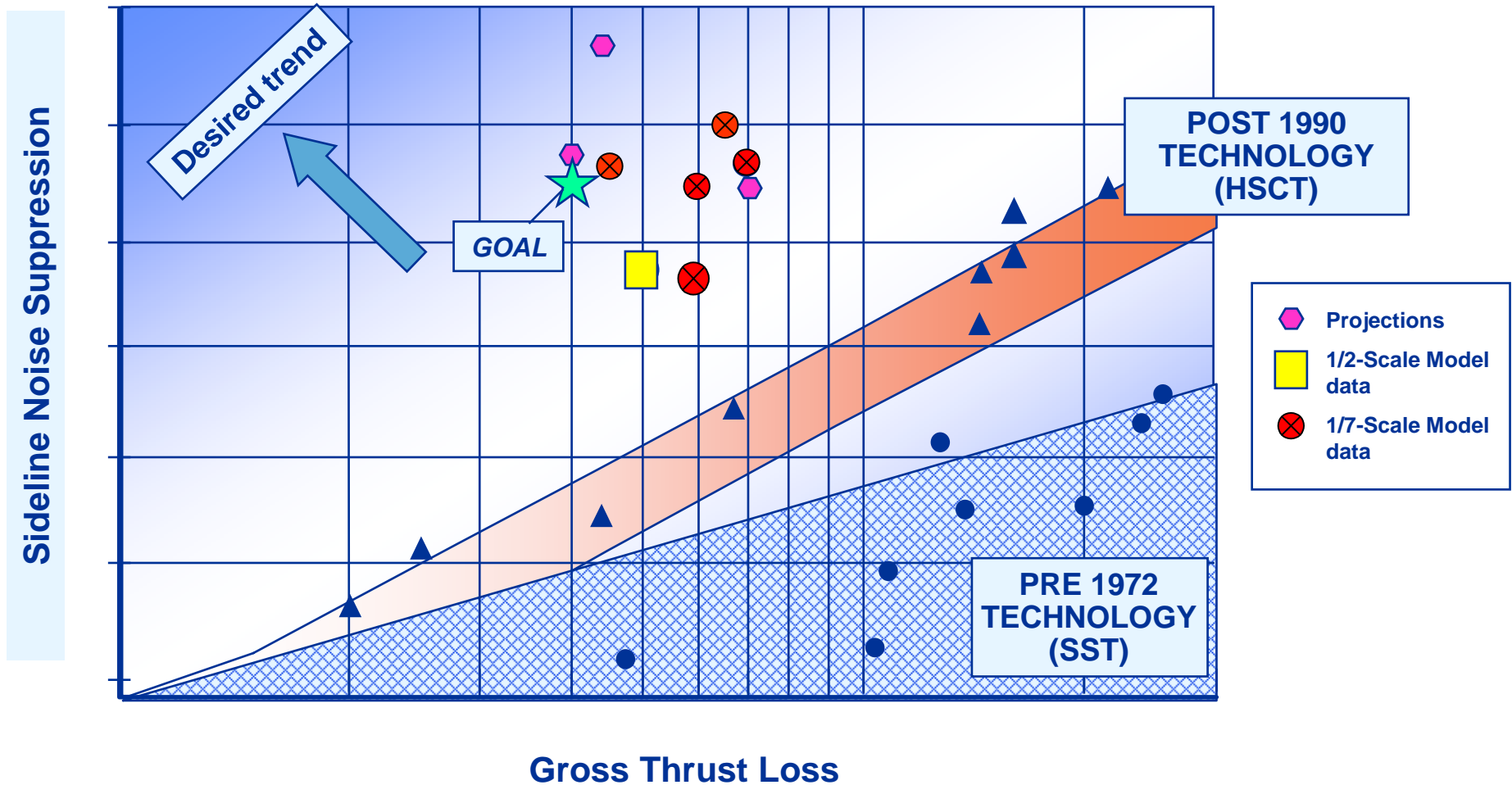

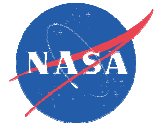

NASA Dryden Flight Research Center Photo Collection
<http://www.dfrc.nasa.gov/gallery/photo/index.html>
NASA Photo: EC98-44511-1 Date: 14 Apr 1998

F-15 ACTIVE in flight

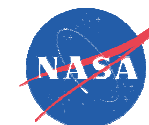

F-15 ACTIVE ACOUSTIC FLIGHT TEST EFFECTS OF FLIGHT SPEED ON JET NOISE

Fully expanded Mach number $M_j = 1.45$ Nozzle exit Mach number $M_e = 1.73$

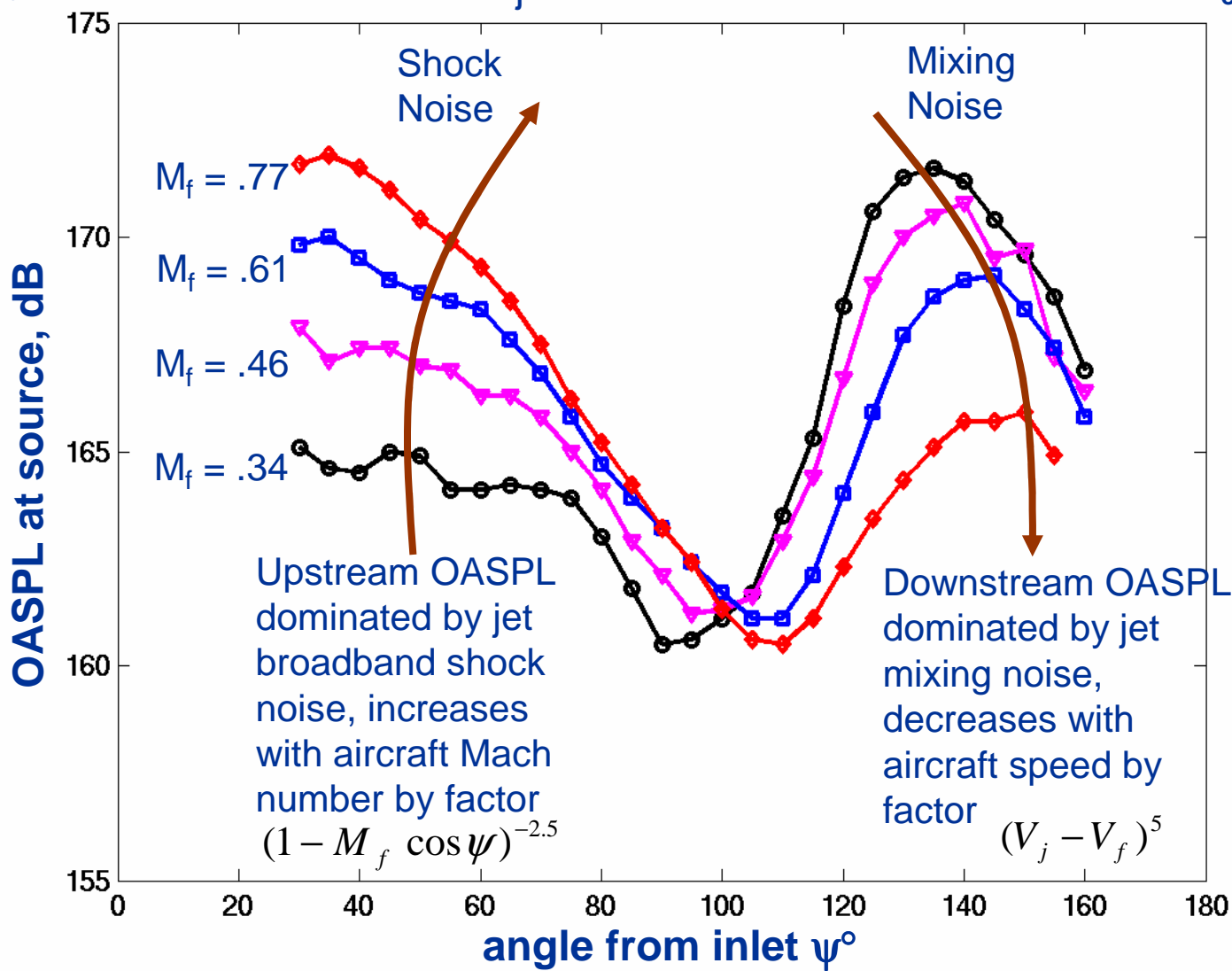

From T. Norum, NASA Langley Research Center



Highlights From NASA's Subsonic Research

Higher Bypass Ratio



Scarf Inlets



Forward-Swept Fans

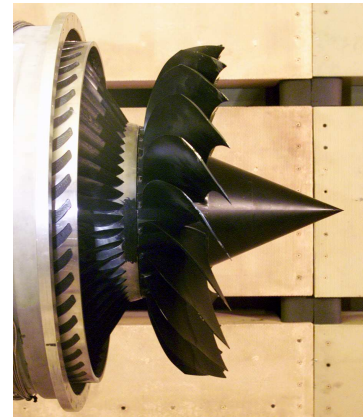

Swept/Leaned Stators

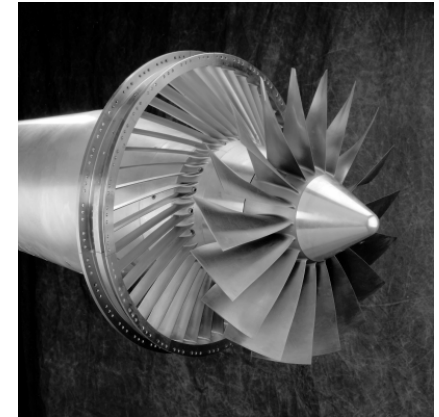

Chevron Nozzles



Noise Prediction

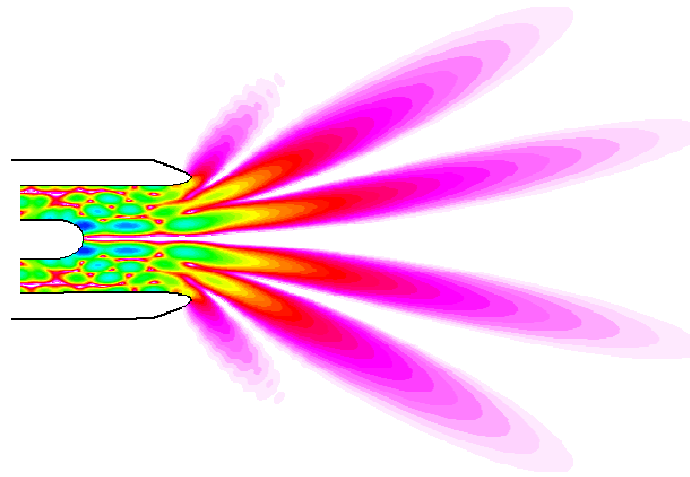

Active Noise Control

