



Battery Control Boards for Li-Ion Batteries on Mars Exploration Rovers

**R. Ewell, B. V. Ratnakumar, M. Smart, K. B Chin,
L. Whitcanack, S. R. Narayanan and S. Surampudi**

**Jet Propulsion Laboratory
California Institute of Technology**

**NASA Battery Workshop
Huntsville, AL, November 16-19, 2004**



MARS EXPLORATION ROVER



Mars Exploration Rover

To Date

- About 290 sols completed
- Evidence of past water

Payload

- Panoramic Camera
- Miniature Thermal Emission Spectrometer (Mini-TES)
- Mössbauer Spectrometer
- Alpha Particle X-Ray Spectrometer (APXS)
- Magnets
- Microscopic Imager (MI)
- Rock Abrasion Tool (RAT)

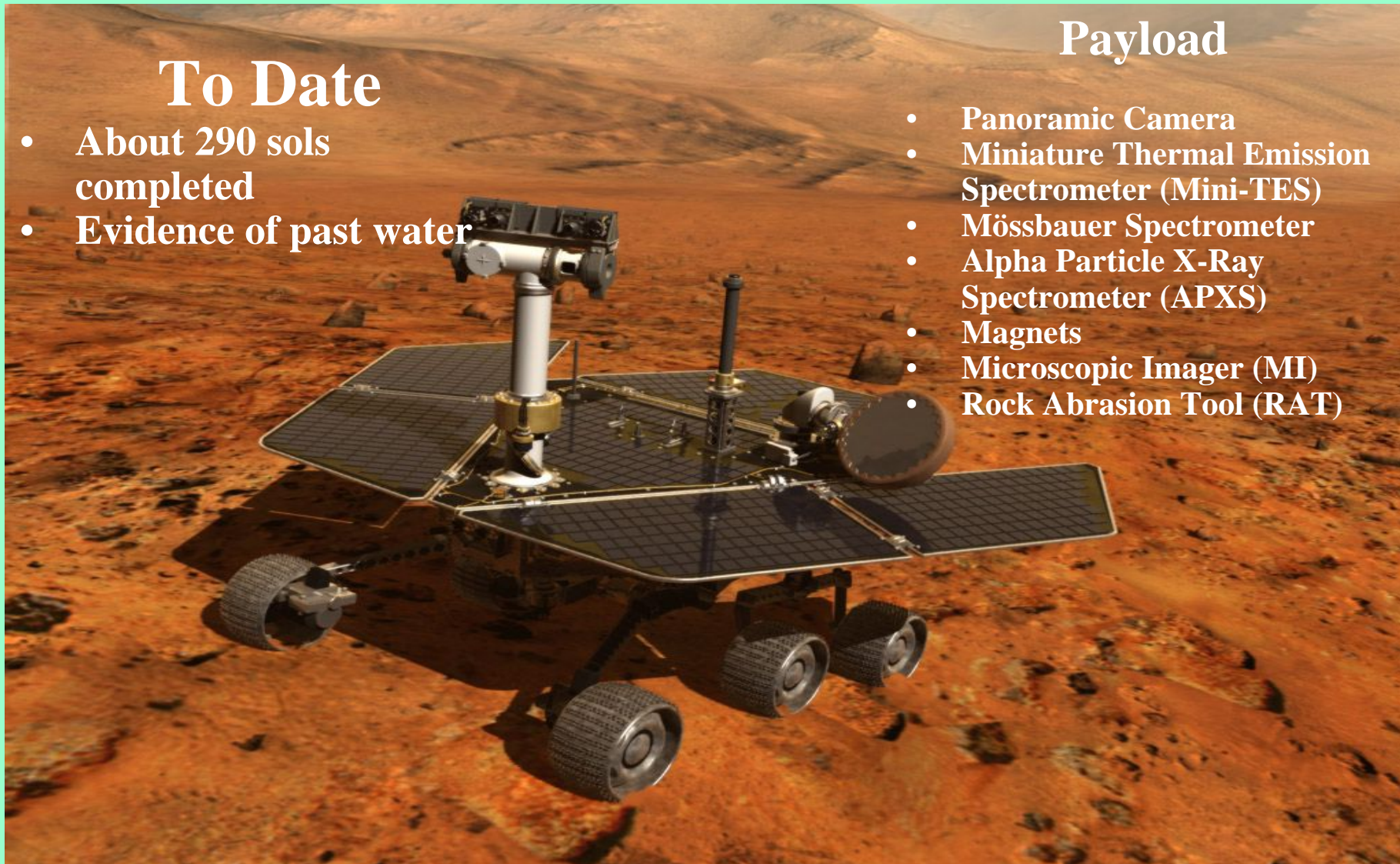



ROVER CAPABILITIES



Mars Exploration Rover

Avionics

- **Rad6000 Flight Computer (20Mhz, 128MB DRAM)**
- **256MB Non-volatile FLASH data storage**
- **Analog, digital, serial IO**
- **Motor control for 36 brushed motors, 4 stepper motors & 4 brushless motors**

Power

- **Triple-Junction GaInP/GaAs/Ge cell deployable solar arrays**
- **(2) 8A-hr Li-Ion rechargeable batteries**
- **Power conversion and distribution**

Navigation Sensors

- **Mast mounted stereo navigation cameras - NAVCAMs - Front & Rear stereo hazard cameras - HAZCAMs - with 120deg FOV) SUNCAM (mounted on HGA gimbal)**
- **6DOF IMU**

Telecom

- **Direct to Earth Communication (X-band) with fixed Low Gain and gimbaled High Gain Antennas**
- **Orbiter relay communication (UHF) with fixed monopole antenna**

Mobility System

- **6 wheel Rocker-Bogie mechanism with 25cm diameter wheels**
- **5cm/s top speed (~0.6m/minute under autonomous navigation)**

Thermal

- **Aerogel insulated Warm Electronics Box**
- **Resistive heaters on external motors/cameras and internal components**
- **Radioisotope heating units (RHUs)**
- **Battery thermal switch heat rejection system**
- **SSPA Loop Heat Pipe heat rejection system**



MER Rovers & Sojourner Spare Rovers



Mars Exploration Rover



- **First rover with a rechargeable battery, Lithium-ion.**
- **About ten times as big as the Sojourner Rover on Mars Pathfinder mission (1995 with a primary Li-SOCl₂ battery)**



Rover Battery Assembly Unit



Mars Exploration Rover

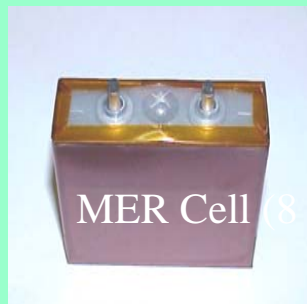

MER Cell (8 Ah)

MER Li Ion Cell(10 Ah).

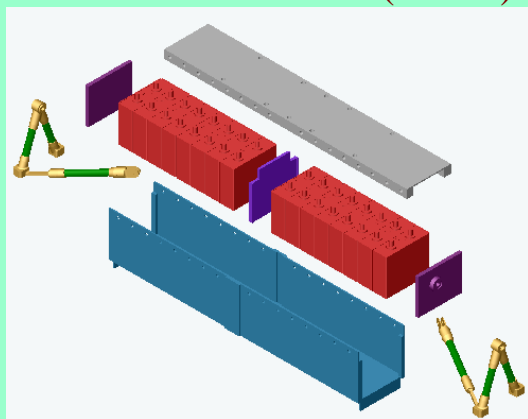

Advanced Li-ion battery for MER

- **Two parallel batteries each with eight (10 Ah) cells in series - 30 V, 16 Ah (480 Wh).**
- **Fabricated by Yardney Technical Products, CT (Lithion)**

- Low Temperature Electrolyte Development: At JPL under Mars Exploration Program (92-96)
- Cell Development: AFRL, NASA GRC, JPL, RDECOM, with Yardney Technical Products and SAFT: (97-01)
- Performance Database Dev. : JPL, NASA-GRC (97-03)
- Flight Hardware Design & Fabrication: JPL, Yardney (01-03)
- Battery Operational Strategies: JPL (02-04)



Need for Cell Balance on Charge



Mars Exploration Rover

- Li-ion cells diverge, both during cycling and storage even after a thorough matching initially.
 - Moderate cycle life requirement (500 cycles).
 - About three years of calendar life; Seven months of cruise.
 - Low temperature operation.
- Low energy margins and deep DODs (40-50%).
- Overcharge of Li-ion cell results in performance degradation and/or safety event
 - Oxidative (or even reductive degradation of electrolyte; Structural instability of cathode and lithium plating at anode.
- Over-discharge results in copper dissolution.
- Individual cell monitor and control essential



Cell Divergence on Cycling



Mars Exploration Rover

40 % DOD LEO Cycling of 30 V- 25 Ah Li-ion Battery at 23°C Cell End-of-Discharge (EOD) Voltages

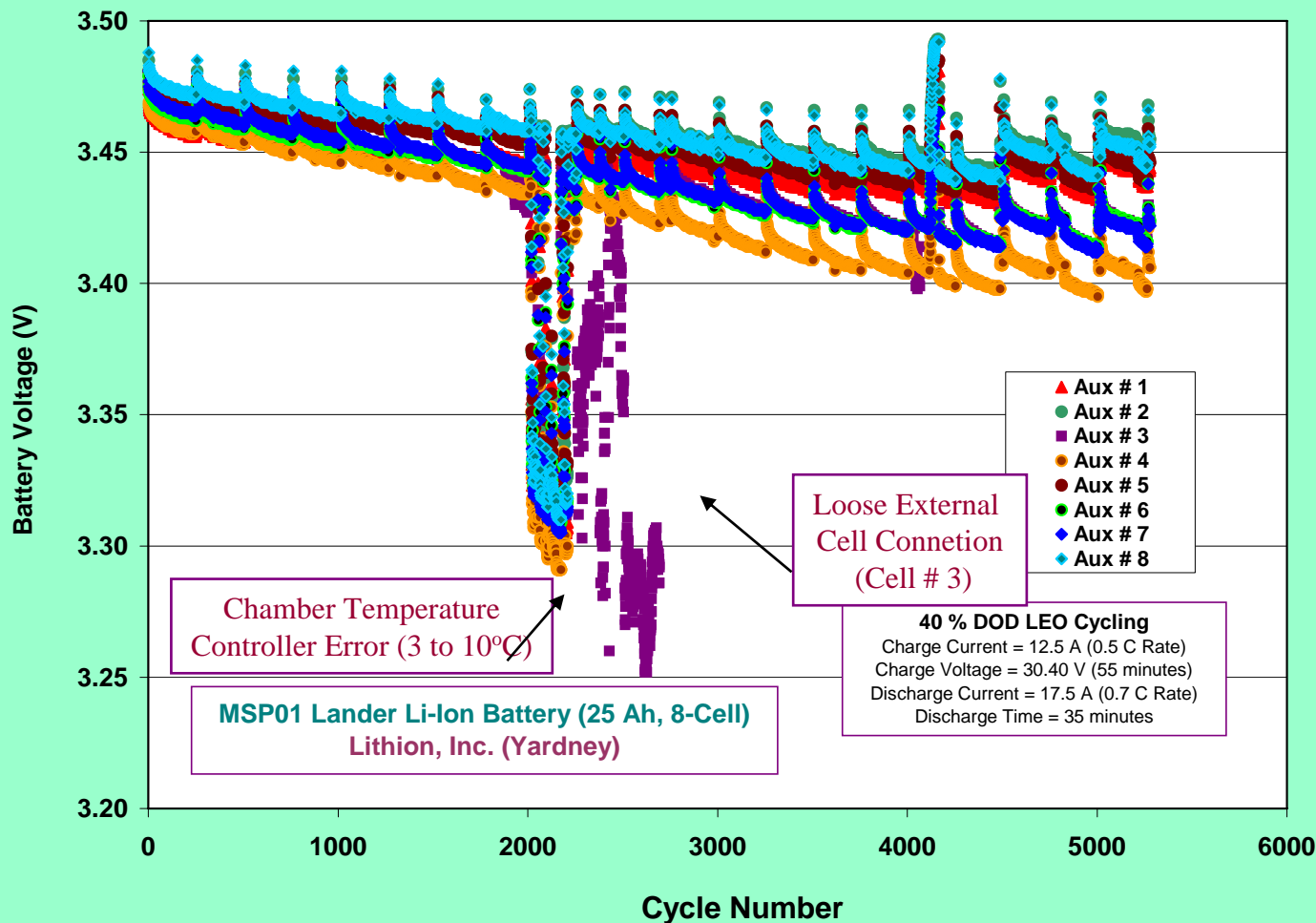



MER Power S/S Functional Block Diagram



Mars Exploration Rover

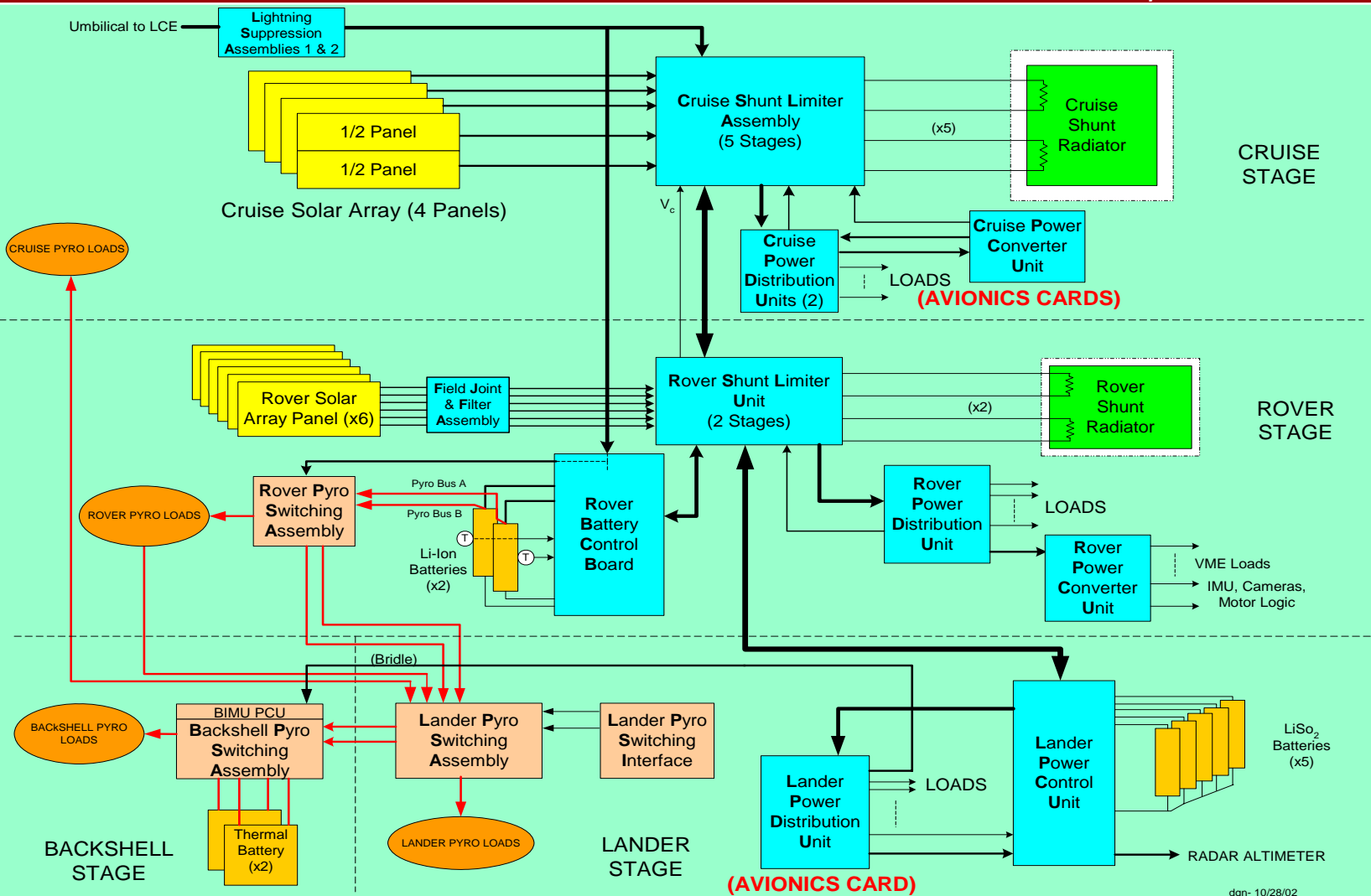



BCB Purpose relative to Li-ion Batteries



Mars Exploration Rover

- Autonomously control Li-ion Battery, continuously even when flight computer is not operating.
- Provides over-charge and over-discharge protection.
- Ensures all Li-ion cells are maintained with a maximum cell spread of 120 millivolts, assuming that the battery is fully charged periodically.
- Provides battery temperature control.
- Provides continuous battery telemetry and amp-hr integration.
- Fully functionally redundant



BCB: Description



Mars Exploration Rover

- Autonomously provides battery cell balancing to achieve maximum battery energy capacity.
- Switches on warm-up and survival heaters for the Rover batteries.
 - Heaters are thermostatically controlled.
- Isolates the Rover batteries from the power bus by use of relays.
 - For the main purpose of disconnecting the batteries from the bus during ATLO when the S/C is un-powered.
- Disconnects the Rover batteries from the power bus under cell over-voltage and cell under-voltage conditions by use of power FETS.
- Generates the wake-up signal to the RPDU to switch ON the VME.
 - Is based on either GSE wake-up, solar array current or wake-up timer.
 - Keeps the switch on for 240 seconds to allow the VME to boot up. The switch gets reasserted when the FSW is up and running properly.
- The BCB also has the capability of switching the VME OFF.
 - This is to ensure that if the VME does not properly boot up, the BCB can switch the VME off for 30 seconds and switch the VME back on again.



BCB: Block Diagram



Mars Exploration Rover

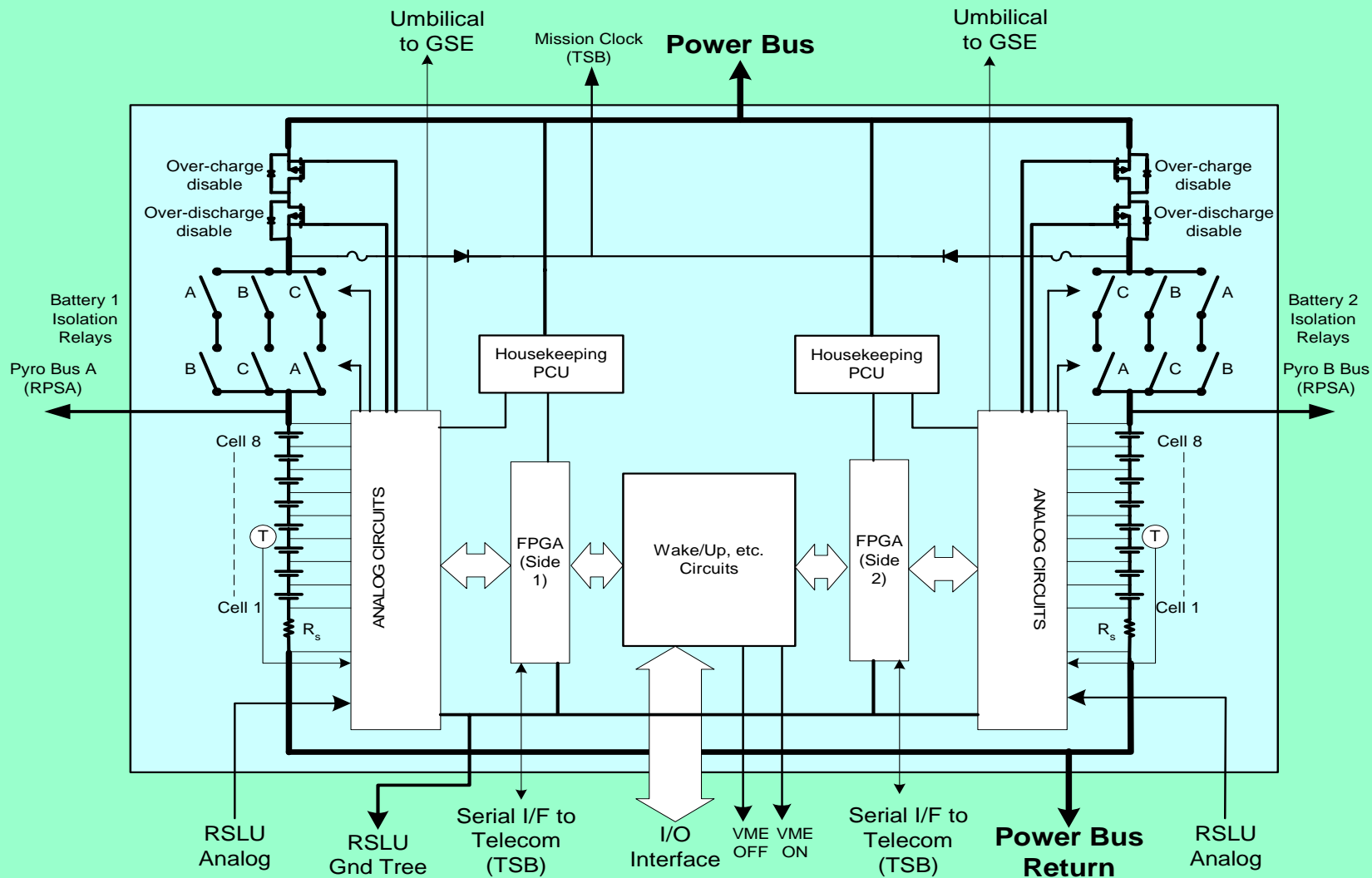



- Monitors all of the critical power analog telemetry signals in the Rover.
 - Rover solar array Voc and solar array Isc
 - Bus voltage
 - Rover solar array current
 - Rover shunt current
 - Lander bus current (bi-directional)
 - Cruise bus current (bi-directional)
 - RPDU current
 - Rover battery voltages
 - Rover battery cell voltages (8 per battery)
 - Rover battery currents (1 per battery)
 - Rover battery temperatures (5)
 - 3 internal, 1 battery case temperature, and routes 1 through umbilical.
 - Measures & stores critical night time measurements for thermal



BCB: Battery Control



Mars Exploration Rover

- We have 1 BCB for each battery. Each operates independently.
- Over-discharge protection: Opens the discharge FET if any cell voltage < 2.9 V for 3 samples of 1 second
- Overcharge protection: Opens the charge FET if any cell > 4.15 V, or if all cells above 4.12 V, or if any cell is below 1V while any other cell is > 2.9 V. (Cell short protection)
- Cell Balancing: Puts a resistor in parallel with cells that go above 4.12 V.
- BCB History: Each BCB stores all the analog measurements in a buffer every 10 minutes, whether the VME is on or not, up to 31 ²/₃ hours. We have reset the BCBs 5 minutes apart, so that most channels are sampled at 5 minute increments. By command, FSW can generate a data product that has user-selectable channels over a user-selectable duration.
- Battery Isolation Relays: Used only in the case of a battery failure.



BCB: Cell Balancing



Mars Exploration Rover

- Spacecraft has 8 hardware selectable levels of bus voltage control
 - Maximum bus voltage maintained by active shunt
 - Minimum bus voltage maintained by having Li-Ion batteries on bus
- Each side of BCB has 4 firmware selectable levels of cell charge control:
 - V_{cmd} : command value, if any cell voltage exceeds this value, battery is taken off of bus relative to charge by a FET
 - V_{bp} : bypass value, if any cell voltage exceeds this value, a shunt resistor is put in parallel with the cell as a partial shunt
 - V_{ebp} : end bypass value, if the voltage of any cell that was in bypass falls below this value it will be taken out of bypass
 - V_{ch} : charge value, when every cell voltage drops below this value, battery will be put back on bus relative to charge
- In addition each BCB has two firmware set values relative to discharge:
 - V_d : discharge value, ensure battery is on bus relative to discharge when every cell voltage is above this value
 - V_{sd} : stop discharge value, take battery off bus relative to discharge when any cell falls below this value



BCB: Cell Balancing Parameters



Mars Exploration Rover

Voltage Vcmd (FSW)	Actual Vcmd Voltage	V(bypass) Vbp = Vcmd - 30mv	V(end bypass) Vebp = Vcmd - 70mv	V(charge) Vch = Vcmd - 150mv	V(discharge) Vd = 3.4	V(stop) discharge Vsd = 2.9v
4.2	4.199	4.169	4.128	4.049	3.4	2.9
4.1	4.149	4.119	4.080	3.999	3.4	2.9
4.0	3.949	3.919	3.878	3.799	3.4	2.9
3.9	3.849	3.820	3.779	3.699	3.4	2.9



BCB: Typical Cell Balancing Parameters



Mars Exploration Rover

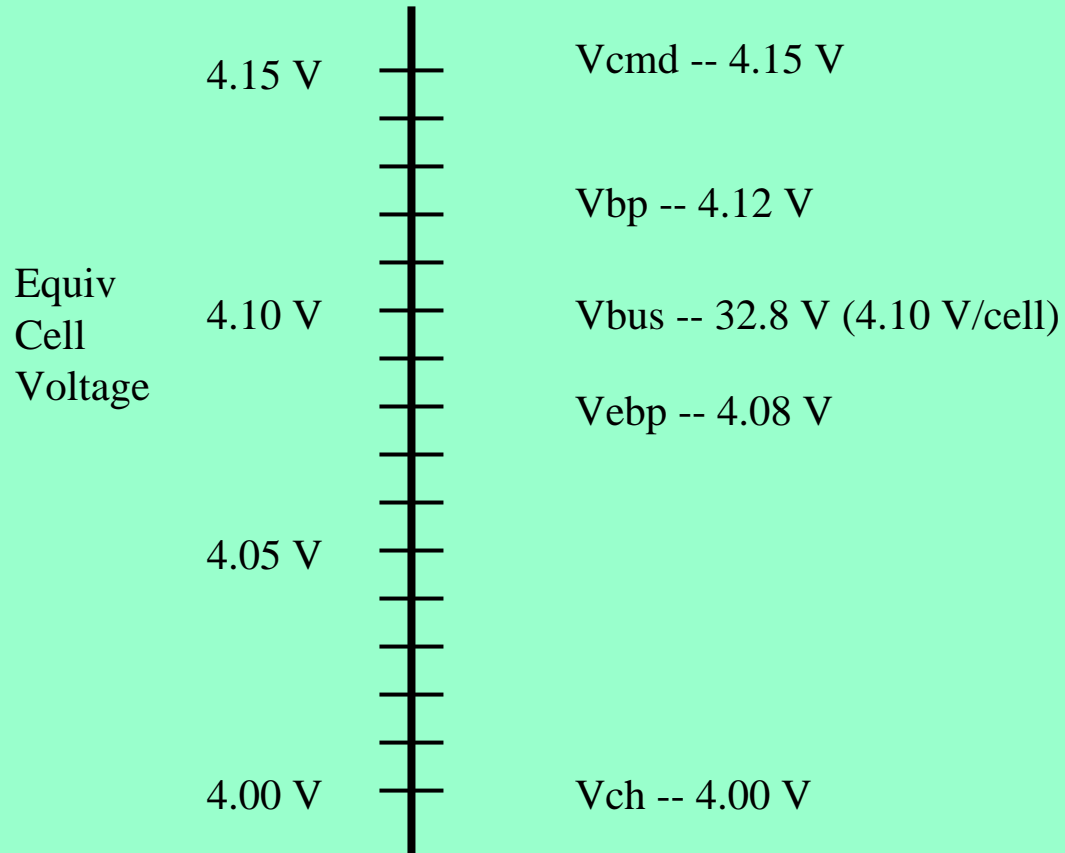



Battery Management Protocol



Mars Exploration Rover

- Charge control
 - Stop Charge (open charge FET) if:
 - Any cell is greater than or equal to V_{cmd}
 - All cells are above V_{bp}
 - Any cell is $<1V$ and the battery is $>20V$.
 - Start Charge (close charge FET) if:
 - All cells are below V_{ch}
 - After POR
 - Stop Discharge (open discharge FET) if:
 - Any cell is less than or equal to V_{sd}
 - Start Discharge (close discharge FET) if:
 - All cells are above V_d .
- Charge Balancing
 - Start cell bypassing at or above V_{bp}
 - Stop cell bypassing at or below V_{ebp}
- Terminology Definitions
 - $V_{cmd} = (V_{command}) = V_{sc} (V_{stop\ charge}) =$ one of four prog levels (3.85, 3.95, 4.15, 4.20V)
 - $V_{bp} (V_{bypass}) = V_{cmd} - 30mV$
 - $V_{ebp} (V_{end\ bypass}) = V_{cmd} - 70mV$
 - $V_{ch} (V_{charge}) = V_{cmd} - 150mV$
 - $V_d (V_{discharge}) = 3.4V$
 - $V_{sd} (V_{stop\ discharge}) = 2.9V$



BCB Flight Board (Front)



Mars Exploration Rover

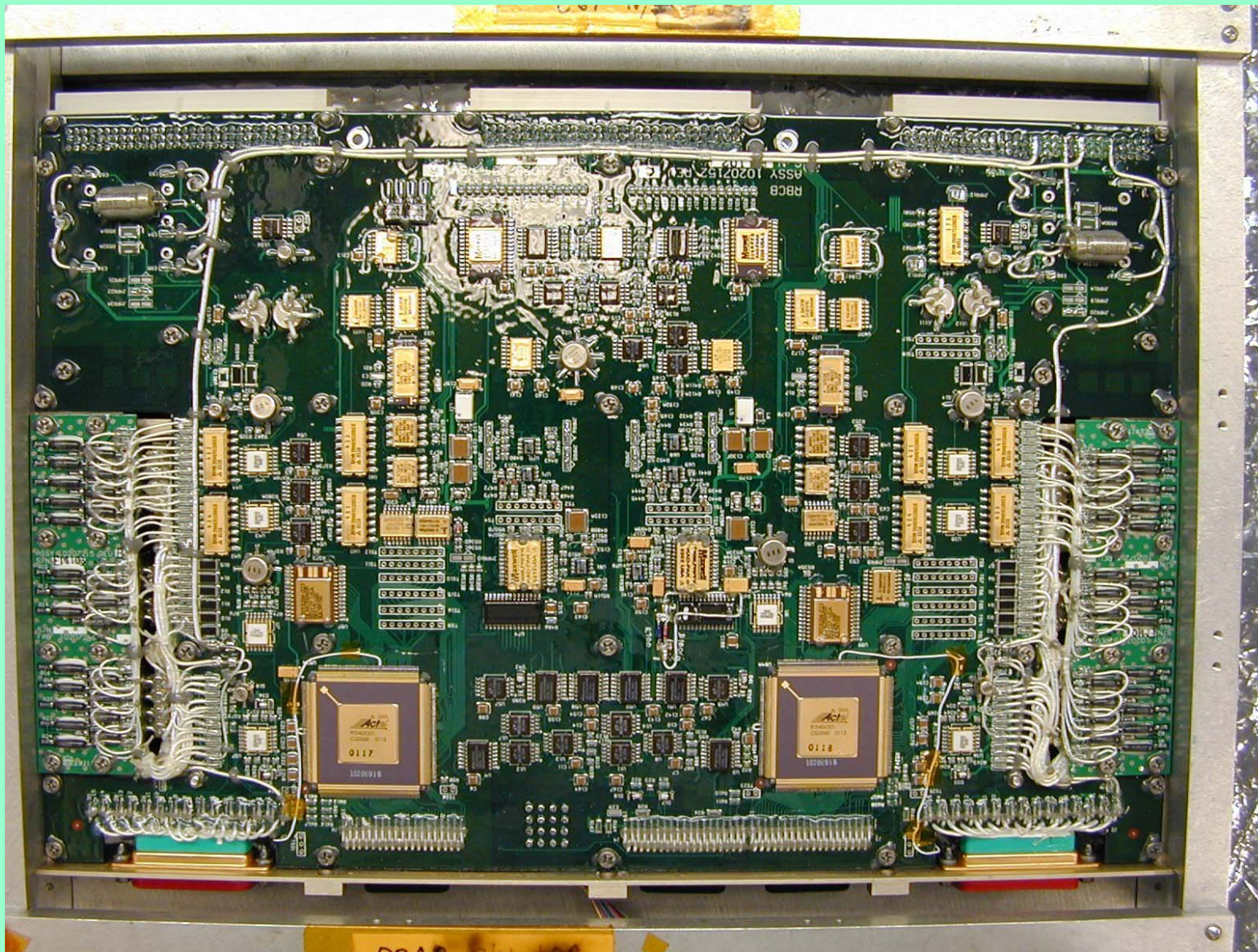



BCB Flight Board (Back)



Mars Exploration Rover

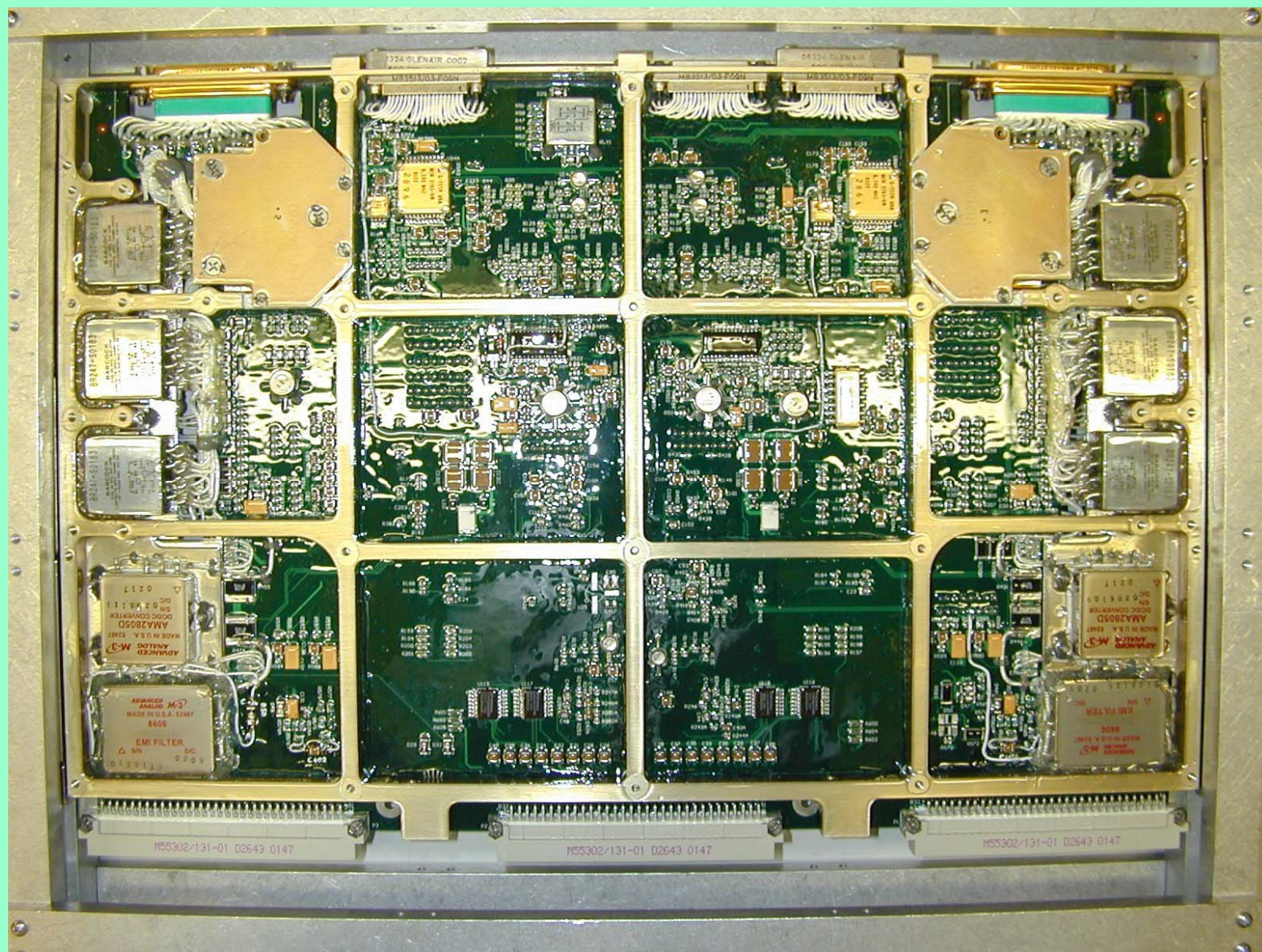



MER In-Flight Cell Balancing



Mars Exploration Rover

SPiRIT Cruise Battery 2 Cell Voltages

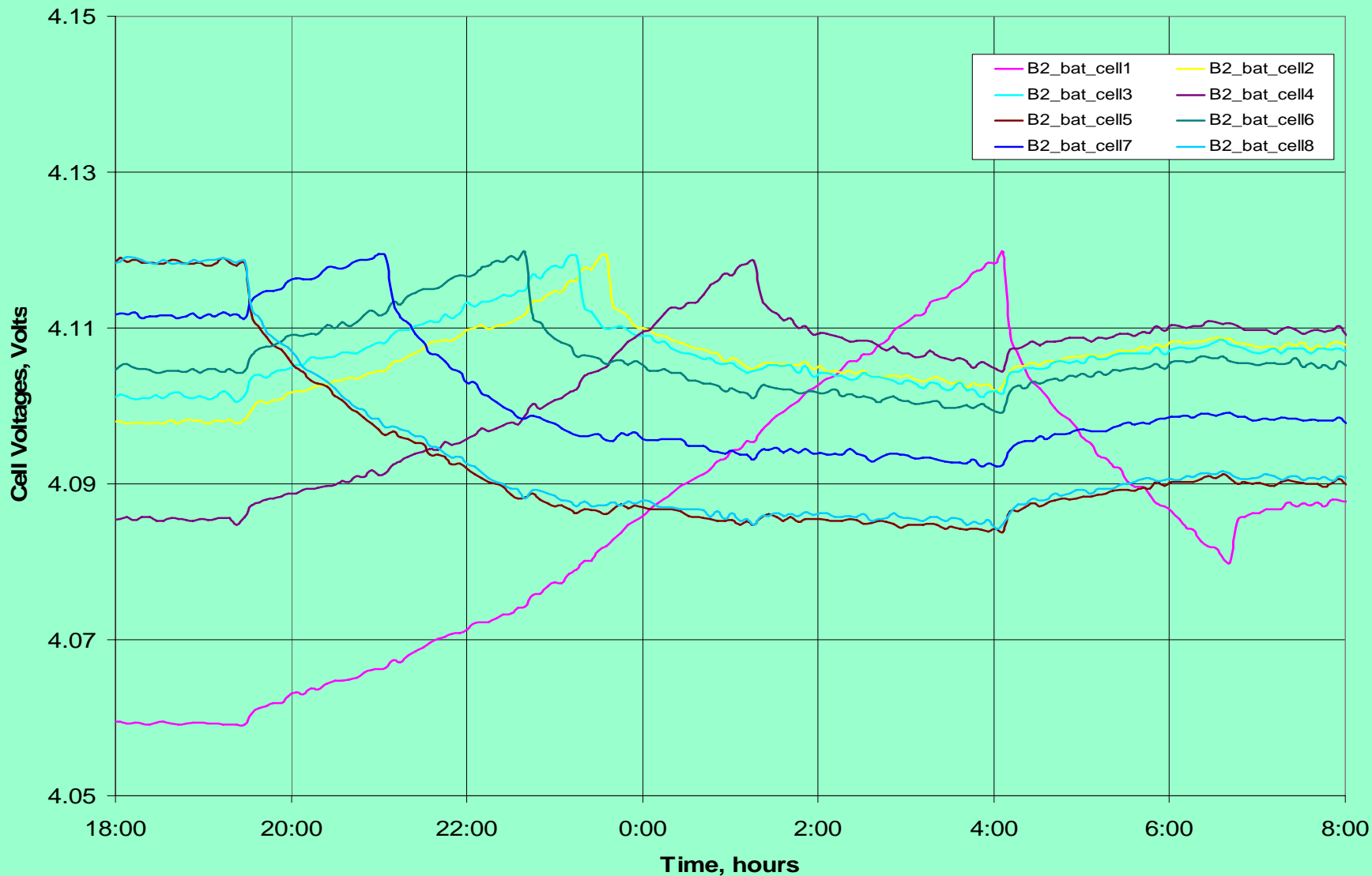



Spirit Li Ion Batteries on Cruise



Mars Exploration Rover

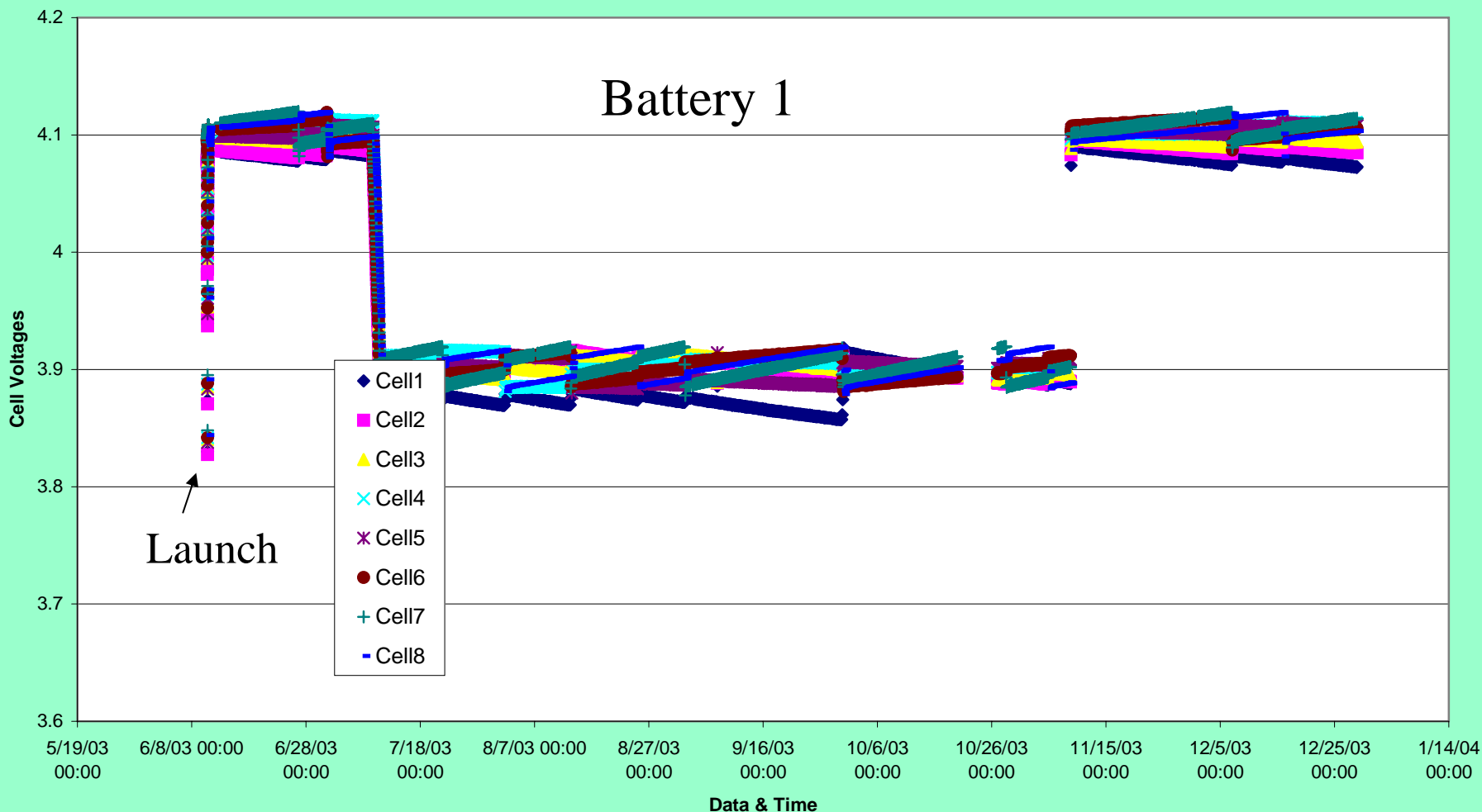

- ~ 25% discharge during launch. 80% SOC during cruise and fully charged before landing.
- Cells periodically balanced via bypass, if the cell divergence is sufficiently large.



Spirit Li Ion Batteries on Cruise



Mars Exploration Rover

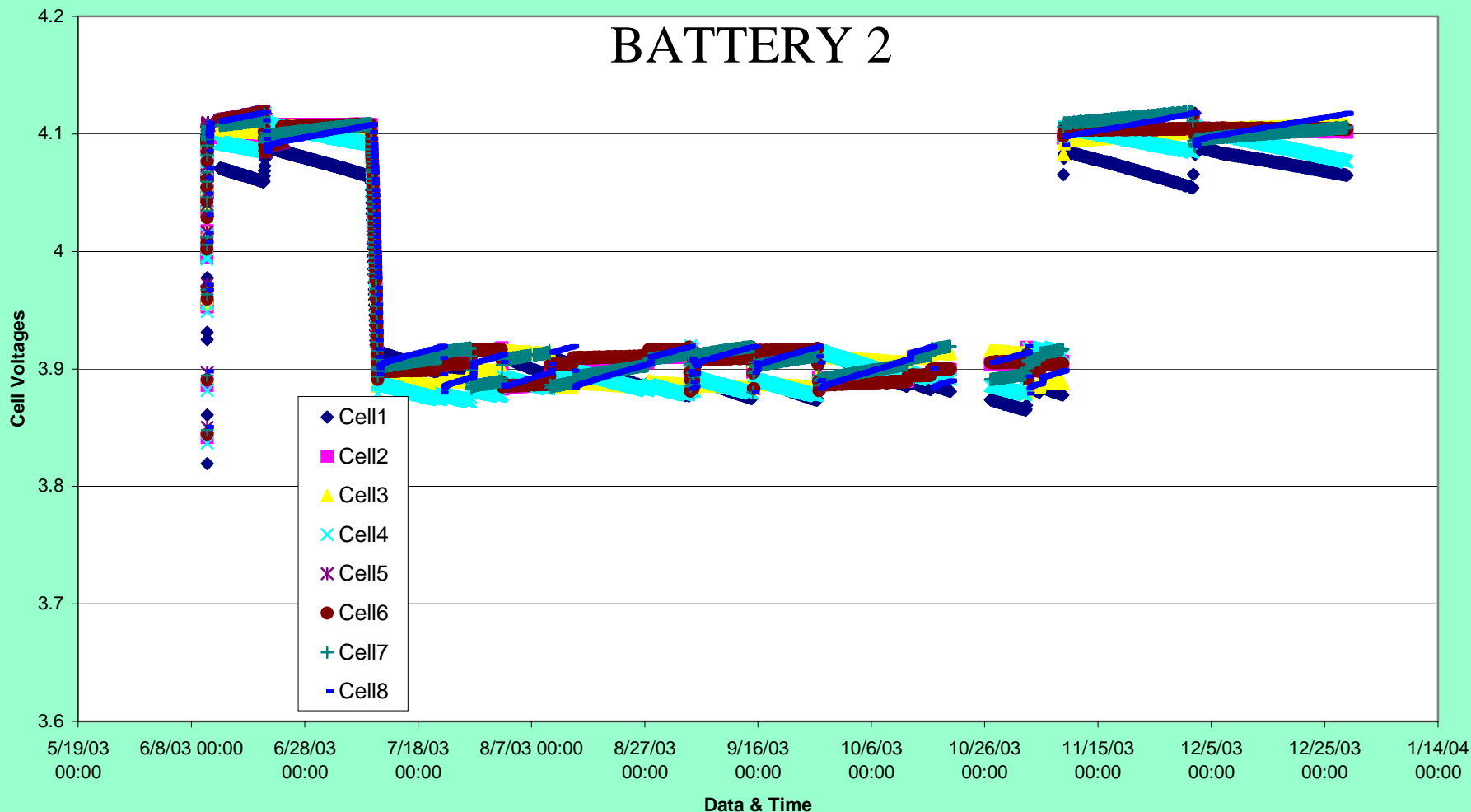

- Behavior of battery 2 is similar to battery 1
- Similar behavior on Opportunity as well.



Spirit Li Ion Batteries Thro' Sol 74



Mars Exploration Rover

Battery Voltages on Spirit

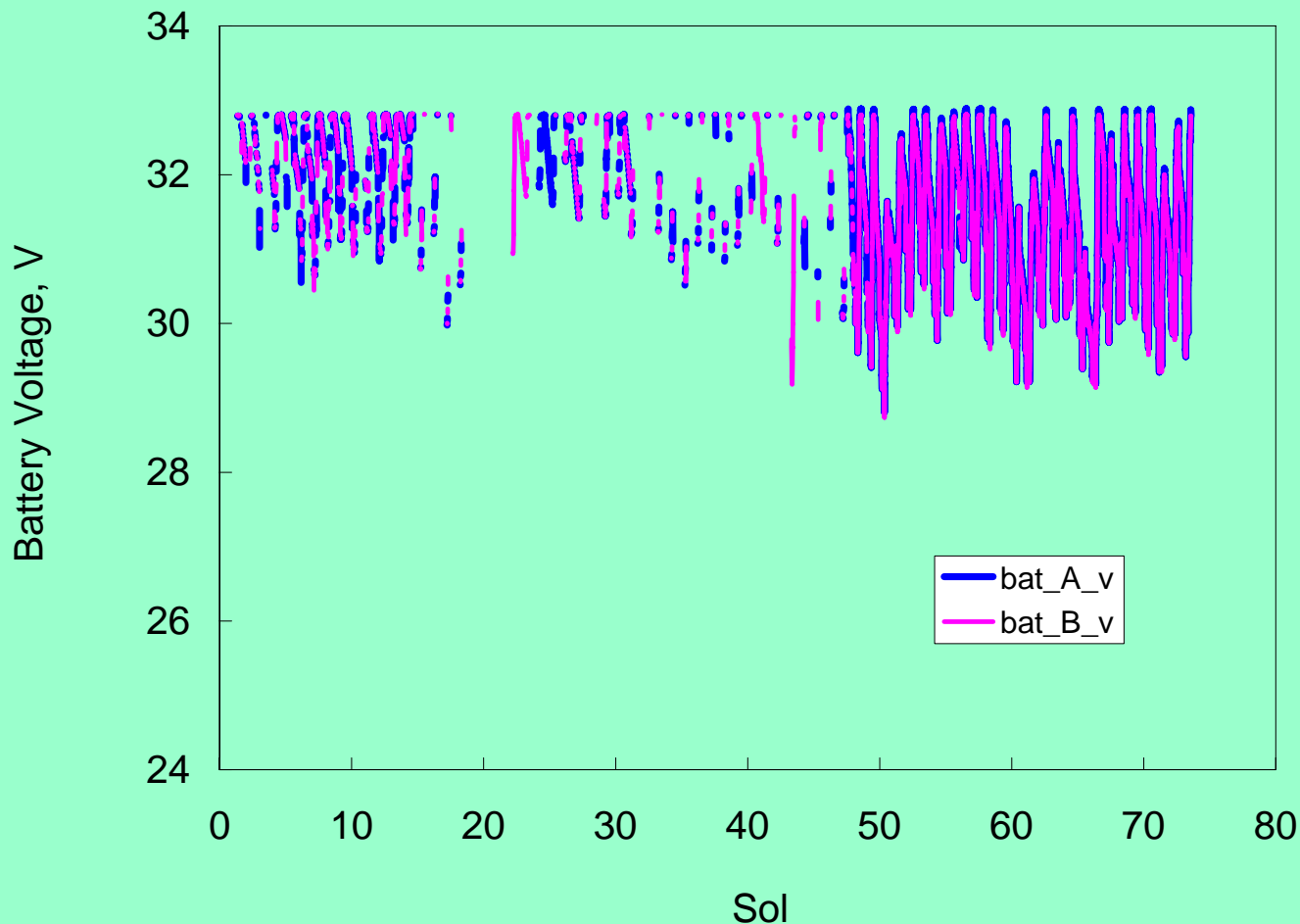

- End of discharge voltages are 29-30 V.
- Both batteries have nearly identical voltages



Spirit Li Ion Batteries Thro' Sol 74



Mars Exploration Rover

Cell Voltages on Spirit- Bat A

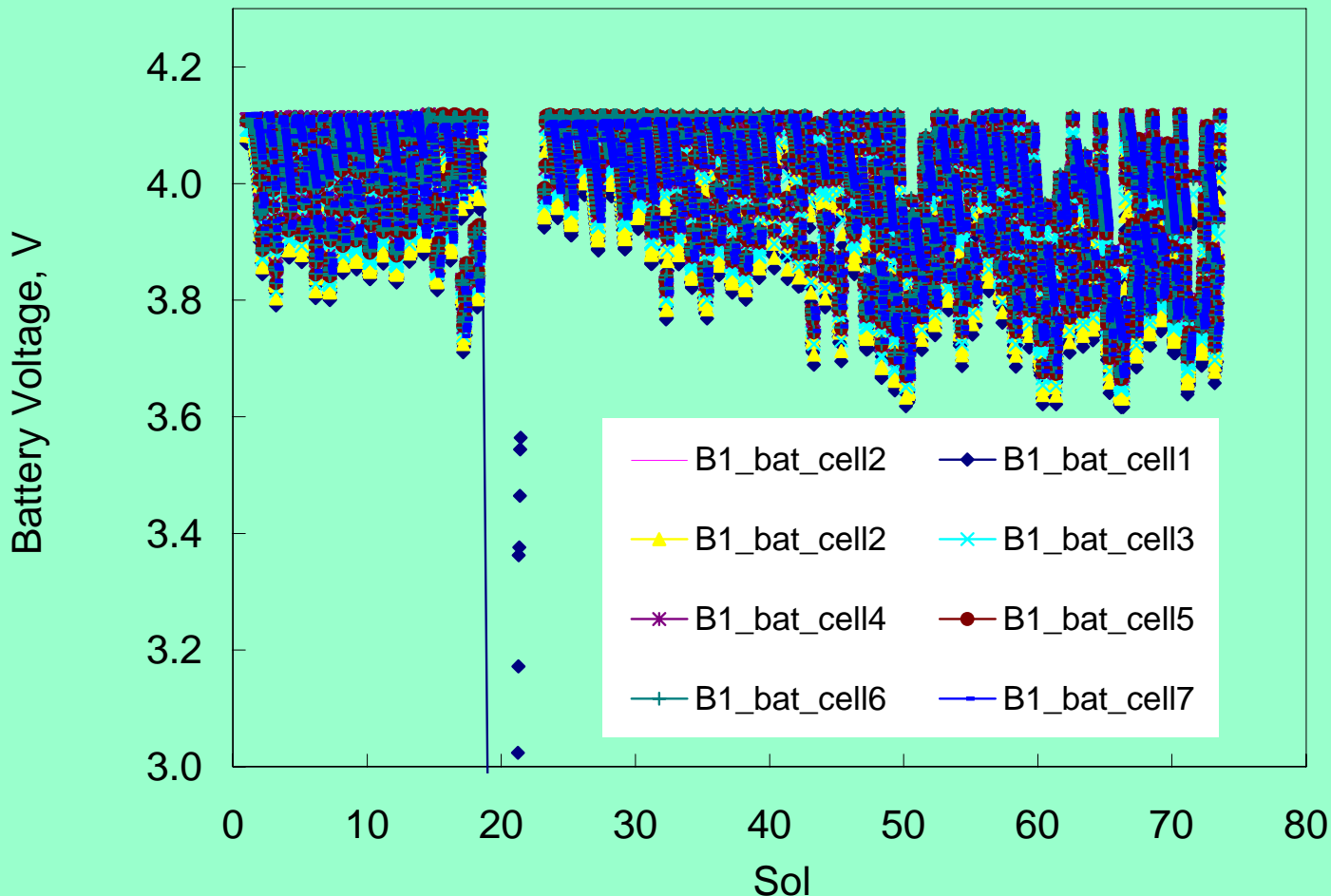

- **Typical minimum cell voltage : 3.6 V (~ 50%DOD)**
- **Spirit anomaly attributed to flash memory, which was later erased.**
- **Batteries experienced a fairly deep discharge and yet recovered well.**



Opportunity Li Ion Batteries Thro' Sol 54



Battery Voltages on Opportunity

Mars Exploration Rover

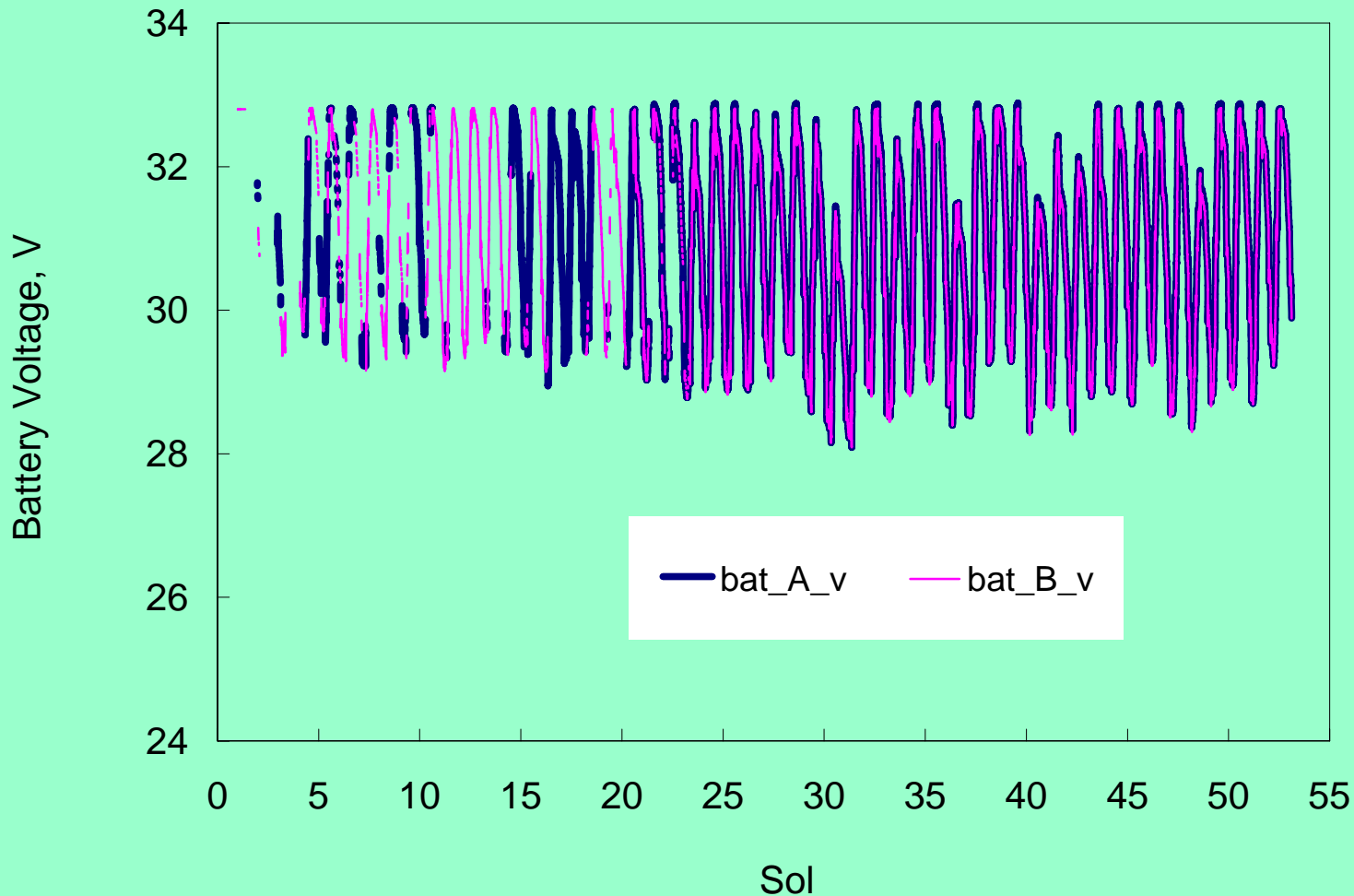

- Battery End of discharge voltage: 28 V; A little bit lower than in the case of Spirit.
- Both batteries have nearly identical voltages.



Opportunity Li Ion Batteries Thro' Sol 54



Mars Exploration Rover

Cell Voltages in Battery 1 on Opportunity

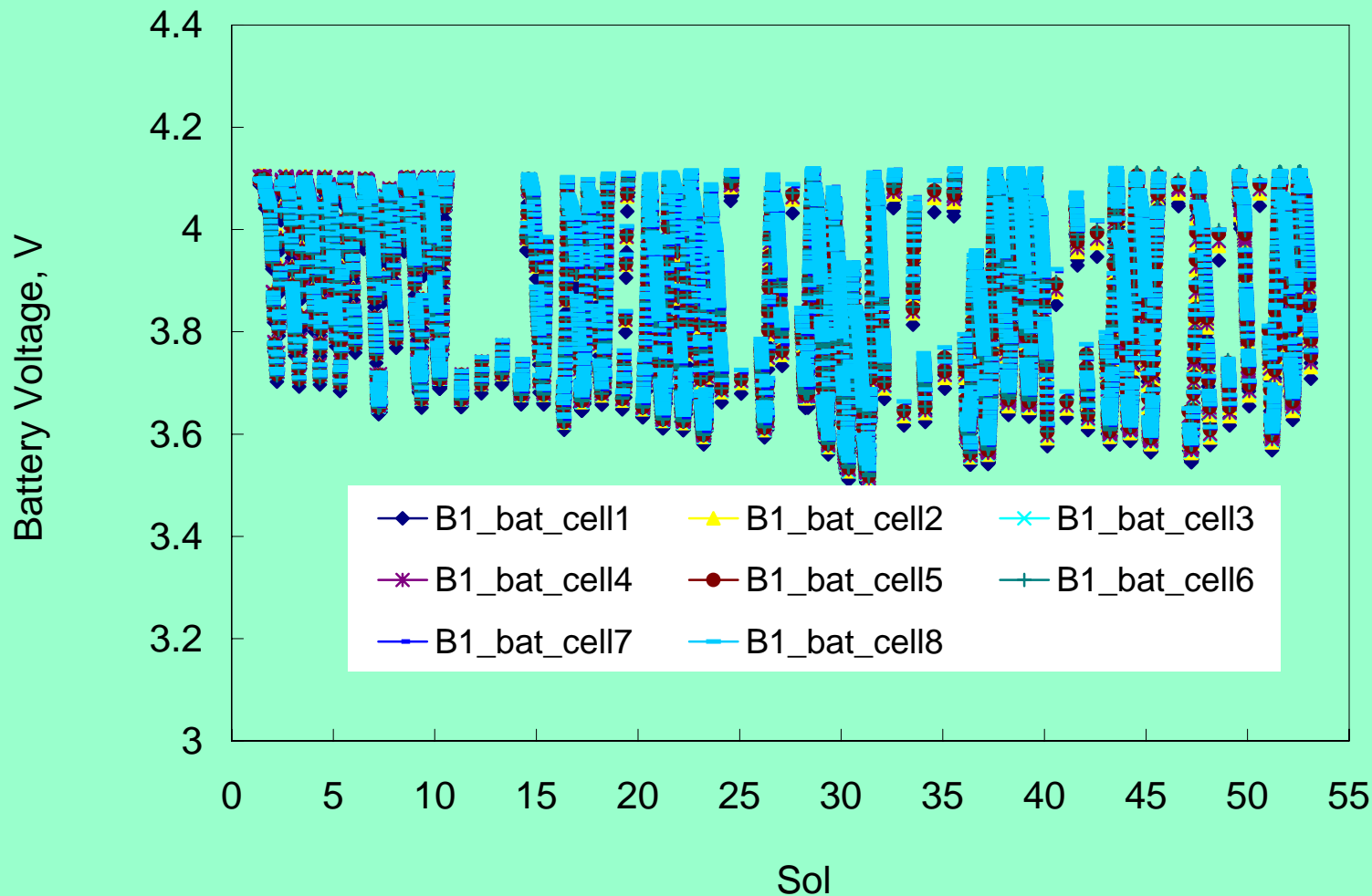

- Minimum cell voltage : 3.55 V, about 50 mV lower than on Spirit



Charge and Discharge Capacity



Mars Exploration Rover

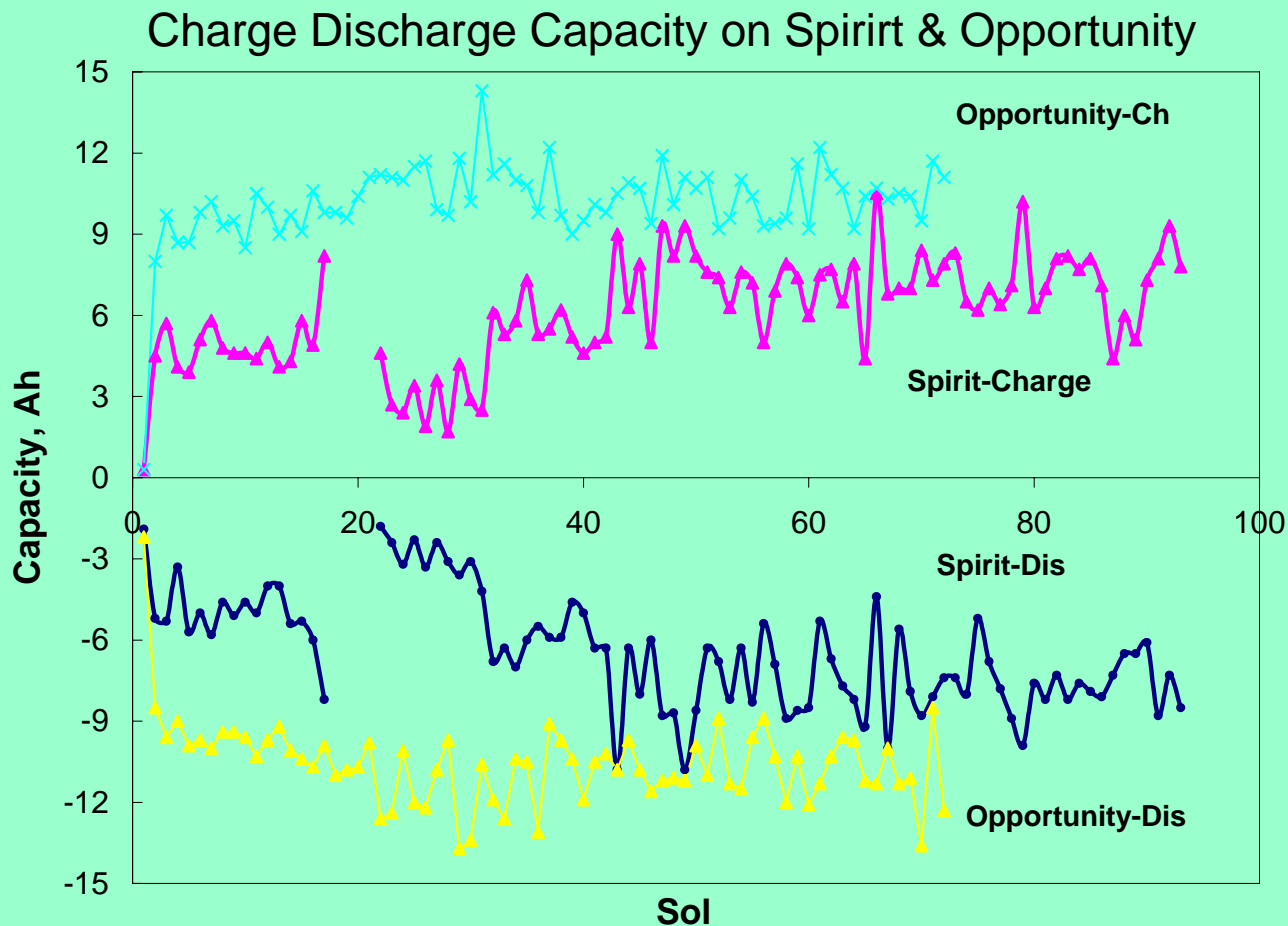

- Max discharge current is 1.6 A and the typical charge current is ~1 A.
- Depth of discharge is typically 60-70%.
- C/D ratio is close to one.
- Higher DOD on Opportunity, compared to Spirit



Cell Divergence in Rover Batteries



Mars Exploration Rover

Cell Divergence on Spirit

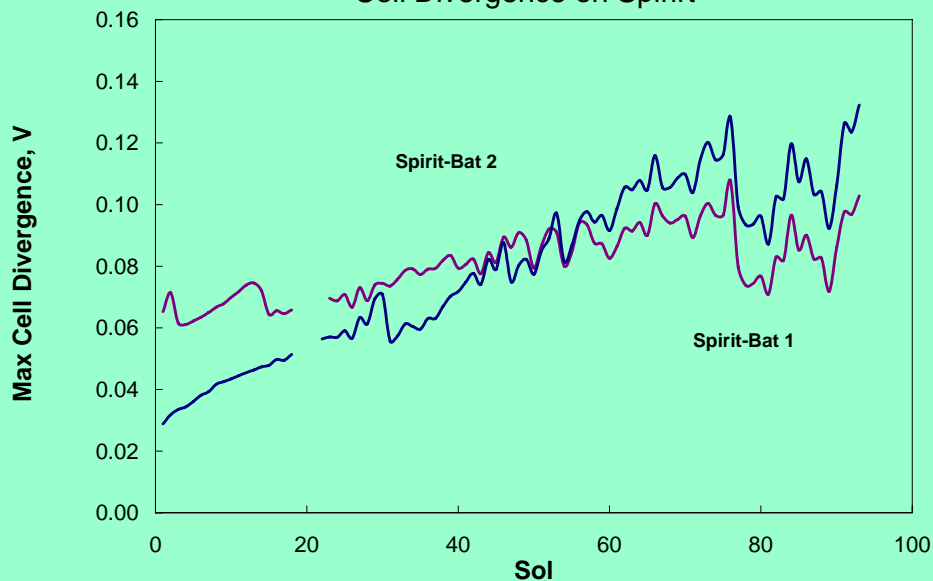

Cell Divergence on Opportunity

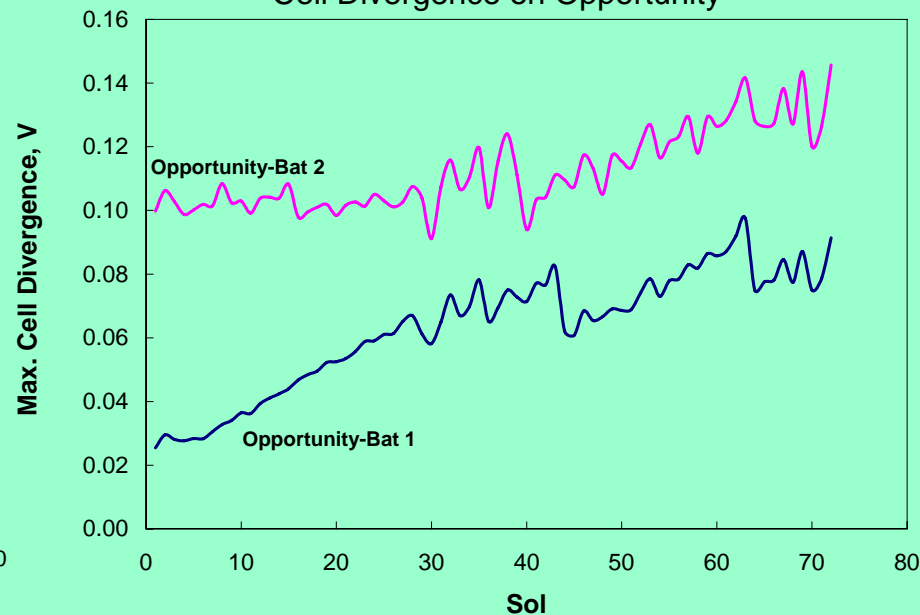

- Cell divergence increases upon cycling, almost to the extent as on Spirit.



Rover Battery Temperatures



Mars Exploration Rover

Battery Temperatures on Spirit

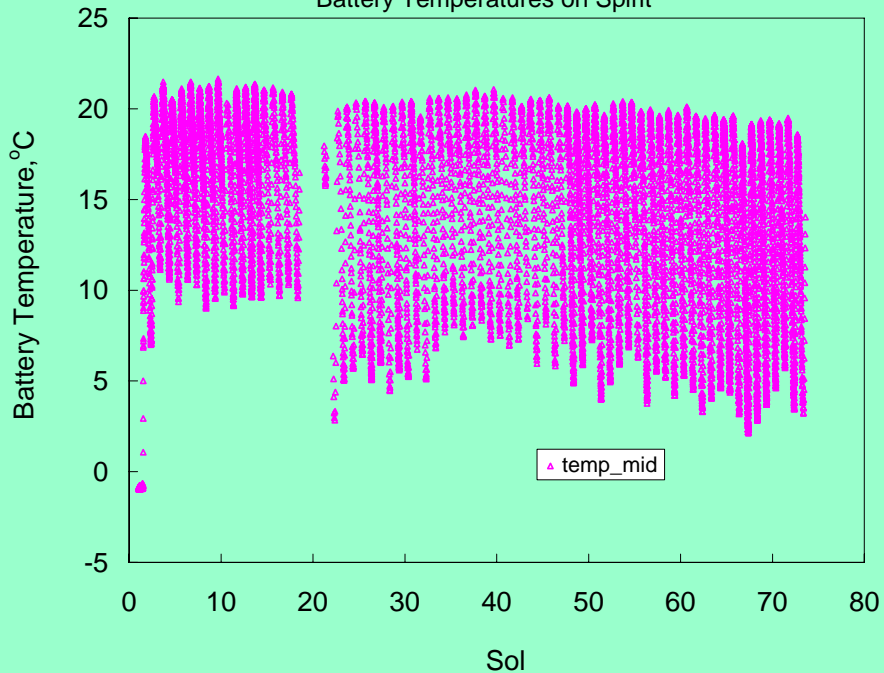

Battery Temperatures on Opportunity

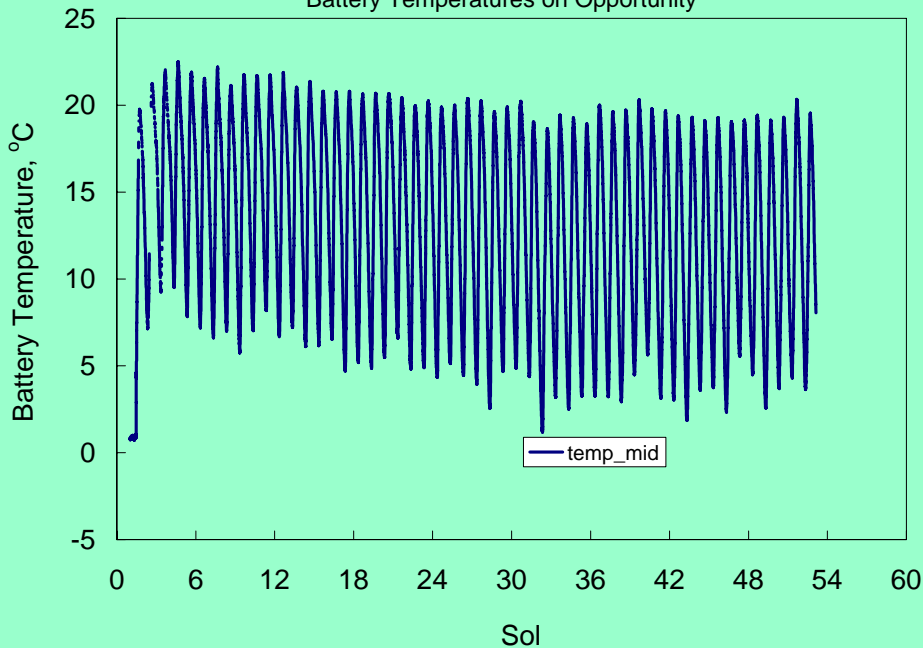

- Battery temperatures are ranging from + 5 to 22°C.
- Battery temperatures are about 1-2°C lower than on the Spirit, but about 10°C warmer than anticipated.



MER Spirit Battery Update



Mars Exploration Rover

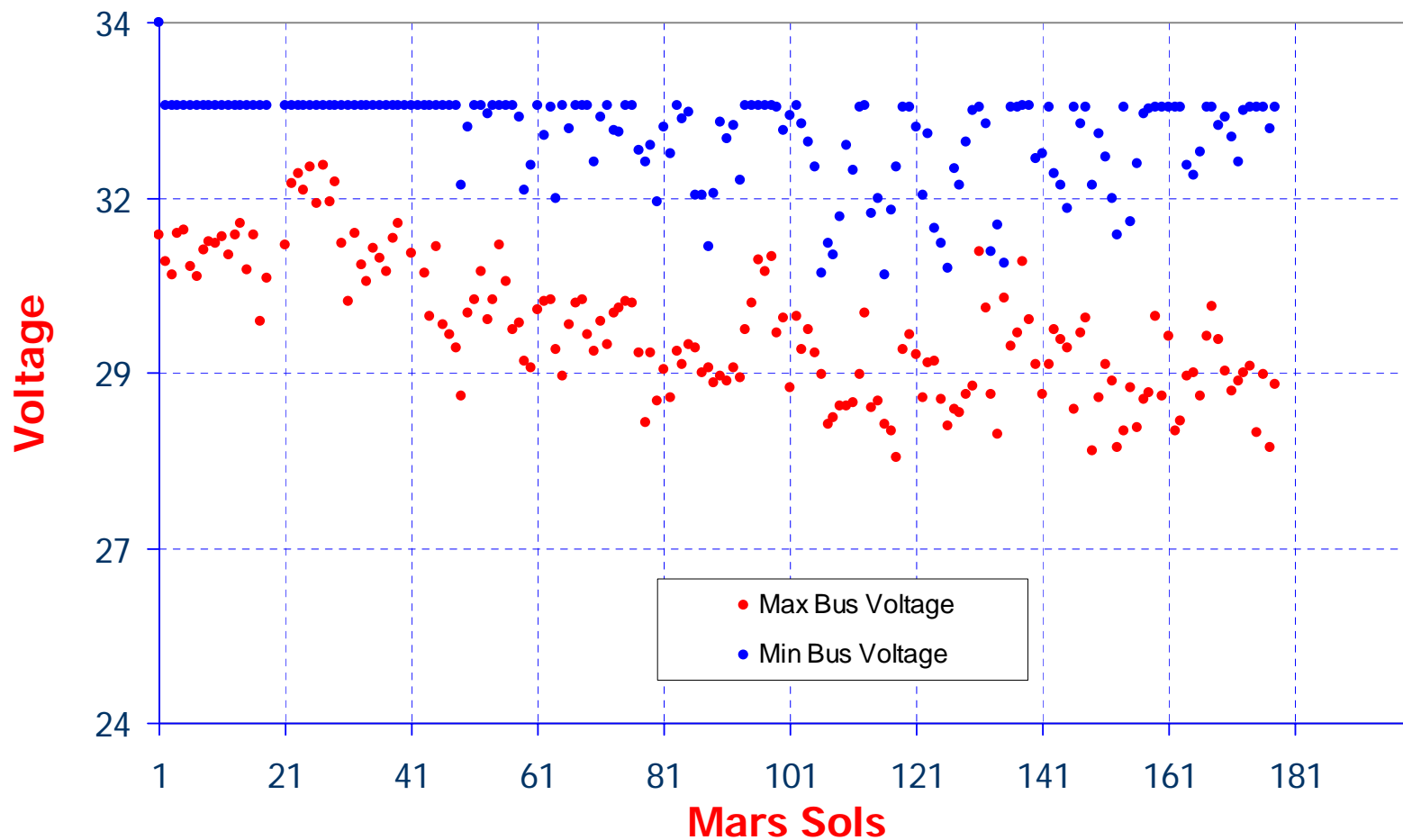



MER Opportunity Battery Update



Mars Exploration Rover

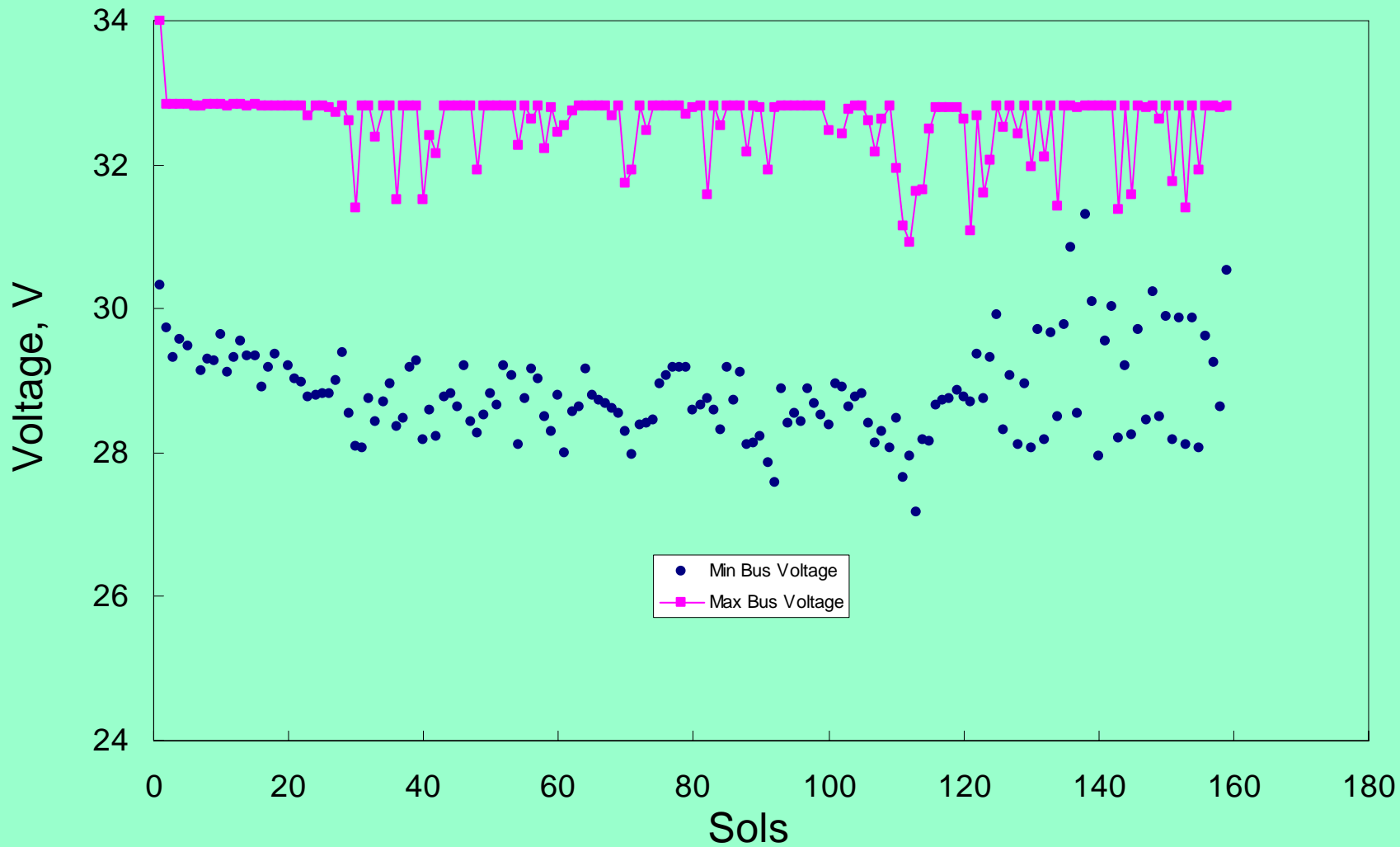



MER Battery Ground Test Predicts **JPL**

Mars Exploration Rover

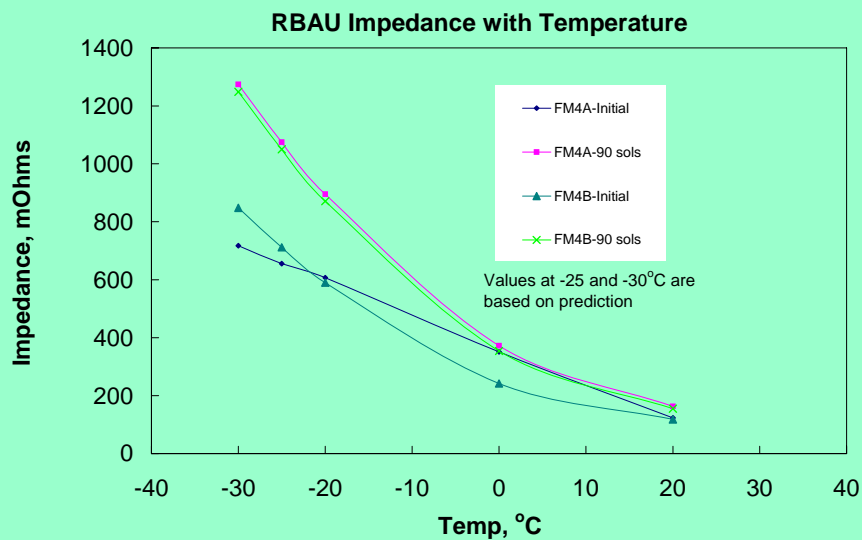

Fig. 11 Li-Ion battery impedance from ground tests

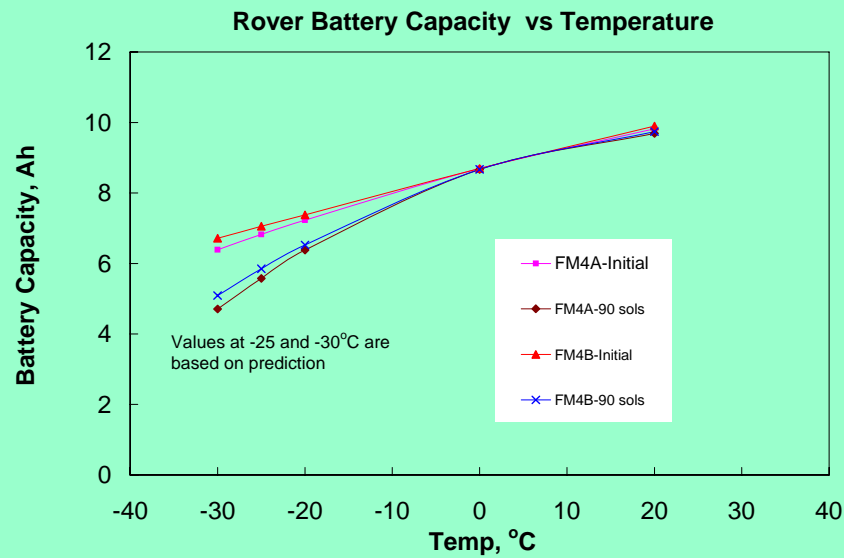

Fig. 12 Li-Ion battery impedance from ground tests



Summary



Mars Exploration Rover

- Rechargeable Lithium-ion batteries have been operating successfully on both Spirit and Opportunity rovers for the last two years, which includes six months of Assembly Launch and Test Operations (ATLO), seven months of cruise and about eleven months of surface operations.
- The Battery Control Boards designed and fabricated in-house would protect cells against overcharge and over-discharge and provide cell balance. Their performance has thus far been quite satisfactory.
- The ground data on the mission simulation battery project little capacity loss of less than 3% during cruise and 180 sols.
- Batteries are poised to extend the mission beyond six months, if not a couple of years.



Acknowledgments



Mars Exploration Rover

- The work described here was carried out at the Jet Propulsion Laboratory (JPL), California Institute of Technology, under contract with the National Aeronautics and Space Administration (NASA) and was supported by NASA Mars Exploration Rover Project.