



COVER SHEET

Access 5 Project Deliverable

Deliverable Number: FT006

Title: Cooperative Collision Avoidance Step 1-Technology Demonstration Flight Test Report

Filename: FT006_CCA Tech Demo Flight Test Report_v0_FINAL_4.doc

Abstract: The National Aeronautics and Space Administration (NASA) Access 5 Project Office sponsored a cooperative collision avoidance flight demonstration program for unmanned aircraft systems (UAS). This flight test was accomplished between September 21st and September 27th 2005 from the Mojave Airport, Mojave, California.

The objective of these flights was to collect data for the Access 5 Cooperative Collision Avoidance (CCA) Work Package simulation effort, i.e., to gather data under select conditions to allow validation of the CCA simulation. Subsequent simulation to be verified were: Demonstrate the ability to detect cooperative traffic and provide situational awareness to the ROA pilot; Demonstrate the ability to track the detected cooperative traffic and provide position information to the ROA pilot; Demonstrate the ability to determine collision potential with detected cooperative traffic and provide notification to the ROA pilot; Demonstrate that the CCA subsystem provides information in sufficient time for the ROA pilot to initiate an evasive maneuver to avoid collision; Demonstrate an evasive maneuver that avoids collision with the threat aircraft; and lastly, Demonstrate the ability to assess the adequacy of the maneuver and determine that the collision potential has been avoided.

The Scaled Composites, LLC Proteus Optionally Piloted Vehicle (OPV) was chosen as the test platform. Proteus was manned by two on-board pilots but was also capable of being controlled from an Air Vehicle Control Station (AVCS) located on the ground. For this demonstration, Proteus was equipped with cooperative collision sensors and the required hardware and software to place the data on the downlink.

Prior to the flight phase, a detailed set of flight test scenarios were developed to address the flight test objectives. Two cooperative collision avoidance sensors were utilized for detecting aircraft in the evaluation: Traffic Alert and Collision Avoidance System-II (TCAS-II) and Automatic Dependent Surveillance Broadcast (ADS-B). A single intruder aircraft was used during all the flight testing, a NASA Gulfstream III (G-III). During the course of the testing, six geometrically different near-collision scenarios were evaluated. These six scenarios were each tested using various combinations of sensors and collision avoidance software. Of the 54 planned test points 49 were accomplished successfully. Proteus flew a total of 21.5 hours during the testing and the G-III flew 19.8 hours. The testing fully achieved all flight test objectives.

The Flight IPT performed an analysis to determine the accuracy of the simulation model used to predict the location of the host aircraft downstream during an avoidance maneuver.

The data collected by this flight program was delivered to the Access 5 Cooperative Collision Avoidance (CCA) Work Package Team who was responsible for reporting on their analysis of this flight data.

Status:

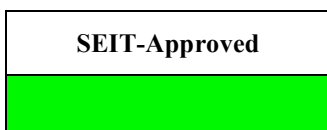

Limitations on use: This document represents thoughts and ideas of the Flight IPT work package team. It has not been reviewed or approved as an Access 5 project position on this subject.



NASA ACCESS 5

Cooperative Collision Avoidance Step 1-Technology Demonstration Flight Test Report

Revision 1

24 March 2006

NICHOLAS A. TRONGALE
Access 5 Flight IPT Lead

iii

The following document was prepared by a collaborative team through the noted work package. This was a funded effort under the Access 5 Project.

1.0 EXECUTIVE SUMMARY

The National Aeronautics and Space Administration (NASA) Access 5 Project Office sponsored a cooperative collision avoidance flight demonstration program for unmanned aircraft systems (UAS). This flight test was accomplished between September 13th and September 26th 2005 from the Mojave Airport, Mojave California.

The objective of these flights was to collect data for the Access 5 Cooperative Collision Avoidance Work Package simulation effort. The Scaled Composites, LLC Proteus Optionally Piloted Vehicle (OPV) was chosen as the test platform. Proteus was manned by two on-board pilots but was also capable of being controlled from a Air Vehicle Control Station (AVCS) located on the ground. For this demonstration, Proteus was equipped with cooperative collision sensors and the required hardware and software to place the data on the downlink.

Prior to the flight phase, a detailed set of flight test scenarios were developed to address the flight test objectives. Two cooperative collision avoidance sensors were utilized for detecting aircraft in the evaluation: Traffic Alert and Collision Avoidance System-II (TCAS-II) and Automatic Dependent Surveillance Broadcast (ADS-B). A single intruder aircraft was used during all the flight testing, a NASA Gulfstream III (G-III). During the course of the testing, six geometrically different near-collision scenarios were evaluated. These six scenarios were each tested using various combinations of sensors and collision avoidance software. Of the 54 planned test points 49 were accomplished successfully. Proteus flew a total of 21.5 hours during the testing and the G-III flew 19.8 hours. The testing fully achieved all flight test objectives.

A questionnaire was developed prior to the test and used to gain insight into the human interface of the UAS pilot with the system. After each test run, the UAS pilot was asked a series of questions designed to document the pilot's response to the collision displays and his ability to maintain situational awareness during the scenario.

The Flight IPT will perform an analysis to determine the accuracy of the simulation model used to predict the location of the host aircraft downstream during an avoidance maneuver. The results of this analysis will be included in the technical report to be published later this month.

The data collected by this flight program will be delivered to the Access 5 Cooperative Collision Avoidance (CCA) Work Package. The CCA work package is responsible for reporting on their analysis of this flight data.

TABLE OF CONTENTS

1.0 EXECUTIVE SUMMARY	IV
2.0 INTRODUCTION.....	1
2.1 GENERAL	1
2.2 BACKGROUND.....	1
3.0 OBJECTIVE.....	2
4.0 TEST ITEM	
DESCRIPTION.....	3
4.1 TEST ARTICLE.....	4
4.1.1 <i>Host Aircraft</i>	4
4.1.1.1 <i>Proteus Test Equipment</i>	4
4.1.1.2 <i>Proteus Antenna Locations</i>	5
4.1.2 <i>Air Vehicle Control Station</i>	7
4.1.3 <i>Intruder Aircraft</i>	10
4.1.3.1 <i>Gulfstream III Test Equipment</i>	11
5.0 SIMULATION.....	11
5.1 OVERVIEW	11
5.2 PRE-FLIGHT SIMULATION	11
5.3 RESULTS	12
6.0 FLIGHT TESTING.....	12
6.1 OVERVIEW	12
7.0 DATA.....	15
7.1 PROTEUS AIRBORNE AND GROUND RECORDER DATA	15
7.2 COMMON TOOL DATA	16
7.3 AVCS OPERATOR VIDEO	16
7.4 G-III DATA	16
7.5 HSI QUESTIONNAIRE.....	16
7.6 SCRIBE NOTES.....	16
7.7 PARAMETER LIST.....	17
8.0 LESSONS LEARNED	17
9.0 APPENDICES.....	21

2.0 INTRODUCTION

2.1 General

Access 5 is a national project to promote the safe and reliable utilization of unmanned aircraft systems (UAS) for defense, civil, and commercial applications. The goal of the project is to achieve routine access to the National Airspace System (NAS) for high altitude, long endurance (HALE) UAS in five years. The goal of Step 1 of Access 5 is to establish requirements for flight operations above FL430 in the NAS and demonstrate the capabilities necessary to achieve these requirements using cooperative collision avoidance (CCA) technologies.

2.2 Background

Due to the rapid advancement in HALE UAS technology spearheaded by the Department of Defense (DOD) and the National Aeronautics and Space Administration (NASA) investments, both industry and government have developed a need for routine access to the national airspace in order to fulfill their missions or meet a perceived commercial demand. DOD increasingly requires UAS presence in the national airspace for training and repositioning of assets, while an emerging national security need is to provide border and port protection, and continuous oversight of key infrastructure. Demand for civil and commercial UAS services is quickly growing in the areas of science, telecommunications, resource management, and disaster management. The routine access to the NAS by UAS would result in improved national security, expansion to the U.S. economy, and increased U.S. leadership in aviation.

Certification procedures, criteria, and operating requirements that meet the Federal Aviation Administration (FAA)'s safety of flight approval have not yet been developed for any class of UAS. In addition, special subsystems that allow the unmanned aircraft to operate in the NAS without a human pilot onboard have not been fully developed and certified for use by the FAA. UAS pilots located in Air Vehicle Control Stations (AVCS) typically fly these unmanned aircraft (UA). Therefore, for UAS to operate with an "equivalent level of flight safety as that of a manned aircraft", special subsystem-piloting aides such as sense and avoid subsystems must be utilized. These subsystems are able to locate other aircraft in the surrounding airspace and provide the UAS pilot with advisory information in sufficient time for the UAS pilot to maneuver the UA and avoid a potential collision.

There are two essential types of airborne flight objects that must ultimately be detected: *cooperative and non-cooperative*. Cooperative aircraft, which comprise most of the total air traffic, are those aircraft that transmit a signal from their onboard Mode A, C, or S transponder or datalink transceiver.

Probably the most common type of collision avoidance tool used to detect and locate cooperative aircraft is the Traffic Alert and Collision Avoidance System (TCAS), which is required on all aircraft in the United States that are capable of seating 10 or more passengers. The transponder signal from a cooperative aircraft is used by other aircraft's TCAS equipment to display that aircraft's position and altitude on a traffic display indicator in the TCAS-equipped aircraft. If the separation of TCAS equipped aircraft to other cooperative aircraft becomes a hazard, the TCAS equipment will alert the pilot(s) to the potential hazard by displaying a Traffic Advisory (TA). If

the situation is allowed to worsen, the TCAS equipment generates an avoidance maneuver or Resolution Advisory (RA) that directs the pilot, via the TCAS display and aural alert, to climb or descend in order to avoid a potential collision.

A newly developed technology that is designed to improve situational awareness is the Automatic Dependent Surveillance-Broadcast (ADS-B). In typical applications, the ADS-B equipped aircraft uses a Global Positioning System (GPS) receiver to derive its precise position from the GPS constellation of satellites, and then combines that position with additional aircraft data, such as speed, heading, altitude and whether the aircraft is turning, climbing or descending. This information is then simultaneously broadcast via a digital datalink or Universal Access Transceiver (UAT) to other ADS-B capable aircraft and to ADS-B ground communication transceivers which relay the aircraft's position and the additional information to Air Traffic Control centers in real time. Other ADS-B equipped aircraft and ground stations within about 150 miles receive the UAT broadcasts and display the information on a computer screen. Pilots see the traffic on a Cockpit Display of Traffic Information (CDTI) display. Controllers on the ground can see the ADS-B targets on their regular traffic display screen, along with pure radar targets.

Many small general-aviation airplanes, as well as all gliders and balloons, with very few exceptions, are not equipped with any transponder or transceiver. These aircraft are categorized as non-cooperative aircraft.

This flight demonstration was focused on using cooperative technologies onboard the UAS during HALE flight.

This report describes the flights conducted in the Isabella MOA between 21 September 2005 and 28 September 2005 under the Access 5 Step 1 Cooperative Collision Avoidance Test Plan dated 12 Aug 2005. 6 flights were flown, totaling 21.5 hours.

3.0 OBJECTIVE

The objective of this flight test was to collect data to validate the CCA simulation. Figure 1 illustrates the points in the functional architecture at which data was collected. Sufficient data was collected to consider this objective fully met.

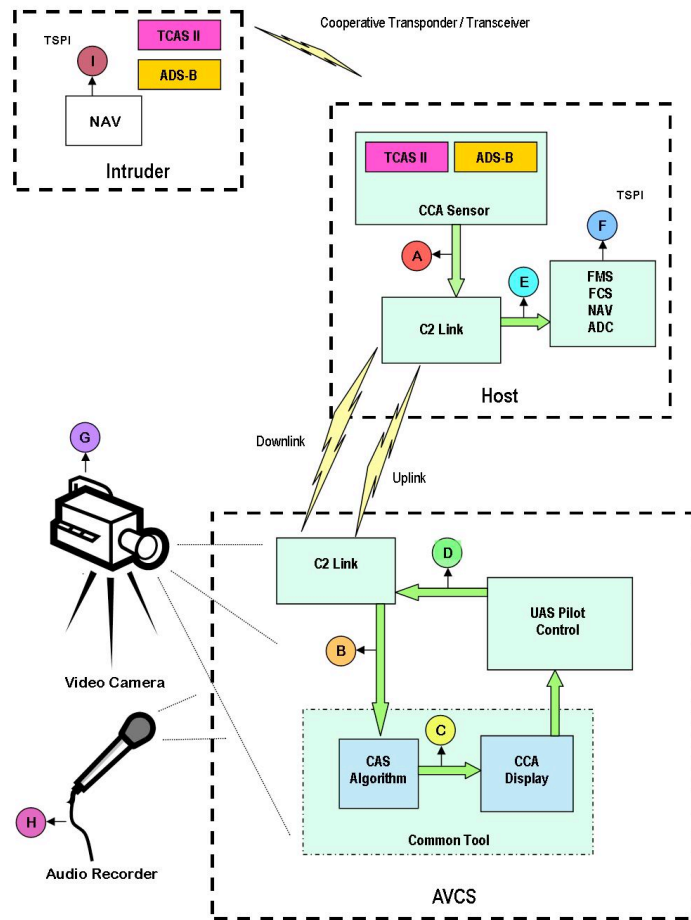

Figure 1
Data Collection Points

4.0 TEST ITEM DESCRIPTION

Access 5 CCA Step 1 Technology Demonstration consisted of the Scaled Composites, LLC (SCI) Proteus Optionally Piloted Vehicle (OPV) with TCAS II and ADS-B sensors providing position information, and a Air Vehicle Control Station (AVCS) equipped with the Access 5 Common Tool and with datalink delay insertion software/equipment. The Access 5 Common Tool, a laptop computer with unique application software, contained the collision avoidance system (CAS) algorithm and provided the collision avoidance display.

Overall, the host vehicle (Proteus) used the installed sensors to detect and track intruder aircraft. This data was transmitted to the AVCS where a computer algorithm identified minimum distances and determined if an avoidance maneuver was required. If needed, an alert was generated for the UAS pilot via a display. The UAS pilot then performed the required avoidance maneuver through control commands sent to the test vehicle. The host vehicle maneuvered to

avoid the conflict. Lastly the onboard sensors transmitted data that the pilot used to determine when the avoidance maneuver was complete and if it was successful.¹

Three different test architectures were demonstrated. 1) ADS-B sensors were used to determine the positions of the UA and intruder aircraft. That information was datalinked to the AVCS, where the CAS algorithm in the Common Tool (CT) determined if an avoidance maneuver was required, alerted the pilot and displayed an avoidance maneuver on the CA display for the pilot to follow. 2) TCAS sensors were used to determine UA and intruder relative position, datalink the data to the AVCS and the CT CAS algorithm was used to generate the required alerts and display an avoidance maneuver on the CA display for the pilot to follow. 3) The TCAS II system to include the FAA approved TCAS CAS algorithm, was used to generate the alerts on the Common Tool. The Common Tool displayed the avoidance maneuver for the pilot to follow.

4.1 TEST ARTICLE

4.1.1 Host Aircraft



Figure 2
SCI Proteus OPV

Scaled Composites provided Proteus OPV (Tail Number N281PR) equipped with TCAS-II and ADS-B subsystems (Figure 2). Proteus is a twin turboprop high altitude multi mission aircraft powered by Williams International FJ44-2E engines. It is designed to carry payloads in the 2000-pound class to altitudes above 60,000 feet and remain on station up to 14 hours.

Proteus was modified for this test by incorporating the cooperative TCAS II and the ADS-B sensor systems and software to collect sensor data and place it on the downlink. The

other equipment used during this test is standard equipment that is on the aircraft at all times. Proteus was manned during all testing with a pilot and co-pilot. These individuals had the ability to retake command of the aircraft, at any time deemed necessary. The flight crew was provided by SCI and complied with FAA regulations. However, Proteus was controlled from the ground for all test points.

4.1.1.1 Proteus Test Equipment

The Proteus OPV was modified with a TCAS-II Processor, Control Panel, Directional Antenna, VSI/TRA Display, Mode S Diversity Transponder, RCZ Transponder and a Mode S Transponder Antenna. An ADS-B processor, OMNI antenna and GPS antenna were also installed. See Appendix G for specific part numbers, serial numbers, software versions and other configuration specifics relative to each demonstration flight.

¹ See Sense-and-Avoid Equivalent Level of Safety Definition for Unmanned Aircraft Systems, Revision 9, 23 November 2004.

4.1.1.2 Proteus Antenna Locations

Specific antenna locations for the host (Proteus) are depicted in the three figures below.

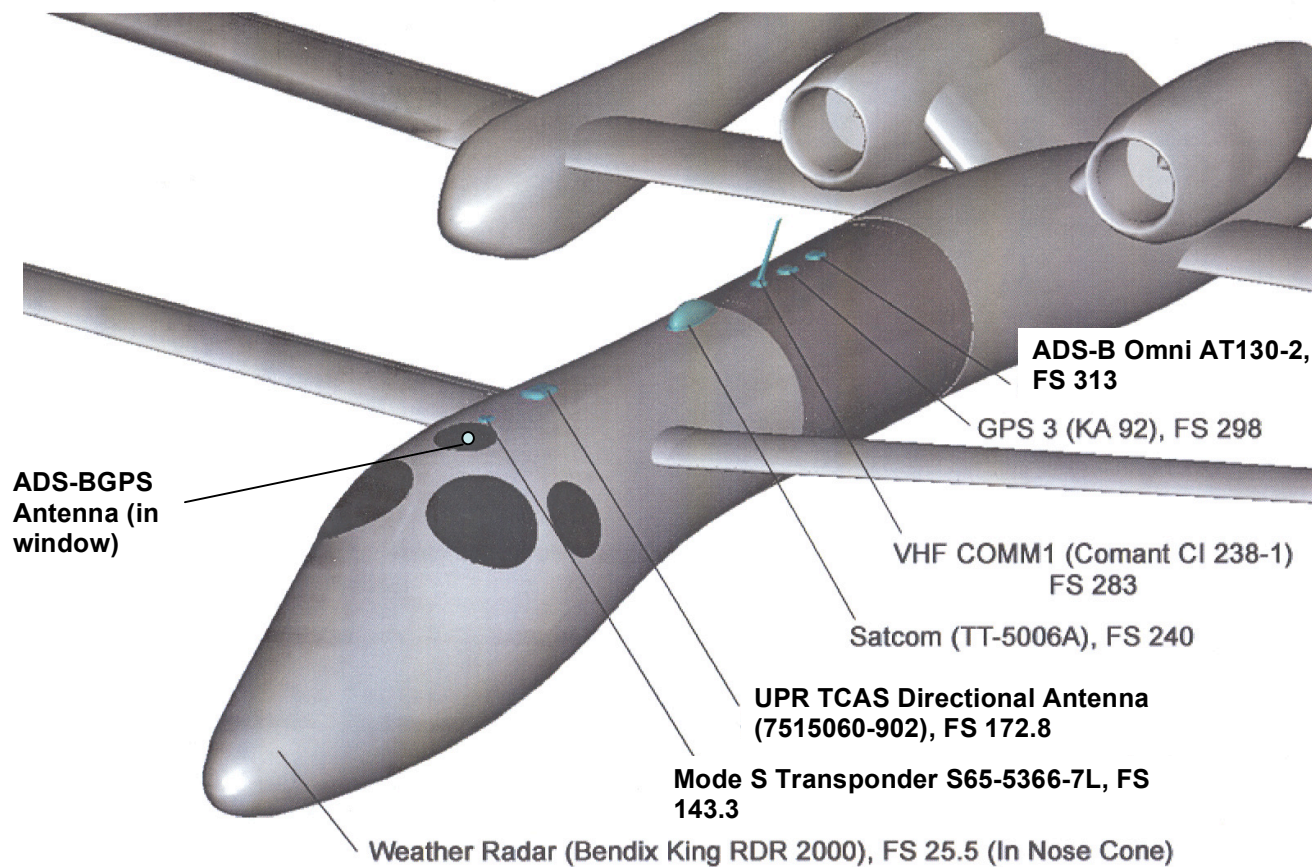

Figure 3
**Proteus Front Aspect Antenna
Locations (Top)**

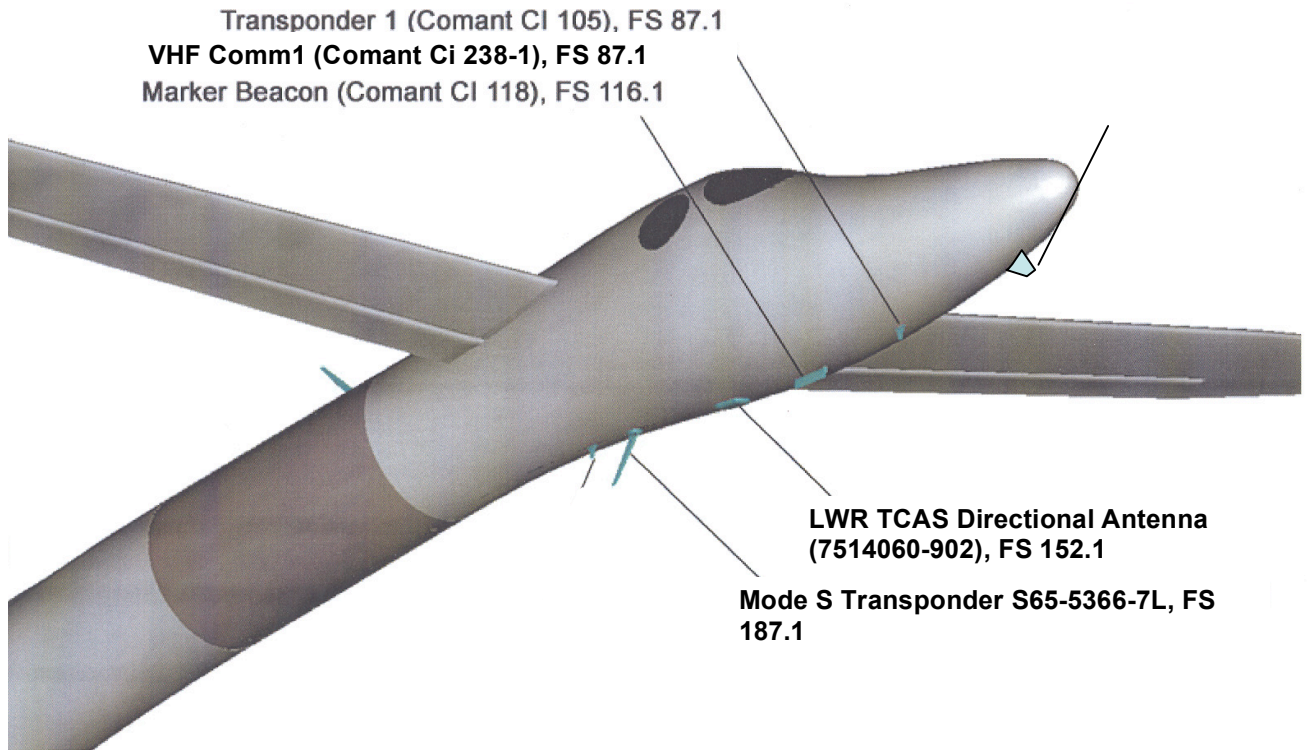

Figure 4
**Proteus Front Aspect Antenna
Locations (Bottom)**

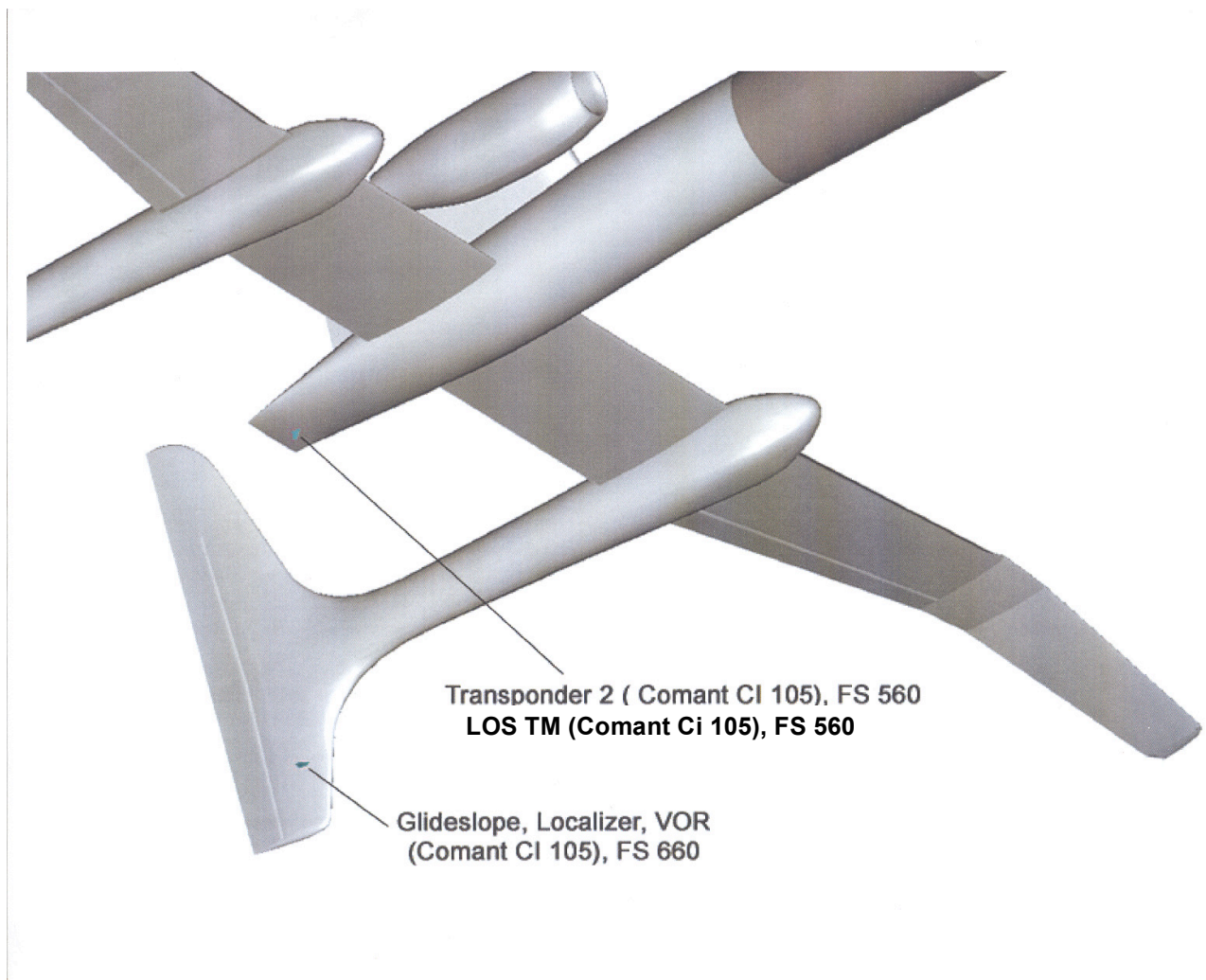
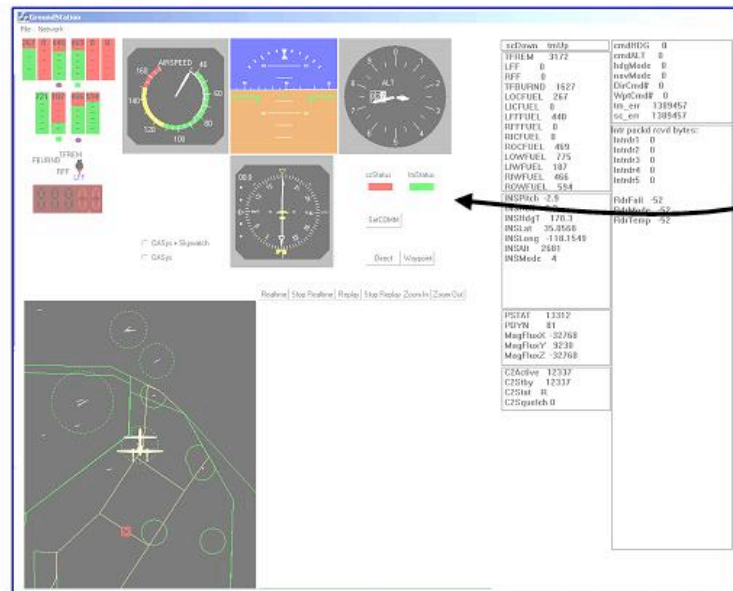

Figure 5
Proteus Rear Aspect Antenna
Locations (Bottom)

4.1.2 Air Vehicle Control Station

Proteus was controlled remotely via the Air Vehicle Control Station (AVCS). Proteus' state of health information and GPS position were provided to the UAS pilot for monitoring system-health and navigation/situational awareness, respectively. The UAS pilot had the ability to command and control Proteus from the AVCS by issuing commands that control the vehicle through the onboard flight management system. The UAS pilot was able to change the heading and altitude of the vehicle and select specific rates of climbs and descents through keyboard and mouse inputs.



Proteus avionics and state-of-health data

GPS moving map showing Proteus' position.

Figure 6
SCI Proteus UAS Pilot Station Display

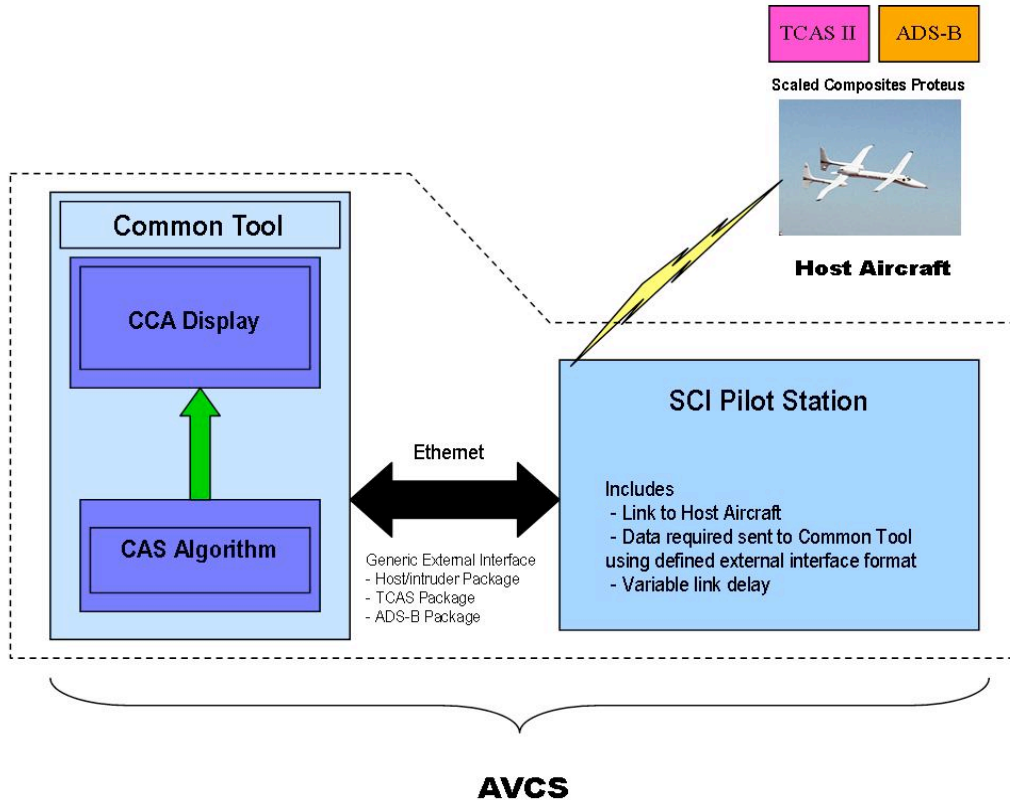

Figure 7
Air Vehicle Control Station Architecture

For this test, the AVCS was modified to interface with the CAS algorithm and the CCA display, both provided by the Common Tool. The AVCS provided the Common Tool with sensor data from the Proteus downlink. The CCA display was designed to mimic the TCAS-II vertical speed indicator (VSI) display and to provide the UAS pilot with aural and visual maneuver advisories whenever the CAS algorithm determined a maneuver was necessary.

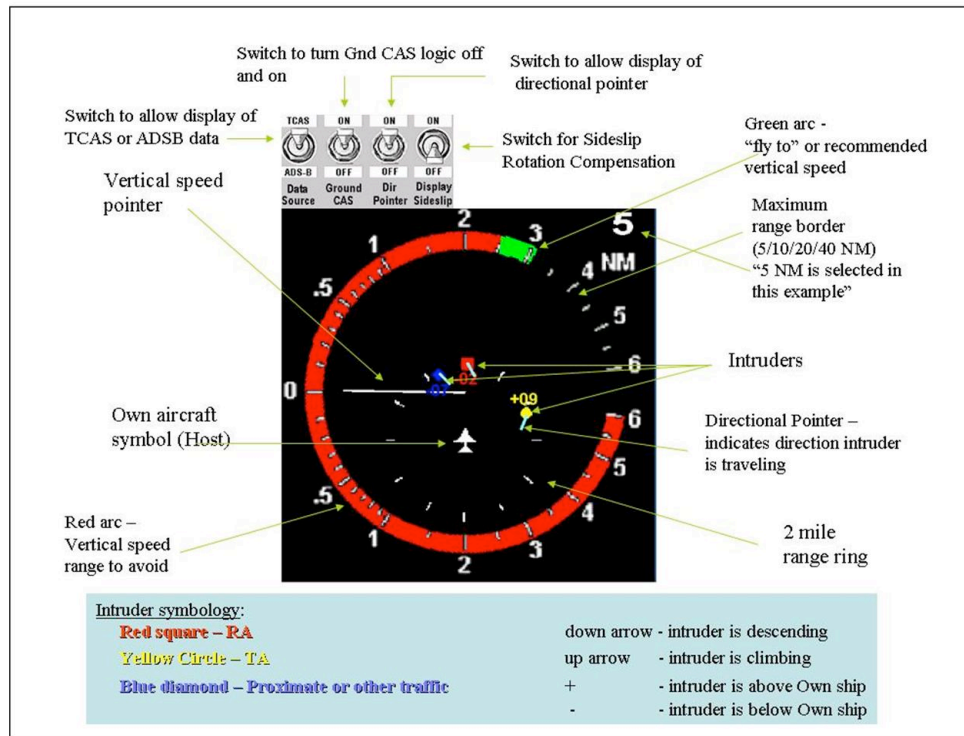

Figure 8
Common Tool CCA Display

The AVCS included a base-station radio that can be used to talk directly with the test participants on SCI's VHF test frequencies (123.375 Primary, 123.45 Secondary) as well as space for a limited number of test observers. The AVCS was located at the SCI facilities in Mojave, CA.

4.1.3 Intruder Aircraft

The intruder aircraft was chosen to represent the cruise speed that the majority of the aircraft that operate above FL430 use. NASA Dryden provided a Gulfstream III (G III) (Figure 9) for these tests. A Garmin GDL 90 Universal Access Transceiver (UAT) for ADS-B was added to the G-III, and no special software was required. This aircraft was manned by NASA personnel and flown in accordance with FAA and NASA regulations.



Figure 9
NASA Intruder Vehicle

4.1.3.1 Gulfstream III Test Equipment

NASA's G-III was equipped with TCAS-II processor, control panel, transponder and antennas. An ADS-B Processor, was installed and integrated with existing omni and GPS antennas in support of the test. See Appendix G for specific part numbers, serial numbers, software versions and other configuration specifics relative to each demonstration flight.

5.0 SIMULATION

5.1 OVERVIEW

The Common Tool (CT), a customizable situational awareness display, developed by Access 5, provided the flexibility and mobility to insert display applications or provide simulations of many different platforms into multiple test environments. The primary purpose of the common tool for this flight technology demonstration was to communicate with the Proteus ground station and display TCAS and ADS-B information to the operator.

The common tool included a generic aircraft model that could be tailored to match the performance parameters of a given aircraft as well as a simple intruder position model. The intruder position model information can be fed to the CCA display to simulate an intruder target while the generic model is running. The display issues maneuver advisories from the CAS algorithm and the operator can command a climb or dive maneuver in response to those advisories.

5.2 PRE-FLIGHT SIMULATION

Several simulation sessions using the generic vehicle model in the common tool were performed prior to the tech demo flights to aid in test planning. Each of the test plan scenarios was run several times with each release of the common tool (starting with common tool release 4.0) to demonstrate run consistency. With common tool 4.0, each scenario (except scenario 3) was run at least 10 times. With common tool 4.1 and 4.2, each scenario was run at least 5 times. After the common tool 4.2 runs, the minimum separation distance and the time of the maneuver advisory were averaged for each scenario. The maneuver advisory time was very consistent run to run, but

the minimum separation distance was quite variable due to variability in the operator response to the maneuver advisories. The maneuver advisory (climb or dive) was included in the test cards as the expected maneuver, while the warning time and minimum separation distance were used as a check on the test team's safety planning efforts. Since the generic model will not be validated until after the flights, these results (especially the minimum separation distance) could not be used as truth data.

5.3 RESULTS

Some enhancements were made to the common tool as a result of this simulation activity. Among those enhancements are the ability to set climb and dive rates in the intruder model and the layout of the CCA display.

The common tool simulation will be compared with flight data to validate the generic model tailored to match Proteus performance. The results of this comparison will be included in the technical report to be released by the Flight IPT in December 2005.

6.0 FLIGHT TESTING

6.1 OVERVIEW

Flight tests were executed in accordance with the NASA Access 5 Cooperative Collision Avoidance Step 1 Technology Demonstration Flight Test Plan, Revision 1.5, dated 11 August 2005.

Although Access 5 Step 1 activities are focused on obtaining access to the NAS above FL 430, the CCA flight demonstrations were planned at a test altitude of 15,000 feet. This altitude was chosen for two reasons, the primary reason being test efficiency (no flight hours were expended getting to altitude), the secondary reason being to allow sufficient margin for the intruder to execute the desired collision scenarios at FL 430. The choice of 15,000 feet also had the advantage of allowing the test to be executed above the Inyokern Transit Area (an area of busy airline traffic) and below Class A airspace.

Proteus's test airspeed (110 KIAS) was chosen to be in the heart of Proteus's speed envelope at 15,000 feet. The intruder speed (300 KIAS) was then tailored to match the closure rates between a HALE aircraft and the airline traffic that would typically be seen at FL 430 while staying inside the G-III speed operating envelope. The co-heading scenarios featured a closure rate of 247 KTAS while the head-on scenarios featured a closure rate of 533 KTAS.

Each scenario had a 300-foot altitude separation buffer built into the intruder aircraft's flight path for safety concerns. The intruder aircraft would fly low to improve G-III pilot visibility.

For safety precautions, the test procedures also provided explicit instructions for the test pilots to react appropriately in the event of an ABORT situation. During an ABORT the onboard Proteus pilots would assume control of Proteus and both aircraft would execute specific instructions in

accordance with that test card². Any test participant, on the ground or in the air had the authority to call an ABORT in the interest of safety.

Because no other external aids such as radar tracking, were available to aid in separation and situational control of the airborne participants, procedural control through radio procedures was paramount to mission success. Detailed test run procedures were developed that emphasized specific radio transmissions and placed in the test card deck. All participants were briefed on these procedures due to their criticality³. The Test Conductor was responsible for ensuring these radio procedures were maintained.

The tests were flown under visual meteorological conditions (VMC) inside the boundaries of the Isabella Military Operating Airspace (MOA). Joshua Control provided active radar monitoring and alerted the participants if non-participating aircraft came within 2000 feet or 5 miles of the test aircraft. Detailed planning was required in order to ensure safety and to generate the near-collision geometry scenarios required for the test. A strict set of mission rules was developed with these aims in mind. A great deal of time and effort went into the establishment of ABORT procedures. These were designed to be as consistent as possible yet still remain as effective as possible. These procedures were drawn pictorially on each test card and briefed prior to each run by the Test Conductor⁴.

NASA aircraft and personnel operated out of Edwards AFB. SCI aircraft, the AVCS, and SCI personnel operated out of Mojave Airport. Figure 10 shows the working airspace and the navigational points used to set up the test scenarios.

² See test cards at Appendix J

³ See Test Run Procedure in Test Cards at Appendix J

⁴ See Test Conduct in Test Cards at Appendix J

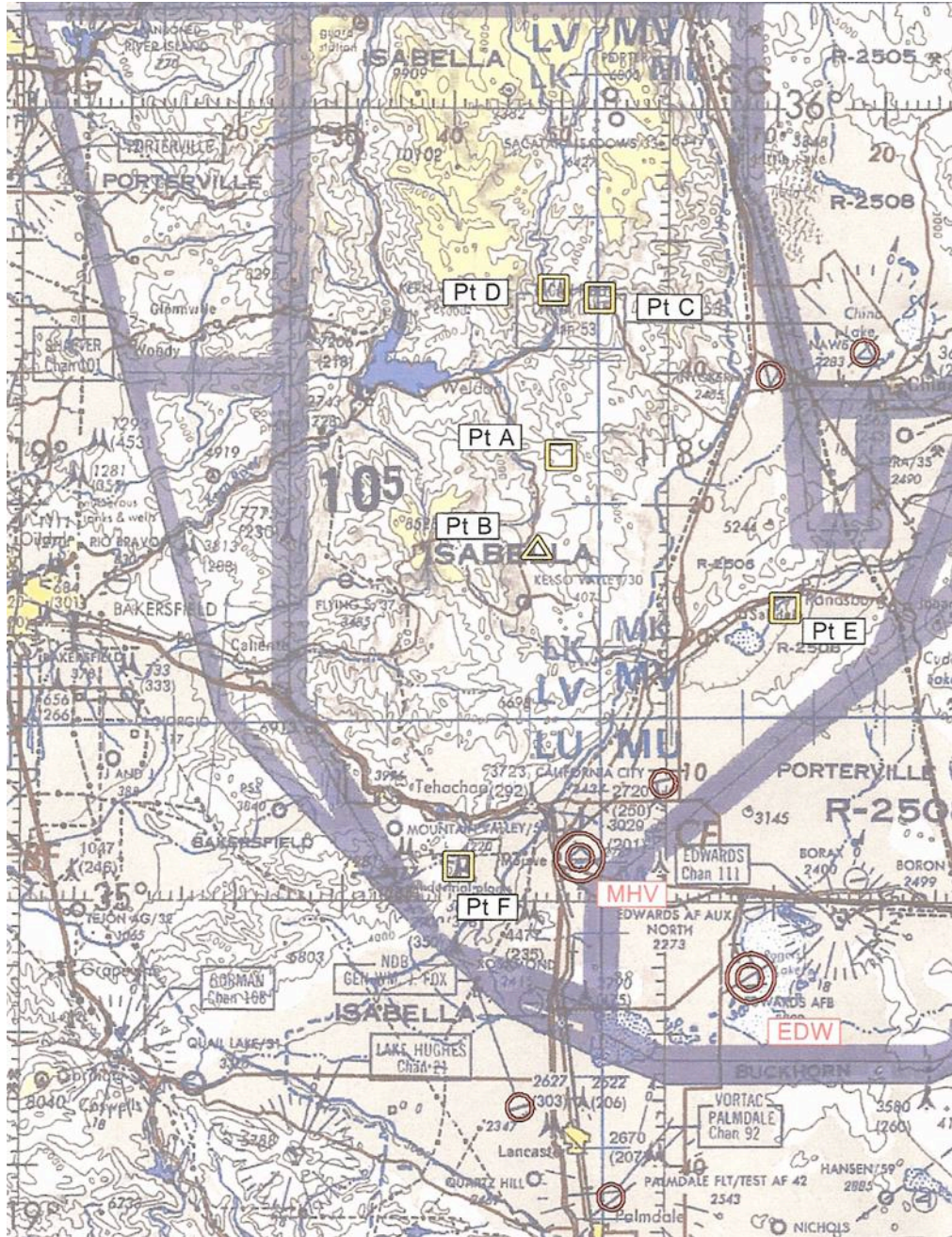

Figure 10
Test Area

Substantial effort was required to bring together the required equipment and software from multiple vendors, suppliers, and team members in order to bring this demonstration to completion. Some of the issues involved interfacing with proprietary software code as well as hardware installation in the host aircraft. During the integration phase, Proteus flew five sorties while the G-III flew one sortie. An additional two checkout sorties were flown mid-test to investigate a problem with the C2 link and to verify a change to the CAS algorithm.

The following document was prepared by a collaborative team through the noted work package. This was a funded effort under the Access 5 Project.

The demonstration flights fully satisfied the test objective; however, many difficulties were encountered including unacceptable weather, C2 problems, intruder launch delays, and merge timing issues. These difficulties caused a presumably conservative estimate of three successful test points per flight hour to be more accurate than anticipated.

Proteus flew a total of 21.5 demonstration flight hours and the G-III flew a total of 19.8 demonstration flight hours.

Seventy two total data passes were flown. Fifty-three of the fifty-four test points were attempted and forty-nine of the fifty-four test points were accomplished successfully. Additionally, 6 runs were accomplished twice – once each with different versions of the Common Tool and CAS algorithm.

Forty-five of the seventy-two passes included an avoidance maneuver through the point of closest approach of the two aircraft.

The flight log, test point log, and quick look flight reports are all included as appendices to this report.

In accordance with the Configuration Control Plan, Anomaly Reports were generated to document anomalies during the course of the test. Throughout the Checkout and Demonstration Flight phases, 17 Anomaly Reports were generated. The anomalies reported are categorized below:

- 3 test enhancements/common tool capability upgrades
- 3 anomalies having to do with C2 dropouts caused by interference
- 4 display enhancements
- 1 documenting a discrepancy between the software and the documentation
- 1 documenting inconsistent engineering units
- 1 documenting an inconsistency in the altitude sent to the CAS algorithm
- 2 documenting problems found during checkout that were fixed during that phase
- 2 documenting possible anomalies in the CAS algorithm and the common tool generic model that will be examined during data analysis.

The anomaly reports are included in Appendix K to this report.

7.0 DATA

Data processing is underway and several data sets have been delivered to the CCA work package already with the remainder scheduled to be delivered by 9 December, 2005. The data available is shown below. The following sections describe the data sets.

7.1 PROTEUS AIRBORNE AND GROUND RECORDER DATA

Proteus Airborne and Ground Recorder data are provided in text files. Each file contains data for

The following document was prepared by a collaborative team through the noted work package. This was a funded effort under the Access 5 Project.

one flight. The files are arranged in folders by Proteus flight number. The data is in engineering units and is both tab and space-delimited. Most files are too large to be imported directly into Excel. Parameter lists which include a brief description of each parameter recorded and the applicable engineering units are included in the folder of the first flight to which the list applied. The parameter lists changed after the first flight, but remained constant for the remainder of the flights. For questions regarding Proteus data, contact Mike Alsbury of Scaled Composites at (661) 824-6388.

7.2 COMMON TOOL DATA

Common Tool data is provided in text files. Each file contains data for one testpoint. The files are arranged in folders by Access 5 flight number. The data is in engineering units and is both tab and space-delimited. Most files are small enough to be imported to Excel directly. Parameters other than those requested in the parameter list may be provided. The files can be “played back” on the common tool, but they do not contain enough information to drive the Collision Avoidance display with complete information during the playback. For questions regarding Common Tool Data, contact Russell Turner of Lockheed Martin Aeronautics Company at (817) 935-4355.

7.3 AVCS OPERATOR VIDEO

A video recorder was set up behind the AVCS operator in an attempt to capture video of the operator and both the AVCS and Collision Avoidance displays. The video is not time-stamped. Audio is ambient only and is of poor quality. For the first flight, the video was allowed to run throughout the entire flight, however, the recorder sometimes turned itself off and since there was no obvious alert to either this condition or to when the recorder needed a new tape, much of the flight was probably not captured. After the first flight, the Flight IPT Lead and the Test Conductor tag-teamed the video recorder and attempted to turn it on at the beginning of each testpoint and off at the end of each testpoint. There is no indication of time or testpoint on the tape. Some flights required multiple tapes. For questions regarding the AVCS Operator Video, contact CJ Bixby of NASA Dryden Flight Research Center at (661) 276-3394.

7.4 G-III DATA

G-III data is provided in text files. Each file contains data for one parameter during one flight. The files are arranged in folders by G-III flight number. The data is in engineering units and does not contain carriage returns. For questions regarding the G-III data, contact Richard Hang of NASA Dryden Flight Research Center at (661) 276-2090.

7.5 HSI QUESTIONNAIRE

The HSI questionnaire was administered to the AVCS operator at the first successful conclusion of each test point. The questionnaire was administered only once per test point, i.e., it was not administered on repeats. At the conclusion of a test point, the scribe queried the AVCS operator and recorded the response on the questionnaire matrix. A typed version of the matrix is available in appendix F to this report.

7.6 SCRIBE NOTES

The official record of test events is contained in the scribe notes (Appendix I). The control room at Scaled Composites did not offer a time display that was visible to all participants. Effort was made to synchronize various clocks and watches available to the test team to aircraft time and those efforts were usually accurate to within a second. The time recorded in the scribe notes is local time. The terms “yellow warning” and “red warning” refer to states of the CCA display in which the host aircraft symbol turns yellow to indicate a possible traffic conflict and red to indicate that an avoidance maneuver should be executed. The term “all clear” refers to a state of the CCA display in which an aural announcement is made when the host is clear of a previous traffic conflict. The terms “climb climb” and “descend descend” refer to aural warnings made by the CCA display to coincide with a visual maneuver advisory. The scribe notes are included as an appendix to this report. Questions regarding the scribe notes should be directed to Jon Bachman of Modern Technology Solutions, Inc. (MTSI) at (505) 430 9724.

7.7 PARAMETER LIST

The final parameter list is included in Appendix C to this report. The parameter list contains the following data: Signal Number; Recorded at; Signal Name; Flight Management Systems (FMS) ID; Description; Source of Reference; Units; Dimensions; Format; Type; Bit Count; Resolution; Lower Bound; Upper Bound; TM Downlink Rate; Record Rate; and Required For.

8.0 LESSONS LEARNED

- **Test planners and test customers must have thorough knowledge of the test aircraft.**

Mission planning for the test was critical for the intercepts and was done without detailed knowledge of the navigational systems of the two aircraft involved. It was not discovered until after testing began that neither of the navigation systems was capable of providing time to go to the merge point in seconds and handheld GPS units had to be used in both cockpits. The test customer needs to participate in mission planning. For example, data analysis was complicated somewhat by the intruder aircraft maneuvering to cross at the merge point with the proper conditions. It would have been better if the intruder aircraft maintained a constant track that could be modeled easier in simulation.

Due to autopilot limitations, hand-flying the outbound legs were found more efficient than allowing the autopilot to fly those legs. This was assumed to be the case during the planning phase, but since the planners did not have a thorough understanding of the autopilot, was not given to the pilots as an instruction. As a consequence, this lesson was learned more than once as new pilots tried the same technique previously demonstrated not to work well.

The aircrews found that the TCAS display provided quite a bit of their awareness with regard to the position of the other aircraft. In fact, the intruder aircraft became so dependent on their display that they protested turning it off for some of the testpoints. Since it was not deemed technically necessary to turn the TCAS off for those testpoints, the Test Director allowed the intruder aircraft to keep the TCAS display on for all of the testpoints. The TCAS display should have been deemed mission-critical

equipment for this test.

- **Provide situational awareness in the control room.**

This collision avoidance demonstration was planned without the availability of many of the tools upon which the test community has come to rely. Since there was no air-to-air TACAN or radar tracking, the safety responsibility fell wholly to the crews onboard the aircraft. The control room could provide little help because situational awareness with regard to relative aircraft positions was provided by the CCA display – the very system that was under test – and through procedural tracing via timing. With these limitations, visual contact between the aircraft and coordination of time to go to the established merge point became paramount to safe execution of the test. While the tests were conducted safely, test efficiency and safety could both be enhanced by providing situational awareness in the control room.

Coordinating a specific merge point time was much more complex than readily apparent. During planning discussions with the aircrew, it was not clear which of the methods discussed was preferred. Once flight testing began, it became clear that the best method was for the control room to establish a local merge time and get concurrence from each cockpit that they could make that particular time. From that point, it was a matter of each cockpit monitoring and updating their time to go every minute. This, however, was still challenging for the pilots to accomplish when winds were high. Had the control room had some situational awareness, the test conductor could have helped the aircraft keep on schedule and, perhaps more importantly, could have clearly seen when a scenario wasn't going to work and called a knock-it-off long before either aircraft approached the merge point. This would have dramatically improved test efficiency.

Although the safety planning called for the separation responsibility to lie in the cockpit of the intruder aircraft, it was very tempting for the test team to want to put some of that responsibility in the control room. In fact, coordination of the visual contact rule was best done in the control room. However, the control room crew must diligently refuse to use the situational awareness provided by the system under test – the CCA display – to inform any safety decisions.

The visual contact rule was overly restrictive when using an OPV rather than a UAV as the host aircraft. The host aircrew often had visual on the intruder long before the intruder had visual on the host (the intruder was larger, had more contrasting paint, and its engines created visual smoke). But the rule stated that the intruder must have the host in sight to continue the run. On one occasion, a run was aborted for the 15 second rule about one second before the intruder finally gained visual contact. In that case, the host had visual on the intruder for several seconds before the run was aborted. After this incident, the rule was changed to allow the run to continue if either cockpit had visual on the other aircraft and testing continued without another abort for a lack of visual. Better real time monitoring of the participating aircraft with positive control from the control room would have been another way of

accomplishing this and may be the only safe way to accomplish this in the case where one of the participating aircraft is a UAV.

- **If situational awareness is unavailable in the control room, a very strict communication protocol must be established and adhered to.**

A mission rule was established where the intruder cockpit was required to have visual contact with the host aircraft not later than 15 seconds time to go (TTG) to the merge point, or the run must be aborted. However, due to timing errors there was the possibility of each aircraft arriving at the merge point at different times. Keeping track of this situation was complicated due to the lack of real-time monitoring in the control room. Once the intruder had visual on the host the test point would run to completion, often overshooting the merge point by many seconds. It is imperative that communication procedures be established and practiced before test flights begin to ensure that all parties understand the procedures and their necessity.

- **Consider visual enhancement of either or both aircraft depending on which aircraft is manned.**

The bottom line: Small airplanes are hard to see. Since the safety planning rested so completely on visual contact between the two aircraft, pilots with above-average vision should have been a mission requirement.

With the small size of UAVs and OPVs, some enhancement of the visual signature is recommended. During the planning phase the test team had considered implementing a smoke system on the host aircraft, but the pilots convinced the planners that smoke would not be necessary. This leads to two lessons: 1) pilots can overestimate their ability to see other aircraft and 2) visual enhancement of small aircraft is desirable.

- **Centralize interface requirements -- planners, conductors, and customers must have a consistent view of the operation.**

Interface requirements were developed in at least 3 different places (the CCA work package, the CCA equipment vendors, and the common tool developers). This information was never sufficiently integrated leading to confusion during the integration process and to last-minute changes. This could have been mitigated by either centralizing the interface requirements or allowing the Flight IPT integration team enough access to the test vehicle integration process to head off confusion.

- **Use a traditional organizational structure to get work done.**

The Access 5 program was structured to emphasize collaboration among the various organizations participating in the project. While this structure works well for planning, it hampered execution. The distribution of authority was such that although the Flight IPT was responsible for executing the flight demonstrations, it had limited authority to do so. Much of the time and effort that could have been expended on test

planning was spent establishing authority and credibility with other groups inside the project and gaining approval from the project to proceed to the next step in planning. To make matters worse, the Flight IPT was also operating in a collaborative/consensus mode for much of the time that should have been used for initial test planning. Since consensus could rarely be gained during weekly telecons with spotty individual attendance, no test planning occurred. Once the Flight IPT switched to an authoritarian mode of operation with a strong leader and individuals charged with executing and reporting back to the team, test planning got off the ground. The collaborative model should be replaced by a more traditional organization with clearly defined roles and responsibilities at the working level in order to increase efficiency and reduce schedule risk.

- **If you can't co-locate, meet often.**

The Access 5 program in general and the Flight IPT in particular consist of individuals from a number of organizations located across the country. Attempts to coordinate test planning activities remotely across the various locations were very inefficient. During telecons, only the loudest voices are heard and body language was completely lost. Face-to-face meetings where the participants dedicated a day or two to the business at hand were found to be a much more efficient means to come to a lasting consensus among participants. This was especially true during the initial stages when the personalities and strengths of each individual were unknown. Each major activity is best accomplished with a face-to-face kickoff meeting to assign roles and responsibilities followed by a final face-to-face coordination meeting to review and approve the products of that activity.

- **The test team must control the test articles.**

The Access 5 program sought to leverage assets of participating organizations to accomplish the goals of the program. While this model appears to be efficient and cost-effective, it leaves the project very vulnerable to the shifting priorities and schedules of the participating organizations. Since the project does not own the test articles (and in many cases gains access to the test articles through in-kind contributions rather than traditional contract mechanisms), the project has limited ability to guarantee the availability of test articles or expertise to advise in the use of the test articles. Contract mechanisms such as payment milestones must be in place to aid the project in keeping some control over the project schedule.

9.0 APPENDICES

The following appendices are supporting documentation to this report. If required, they can be obtained by contacting NASA DFRC. Appendices are not proprietary unless annotated as such.

- A. Test Condition Matrix
- B. Flight Log
- C. Parameter List
- D. CCA Tech Demo Summary (proprietary)
- E. Test Point Log
- F. HSI UAS Pilot Questionnaire
- G. Configuration Log
- H. Quick Look Reports
- I. Scribe Notes
- J. Flight Card
- K. Anomaly Report