

# TEM Cell Testing of Cable Noise Reduction Techniques from 2 MHz to 200 MHz – Part 1

Arthur T. Bradley<sup>#1</sup>, William C. Evans<sup>#2</sup>, Joshua L. Reed<sup>#3</sup>, Samuel K. Shimp III<sup>#4</sup>, Fred D. Fitzpatrick<sup>#5</sup>

*NASA Langley Research Center*

*5 North Dryden, MS488, Hampton, VA 23681 USA*

<sup>1</sup>arthur.t.bradley@nasa.gov

<sup>2</sup>cce032000@utdallas.edu

<sup>3</sup>jreed258@ignatius.wju.edu

<sup>4</sup>sshimp@vt.edu

<sup>5</sup>fred.d.fitzpatrick@nasa.gov

**Abstract—** This paper presents empirical results of cable noise reduction techniques as demonstrated in a TEM cell operating with radiated fields from 2 - 200 MHz. It is the first part of a two-paper series. This first paper discusses cable types and shield connections. In the second paper, the effects of load and source resistances and chassis connections are examined. For each topic, well established theories are compared to data from a real-world physical system. Finally, recommendations for minimizing cable susceptibility (and thus cable emissions) are presented.

## I. INTRODUCTION

There are numerous papers and textbooks that present theoretical analyses of cable noise reduction techniques. However, empirical data is often targeted to low frequencies (e.g. <50 KHz) or high frequencies (>100 MHz). Additionally, a comprehensive study showing the relative effects of various noise reduction techniques is needed. These include the use of dedicated return wires, twisted wiring, cable shielding, shield connections, changing load or source impedances, and implementing load- or source-to-chassis isolation.

We have created an experimental setup that emulates a real-world electrical system, while still allowing us to independently vary a host of parameters. The goal of the experiment was to determine the relative effectiveness of various noise reduction techniques when the cable is in the presence of radiated emissions from 2 MHz to 200 MHz.

## II. EXPERIMENT SETUP

The electronic system (Fig. 1) consisted of two Hammond shielded electrical enclosures, one containing the source resistance, and the other containing the load resistance. The boxes were mounted on a large aluminium plate – acting as the chassis. Cables connecting the two boxes measured 81 cm in length and were attached to the boxes using standard D38999 military-style connectors.

The test setup is shown in Fig. 2. Electromagnetic fields were created using an HP8657B signal generator, MiniCircuits ZHL-42W-SMA amplifier, and an EMCO 5103 TEM cell. Measurements were taken using an Agilent E4401B spectrum analyzer and HP1141a differential probes.



Fig. 1 Electronic system



Fig. 2 Experiment test setup

The use of shielded boxes and very short internal wiring ensured that the majority of coupling occurred in the cables. Any coupling that did occur through the enclosures was considered uniform across comparable tests and thus normalized out. A TEM cell setup was used over direct cable injection to better emulate a real-world radiated contamination problem and to enable the sensitivity of the shield-to-backshell connection to be investigated.

A key concern was to create an environment that provided repeatable measurements – not something that is necessarily easy to do when dealing with RF. In order to get repeatable data from our system, we kept the following parameters constant across the tests (unless specifically studying the effect of the variance).

- EM field levels and patterns
- Connectors
- Cable length

- Cable routing
- Chassis
- Shield connections
- Wire characteristics (manufacturer, gauge, shield material, coverage, impedance, etc.)

### III. CABLE TYPES

Cables often act as unintentional radiators in electrical systems. Both common-mode and differential-mode currents can cause the radiation, and each is dependent on different properties of the cable. Common-mode radiation has been shown to be proportional to cable length and signal frequency, whereas differential-mode radiation is proportional to the area enclosed by the differential mode current and the square of the signal frequency (1).

Reduction of common-mode radiation generally requires minimizing the common-mode current or common-mode signal frequency. As far as cabling, the only significant adjustments that can be made are to shield the cable, shorten the cable, or to isolate the offending cable with distance.

Similarly, reduction of differential-mode radiation can be accomplished by lowering the signal frequency (typically dominated by the edge rates), or minimizing the differential-mode current. Cabling considerations can also help, including shielding the cable, reducing the current loop area by using dedicated return wires, shortening the cable, or isolating the offending cable with distance.

In our investigation, we measured how much noise reduction was achieved using dedicated return wires as opposed to a single wire and chassis return. We also evaluated any additional improvement that was gained from twisting the two wires (see Fig. 3). For these measurements, unshielded cables were used since cable shielding effects were studied separately.

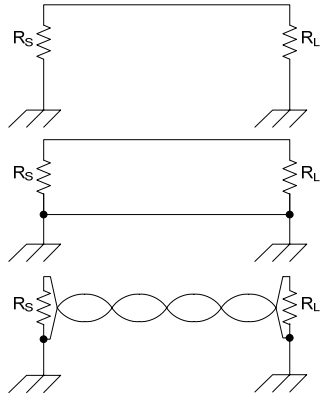

Fig. 3 Single wire, dedicated return, and twisted pair

#### A. Theory

From basic field theory, we would expect that adding a dedicated return wire would reduce the primary current loop area and thus reduce the total magnetic flux coupled into the receptor circuit. This is offset however by the ground loop formed by the chassis connections at each end.

It is also well understood that twisted pair wiring reduces magnetic field coupling because of the alternating polarity of each loop. Induced voltages from one loop cancel with adjacent loops. Twisted pair wiring can also reduce capacitive coupling if the wires are terminated in a balanced way at both ends – often not the case.

A simple model for twisted-pair wiring is shown in Fig. 4. The current and voltage sources model the capacitive and inductive coupling respectively. For the unbalanced case with one wire grounded, one half of the current sources will go to zero. The voltage sources will cancel completely for an even number of twists. For the case of an odd number of twists, a single remaining  $V_1, V_2$  will remain. This is to suggest that unbalanced twisted pair wiring will look like full-length untwisted wiring for capacitive coupling and a very short (single half twist length) untwisted wire for inductive coupling.

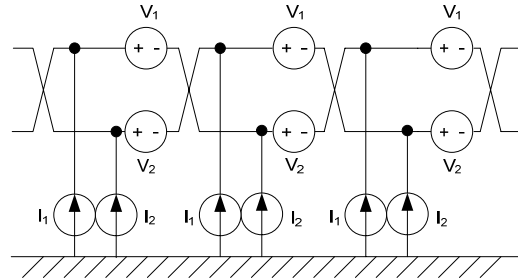

Fig. 4 Model for coupling on twisted pair wiring (1).

#### B. Experimental Data

Load noise was measured for the three configurations: single wire with chassis return, two wires with dedicated return, and twisted pair. A summary of the data is given in Table I. As expected, the inclusion of a dedicated return wire significantly and uniformly decreased the noise level by about 5.2dB (for frequencies with wavelength much less than the cable length). Additional improvement from twisting the wiring was shown to be minimal (~ 0.4dB).

TABLE I  
LOAD NOISE FOR VARIOUS WIRE CONFIGURATIONS

Frequency (MHz)	Single Wire (dB)	Two Wire (dB)	Twisted Pair (dB)
2 MHz	0	-5.2	-5.6
5 MHz	0	-5.3	-5.6
10 MHz	0	-5.3	-5.7
20 MHz	0	-4.2	-4.9
50 MHz	0	-15.8	-19.6
100 MHz	0	-9.4	-6.1
150 MHz	0	-13.1	+0.1
200 MHz	0	-3.2	-1.2

Results point to the need to include a dedicated return wire for every signal and power connection. Additionally in our case, the chassis offered a very uniform impedance (a single sheet of heavy gauge aluminum between boxes), but in many cases, the chassis structure is much more complicated – which could lead to significant frequency dependent characteristics if

used for signal return. One final drawback from using the chassis for signal or power return, is that it can introduce ground bounce in a system due to impedance sharing.

#### IV. SHIELD CONNECTIONS

One of the most pervasive questions that integrators wrestle with is how to effectively connect the cable shield. Many options exist, including tying the shield to:

- the chassis at the source and/or load using a conventional connector and pigtail connection,
- the chassis at the source and/or load using an EMI backshell with 360 degree coverage,
- a “quiet ground” in the system by routing it through a pin on the connector.

It is well understood that the effect of a shield is to reduce capacitive and inductive coupling. Numerous sources have shown that grounding the shield at one end will eliminate much of the capacitive coupling, but grounding it at both ends is required to reduce inductive coupling (1-6).

##### A. Capacitive Coupling

For electrically short lines, the induced noise due to capacitive coupling can be approximated by

$$V_{CAP} \cong \frac{j\omega R C_{NR}}{1 + j\omega R(C_{NR} + C_{RG})} V_N$$

where  $R$  represents the parallel combination of load and source resistances,  $C_{NR}$  represents the capacitance from the noise source to the receptor circuit, and  $C_{RG}$  represents the capacitance from the receptor wire to ground (1,2).

The effect of a shield around the receptor wire is to eliminate the capacitance from the receptor to ground ( $C_{RG}$ ), and to change the capacitance from the noise source to the receptor ( $C_{NR}$ ).

$$C_{NR} = \frac{C_{NS} C_{SR}}{C_{NS} + C_{SR}}$$

If the shield is grounded at one or both ends,  $C_{NS}$  is greatly reduced, because the electric field lines terminate on the shield. Note that for longer cables, the shield must be terminated periodically (e.g. every  $\lambda/10$ ) to achieve this effect. The reduction in capacitance causes a corresponding reduction in induced noise voltage.

##### B. Inductive Coupling

The noise voltage at the source and load ends due to inductive coupling can be approximated by

$$V_S^{IND} = \frac{R_S}{R_S + R_L} j\omega M_{NR} I_N \frac{R_{SH}}{R_{SH} + j\omega L_{SH}}$$

$$V_L^{IND} = -\frac{R_L}{R_L + R_S} j\omega M_{NR} I_N \frac{R_{SH}}{R_{SH} + j\omega L_{SH}}$$

where  $R_S$ ,  $R_L$ , and  $R_{SH}$  are the source, load, and shield resistances, and  $M_{NR}$  is the mutual inductance from the circuit with noise current  $I_N$  (1).

The effect of a shield is seen only in the last term of each equation. If the shield is not connected at both ends, the shield inductance will go to zero, driving the last term in the equations to unity – the shield thus offering no inductive noise reduction.

However, if the shield is grounded at both ends, the magnetic flux generated in the shield-to-ground plane circuit will generate a corresponding voltage in the shield that produces a current that counteracts the induced noise current.

##### B. Pigtails and 360-degree EMI Connectors

The term “pigtail” is used to denote the break in the shield required to tie it to ground – often at the backshell of the connector. The effect of the exposed signal wire and pigtail extension of the shield is to allow noise coupling to both the signal and shield. It is generally understood that the longer the pigtail, the worse the effect. But the question remains, is it the actual length/shape of the pigtail that drives the noise degradation or is it the length of exposed signal wire? Both effects were studied independently in our experiment in an attempt to get the answer.

Some connectors avoid the pigtail problem with backshells specifically designed to offer full coverage of the signal wires, (i.e. 360-degree shield connection). The performance of “EMI” connectors of this sort were compared to standard backshells that used pigtail connections. Fig. 5 shows the two connector types.



Fig. 5 EMI and pigtail connectors

##### C. Experimental Data

In our experiment, we measured the induced noise voltage at the load while varying the shield connection. Table II presents a summary of the test results. The headings OO, SO, OS, SS, and SS-EMI denote the particular shield connection, where O stands for open and S stands for short. So for example, OS indicates that the shield was left disconnected at the source side and connected at the load side. For all cases, the same shielded twisted pair wire was used. The SS-EMI case denotes a 360-degree connector versus the other standard connector with pigtail. The SS-PIN case denotes routing the shield through a connector pin to a quiet ground inside the box.

TABLE II  
LOAD NOISE WITH VARIOUS SHIELD CONNECTIONS

Frequency (MHz)	OO (dB)	SO (dB)	OS (dB)	SS (dB)	SS-PIN (dB)	SS-EMI (dB)
2 MHz	0	-7.0	-7.3	-25.1	-10.1	-47.2
5 MHz	0	-7.2	-7.7	-25.4	-10.8	-36.8
10 MHz	0	-5.9	-7.7	-22.9	-11.1	-26.3
20 MHz	0	+0.9	-5.1	-14.1	-10.4	-11.9
50 MHz	0	-2.3	-4.9	-2.4	+4.6	+9.4
100 MHz	0	+8.5	+10.5	+0.8	+5.2	+0.9
150 MHz	0	+12.9	-1.4	-17.4	+6.1	-16.1
200 MHz	0	-2.0	+7.3	+6.7	-0.3	+11.7

The data shows that for low frequencies, there was a uniform noise reduction of about 7 dB for shields tied to ground at one side (either source or load) and 25 dB for shields tied to both sides through pigtail connections. That attenuation drops to 10 dB if the shield is routed through a pin to a ground inside the box. The EMI backshell showed an impressive improvement over unshielded of as much as 47 dB.

However, as frequencies increased and the cable began to exceed the short-cable approximation of  $\lambda/20$ , all the results became dominated by standing wave patterns. Any potential benefit (or deficiency) caused by shielding became unpredictable. Fig. 6 shows the actual measured load noise with the various shield connections.

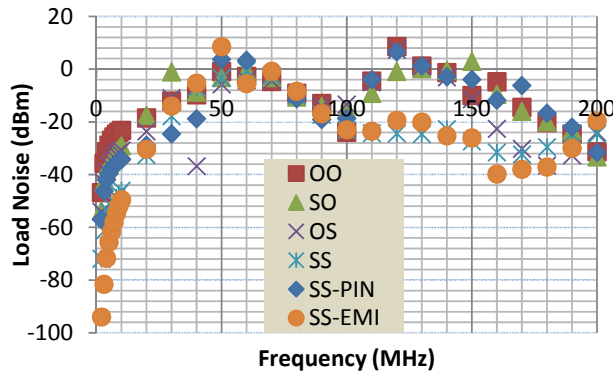

Fig. 6 Load noise with different shield connections

The next question we examined was noise coupling through the pigtail connection. First we investigated how sensitive the load noise was to pigtail loop area. What we found was that the load noise can vary up to 3dB by simply widening or narrowing the loop area of a 7.5 cm pigtail. Three things can be done to reduce this coupling. The pigtail can be kept short and tied flat against the cable thereby minimizing the pigtail loop area. If the electromagnetic field is known, the pigtail can also be oriented so that a minimum amount of magnetic flux passes through the loop.

We also measured the load noise for cables with various lengths of exposed wire but a common pigtail length. For these measurements, we tied the pigtail down to minimize loop area. Our goal was to determine how critical it is to

minimize the exposed wire (wire at the end of the cable that is uncovered when the shield is tied off to the backshell).

What we discovered was load noise could be reduced typically 1-3 dB by minimizing the length of exposed wire. Data normalized to the shortest pigtail length is given in Table III.

TABLE III  
LOAD NOISE FOR VARYING LENGTHS OF EXPOSED WIRE

Frequency (MHz)	Exposed Wire Length		
	2.5 cm (dB)	5.0 cm (dB)	7.5 cm (dB)
2 MHz	0	+3.4	+5.2
5 MHz	0	+1.1	+0.8
10 MHz	0	+1.2	+0.5
20 MHz	0	+0.7	+0.3
50 MHz	0	+2.4	+2.7
100 MHz	0	+0.4	-0.4
150 MHz	0	+2.1	+2.2
200 MHz	0	+1.8	+1.2

## V. CONCLUSIONS

Part 1 of our investigation into cable noise reduction techniques yielded four important conclusions. First and foremost is the reduction techniques only work reliably for electrically short cables (less than  $\lambda/20$ ). In our case that related to a maximum frequency of about 10 MHz. This reinforces the need to keep cable lengths short with respect to the signal wavelength.

The use of dedicated returns for every power and signal wire was shown reduce the magnetic coupling into cables by about 5dB. For additional noise immunity, the return can be twisted with the power or signal line. However twisting of cables does not reduce capacitive coupling for unbalanced applications, and in our measurements was shown to offer only minimal additional improvement in susceptibility.

Conventional shielding of cables can be quite effective at reducing both electric and magnetic field coupling (up to 25dB). Our results showed the greatest benefit is achieved by tying the shield to chassis at both ends. Pigtails outperformed routing the shield through a pin to an internal ground by about 15dB. If pigtails are to be used, they should be kept short and tied close to the cable to minimize the loop area. Finally, EMI backshells were shown to offer an additional 22dB of noise rejection.

## VI. REFERENCES

- [1] C.R. Paul, *Introduction to Electromagnetic Compatibility*, 2<sup>nd</sup> ed., Wiley Interscience, New Jersey, 2006.
- [2] H.W. Ott, *Noise Reduction Techniques in Electronic Systems*, 2<sup>nd</sup> ed., Wiley Interscience, New York, 1988.
- [3] D.A. Weston, *Electromagnetic Compatibility Principles and Applications*, 2<sup>nd</sup> ed., Marcel Dekker, New York, 2001.
- [4] M. Mardiguian, *Handbook Series on Electromagnetic Interference and Compatibility: Volume 2 – Grounding and Bonding*, Interference Control Technologies, Virginia, 1988.
- [5] R.B. Schulz, V.C. Plantz, and D.R. Brush, *Shielding Theory and Practice*, IEEE Transactions on Electromagnetic Compatibility, Vol. 30, No. 3, August 1988.
- [6] E.D. Knowles, L.W. Olson, *Cable Shielding Effectiveness*, IEEE Transactions on Electromagnetic Compatibility, Vol. EMC-16, No. 1, February 1974.