



# Development of a Temperature Sensor for Jet Engine and Space Missions Environments

*Richard L. Patterson  
Glenn Research Center, Cleveland, Ohio*

*Ahmad Hammoud  
ASRC Aerospace, Inc., Glenn Research Center, Cleveland, Ohio*

*Dennis E. Culley  
Glenn Research Center, Cleveland, Ohio*

*Malik Elbuluk  
University of Akron, Akron, Ohio*

## NASA STI Program . . . in Profile

Since its founding, NASA has been dedicated to the advancement of aeronautics and space science. The NASA Scientific and Technical Information (STI) program plays a key part in helping NASA maintain this important role.

The NASA STI Program operates under the auspices of the Agency Chief Information Officer. It collects, organizes, provides for archiving, and disseminates NASA's STI. The NASA STI program provides access to the NASA Aeronautics and Space Database and its public interface, the NASA Technical Reports Server, thus providing one of the largest collections of aeronautical and space science STI in the world. Results are published in both non-NASA channels and by NASA in the NASA STI Report Series, which includes the following report types:

- **TECHNICAL PUBLICATION.** Reports of completed research or a major significant phase of research that present the results of NASA programs and include extensive data or theoretical analysis. Includes compilations of significant scientific and technical data and information deemed to be of continuing reference value. NASA counterpart of peer-reviewed formal professional papers but has less stringent limitations on manuscript length and extent of graphic presentations.
- **TECHNICAL MEMORANDUM.** Scientific and technical findings that are preliminary or of specialized interest, e.g., quick release reports, working papers, and bibliographies that contain minimal annotation. Does not contain extensive analysis.
- **CONTRACTOR REPORT.** Scientific and technical findings by NASA-sponsored contractors and grantees.
- **CONFERENCE PUBLICATION.** Collected

papers from scientific and technical conferences, symposia, seminars, or other meetings sponsored or cosponsored by NASA.

- **SPECIAL PUBLICATION.** Scientific, technical, or historical information from NASA programs, projects, and missions, often concerned with subjects having substantial public interest.
- **TECHNICAL TRANSLATION.** English-language translations of foreign scientific and technical material pertinent to NASA's mission.

Specialized services also include creating custom thesauri, building customized databases, organizing and publishing research results.

For more information about the NASA STI program, see the following:

- Access the NASA STI program home page at <http://www.sti.nasa.gov>
- E-mail your question via the Internet to [help@sti.nasa.gov](mailto:help@sti.nasa.gov)
- Fax your question to the NASA STI Help Desk at 301-621-0134
- Telephone the NASA STI Help Desk at 301-621-0390
- Write to:  
NASA Center for AeroSpace Information (CASI)  
7115 Standard Drive  
Hanover, MD 21076-1320



# Development of a Temperature Sensor for Jet Engine and Space Missions Environments

*Richard L. Patterson*  
*Glenn Research Center, Cleveland, Ohio*

*Ahmad Hammoud*  
*ASRC Aerospace, Inc., Glenn Research Center, Cleveland, Ohio*

*Dennis E. Culley*  
*Glenn Research Center, Cleveland, Ohio*

*Malik Elbuluk*  
*University of Akron, Akron, Ohio*

National Aeronautics and  
Space Administration

Glenn Research Center  
Cleveland, Ohio 44135

## Acknowledgments

This work was performed under the NASA Glenn Research Center, GESS-2 Contract no. NNC06BA07B. Support was provided by the NASA GRC Fundamental Aeronautics/Subsonic Fixed Wing Program and by the NASA Electronic Parts and Packaging (NEPP) Program.

Trade names and trademarks are used in this report for identification only. Their usage does not constitute an official endorsement, either expressed or implied, by the National Aeronautics and Space Administration.

*Level of Review:* This material has been technically reviewed by technical management.

Available from

NASA Center for Aerospace Information  
7115 Standard Drive  
Hanover, MD 21076-1320

National Technical Information Service  
5285 Port Royal Road  
Springfield, VA 22161

Available electronically at <http://gltrs.grc.nasa.gov>

# **Development of a Temperature Sensor for Jet Engine and Space Missions Environments**

Richard L. Patterson  
National Aeronautics and Space Administration  
Glenn Research Center  
Cleveland, Ohio 44135

Ahmad Hammoud  
ASRC Aerospace, Inc.  
Glenn Research Center  
Cleveland, Ohio 44135

Dennis E. Culley  
National Aeronautics and Space Administration  
Glenn Research Center  
Cleveland, Ohio 44135

Malik Elbuluk  
University of Akron  
Akron, Ohio 44325

## **Abstract**

Electronic systems in aerospace and in space exploration missions are expected to encounter extreme temperatures and wide thermal swings. To address the needs for extreme temperature electronics, research efforts exist at the NASA Glenn Research Center (GRC) to develop and evaluate electronics for extreme temperature operations, and to establish their reliability under extreme temperature operation and thermal cycling; conditions that are typical of both the aerospace and space environments. These efforts are supported by the NASA Fundamental Aeronautics/Subsonic Fixed Wing Program and by the NASA Electronic Parts and Packaging (NEPP) Program. This work reports on the results obtained on the development of a temperature sensor geared for use in harsh environments.

## **Extreme Temperature Electronics**

Advanced electronic systems emphasize compactness, lightweight, increased energy density, reliability, and highly efficient operation. In addition, operation of these systems in hostile environments, where extreme temperatures are encountered, is anticipated in many applications. For example, jet engine distributed control architecture requires sensors and related circuitry to be co-located with actuators and transducers in the engine's hot zone where temperature can easily exceed 150 °C. Deep space probes destined to Venus and Mercury would also encounter high temperatures, and so would the electronics designed for use in the Navy's all-electric boat, and power-by-wire aircraft. At the other end of the spectrum, extreme cold temperatures are also anticipated in space as well as aerospace applications. An interplanetary probe launched to explore the rings of Saturn would experience an average temperature of about -183 °C near Saturn, and electronics deployed near planet Pluto, for instance, would be exposed to temperatures as low as -229 °C. Also, systems designed for use behind the sun shield on the NASA James Webb Space Telescope will require the use of cryogenic detectors to capture weak distant signals. In addition to extreme temperature exposure, electronics in applications such as lunar surface exploration and earth-orbiting satellites are expected to be subjected to repeated thermal cycling covering a wide temperature range. The need for electronics capable of operation in extreme temperatures is not limited

only to space ventures or military applications, but it also encompasses many terrestrial industries. These include magnetic levitation transportation systems, power generation facilities, down-hole instrumentation for gas and oil exploration, automotive, medical imaging, particle acceleration and confinement, and Arctic and Antarctic exploratory missions. Besides meeting the environment operational conditions, electronics that are able to tolerate and operate efficiently in extreme temperatures will negate the need for the traditional thermal control elements and their associated structures for proper ambient operation. This, in turn, would lead to many other benefits including decreased overall system mass and size, simplified design, and reduced power requirements. In addition, reduced development time and launch costs, as well as extended mission operations for longer exploration time can be achieved. Therefore, it is highly desirable and vital to have electronic systems capable of withstanding and operating reliably in hostile temperature environments.

## Temperature Sensor

Efforts were carried out to develop and evaluate a temperature sensor for the NASA Jet Engine Distributed Control Program. The distributed control architecture requires that sensors and associated electronics be co-located with monitoring and control transducers for engines and actuators in very hot environments. In addition to meeting the operational requirements, placement of the electronics in the harsh engine compartment allows simpler signal multiplexing, improves system performance, and avoids or minimizes signal degradation. The combination of GRC high temperature development work for Jet Engine Distributed Control and GRC low temperature reliability work for the NASA Electronic Parts and Packaging (NEPP) Program has yielded a new technical approach for very wide temperature electronics design and production wherein circuits can operate between  $-195$  and  $200$  °C. In addition, there are technical reasons to believe that operating temperatures may be extended below  $-195$  and above  $200$  °C.

The sensor was designed to sense temperature and to produce a digital output consisting of a stream of rectangular pulses whose frequency is a function of the sensed temperature. The output frequency will be fed into a digital data acquisition system that will give a direct readout of the temperature through the use of a look-up table, a built-in algorithm, or a mathematical model. In order to develop this sensor circuitry, a literature survey was performed to determine the simplest and most efficient circuit configuration that could be utilized as a temperature-to-frequency conversion sensor in extreme temperature applications. A search for commercial-off-the-shelf (COTS) electronic parts that could be utilized at extreme temperatures was also performed. A relaxation oscillator topology was selected to build the temperature-to-frequency circuit using an RTD (Resistance Temperature Detector) as the temperature-sensing element. A schematic of the circuit is shown in figure 1, and the selected COTS parts are listed in table I.

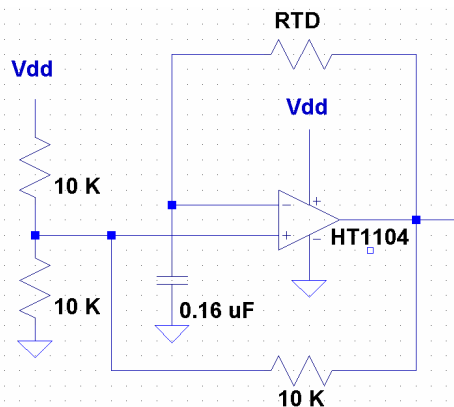

Figure 1.—Schematic of the temperature-to-frequency relaxation oscillator circuit.

TABLE I.—PARTS LIST USED IN CONSTRUCTION OF THE TEMPERATURE SENSOR CIRCUIT

Part	Part #	Company	Temp (°C)	Features
Operational amplifier	HT1104	Honeywell	-55 to 225	SOI technology, hermetic ceramic DIP package
RTD	PPG102A1	U.S. Sensor	-50 to 500	Thin film platinum, ceramic package
Capacitor	SM041A164KAN240	AVX	-55 to 125	MLC NPO ceramic
Resistor	MM177-1.0K-1%	Caddock	275	High temperature precision film resistor

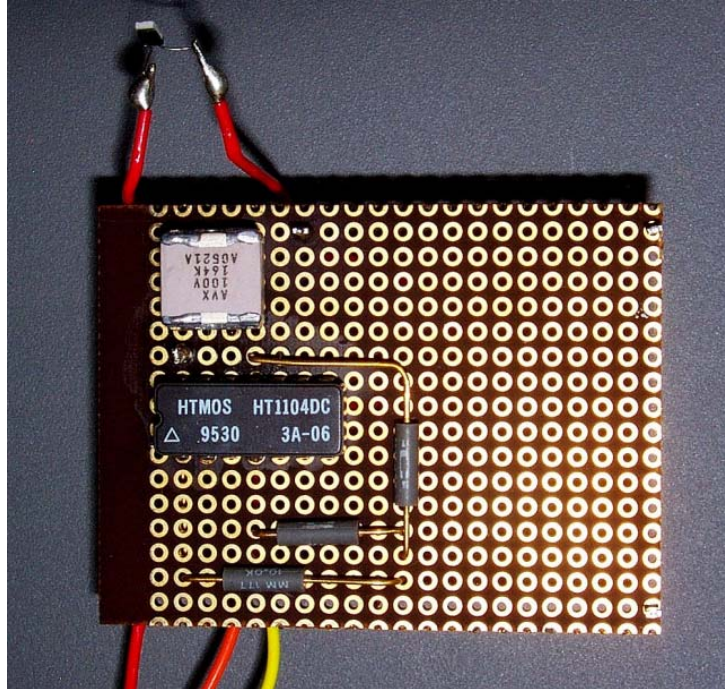

Figure 2.—Temperature-to-frequency relaxation oscillator circuit board.

The temperature-to-frequency relaxation oscillator circuit was assembled using a high temperature polyimide board, Teflon-insulated wire interconnects, and high temperature lead-free solder. The circuit employed a Honeywell high temperature Silicon-On-Insulator (SOI) operational amplifier HT1104. This chip is fabricated with Honeywell's dielectrically isolated high-temperature linear HTMOS process, is specified for -55 to 225 °C operation, and is able to perform up to 300 °C (ref. 1). It is a 14-lead, monolithic amplifier in a hermetic ceramic package, and can handle 15 mA output current with a single or split supply. A high temperature precision, thin film platinum RTD (Resistance Temperature Detector) (ref. 2) was selected as the temperature-sensing element, while the other passive elements consisted of a multi-layer ceramic (MLC) capacitor (ref. 3) and three high temperature, precision film resistors (ref. 4). The circuit was evaluated at selected test temperatures between -195 and 200 °C. A temperature rate of change of 10 °C/min and a dwell time of 20 min at test temperature were used in these investigations. Circuit evaluation was performed by measuring output frequency as a function of temperature, variation in the output signal duty cycle and rise time, and the circuit supply current. A photograph of the actual circuit board is shown in figure 2.

## Results

A typical output response of the temperature-to-frequency conversion circuit, which comprised of a digital pulse train, is shown in figure 3 at 25 °C. Those obtained at the high temperature of 200 °C and at the cryogenic temperature of -195 °C are shown in figures 4 and 5, respectively.

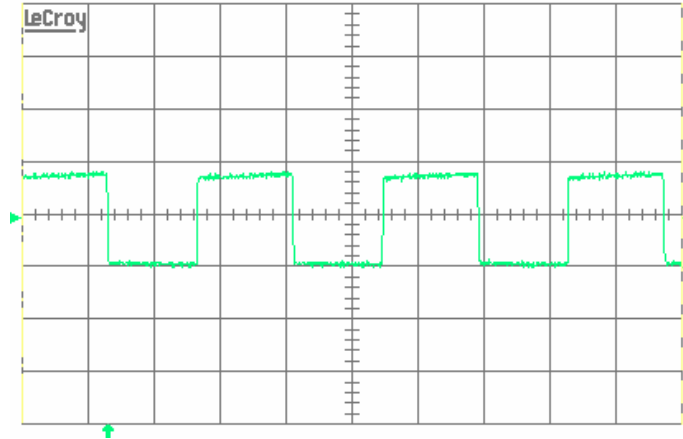

Figure 3.—Output waveform of the temperature-to-frequency circuit at 25 °C.

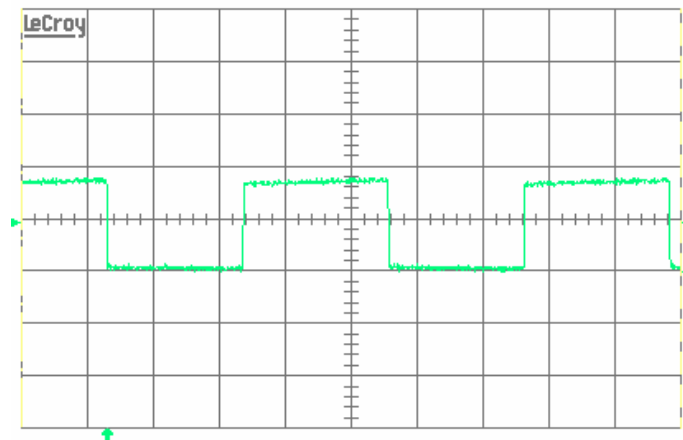

Figure 4.—Output waveform of the temperature-to-frequency circuit at 200 °C.

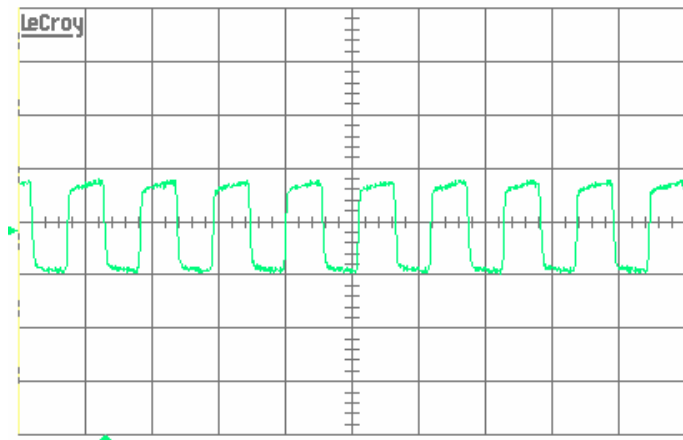

Figure 5.—Output waveform of the temperature-to-frequency circuit at -195 °C.



The circuit performed very well throughout the test temperature range between 200 and  $-195\text{ }^{\circ}\text{C}$ . As expected, the frequency of the output signal fluctuated with variation in the sensed temperature; with a frequency of about 9.2 kHz at a test temperature of  $-195\text{ }^{\circ}\text{C}$  and a frequency of 2.3 kHz at 200  $^{\circ}\text{C}$ . This frequency response with temperature is depicted in figure 6(a). The period for the pulse train is shown in figure 6(b). A linear curve-fit has been placed over the data points. For the linear curve-fit, the R squared was 0.9994. No major change was experienced by the duty cycle of the output signal as shown in figure 7.

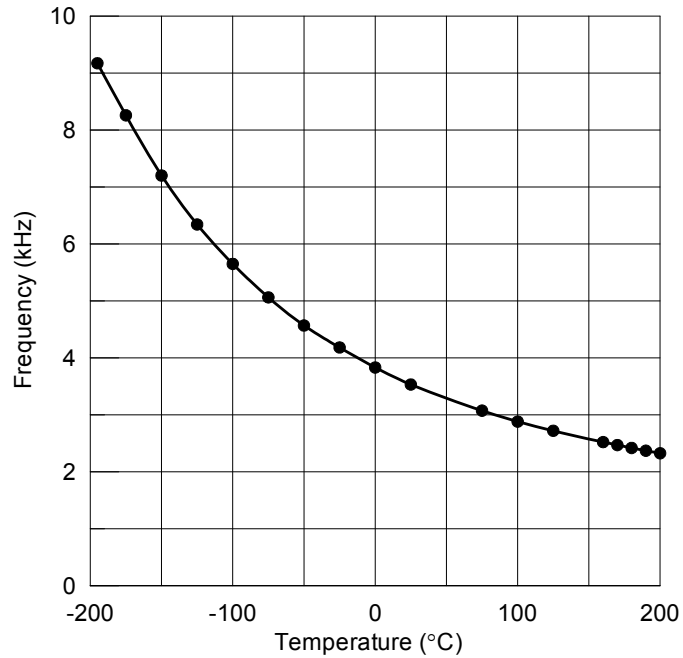

Figure 6(a).—Output frequency versus temperature.

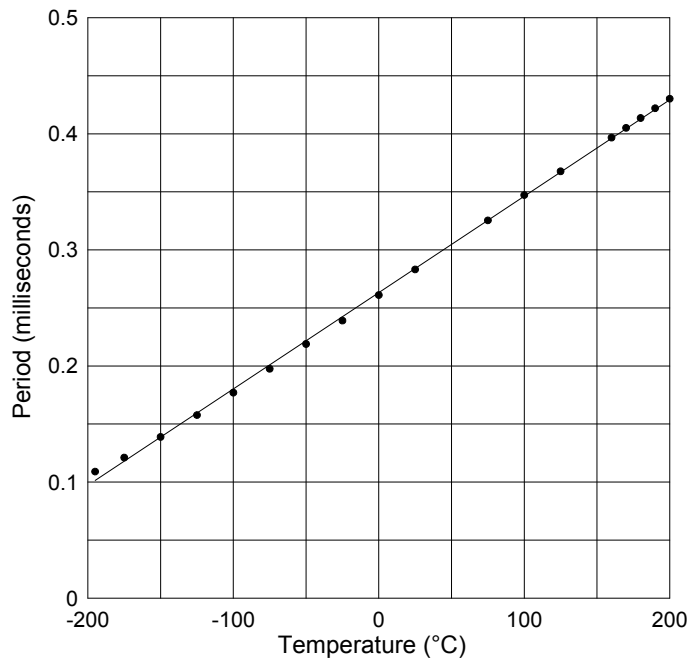

Figure 6(b).—Pulse train period versus temperature.

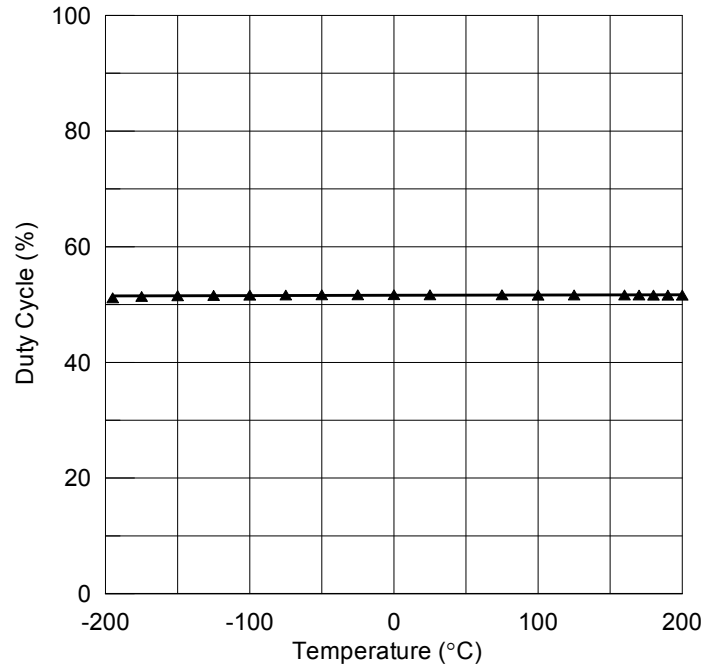

Figure 7.—Duty cycle of output signal as a function of temperature.

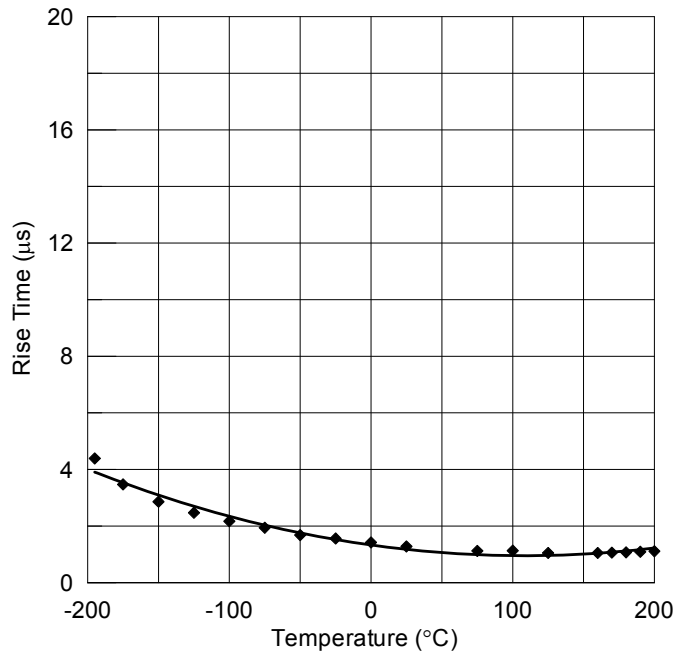

Figure 8.—Rise time of output signal versus temperature.

While the rise time of the output signal held steady value between 25 and 200 °C, it did, however, undergo a very slight increase as the temperature was decreased below room temperature, as shown in figure 8. The rise time increased from a value of 1.3 μs at 25 °C to a value of 4.2 μs at -195 °C. The supply current of the circuit remained between 4 to 8 mA throughout these tests. Figure 9 shows supply current as a function of temperature.

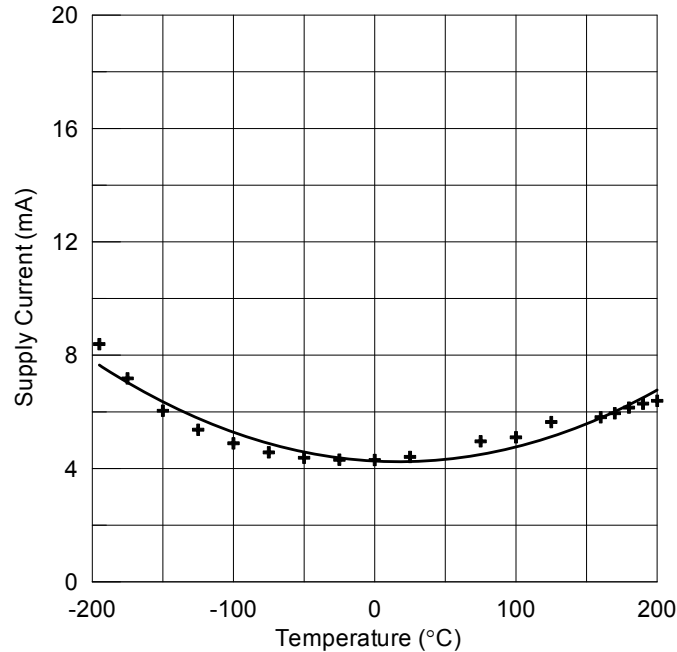

Figure 9.—Circuit supply current as a function of temperature.

## Conclusions

A temperature-to-frequency relaxation oscillator circuit was constructed using COTS parts for application under extreme temperatures. The circuit employed a high temperature SOI operational amplifier, a thin-film platinum RTD, an NPO multi-layer ceramic capacitor, and precision film resistors. Although the circuit was designed mainly for a hot jet engine environment, it was evaluated also for potential use under cryogenic conditions. Performance of the oscillator circuit was investigated in terms of its frequency response, pulse train period, variation in output signal duty cycle and rise time, and supply current under a wide temperature range between  $-195$  and  $200$  °C. The prototype circuit performed well throughout this temperature range in producing a pulse train whose period was proportional to the sensed temperature, and no major changes were observed in its characteristics, i.e. duty cycle and rise time of the output signal, as a result of change in test temperature. In addition, all of the individual parts exhibited no physical or packaging damage due to the extreme temperature exposure. It can be concluded, therefore, that all the COTS parts used in designing the circuit exhibited good performance under wide temperature swing, and these preliminary results suggest that the circuit has good potential for use in both hot and cold temperature environments. Issues such as long-term exposure to extreme temperatures, thermal cycling, and mechanical vibrations, that are typically encountered in jet engine environs, need to be addressed to establish reliability of the circuit and to better determine its suitability for use in hostile space and aerospace applications.

## References

1. Honeywell Company, “High Temperature Quad Operational Amplifier HT1104,” Datasheet 900134 Rev. B, 9-03.
2. U.S. Sensor, “Thin Film Platinum RTD’s,” Data Sheet.
3. AVX Corp., “SMPS Stacked MLC Capacitors,” Data Sheet.
4. Caddock Electronics, Inc. “Type MM and ML Precision Film Resistors,” Data Sheet 28-IL124.1004.

**REPORT DOCUMENTATION PAGE**

*Form Approved*  
OMB No. 0704-0188

The public reporting burden for this collection of information is estimated to average 1 hour per response, including the time for reviewing instructions, searching existing data sources, gathering and maintaining the data needed, and completing and reviewing the collection of information. Send comments regarding this burden estimate or any other aspect of this collection of information, including suggestions for reducing this burden, to Department of Defense, Washington Headquarters Services, Directorate for Information Operations and Reports (0704-0188), 1215 Jefferson Davis Highway, Suite 1204, Arlington, VA 22202-4302. Respondents should be aware that notwithstanding any other provision of law, no person shall be subject to any penalty for failing to comply with a collection of information if it does not display a currently valid OMB control number.

PLEASE DO NOT RETURN YOUR FORM TO THE ABOVE ADDRESS.

<b>1. REPORT DATE (DD-MM-YYYY)</b> 01-05-2008		<b>2. REPORT TYPE</b> Technical Memorandum		<b>3. DATES COVERED (From - To)</b>	
<b>4. TITLE AND SUBTITLE</b> Development of a Temperature Sensor for Jet Engine and Space Missions Environments				<b>5a. CONTRACT NUMBER</b>	
				<b>5b. GRANT NUMBER</b>	
				<b>5c. PROGRAM ELEMENT NUMBER</b>	
<b>6. AUTHOR(S)</b> Patterson, Richard, L.; Hammoud, Ahmad; Culley, Dennis, E.; Elbuluk, Malik				<b>5d. PROJECT NUMBER</b>	
				<b>5e. TASK NUMBER</b>	
				<b>5f. WORK UNIT NUMBER</b> WBS 939904.01.03.02.01	
<b>7. PERFORMING ORGANIZATION NAME(S) AND ADDRESS(ES)</b> National Aeronautics and Space Administration John H. Glenn Research Center at Lewis Field Cleveland, Ohio 44135-3191				<b>8. PERFORMING ORGANIZATION REPORT NUMBER</b> E-16402	
<b>9. SPONSORING/MONITORING AGENCY NAME(S) AND ADDRESS(ES)</b> National Aeronautics and Space Administration Washington, DC 20546-0001				<b>10. SPONSORING/MONITORS ACRONYM(S)</b> NASA	
				<b>11. SPONSORING/MONITORING REPORT NUMBER</b> NASA/TM-2008-215160	
<b>12. DISTRIBUTION/AVAILABILITY STATEMENT</b> Unclassified-Unlimited Subject Category: 33 Available electronically at <a href="http://gltrs.grc.nasa.gov">http://gltrs.grc.nasa.gov</a> This publication is available from the NASA Center for AeroSpace Information, 301-621-0390					
<b>13. SUPPLEMENTARY NOTES</b>					
<b>14. ABSTRACT</b> Electronic systems in aerospace and in space exploration missions are expected to encounter extreme temperatures and wide thermal swings. To address the needs for extreme temperature electronics, research efforts exist at the NASA Glenn Research Center (GRC) to develop and evaluate electronics for extreme temperature operations, and to establish their reliability under extreme temperature operation and thermal cycling; conditions that are typical of both the aerospace and space environments. These efforts are supported by the NASA Fundamental Aeronautics/Subsonic Fixed Wing Program and by the NASA Electronic Parts and Packaging (NEPP) Program. This work reports on the results obtained on the development of a temperature sensor geared for use in harsh environments.					
<b>15. SUBJECT TERMS</b> Electronics; Amplifiers; Silicon-on-insulator; Extreme temperature; HT1104					
<b>16. SECURITY CLASSIFICATION OF:</b>			<b>17. LIMITATION OF ABSTRACT</b>	<b>18. NUMBER OF PAGES</b> 13	<b>19a. NAME OF RESPONSIBLE PERSON</b> STI Help Desk (email:help@sti.nasa.gov)
<b>a. REPORT</b> U	<b>b. ABSTRACT</b> U	<b>c. THIS PAGE</b> U			<b>19b. TELEPHONE NUMBER (include area code)</b> 301-621-0390



