

Frequency-tunable pre-stabilized lasers for LISA via sideband-locking

J C Livas¹, J I Thorpe¹, K Numata^{1,2}, S Mitryk³, G Mueller³, and V Wand³

¹NASA Goddard Space Flight Center, 8800 Greenbelt Road, Greenbelt, MD 20771 USA

²Department of Astronomy, University of Maryland, College Park, MD 20742 USA

³Department of Physics, University of Florida, Gainesville, FL 32611 USA

E-mail: Jeffrey.Livas@nasa.gov

Abstract.

Laser frequency noise mitigation is one of the most challenging aspects of the LISA interferometric measurement system. The unstabilized frequency fluctuations must be suppressed by roughly twelve orders of magnitude in order to achieve stability sufficient for gravitational wave detection. This enormous suppression will be achieved through a combination of stabilization and common-mode rejection. The stabilization component will itself be achieved in two stages: pre-stabilization to a local optical cavity followed by arm-locking to some combination of the inter-spacecraft distances. In order for these two stabilization stages to work simultaneously, the lock-point of the pre-stabilization loop must be frequency tunable. The current baseline stabilization technique, locking to an optical cavity, does not provide tunability between cavity resonances, which are typically spaced by 100s of MHz. Here we present a modification to the traditional Pound-Drever-Hall cavity locking technique that allows the laser to be locked to a cavity resonance with an adjustable frequency offset. This technique requires no modifications to the optical cavity itself, thus preserving the stability of the frequency reference. We present measurements of the system performance and demonstrate that we can meet implement the first two stages of stabilization.

1. Introduction

The LISA instrument detects gravitational waves by measuring the differential separation between widely separated spacecraft using a rotating triangular system of three spacecraft [1].

As in any interferometer, the differential length measurement will be sensitive to laser frequency fluctuations unless the path lengths of the interfering arms are identical. The LISA spacecraft are in independent orbits, so it is not possible to make the separation between each spacecraft identical even in principle. Therefore, it is necessary to actively reduce the product of the relative frequency noise and the worst case path length difference to a level comparable to the required strain sensitivity $(\delta\nu/\nu)\times\Delta x\approx 10^{-21}$. The current baseline design proposes to accomplish the frequency noise reduction using a 3-step process: pre-stabilization, arm-locking, and time-delay interferometry (TDI) [2]. The allocation of required performance among these three methods is not unique. Figure 1 shows one example of how the different methods might be used to get the required level of stability.

The present plan is to use these different stabilization methods in series with a set of nested control loops. Pre-stabilization of the free-running laser to a frequency reference such as a cavity means that the center frequency of the laser is then locked to one of a range of discrete values characteristic of the reference and separated by the free-spectral range (FSR) of the cavity, typically several x 100 MHz. When it becomes

necessary to transfer the pre-stabilized laser to the next level of reference, as for example with arm-locking, it is necessary to tune the center frequency of the laser to match the new reference. The tunability required for this application is relatively narrow since even a 1 GHz change in the carrier frequency is a fractional change of only 3 parts per million. Put another way, a one nm wavelength shift corresponds to 265 GHz at the center wavelength of the LISA laser (1064 nm).

Figure 1. Example of one way to achieve the required frequency stability using pre-stabilization, arm-locking, and TDI.

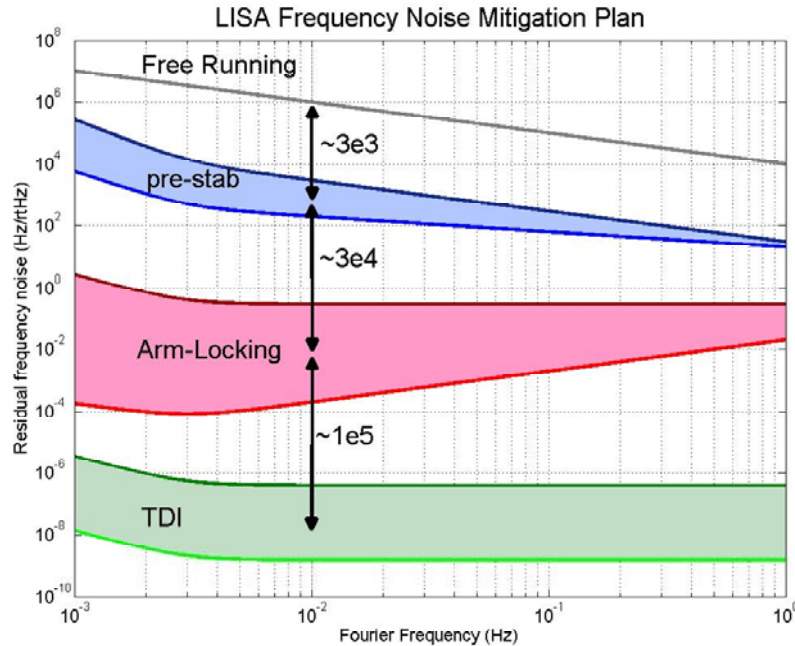

2. Offset locking techniques

2.1 Tunability options

There are a number of ways to make a laser tunable over a narrow band. The ideal method would allow a large frequency offset while preserving the frequency stability of the non-tunable source. In general a method of adjustment for the frequency is also a conduit for noise to enter the system, so it is important to understand the potential noise sources to minimize the introduction of noise. In addition, for application to LISA it would be useful to be able to tune the laser at a high rate so that the frequency tuning capability could be used as a high bandwidth actuator in a control loop. Table 1 summarizes some of the possible methods.

Table 1. Laser frequency tuning methods.

Tuning method	Range	Speed	Advantages	Disadvantages
Acousto-Optic Modulator	10's of MHz	~MHz	Simple – one device	Low drive power efficiency Beam steering
PZT on cavity mirror	100's of MHz	~100 kHz	Simple implementation	Requires modified reference
Offset Phase-locking	10's of MHz	~ 10 kHz	Simple implementation	Requires an additional laser
Offset sideband locking	10's of GHz	~30 kHz	No modification to the reference cavity	Complex modulation spectrum

Perhaps the simplest option is to use an acousto-optic modulator (AOM)[2]. Due to the nature of the physical mechanism for frequency shifting these devices tend to be inefficient in terms of their operating power requirements, and the frequency tuning process also steers the beam. Variations in pointing can cause noise when sampling the reference. For applications on the ground, there are techniques to minimize beam steering – for example by optically double-passing the AOM crystal. For spaceflight, the additional complexity of the double-pass optics and the power inefficiency combine to make the AOM probably not the best choice.

A reference cavity can be made tunable by placing a device to change the spacing of the cavity, such as a PZT, between the cavity spacer and the end mirror. The main disadvantage of this approach is that it requires modification of the reference cavity, but good results have been obtained [4].

Another tuning method is to frequency stabilize a laser to a cavity and then phase lock another laser to the stabilized laser. The phase lock allows the second laser to run at a different frequency but retain the frequency stability of the first laser. This is a well-known technique, but requires an additional laser [5].

The tuning methods described in this work are based on the standard Pound-Drever-Hall (PDH) cavity stabilization technique [6,7]. One of the main advantages of these techniques is that they require minimal change the hardware needed for the standard technique. In particular no modification of the frequency reference is required. Another advantage is that there are implementation options that enable a very large tuning range. Figure 2 shows three implementations that were considered.

Figure 2a, b, c. Offset locking techniques for laser frequency tunability.

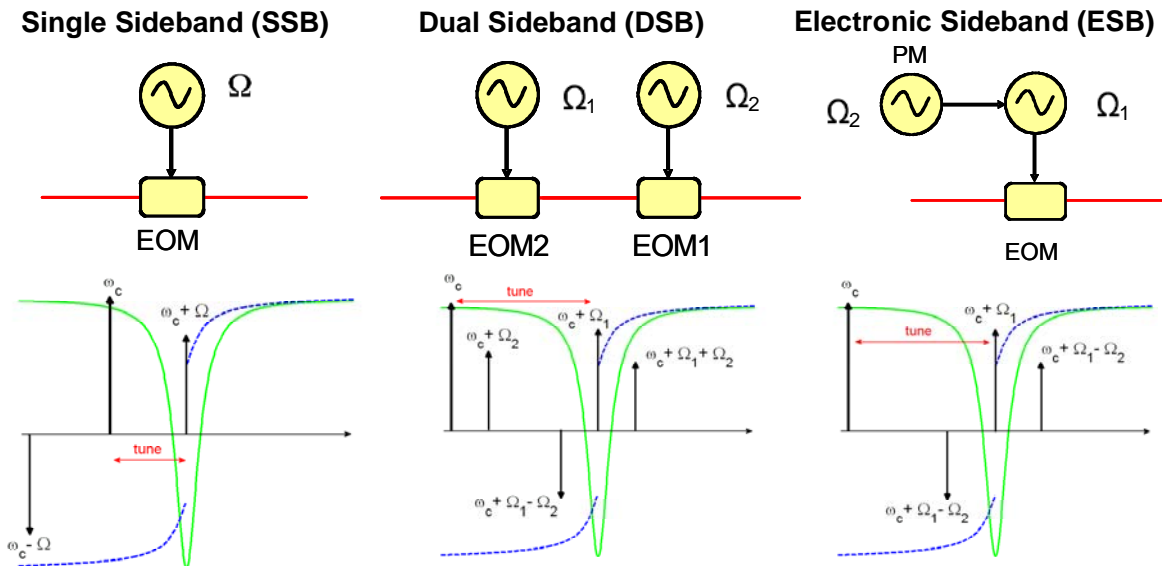

2.2 Sideband (SSB)

Single sideband locking, shown in Figure 2a, is identical to standard PDH locking except that the error signal used for locking is one of the error signals of a sideband instead of the error signal from the carrier. Tunability is accomplished simply by changing the frequency of the phase modulation of the carrier. The component count for the locking system is the same as that for standard PDH except that a broadband phase modulator is required instead of a fixed frequency resonant modulator

Although this approach is simple, there are a number of drawbacks. The asymmetry of the sidebands in the locked configuration makes the system sensitive to amplitude noise in the laser. Tuning is

accomplished by changing the frequency of the modulation sidebands, so the demodulation electronics must be able to follow these changes in frequency. In practice this limits the tunable range to a few 10^3 's of MHz.

2.3 Dual sideband (DSB)

Dual sideband locking, shown in Figure 2b, works by imposing two sets of sidebands on the carrier. One set of sidebands is at a fixed frequency just as in standard PDH locking. The other, tunable, sideband acts functionally as though it were the laser carrier. The optical spectrum contains sidebands that look identical to the PDH spectrum about the carrier. The easiest way to produce this kind of spectrum is to imagine using two separate electro-optic modulators – a broadband one for the tuning, and a resonant one for the PDH sidebands.

The demodulation electronics are identical to that of the PDH method, and the range, over which the laser is tunable, is limited only by the bandwidth of the modulator used to add the tunable sideband.

One drawback is that the optical spectrum is complex. With the proper choice of modulator it is possible to drive the optical carrier into suppression, but there are still many potential system lock points, and in particular at low modulation levels the error signal from the carrier is typically much larger than the error signal at the desired offset sideband, making it difficult to lock.

2.4 Electronic sideband (ESB)

A simple variant of the dual sideband locking technique that addresses the complex spectrum issue is the electronic sideband method. The idea here is to phase modulate just the tunable offset with the fixed frequency PDH sidebands. The optical spectrum then becomes simpler because the carrier no longer has the phase modulation sidebands needed to generate an error signal (compare Figure 2b and 2c). The system no longer sees a strong error signal at the carrier and it becomes easier to lock.

The demodulation electronics is identical to that for the standard PDH method. The main drawback of this method is that it requires a tunable oscillator that can be phase modulated.

2.5 Relative shot noise limited responses

A natural question to ask about these alternative frequency stabilization schemes is how the performance compares against the standard PDH method. One way to assess this is to look at the estimated shot-noise-limited performance by dividing the shot noise on the demodulation detector by the optical discriminator gain [8]. Table 2 shows a summary of how this works for the 3 methods considered, using the standard PDH as the reference. The first column represents the magnitude of the average reflected power on the demodulation detector as a function of the modulation depth. The middle column shows the value of the optical discriminator for each method, written in terms of the modulation depth and normalized to the PDH standard. The modulation depth that minimizes the quotient of shot noise divided by discriminator gain is shown in the fourth column. The last column shows the performance at the optimum modulation depth relative to the standard PDH method. This calculation indicates that, if optimized, the shot noise limited performance of either the DSB or ESB methods is 5.5 times worse than the standard PDH method. In practice, systems are normally not shot noise limited and so this comparison does not necessarily hold. In particular for LISA, we will show later that the expected noise from thermal fluctuations of the reference cavity dominates the noise performance over the LISA measurement passband. Therefore there will be no penalty (at least in principle) from using a tunable cavity locking technique for LISA.

Table 2. Shot noise limited performance for different offset locking methods

Method	P_{ref}/P_0	$ D \times (v_{FWHM}/P_0)$	β_{opt}	$S_{shot}/S_{shot,PDH}$
PDH	$1 - J_0^2(\beta)$	$8J_0(\beta)J_1(\beta)$	0	1
SSB	$1 - J_1^2(\beta)$	$0.5D_{PDH}(\beta)(J_0(\beta) - J_2(\beta))J_0(\beta)$	0.97	4.4
DSB/ESB	$1 - J_0^2(\beta_2)J_1^2(\beta_1)$	$D_{PDH}(\beta_2)J_1^2(\beta_1)$	$\beta_1 \rightarrow 1.84$ $\beta_2 \rightarrow 1.01$	5.5

3. Results

We modified a standard PDH optical system to allow us to study these tunable frequency techniques in the laboratory. Figure 3 shows the optical layout. The main difference between this setup and a standard PDH system is the addition of a broadband electrooptic modulator (EOM) in series with the normal resonant EOM. This configuration was chosen for experimental convenience and is not strictly necessary; we wanted to be able to recover the baseline system simply by shutting off the broadband EOM. A separate laser system locked to a fixed reference cavity with the standard PDH method is used to evaluate the performance of the frequency-tunable system and is not shown explicitly in Figure 3 except as the source of the reference beam entering the system from the left.

Table 3 summarizes how the modulators are configured for the different methods. For SSB there is no change to the standard PDH setup. We simply operate with the frequency discriminant from one of the sidebands, and optimize the total loop gain by compensating for the smaller optical gain by boosting the electronic gain. For DSB, the broadband EOM is modulated with a tunable CW frequency, and the resonant EOM is driven exactly as for standard PDH. Once again, we optimize the overall loop gain by compensating lower optical gain with electronics gain. Note that in principle the tunable CW frequency and the fixed PDH sideband frequency could be mixed electronically and applied to a single broadband modulator. For ESB, a signal consisting of a phase modulated tunable carrier is applied to the broadband modulator. The component count is the same as for standard PDH, although a broadband modulator is required and a somewhat more complicated RF modulation source.

Figure 3. Laboratory setup for studying offset sideband locking. A standard PDH system with a fixed reference cavity (not shown) is used as a reference for measuring the frequency noise performance of this test setup.

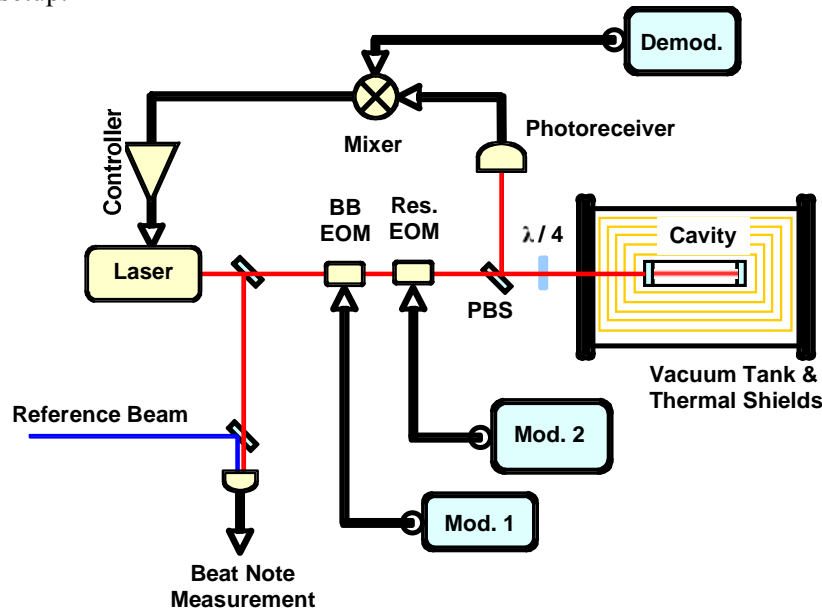
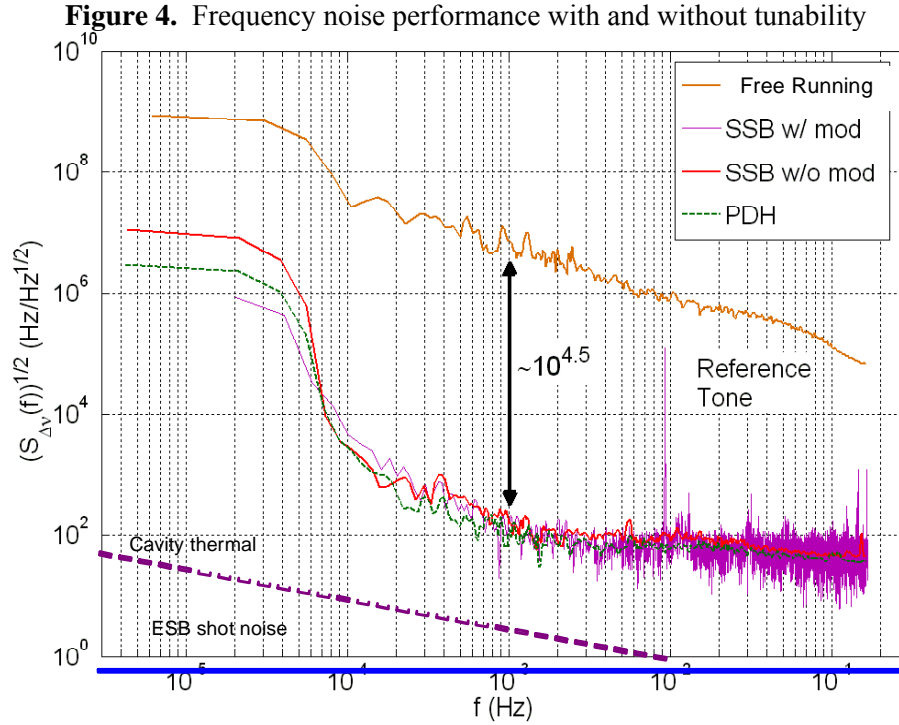

Table 3. Configuration of the optical layout shown in Figure 3 for different tuning methods.

Method	Mod. 1	Mod. 2	Demod
PDH	Ω (fixed)	Not used	Ω (fixed)
SSB	Ω (tunable)	Not used	Ω (tunable)
DSB	Ω_1 (tunable)	Ω_2 (fixed)	Ω_2 (fixed)
ESB	Ω_1 (tunable) with Ω_2 (fixed)	Not used	Ω_2 (fixed)

Substitution of a fiber-coupled waveguide electrooptic modulator for the bulk modulator used in these experiments is expected to greatly reduce the electrical drive requirements for the modulator as well as make it possible to achieve a very large (\sim GHz) offset tuning range.

The measured performance of all three methods is similar and essentially identical to standard PDH to the level with which we have been able to measure in our setup. Figure 4 shows a comparison of the results with SSB locking and standard PDH (NOTE: need to either add another plot or generate one with all three curves shown). Also shown is a case where we deliberately added a modulation tone to the SSB control loop to show that the noise floor remains the same even while modulated, which is some indication that the tunability may be quiet when used as an actuator. The estimated shot noise level for this configuration is shown along with the estimated cavity thermal noise level [10]. In this case the modulation depth was not optimized, so the shot noise level is higher than it would be under ideal conditions. Therefore it is clear that in principle the thermal noise in the cavity will be the limiting noise source in the LISA measurement band, not the shot noise from the stabilization technique.



The fact that the measured performance of all three stabilization methods is similar and the same as the standard PDH technique suggests that the limiting noise sources are common in our setup. At frequencies below 10⁻⁴ Hz (not well shown in Figure 4) we believe we are limited by environmental temperature fluctuations filtered through our isolation system and we get good agreement between our model and measurements. A more complete noise model for other frequencies is under construction.

Figure 5. Experimental setup for arm-locking

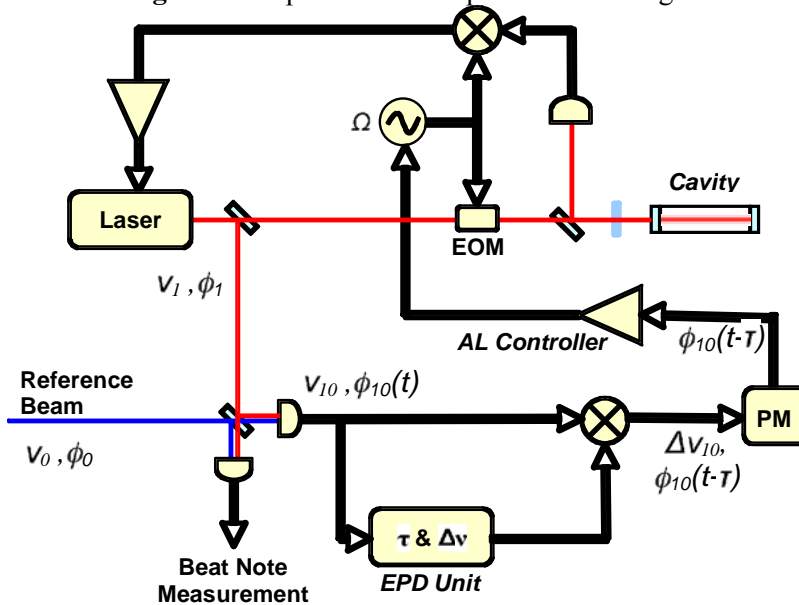

4. Application to arm locking

We have applied the frequency tuning capability as an actuator for an arm-locking control loop using the setup shown in Figure 5. The beatnote formed by mixing the frequency-tunable laser with a separate laser locked to a fixed reference cavity is used to generate an error signal that is applied to the reference oscillator that serves as the tuning mechanism for the laser. The error signal from the beatnote is generated using an electronic phase delay (EPD) technique[11] developed at the University of Florida that simulates the transfer function of a single arm. The same technique may also be applied to synthesizing the response functions of other arm-locking methods [12].

Figure 6. Measured single arm locking transfer function as implemented with the EPD technique and a 1 second delay.

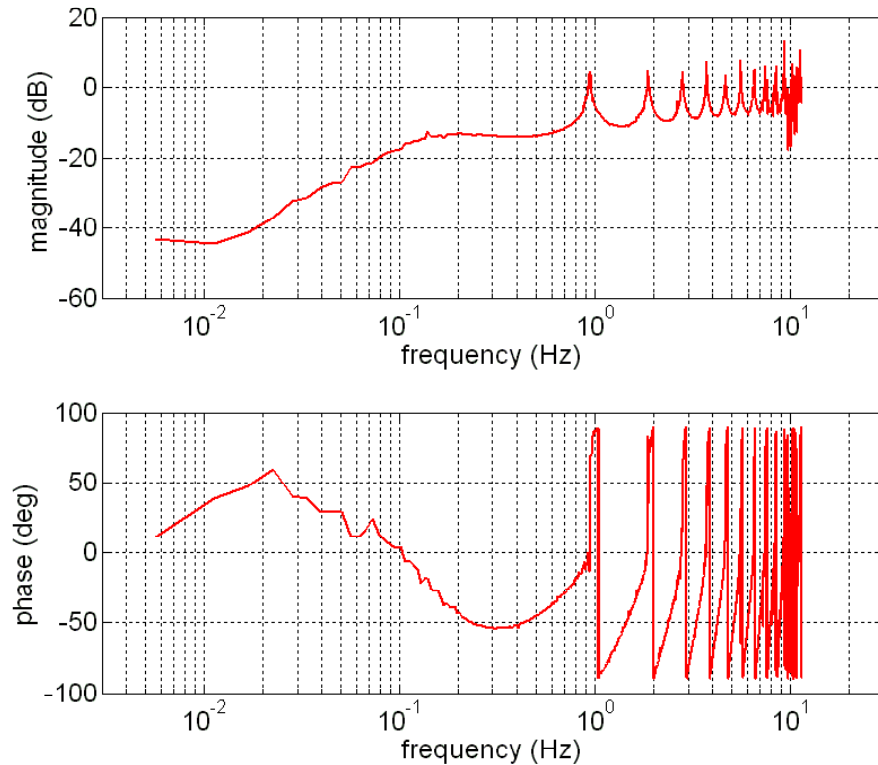

The measured response of the arm locking transfer function is shown in Figure 6 for a one second EPD filter. The characteristic shape of a single arm is apparent, and the expected noise suppression is ~ 40 dB at 10 mHz.

The corresponding measured frequency noise of the beatnote is shown in Figure 7 along with the measure free-running laser noise and an estimate of the free-running noise of the laser. Not shown on this plot is the pre-stabilized noise level because it could not be easily measured simultaneously while arm-locking, but a separate measurement indicates that the level of noise suppression is consistent with measured transfer function.

Further optimization is required to meet the requirements for LISA, but those requirements are best met with direct or dual arm-locking [ref]. These results demonstrate that the frequency tuning method we have developed is compatible with arm-locking near the required levels.

Figure 7. Preliminary arm-locking results

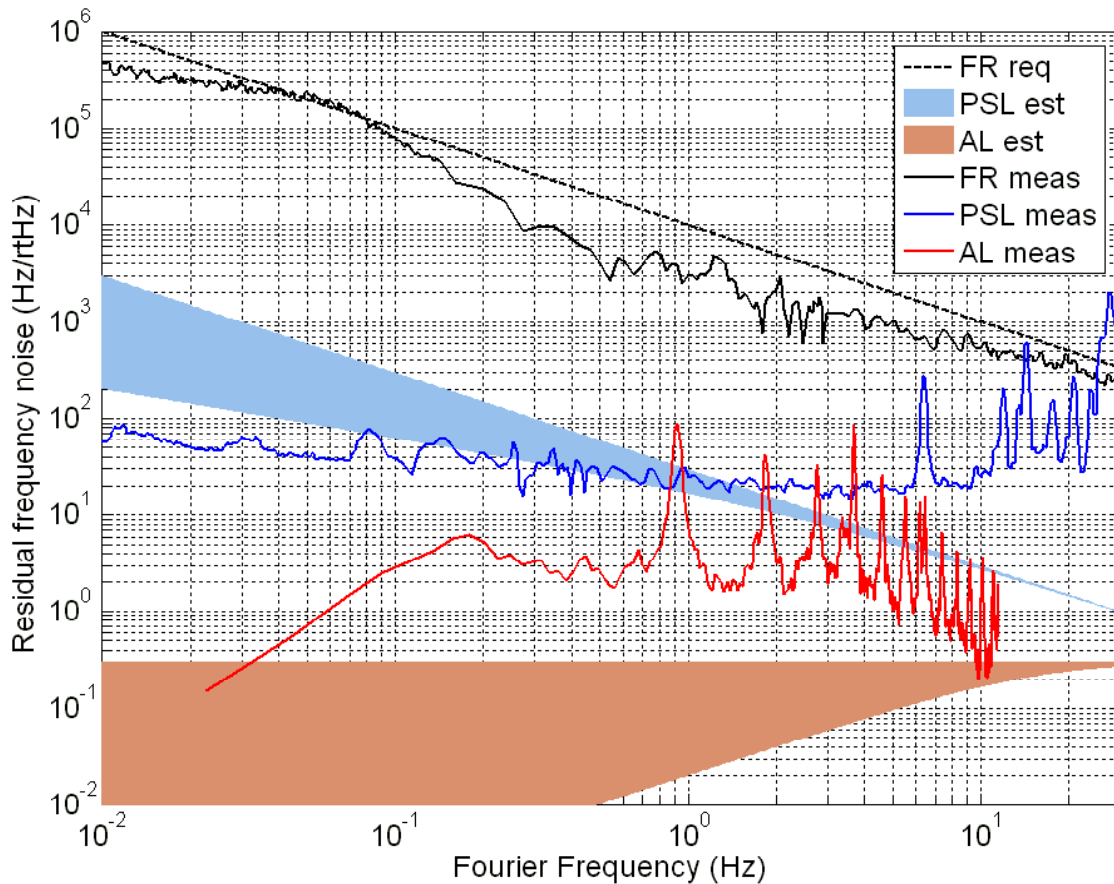

5. Conclusion

We have demonstrated a frequency-tunable laser source that requires minimal modifications to the standard Pound-Drever-Hall cavity locking technique and retains the noise properties of a fixed source to the accuracy of our laboratory setup. Furthermore we show that in principle an optimized tunable source will be limited by thermal noise in the reference cavity over the LISA measurement bandwidth, indicating that there is no performance penalty for the LISA application if this method for frequency tuning is implemented.

We have also applied this tunable capability as a frequency actuator for arm-locking and demonstrated the feasibility of the first two stages of a LISA frequency noise suppression scheme.

6. References

- [1] Bender P and Danzmann K and the LISA Study Team 1998 Laser Interferometer Space Antenna for the Detection of Gravitational Waves, Pre-Phase A Report Technical Report **MPQ233** Max-Planck-Institut für Quantenoptik Garching 2nd edition.
- [2] Shaddock DA and Ware Band Spero RE and Vallisneri M 2004 Post-process time delay interferometry for LISA *Physical Review D* **70** 081101(R)
- [3] Bondu F and Fritschel P and Man C N and Brillet A 1997 Ultrahigh-spectral-purity laser for the VIRGO experiment *Optics Letters* **21**(8): 582-584 1997
- [4] Conti L, De Rosa M and Marin F 2003 High-spectral-purity laser system for the AURIGA detector optical readout. *JOSA B* **20**(3): 462-468

- [5] Ye J and Hall JL 1999 Optical phase locking in the microradian domain: potential applications to NASA spaceborne optical measurements *Optics Letters* **24**(24): 1838-1840
- [6] R.V. Pound 1946 Electronic Frequency Stabilization of Microwave Oscillators *Review of Scientific Instruments* **17**(11): 490-505
- [7] Drever RWP, Hall JL, Kowalski FL, Hough J, Ford GM, Munley AJ, and Ward H 1983 Laser Phase and Frequency Stabilization Using an Optical Resonator *Applied Physics B* **31**(2): 97-105
- [8] Black E 2001 An Introduction to Pound-Drever-Hall Laser Frequency Stabilization *Am. J. Phys* **69**(1): 490-505
- [9] Thorpe JI, Numata K, Livas J 2008 Laser Frequency Stabilization and Control through offset sideband locking to optical cavities *Optics Express*
- [10] Numata K Kemery A Camp J 2004 Thermal-noise limit in the frequency stabilization of lasers with rigid cavities *Phys Rev Lett* **93**
- [11] EPD reference
- [12] Wand V 2008 (reference to arm-locking results in these proceedings or otherwise)
- [13] Sheard BS, Gray MB, McClelland DE and Shaddock DA 2003 Laser frequency stabilization by locking to a LISA arm *Phys. Lett. A* **320**(1) 9-21

Acknowledgement

This research was supported by an appointment to the NASA Postdoctoral Program at the Goddard Space Flight Center, administered by Oak Ridge Associated Universities through a contract with NASA.