

to 110 GHz. As shown in the lower part of Figure 2, the phase difference introduced by the switch remained within $\pm 10^\circ$ of the desired value of 180° over all but a small lower-edge portion of the frequency band from 90 to 110 GHz.

In a test of its performance as a balanced fundamental-frequency mixer, the circuit operated at a 12-dB conver-

sion loss, with an intermediate-frequency bandwidth of 25 GHz, at input frequencies from 78 to 110 GHz. This mixer performance is comparable to that of commercially available waveguide mixers, which, unlike this circuit, are not compatible with MMICs.

This work was done by Todd Gaier, Mary Wells, and Douglas Dawson of Cal-

tech for NASA's Jet Propulsion Laboratory.

This invention is owned by NASA, and a patent application has been filed. Inquiries concerning nonexclusive or exclusive license for its commercial development should be addressed to the Patent Counsel, NASA Management Office-JPL. For more information, contact iaoffice@jpl.nasa.gov. Refer to NPO-30916.

Generating Ka-Band Signals Using an X-Band Vector Modulator

Advanced modulations can be selected by programming an FPGA.

NASA's Jet Propulsion Laboratory, Pasadena, California

A breadboard version of a transmitter for radio communication at a carrier frequency of 32 GHz (which is in the Ka band) utilizes a vector modulator operating at a carrier frequency of 8 GHz (the low end of the X band) to generate any of a number of advanced modulations that could include amplitude and/or phase modulation components. The 8-GHz modulated signal is mixed with a 24-GHz signal generated by an up-converter to obtain the desired 32-GHz modulated output.

The transmitter is being developed as a prototype of downlink transmitters for transmission of data from spacecraft to Earth at high rates (>100 Mb/s). The transmitter design could also be adapted to terrestrial and Earth/satellite communication links. The advanced modulations (which can include *M*-ary phase-shift keying (MPSK), offset phase-shift keying (OPSK), and *M*-ary quadrature amplitude modulation (M-QAM). These modulations are needed because for a given amount of signal bandwidth, they enable transmission of data at rates

greater than those of older, simpler modulation schemes.

The transmitter architecture (see figure) was chosen not only to enable generation of the required modulations at 32 GHz but also to reduce the number of components needed to implement the transmitter. Instead of incorporating an 8-GHz signal source, the transmitter utilizes an 8-GHz signal generated by a voltage-controlled oscillator that is part of an X-band transponder with which the fully developed version of this transmitter would be used in the original intended spacecraft application. The oscillator power is divided onto two paths, one of which goes through the vector modulator, the other through amplifiers and a $\times 3$ frequency multiplier. Band-pass filters are included downstream of the frequency multiplier to suppress unwanted harmonics.

The in-phase (I) and quadrature (Q) components of the modulation are generated by use of a field-programmable gate array (FPGA) and fed through drivers to the vector modulator. The desired

modulation is selected or changed by programming the FPGA accordingly. Programming is controlled by use of an external computer connected to the FPGA via a universal serial bus.

The 24-GHz output of the frequency-multiplier path and the 8-GHz output of the modulator path are combined in a mixer to obtain the desired modulated 32-GHz signal. The performance of the mixer is improved by including an isolator in its output path. The isolator output is coupled through a 32-GHz band-pass filter to an output amplifier.

The transmitter performed well in initial tests, demonstrating capability for transmitting data at rates >100 Mb/s. In particular, data rates from 650 kb/s to 130 Mb/s were demonstrated using quadrature (quaternary) PSK and 16-QAM.

This work was done by Scott Smith, Narayan Mysoor, James Lux, Brian Cook, and Biren Shah of Caltech for NASA's Jet Propulsion Laboratory. For further information, contact iaoffice@jpl.nasa.gov. NPO-42995

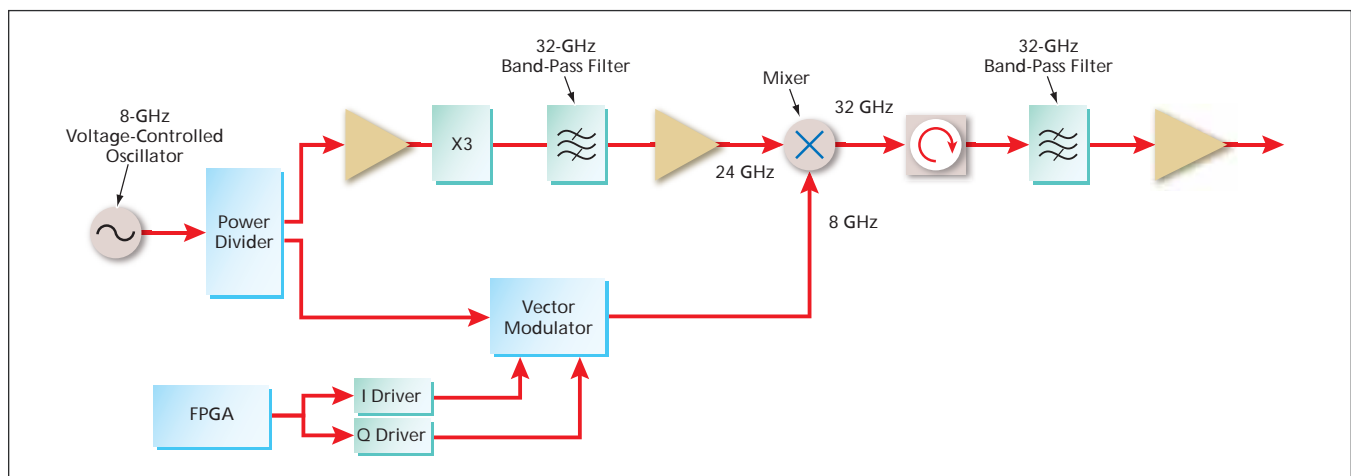

To Obtain a 32-GHz Modulated Signal, an 8-GHz signal is multiplied in frequency to 24 GHz along one path and modulated along another path, then the outputs of the two paths are combined in a mixer.