

# Orion Guidance and Control Ascent Abort Algorithm Design and Performance Results

Ryan W. Proud  
*NASA Johnson Space Center, Houston, TX 77058*

John R. Bendle  
*Lockheed Martin Corporation, Denver, CO 80201*

Mark B. Tedesco  
*NASA Johnson Space Center, Houston, TX 77058*

Jeremy J. Hart  
*NASA Johnson Space Center, Houston, TX 77058*

## Abstract

During the ascent flight phase of NASA's Constellation Program, the Ares launch vehicle propels the Orion crew vehicle to an agreed to insertion target. If a failure occurs at any point in time during ascent then a system must be in place to abort the mission and return the crew to a safe landing with a high probability of success. To achieve continuous abort coverage one of two sets of effectors is used. Either the Launch Abort System (LAS), consisting of the Attitude Control Motor (ACM) and the Abort Motor (AM), or the Service Module (SM), consisting of SM Orion Main Engine (OME), Auxiliary (Aux) Jets, and Reaction Control System (RCS) jets, is used. The LAS effectors are used for aborts from liftoff through the first 30 seconds of second stage flight. The SM effectors are used from that point through Main Engine Cutoff (MECO). There are two distinct sets of Guidance and Control (G&C) algorithms that are designed to maximize the performance of these abort effectors. This paper will outline the necessary inputs to the G&C subsystem, the preliminary design of the G&C algorithms, the ability of the algorithms to predict what abort modes are achievable, and the resulting success of the abort system. Abort success will be measured against the Preliminary Design Review (PDR) abort performance metrics and overall performance will be reported. Finally, potential improvements to the G&C design will be discussed.

# 1. BACKGROUND

---

NASA's Vision for Space Exploration calls for a long term exploration of the Moon, Mars, and beyond, with a focus on returning astronauts to the Moon by 2020. These goals require the development of a new spacecraft – the Orion Crew Exploration Vehicle (CEV). One of the primary design drivers for the CEV is to ensure crew safety. CEV requirements specify that abort capability should be continuously available from the launch pad until the mission destination is reached. Aborts during the critical ascent flight phase require the design and operation of CEV systems to escape from the Crew Launch Vehicle (CLV) and return the crew safely to the Earth.

Ascent phase aborts are characterized by large changes in vehicle altitude, large amplitude attitude maneuvers, and large vehicle center-of-gravity movement; and pose significant engineering challenges. Several ascent abort modes are being designed and analyzed to accommodate the velocity, altitude, atmospheric, and vehicle configuration changes that occur during ascent. These modes provide abort coverage extending from the launch pad until the CEV achieves a sustainable orbit. Analyzing these modes involves an evaluation of the feasibility and survivability of each abort mode and an assessment of the abort mode coverage using the current baseline vehicle design. Factors such as abort system performance, concept of operations, crew load limits, thermal environments, crew recovery, and vehicle element disposal are investigated to determine if the current vehicle requirements are appropriate and achievable. This paper presents an overview of the ascent abort G&C design and abort performance.

## 1.1.1. Nominal Ascent

For the PDR design cycle, the Rev. 5 CLV ascent trajectories were used to determine the capability of GN&C. These trajectories include IC's for ISS and Lunar missions, for various months of the year, and at multiple launch times in the available launch window, with varying performance of the engines, and varying assumed mass properties. When looked at as a whole, the entire set creates an envelope of the conditions that an abort must successfully function within. The abort envelopes are presented, along with the methods and assumptions used to obtain them.

### 1.1.1.1. Aborts Initiated from Dispersed No-Fail Trajectories

The set of CLV trajectories used is labeled Design Analysis Cycle 2, Revision 5 (DAC-2 Rev5). There are nine no-failure dispersed CLV trajectories. Each dispersion set consists of 2,000 runs. The simulations were performed with the NASA Marshall Space Flight Center (MSFC) 6 degree-of-freedom simulation MAVERIC (Marshall Aerospace Vehicle Representation in C). For PDR, CLV delivered a set of dispersed reference trajectories for both ISS and Lunar missions and at window open and close launch azimuths. Table 1.1.1-1 below shows the available trajectory sets. TD5-A and TD5-G were selected for ISS analysis to represent the close and open of the ISS launch window, respectively. TD5-C and TD5-D were selected to represent the close and open of the Lunar launch window. Additionally, analysis was performed with TD5-E to examine the effects of the low performance First Stage CLV on ISS abort capability.

Comment [RP1]: need LAS rev 4 words.

**Table 1.1.1-1 DAC2 Rev 5 CLV Dispersed Reference Trajectories**

Identifier	Vehicle	Mission	Month	Launch window
TD5-A	Light/Fast	ISS	August	Close
TD5-B	Light/Fast	Lunar	February	Close
TD5-C	Heavy/Slow	Lunar	February	Close
TD5-D	Heavy/Slow	Lunar	February	Open
TD5-E	Heavy/Slow FS + Light/Fast US	ISS	February	Open
TD5-F	Light/Fast	ISS	February	Close
TD5-G	Light/Fast	ISS	July	Open
TD5-H	Light/Fast	Lunar	August	Open

The vehicle description refers to the mean values used for the dispersed runs. Light/Fast indicates the vehicle mass mean values were for a lighter configuration and the vehicle mean expected engine performance was high. Lunar indicates that the CLV trajectory is designed for a lunar mission, while ISS indicates that the trajectory is designed to go to the ISS. Heavy/slow and light/fast denote the weight and speed of the vehicle. The nominal LF ISS Aug Close (TD5-A) trajectory parameters are presented in Figure 1.1.1-1.

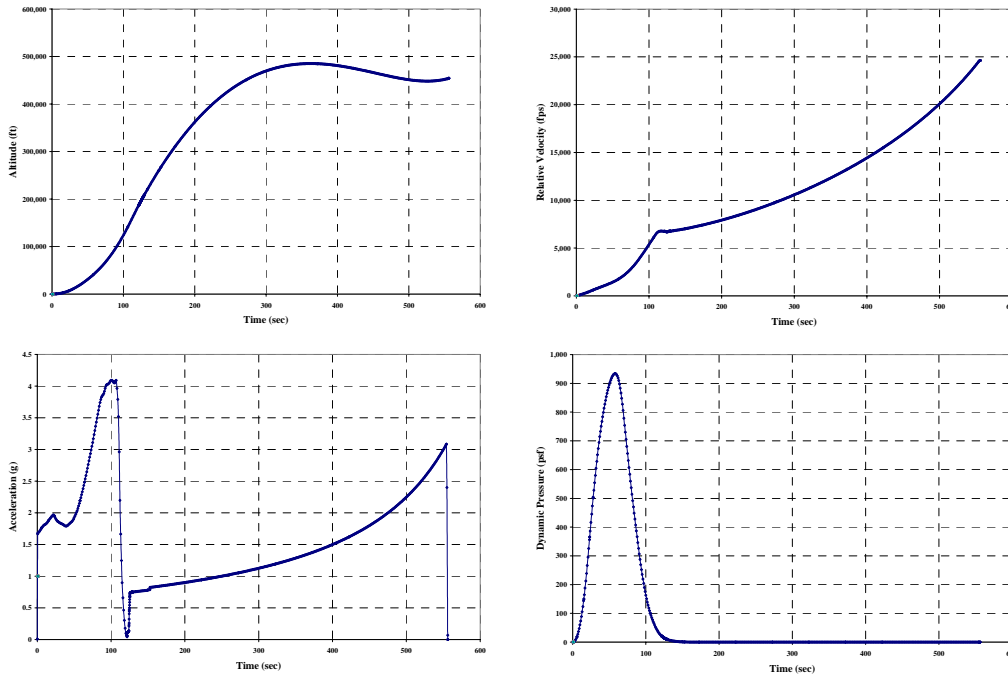

**Figure 1.1.1-1 Nominal LF ISS Aug Close CLV Trajectory (TD5-A)**

### 1.1.2. Integrated Aborts Overview

The CEV system is required to provide a launch abort capability from the launch pad after CM hatch closure throughout the CLV ascent until orbital insertion. The possible reasons for an ascent abort fall into one of three general categories: (1) a partial or total loss of CLV propulsion, (2) a loss of CLV control, or (3) a systems failure, either on the CLV or CEV, which results in the inability to safely achieve orbit. Several abort modes are required to accommodate the velocity, altitude, atmospheric, and vehicle configuration changes that occur during ascent. These modes provide abort coverage extending from the launch pad until the CEV achieves a sustainable orbit.

Mode I aborts, also referred to as Launch Abort System (LAS) aborts, are performed using the LAS and remain a viable option until the LAS is nominally jettisoned early in second stage. During Mode I aborts, the LAS abort motor is used to pull the Crew Module (CM) away from the CLV and Service Module (SM). Mode I aborts are characterized by high aerodynamic loads induced by low altitude maneuvers and high accelerations caused by the launch abort motor. LAS aborts may be commanded via the ground-based health management system, the on-board CEV Abort Decision Logic (ADL), the crew, or ground personnel.

Mode II aborts, also referred to as Untargeted Abort Splashdown (UAS) aborts, do not utilize the LAS. Instead, the CLV upper stage engine is shut down and the SM Reaction Control System (RCS) is used to provide adequate clearance between the launch vehicle and CEV. Once the CEV is sufficiently far away from the launch vehicle, the CM separates from the SM, and then the CM is maneuvered for a guided re-entry, and descends using parachutes to a safe landing location.

Mode III aborts, commonly known as Targeted Abort Landings (TAL), are triggered by late second stage failures where the CEV trajectory is modified via a targeted SM OME burn followed by a CM guided entry to a target landing site. The goal of these trajectory control efforts is to select a landing site that maximizes the chances of crew survival and recovery, while also meeting crew loads and SM thermal constraints. Due to the thermal environment associated with “drooping” into the atmosphere following an upper stage engine failure, the focus of the Mode III analysis is the droop altitude for various scenarios and the ways in which the droop effect can be minimized.

The last type of abort mode is Mode IV, which is an Abort To Orbit (ATO). This mode describes cases where an abort is performed following a premature shutdown of the upper stage when the SM has sufficient capability to achieve a safe orbit insertion and de-orbit burn. Similar to the TAL aborts, the ATO cases must protect the SM from adverse thermal conditions. For the Mode IV abort, the analysis looks at the amount of propellant (or  $\Delta V$ ) required to achieve a sustainable orbit, and similar to TAL, focuses primarily on the droop altitude effects.

## 2. LAS ABORT G&C DESIGN AND PERFORMANCE

---

### 2.1.1. Assumptions, Requirements, and Constraints

An abort is defined as the recognition of an intolerable situation that necessitates execution of actions and sequences required to terminate the mission, remove the crew from the hazardous situation, and safely return the crew to Earth. An ascent abort is by nature a highly dynamic maneuver, requiring safe and rapid departure from the launch pad or from a failing launch vehicle that is potentially experiencing high angular rates and off-nominal attitudes. Dynamic analysis of such an event necessarily involves a large number of assumptions and associated uncertainty bounds pertaining to vehicle characteristics, environments, and analysis methods. The assumed vehicle model and uncertainty ranges that were used for PDR analysis of the launch abort system dynamics are described in the following sections.

#### 2.1.1.1. Aerodynamic Database

The aerodynamic database that was used in the launch abort system dynamic analysis is discussed in this section. The CEV Aerosciences Project (CAP) is responsible for both the aerodynamic and aerothermodynamic design databases, which are Government-furnished products. The aerodynamic database that has been used to generate ascent abort PDR analysis products is version 0.41, as specified in the Orion Aerodynamic Data book [i].

#### 2.1.1.2. LAS Propulsion Systems

This section describes the LAS configuration propulsion systems that were used for PDR simulation assessments and analysis. The primary propulsion element of the LAS is the abort motor (AM), a solid rocket motor that provides escape thrust for launch aborts. The attitude control motor (ACM) is a controllable solid rocket that provides control torques to stabilize and maneuver the LAV during an abort. The jettison motor is a third solid rocket motor that is used to remove the LAS from the crew module during abort scenarios and during the nominal mission LAS jettison. The jettison motor is not described further as it doesn't effect the LAS abort G&C algorithm design.

#### Abort Motor

The launch abort motor provides the translational delta v required to pull the CM away from the ARES 1 launch vehicle in an abort. The LAS abort motor is a reverse-flow configuration, as illustrated in [Error! Reference source not found.](#) This configuration represents a significant departure from the Apollo design. One advantage of the reverse-flow abort motor concept is that it moves the nozzles away from the CM, reducing exposure of the crew module to the harsh environment of the AM thrust plumes. The abort motor nozzle directions, numbering convention, and nozzle locations can be seen in [Error! Reference source not found.](#)

Deleted: Figure 2.1.1-1

Deleted: Figure 2.1.1-2

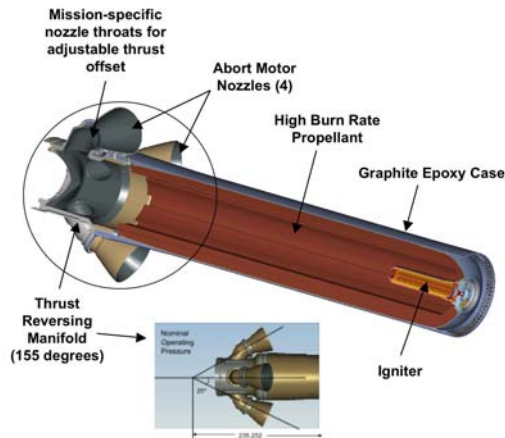

**Figure 2.1.1-1. Illustration of reverse-flow abort motor used in launch abort system.**

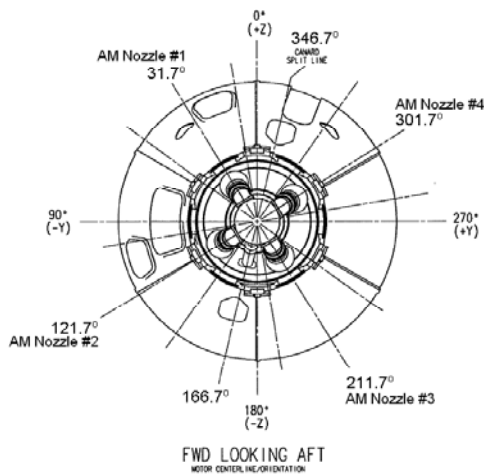
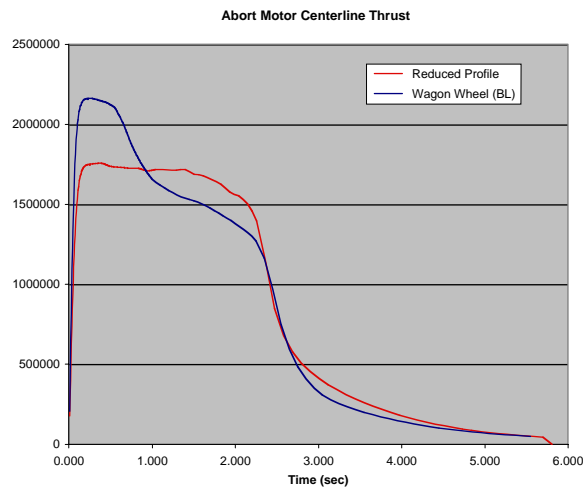

**Figure 2.1.1-2. LAS Abort Motor Nozzle Numbering (from [ii])**

The thrust profile for the LAS abort motor was the subject of an extensive trade study that is documented in detail in T-009 CEVLM-04-1033. The trade study recommends the use of a modified abort motor thrust profile that reduced the peak thrust level from the original baseline design, but increased the sustained thrust level while maintaining the same total impulse. This modified thrust profile was accepted as the outcome of ERBs 08-0174 and 08-0191.

Figure 2.1.1-3 shows a comparison of the original “Wagon Wheel” baseline thrust profile with the ERB-approved design change. This trade was influenced by driving requirements pertaining to the LAV/CLV separation distance performance and the pad abort water landing and descent rate performance.

Deleted: Figure 2.1.1-3



**Figure 2.1.1-3. Comparison of original baseline abort motor thrust profile (blue) with the modified profile recommended by trade study (red).**

### Attitude Control Motor

The primary control effector for the active LAS design is the attitude control motor (ACM) located near the top of the LAS tower. It is used to generate control torques during LAV flight after the abort motor has pulled the system off the ARES 1 launch vehicle in an abort scenario. The ACM's ability to generate pitch and yaw control torques is enhanced by the large offset from the LAV center of gravity. The ACM is based on a proportionally throttleable solid rocket motor design that consists of a single combustion chamber feeding eight radially oriented nozzles with actively controlled throat areas. A conical plug (pintle) is moved in or out of each throat to adjust independently the distribution of thrust among the eight nozzles, thereby altering the resultant directed thrust vector. The magnitude and direction of the ACM thrust vector are calculated based on the pitch and yaw moment commands from the active LAS control law. Details of the pintle valve control and ACM nozzle arrangement are illustrated in [Error! Reference source not found.](#)

Deleted: Figure 2.1.1-4

The ACM motor provides a boost/sustain thrust profile that is designed to deliver a minimum of 31,136 N (7,000 lbf) of omni-directional commanded vacuum thrust from 0 to 7 seconds, followed by a period from 7 to 27 seconds at a minimum of 11,120 N (2,500 lbf) of omni-directional commanded vacuum thrust. At 27 seconds, the LAS is jettisoned, and the ACM thrust profile tails off to a complete burnout at 30 sec. In pad abort scenarios, the LAS is jettisoned at 18 seconds instead of 27 seconds. In these cases, the ACM will still be thrusting at LAS jettison, but the thruster pintles will be positioned to null the propulsive torques acting on the LAV. The earlier LAS jettison for pad aborts is part of the accelerated event sequencing that is required to ensure adequate time to complete the LRS deployment prior to CM touchdown.

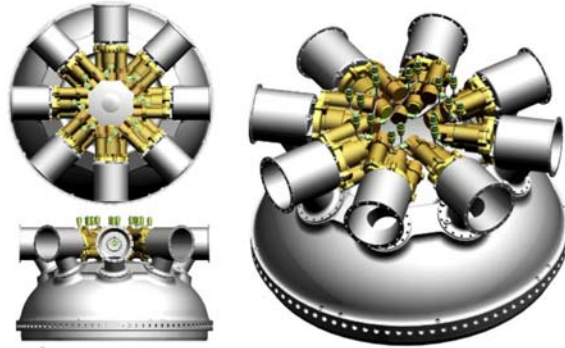

**Figure 2.1.1-4. Illustration of the pintle valve control and ACM nozzle arrangement. (from iii).**

### **2.1.1.3. Driving Requirements**

In this section, the primary driving requirements for the LAS GN&C are described along with a discussion of how they impacted the GN&C design.

#### **2.1.1.3.1. Abort Landing Descent Rate**

This driving requirement states that the GNC shall orient the CM at touchdown with the -Z axis (TBR-GNC-095) in the Earth-relative velocity direction to an accuracy of  $\pm 30$  deg (TBR-GNC-096) for ground speeds greater than 3 m/sec (9.84 ft) (TBR-GNC-097) under the conditions identified in tables: a) “Contingency Land Landing Conditions (TBR-CM-026)” b) “Water Landing Conditions Table (TBR-CM-030)” This is traced to attitude control during descent and landing, water landing, and may be also to LRS-GNC IRD.

The Abort Landing Descent Rate requirement primarily influences the trajectory design for pad aborts. Technically, LAS GN&C cannot directly reduce the vertical velocity of the CM at touchdown, but it can provide a pad abort trajectory that allows the landing recovery system sufficient time to do so. This effectively requires the LAS GN&C system to fly the launch abort vehicle along a trajectory that provides sufficient altitude at LAS jettison to allow a complete chute deployment sequence prior to touchdown such that a terminal descent rate of less than 10 m/s (33 fps) is achieved. This requirement is balanced against GNC.0638, which requires GN&C to command a pad abort trajectory that achieves a minimum landing water depth of 3.05 m (10 ft). To satisfy these requirements, and to ensure that the CM lands with sufficient distance from the launch pad, the LAS guidance commands a pitch maneuver at abort initiation that is intended to tilt the LAV abort trajectory toward the coastline. While a more lofted trajectory increases the likelihood of completing the chute deployment sequence prior to touchdown, a shallower trajectory will achieve greater downrange, increasing the likelihood of landing with sufficient water depth.



### 2.1.1.3.2. *Minimum Water Depth for Landing*

This requirement states that GNC shall command an abort trajectory that ensures the command module lands in a depth of 3.05 m (10 ft) water or greater with a 95-percent probability of success. The CM requires a minimum water depth at touchdown to avoid a hard impact that may compromise the CM structure or injure the crew on impact with the ocean floor.

The Minimum Water Depth requirement primarily influences the trajectory design for pad aborts. In order to avoid impact with the ocean floor during a pad abort water landing, the CM requires at least 3.05m (10ft) of water depth. The shortest distance to the ocean is from the KSC launch site (Pad 39B) is along a 53° azimuth from the pad (approximately perpendicular to the coastline.) Therefore, the launch abort guidance system commands an initial pitch maneuver that tilts the vehicle flight path toward the coastline along this 53° azimuth. This 53° azimuth pitch maneuver is also used during near-pad aborts, up to CLV abort initiation altitudes of 1,500 m (5,000 ft).

The other aspect of the guidance design that is influenced by the Minimum Water Depth requirement is the magnitude and timing of the initial pitch maneuver that is executed during a pad abort. This pitch maneuver is most effective in bending the LAV trajectory if it is executed during the most intense period of the abort motor burn, which covers the first 3 seconds of the abort. Performing the pitch maneuver as early as possible directs more of the abort motor impulse along the desired flight path. This approach is more effective than trying to bend the flight path aerodynamically by flying at a high angle of attack after the abort motor has burned out.

There is a trade between the altitude and the range that the LAV abort trajectory achieves, and this trade is largely controlled by the magnitude of the pitch maneuver that is conducted at the start of the pad abort. A milder pitch maneuver yields a more lofted trajectory, which provides more margin for the chutes to reach full deployment prior to touchdown, thereby improving the descent rate metric. But this improvement comes at the expense of the water depth metric. Other contributing factors in this trade are the event sequencing parameters that include the reorientation maneuver time and the LAS jettison time.

An illustration of the impact of pitch maneuver magnitude on pad abort performance is shown in [Error! Reference source not found.](#) This figure shows the LAS jettison footprint (yellow) and the CM touchdown footprint (magenta) for a pad abort dispersion using three different pitch maneuver magnitudes. The pitch maneuver command magnitude is increased by 6° increments from left to right, so that the most lofted abort trajectory is on the left. The variation in landing location is apparent in the figure. (This sensitivity was performed with a pre-PDR simulation version and is for illustrative purposes only.)

Deleted: Figure 2.1.1-5

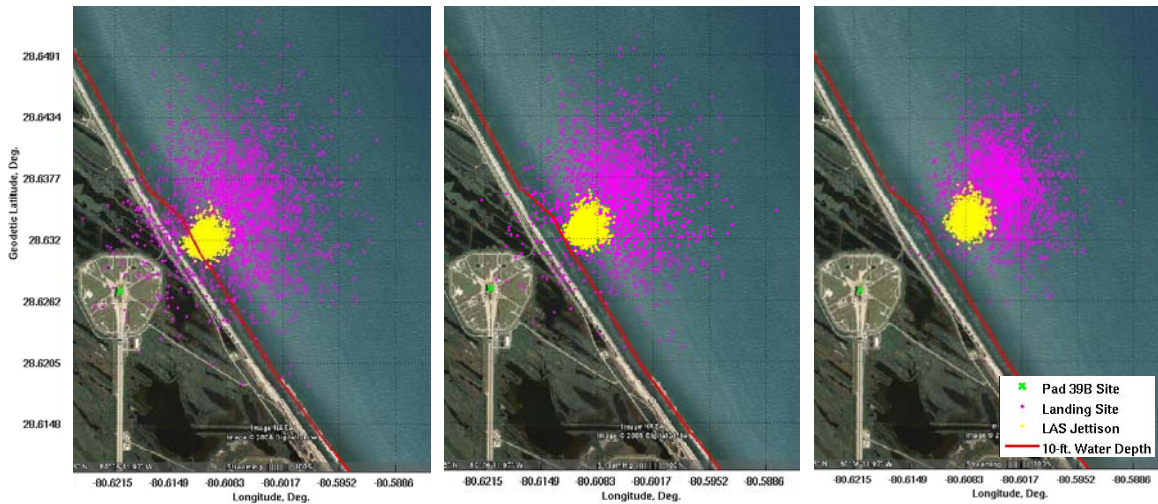

**Figure 2.1.1-5. Variation in pad abort water landing locations with increasing pitch maneuver magnitude.**

### 2.1.1.3.3. LAS Abort Separation Distance

This requirement states that GNC shall command an ascent abort trajectory, in the Launch Abort Vehicle configuration, that exceeds a minimum separation distance of 53m (175 ft), measured body to body, for ascent aborts during CLV first stage, relative to a CLV that is assumed to continue to accelerate along its planned trajectory, for all times greater than 3 seconds after abort motor initiation. Selection of a clearance margin from the nominal booster trajectory provides high success probability without requiring detailed analyses of all possible failed booster scenarios. “Body to body” means the straight-line distance between any two closest points of the LAV and CLV/SM. These points start out lying in the SM/LAV separation plane, but will be different points along the two body’s surfaces over time especially when the CLV/SM flies past the LAV after abort motor burn out.

The most challenging regime for meeting the separation requirement is the Mach 1 regime where the transonic aerodynamic drag is the highest. The short duration of the abort motor burn permits the LAV to achieve a limited forward and transverse separation distance before the high aerodynamic drag force begins decelerating the LAV. The trajectory of the much more massive CLV is inertially dominated, giving rise to the chance that a stable CLV will quickly close the distance, and re-contact the LAV.

An assumption that the CLV tumbles or diverges after the abort would be non-conservative, since it eliminates the possibility of an intact CLV re-approaching the LAV after abort motor burnout. Structural failure of the CLV would lead to many pieces of varying size traveling down range as they decelerate. The ballistic coefficient of these pieces will be much lower than that of an accelerating, intact CLV. Designing for the case where an intact CLV is assumed to continue to accelerate along its planned trajectory is a conservative approach that is mandated by the separation distance requirement.

The assumption that the CLV remains intact and will fly past the LAV at some point means that some form of separation maneuver is required to meet the separation distance requirement. The Orion launch abort system uses the attitude control motor (ACM) located near the top of the LAV to perform this maneuver. But overly aggressive separation maneuver can lead to the possibility of the LAV tumbling when the aerodynamic yaw or pitching moment exceeds the balancing torque capability of the ACM. Any tumble of the LAV during the high dynamic pressure portion of the abort is likely to cause structural failure. Maximizing the separation distance then involves finding the proper balance between the aggressiveness of the separation maneuver while avoiding tumbling at this critical time.

A comparison of [Error! Reference source not found.](#), [Error! Reference source not found.](#), and [Error! Reference source not found.](#) shows the improvement in the separation distance metric that resulted when the yaw steering command was increased to 4° and 10°. As can be seen in [Error! Reference source not found.](#), only one run fails with a minimum separation of 41 m (134 ft) when the 4° yaw steering command was used. The yaw steering also quickens the separation rate and slightly raises the minimum separation at the three-second mark. [Error! Reference source not found.](#) shows that there were no separation distance violations when the yaw steering command of 10° was used, and the minimum separation at three seconds was increased to 90.5 m (297 ft). This would be the obvious selection among the three if tumbling were not an issue.

Deleted: Figure 2.1.1-6

Deleted: Figure 2.1.1-7

Deleted: Figure 2.1.1-8

Deleted: Figure 2.1.1-7

Deleted: Figure 2.1.1-8

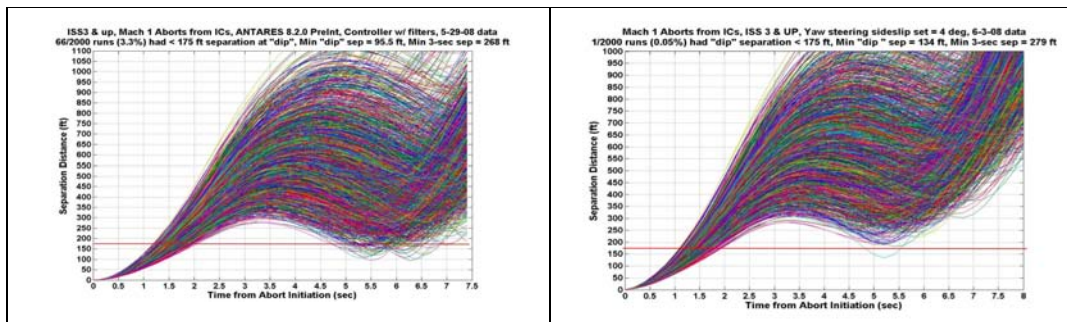

**Figure 2.1.1-6. LAV / CLV sep dist for no yaw steering maneuver.**

**Figure 2.1.1-7. LAV / CLV sep dist for 4° yaw steering command.**

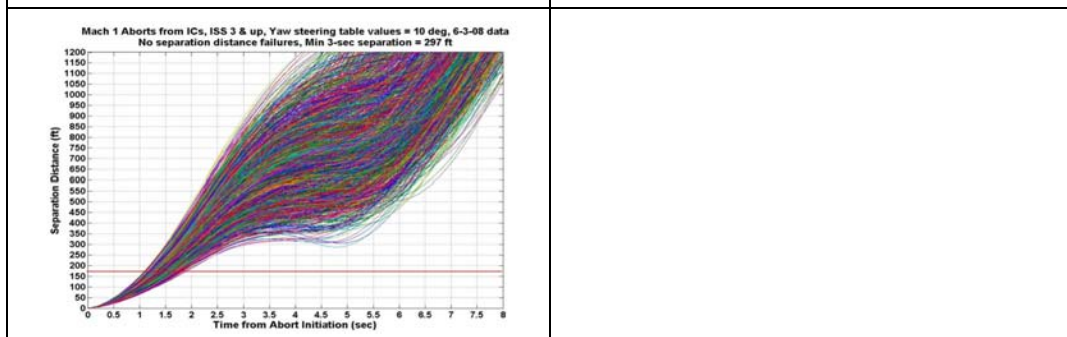

**Figure 2.1.1-8. LAV / CLV sep dist for 10°**

#### **2.1.1.3.4. Abort Initial Conditions**

This requirement states that GNC shall achieve its performance requirements when initiating an abort from both 99.7 percent of the dispersed no-fail CLV trajectories and 95 percent of the credible failures off dispersed CLV trajectories. This defines the initial conditions that will be used in all of the GN&C design work. The design must account for the dispersed no-fail day and the failed day. Credible failures are defined in the abort conditions report. Currently, the most credible failures are a CLV actuator fail in place and a CLV actuator fail to null. Out of all of the IC's the CEV GN&C system must show that 95 percent of the cases are successfully within the performance metrics.

#### **2.1.1.3.5. Landing and Recovery System Deployment Constraints**

There is a requirement that states GNC shall provide CM attitudes and rates at chute deploy as specified in the CM Attitude and Rates at Drogue Parachute Deploy Table and CPAS Initial Deployment Envelope Figure per the GNC IRD (CEV-T-035209). [CM.0851] Specifies the required CM attitudes and rates for successful LRS deployment.

The LRS deployment constraints impact the GN&C design by imposing limits on CM attitudes and rates immediately following LAS jettison. The LAV must reorient to a heat-shield forward flight condition prior to LAS jettison to leave the CM in an appropriate attitude for LRS deployment. An "all-attitude" LRS deployment capability might obviate the need for this complex large-amplitude reorientation maneuver altogether. The LRS drogue chute deployment constraints for the Gen-2 chutes are as stated in section 2.2.6:

- Mach  $\leq 0.8$
- Angle-of-attack (a) :  $130^\circ \leq a \leq 230^\circ$
- Angle-of-sideslip(b) :  $-50^\circ \leq b \leq 50^\circ$
- Roll Rate(p) :  $p < 120 \text{ deg/sec}$
- Dynamic Pressure(qbar) @ Line Stretch :  $478.8 \text{ Pa (10psf)} \leq qbar \leq 7900 \text{ Pa (165 psf)}$

The desire to leave the CM in a stable and quiescent heat-shield forward condition at LAS jettison in preparation for LRS deployment has driven the GN&C design concept in several respects. First, it has resulted in a notable departure from the Apollo LES concept of operation. The Apollo LES system was retained in all ascent abort cases until LRS deployment conditions were satisfied. But simulation analysis of the Orion CEV LAS indicated that excessive limit cycle oscillations could develop during the uncontrolled period of LAV flight following burnout of the attitude control motor after the reorientation maneuver was completed and prior to LRS deployment. The resulting dynamic condition at LAS jettison frequently caused the CM to violate LRS deployment tolerances, often tumbling. The LAS abort concept of operation was therefore defined to jettison the LAS at ACM burnout, which occurs 27 seconds after abort

initiation. If the Mach Number is greater than 0.8 at LAS jettison, the entry controller is engaged to use CM RCS to maintain a stable heat-shield forward CM attitude for the remaining period of descent until the drogue deployment tolerances are satisfied. This concept of operation was approved by an engineering review board that was convened in February of 2007 (ERB-07-0029).

#### **2.1.1.3.6. LAV First Bending Mode Frequency During Aborts**

This requirement states that in the Launch Abort Vehicle configuration, the Crew Module shall provide abort control to a nominal first bending mode free-free frequency of 7.0 Hz (TBR-SC-00148) with dispersed values within  $\pm 20$  percent (TBR-SC-00148) at abort motor initiation, after which time the bending frequency may increase, but will not decrease during the abort flight. This requirement defines the flexibility of the structural components that comprise the Launch Abort Vehicle.

The LAV bending mode shapes and frequencies drive the LAS abort control algorithm design because they limit the achievable control system bandwidth and make achieving required stability margins challenging. The relevant driving requirement is as follows:

**Control System Gain Margin:** The GNC subsystem shall provide for decoupled body axis pitch and yaw nominal control loop rigid body gain margins of at least 6dB nominal, 3dB 3-sigma dispersed, and for flexible modes, gain margins of at least 12dB nominal, 3dB with 3-sigma dispersion.

The autopilot design incorporates a gain stabilization approach to structural mode attenuation, using low pass filters to roll off the loop gain at the flexible mode frequencies. The flexible mode gain margin requirement (12 dB nominal, 3 dB dispersed) leads to a design specification for the amount of roll off required from the filters. In the current design, the attitude rate filters give 33 dB of attenuation over a frequency band 4.7 Hz wide. The phase lag from the low pass filters has a very large impact on the system phase margin, since they lower the maximum value of system loop phase. In addition, the filters decrease the frequency at which the loop phase reaches 180°. This in turn lowers the achievable system bandwidth, since the rigid body gain margin requirement (6 dB nominal, 3 dB dispersed) sets an upper bound on the loop gain at this frequency. In order to somewhat ameliorate these two deleterious effects, the filters are designed to give maximum attenuation only over a limited band of frequencies, and an optimization approach is used to reduce the phase lag.

### **2.1.2. Concept of Operation**

An overview of the launch abort vehicle configuration is shown in [Error! Reference source not found.](#) The abort motor (AM) provides the propulsive impulse to remove the LAV from the SM and launch vehicle during a pad abort from a stationary condition or an ascent abort during accelerating CLV flight. The attitude control motor (ACM) provides control torques to stabilize, maneuver, and reorient the LAV during an abort according to commands from the launch abort guidance system. The jettison motor (JM) provides the necessary impulse to remove the LAS assembly from the CM following the reorientation maneuver during an abort. The LAS is jettisoned immediately after reorientation is complete and rates are damped. The JM is also used

Deleted: Figure 2.1.2-1

to remove the LAS assembly from the CM during a nominal CLV ascent shortly after 2<sup>nd</sup> stage ignition.

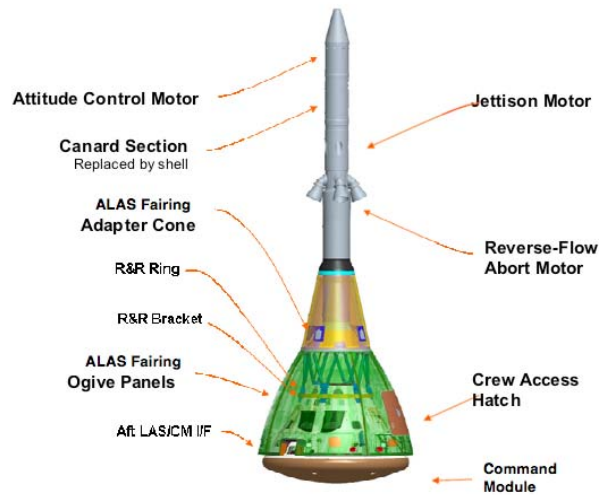

**Figure 2.1.2-1 Overview of Orion launch abort vehicle configuration.**

All aborts that make use of the launch abort system are collectively referred to as LAS aborts. Ascent aborts that are initiated after a nominal LAS jettison must use the service module for escape thrust, and are referred to as SM Abort. These are described in Volume 2B of the T-078 GN&C Design Databook. LAS aborts are divided into pad, low-altitude, mid-altitude, and high-altitude abort regimes, depending on the altitude at abort initiation. The LAS abort regimes are described in section [Error! Reference source not found.](#)

Deleted: 2.1.2.1

### 2.1.2.1. LAS Abort Regimes

[Error! Reference source not found.](#) provides an overview of LAS abort regimes and abort modes. Aborts due to a pre-launch emergency are referred to as pad aborts. During a pad abort, the abort GN&C system is designed to place the LAV on a trajectory that provides the shortest distance to the shoreline from the launch pad in order to achieve a water landing. The CM orientation on the launch pad is such that the crew launches and aborts in a heads down orientation. In a pad abort, the LAS delivers the CM to an altitude sufficient to deploy the Landing and Recovery System (LRS). The docking mechanism, either APAS to LIDS Adapter System (ATLAS) or Low Impact Docking System (LIDS), is removed from the CM at LAS jettison and remains with the LAS. Following LAS jettison, the LRS is deployed to slow the CM descent for a water landing. The CM does not perform a propellant dump during a pad abort as the CM structure is sized to accept landing loads with full CM propellant and Environmental Control and Life Support System (ECLSS) tanks.

Deleted: Figure 2.1.2-2

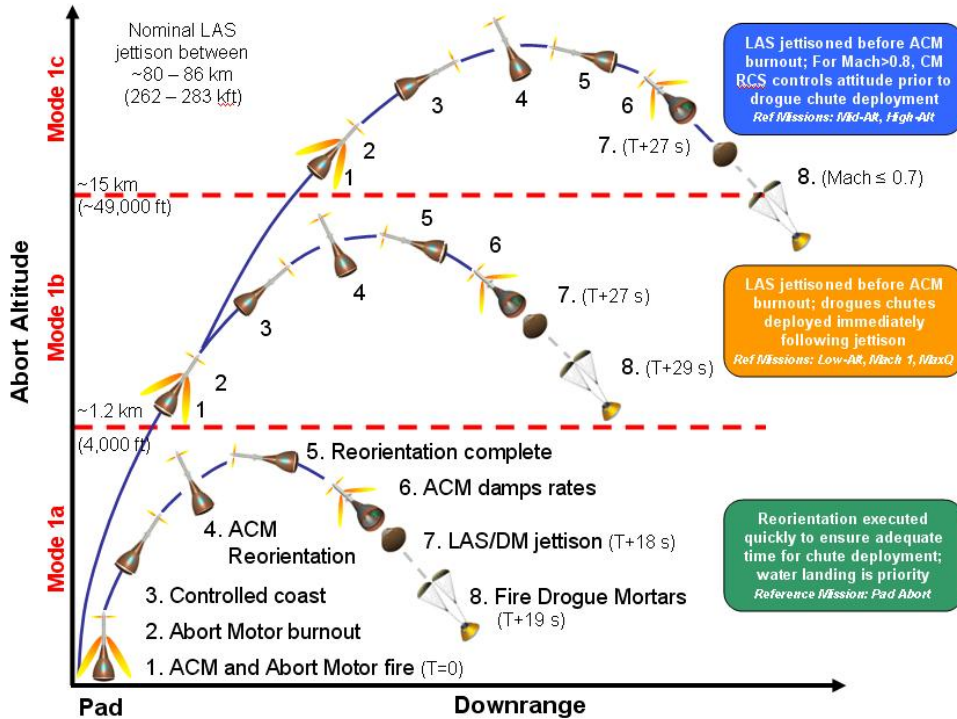

Figure 2.1.2-2 Overview of LAS abort regimes and flight phases.

**Error! Reference source not found.** illustrates the timing of each major event for each of the six design reference missions. The timing represents a nominal (non-dispersed) abort for one vehicle configuration, and is therefore only *representative* of the possible timing for each abort type.

Deleted: Table 3.2-1

Pad and near-pad aborts define Mode 1a. For these aborts, reorientation begins 12 seconds after abort initiation and LAS tower jettison occurs at 18 seconds to ensure enough time for proper inflation of the parachutes. Water landing is the primary guidance objective of Mode 1a aborts.

Mode 1b aborts are initiated between 1.2 and 15 km altitude. In these cases, reorientation doesn't begin until 15 seconds from abort initiation, and the LAS tower is jettisoned at 27 seconds, prior to ACM burnout. The 1.2 km division between Mode 1a aborts and Mode 1b aborts is contained within the flight software table parameters. Reorientation and LAS jettison times are determined at abort initiation by interpolating abort altitude vs. event time tables. Mode 1b drogue parachutes are deployed shortly after LAS jettison, as vehicle speed is below the Mach number requirement of 0.8 at the time of jettison. Maximizing the distance to the CLV is the primary guidance objective for Mode 1b aborts.

Mode 1c aborts are very similar to 1b aborts, except that following LAS jettison, the entry mode controller is engaged and the CM RCS fire to control CM attitudes and rates until the drogue deployment condition of Mach 0.8 is met. In addition, at very high altitude aborts, reorientation

may begin as early as 8 seconds after abort initiation because of the significantly lower dynamic pressure, and consequently structurally loading, at these altitudes.

**Table 3.2-1. LAS Abort Representative Sequence of Events**

<b>Event</b>	<b>Units</b>	<b>Pad Abort Mode 1a 0 km</b>	<b>Low Altitude Mode 1b 2.4 km</b>	<b>Mach 1 Abort Mode 1b 6.9 km</b>	<b>Max-Q Mode 1b 12.4 km</b>	<b>Mid-Altitude Mode 1c 21.3 km</b>	<b>High-Altitude Mode 1c 36.6 km</b>
<b>Abort Initiation; ACM/AM ignition</b>	sec	0.0	0.0	0.0	0.0	0.0	0.0
<b>AM Burnout*</b>	sec	5.2	5.5	5.8	5.8	5.8	5.8
<b>Start Reorientation*</b>	sec	12.0	15.0	15.0	15.0	15.0	8.0
<b>Reorientation Complete*</b>	sec	17.3	21.6	21.6	19.0	19.9	20.0
<b>LAS Jettison</b>	sec	18.0	27.0	27.0	27.0	27.0	27.0
<b>Drogue Chute Deploy</b>	sec	19.0	29.0	29.0	29.0	174.0	272.0
<b>First Drogue Disreef</b>	sec	N/A	44.0	44.0	44.0	189.0	287.0
<b>Second Drogue Disreef</b>	sec	N/A	58.0	58.0	58.0	203.0	301.0
<b>Main Chute Deploy*</b>	sec	24.2	64.0	133.0	208.0	283.0	386.0
<b>First Main Disreef</b>	sec	34.5	74.0	143.0	218.0	293.0	397.0
<b>Second Main Disreef</b>	sec	42.5	82.0	151.0	226.0	301.0	405.0
<b>Touchdown*</b>	sec	106	227	342	417	491	595

\*Timing is variable; AM burnout depends on temperature, motor variation, etc; Main chute deploy is dependent on altitude except for pad aborts; reorientation and touchdown timing is dependent on the environment

### **2.1.2.2. Post LAS-Jettison Flight Phases following LAS Aborts**

#### **2.1.2.2.1. Descent Using CM RCS**

During an ascent abort, if the Mach number is greater than 0.8 at LAS jettison, then the abort event sequencing logic engages the entry controller instead of immediately initiating the LRS deployment sequence. This procedure represents a departure from the Apollo precedent. The Apollo LES system was retained in all ascent abort cases until LRS deployment conditions were satisfied. Due to canard ineffectiveness, aborts initiated at altitudes greater than 30.5 km (100,000 ft) required an astronaut to initiate reorientation manually using the CM RCS thrusters. In contrast, the Orion LAS will automatically reorient the LAV using the attitude control motor, and then jettison the LAS and use CM RCS for the remainder of the descent until LRS deployment.

#### **2.1.2.2.2. Descent Under Chutes**

The descent and landing sequence, beginning at and including drogue parachute deployment and ending at vehicle touchdown, uses the same systems as nominal ISS and lunar entry. Volume 5, "Entry, Descent, and Landing", has a description of those systems and their use for entry application. The descent and landing sequence is shown below.



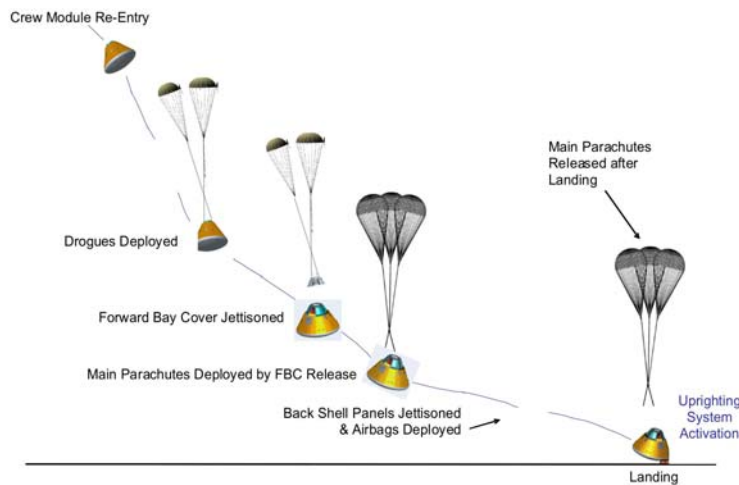

**Figure 2.1.2-3. Orion descent and landing sequence.**

Deleted: 9

### 2.1.3. Guidance System Design

Comment [RP2]: this whole thing should be a block diagram with words

#### 2.1.3.1. Design Overview

Guidance is responsible for performing two significant maneuvers during an abort. The first is a pitch over that begins immediately after the initiation of an abort and establishes either downrange distance or separation between the LAV trajectory and the launch vehicle trajectory. The second is a reorientation maneuver that occurs after burnout of the abort solid rocket motor and establishes a heat shield first attitude required for parachute deployment.

The guidance for these maneuvers uses a mixture of closed loop and open loop algorithms. Closed loop guidance can be used to improve downrange performance during low altitude aborts. Open loop guidance is used for all other aborts and is implemented by tables of steering commands computed prior to flight.

Guidance commands are provided by a command generator that supplies attitude and rate commands either based on open loop tables or as a function of the navigated velocity vector  $\mathbf{v}$ .

##### 2.1.3.1.1. Steering Table (Abort Horizontal Euler Angle) Command Generation

In this command generation algorithm open loop steering tables are used to specify the Euler angles of the transformation from the ah frame to the commanded body frame  $T_{bc/ah}$  (where bc refers to the *commanded* orientation of the body). Only pitch and roll angle commands are used. Thus we have  $T_{bc/ah} = [\phi_c]_x [\theta_c]_y$  where  $\theta_c$  is the tabulated value of pitch for the current value of time since abort initiation and  $\phi_c$  is the tabulated value of roll. The pitch angle command is obtained from a 3-dimensional table lookup.

#### **2.1.3.1.2. “Roll-stabilized” Angle of Attack and Sideslip Commands**

This steering strategy is used for high altitude aborts and after the first 2 seconds of a low altitude abort. The attitude command is formed by specifying desired angles of attack and sideslip for a hypothetical vehicle with zero AH roll angle (hence the designation ‘roll-stabilized’). The RS commands may be generated from open loop tables (Section 7.4.3.1) or calculated using a closed-loop guidance algorithm (Section 7.4.3.2). In either case, to preserve a consistent interface between steering commands and the attitude error calculation, an equivalent set of AH Euler angle commands is computed. The equivalent Euler angles are calculated in a two step calculation. First, yaw and pitch angles are calculated which align the body  $x$  axis with the velocity vector in the abort horizontal frame.

#### **2.1.3.1.3. RS Angle of Attack and Sideslip Commands from Open-loop Tables**

For high altitude aborts the angle of attack and sideslip commands are obtained from open loop tables which depend only on the initial conditions and time.

#### **2.1.3.1.4. RS Angle of Attack and Sideslip Commands from Closed-Loop Guidance**

For low altitude aborts closed loop guidance is used to form commands in terms of aerodynamic angles of attack and sideslip for a hypothetical vehicle with zero bank angle in the abort horizontal frame. This is done to insure that the angle of attack command directly influences the downrange distance traveled. The feedback signals also use the INS-measured Earth relative velocities transformed to the abort horizontal frame, in particular the  $x$  component of this vector gives the projection of the Earth-relative velocity in the downrange direction. A table lookup on time since abort initiation is used to create a desired downrange velocity command. The error between the desired and measured downrange velocities, plus its numerical integral times a gain, is used to form the angle of attack command via a three-dimensional table lookup.

#### **2.1.3.1.5. Body Angle of Attack and Sideslip Commands**

In later phases of the abort, the steering strategy changes. Commands are formed in terms of aerodynamic angles of attack and sideslip in the body, rather than in the roll stabilized frame. The table lookups are used after the first 8 seconds of a high altitude abort to smoothly ramp the commands from the initial commanded values  $\alpha_0$  and  $\beta_0$  at time  $t_2=0$  to null values 2.5 seconds later. The limited linear ramp in  $\alpha$  and null  $\beta$  command are used for the reorientation maneuver for all categories of aborts.

#### **2.1.3.1.6. Flight Path Angle Rate Feedback**

During the guidance mode described in this section, rate commands derived from an estimate of the flight path angle time derivative can be enabled. These rate commands are an aid in following angle of attack steering commands, since a constant angle of attack command in general does not correspond to a zero body rate command (because of changes in the flight path angle).

#### **2.1.3.1.7. Command Transitions**

In order to prevent significant response transients when switching between steering algorithms, it is desirable to blend the commanded attitude from the old to the new strategy. The kinematics for accomplishing this are described here.

#### **2.1.3.1.8. Measured Euler Angles to Commanded Euler Angles**

This transition takes place during the abort initiation phase. In order to prevent an excessive initial pitch over, the pitch steering tables are formulated to smoothly transition from an initial pitch angle  $\theta_o$  defined as follows in terms of the initial INS measurements.

#### **2.1.3.1.9. Euler Angles to Roll-Stabilized Alpha and Beta**

In order to smooth transitions from abort horizontal Euler angle commands (or measurements) to roll-stabilized angle of attack and sideslip commands as described in section [Error! Reference source not found.](#), an equivalent roll-stabilized angle of attack and sideslip command pair corresponding to the last set of Euler angle commands (or measurements) is calculated.

Deleted: 2.1.3.3.3

#### **2.1.3.1.10. Roll Command Override**

An overriding roll command is appended to the DCM or quaternion attitude command passed from the guidance section to the control section in order to keep roll errors small.

## **2.1.4. Navigation System Overview**

### **2.1.4.1. Navigation System Design Overview**

Orion will provide updates of the vehicle position, velocity, and attitude for all flight phases. For nominal ascent and ascent abort mission phases, absolute navigation will propagate an onboard state estimate with IMU measurement data.

The Orion navigation design concept is comprised of a highly accurate, fault-tolerant primary system and a Backup Emergency Capability (BEC) to be used in conjunction with backup manual crew procedures. The primary sensor suite includes three Inertial Measurement Units (IMUs), two GPS receivers, two star trackers, two laser-based Vision Navigation Sensors (VNS) and a docking camera (with one spare). These redundant sensors provide measurements to two Vehicle Management Computers (VMCs) via a fault tolerant, high-integrity time-tagged Onboard Data Network (ODN). Navigation software in the two VMCs process sensor measurements and maintain estimates of vehicle position, velocity, and attitude dynamics. Fault Detection Identification and Recovery (FDIR) is performed to detect and identify malfunctioning sensors and prior to incorporation of data into the navigation software. Finally, in the event of a primary systems failure, the BEC will ensure operability of the vehicle until recovery of primary systems or safe landing on Earth. Additional navigation capabilities will be provided in a Backup Flight Computer with independent connections to a primary IMU, GPS Receiver, and Star Tracker.

The navigation architecture is depicted in Figure 2.1.4-1.

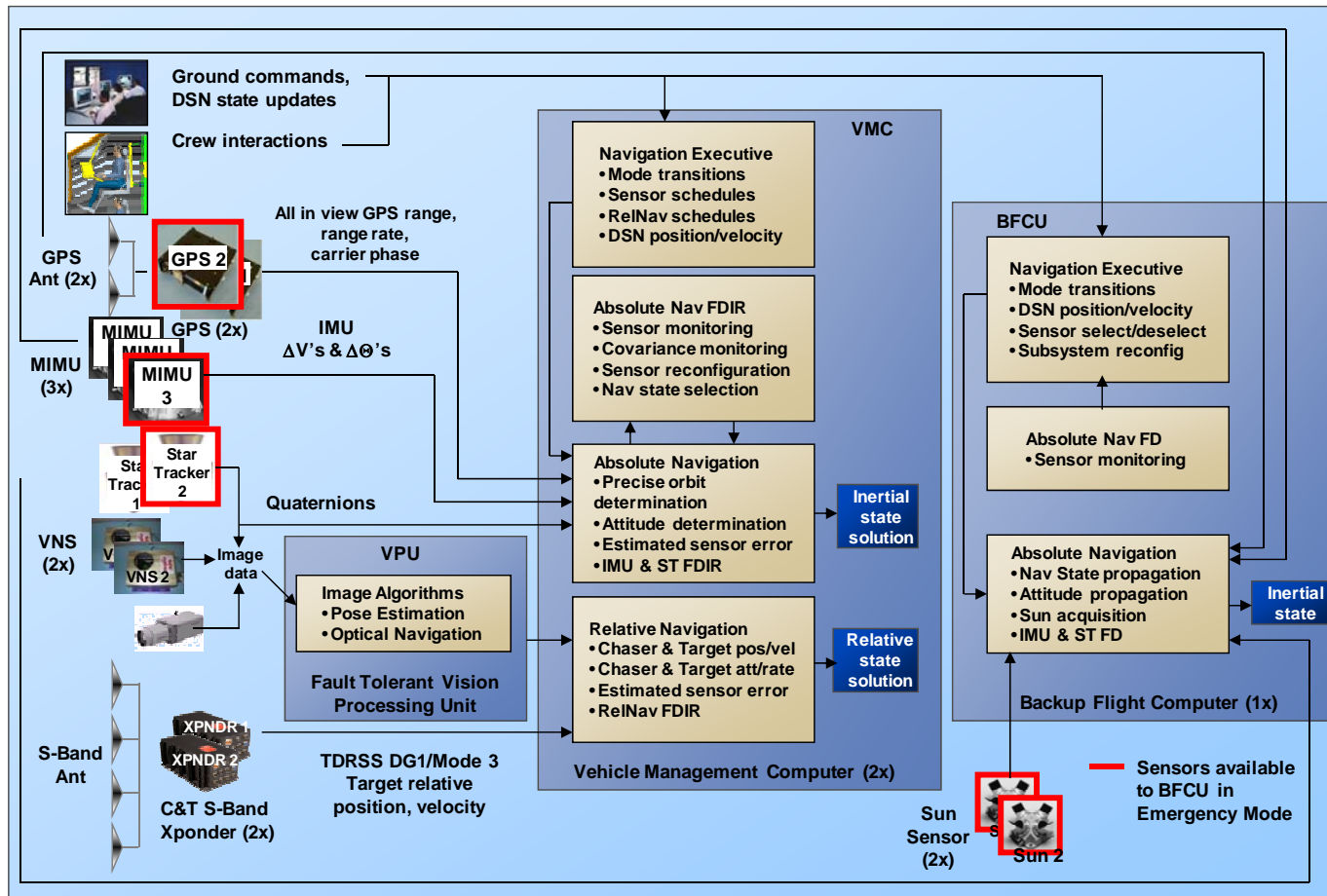

Figure 2.1.4-1. The Orion on-board navigation architecture.

During the safety critical ascent, ascent abort, descent, and landing mission phases, the IMU FDIR software will monitor three IMU's for faults and will also identify the best performing IMU. Three corresponding navigation solutions will be computed so that if an IMU fails there will be no dropout in navigation data. These solutions can also be compared to provide additional fault tolerance above and beyond the fault tolerance provided by the IMU FDIR. In contrast, the GPS measurements will go through a selection filter that will provide a single set of measurements to each navigation solution when available during entry, descent, or landing following LAS separation for abort scenarios. When a filtered solution is primary, an inertial-only solution will always be computed as a backup to protect against bad measurement updates.

#### **2.1.4.2. Navigation Concepts Of Operation**

Explain that we are IMU only during LAV flight. Future trades will determine if GPS should be added

#### **2.1.4.3. Navigation Performance**

Pick a plot from T-078. but only one.

### **2.1.5. Control System Design**

#### **2.1.5.1. Design Guidelines**

The top-level functional requirement for the LAS abort LAV control system is stated in the GN&C Subsystem Specification as follows:

- **Control LAV Attitudes and Rates.** GNC shall control the LAV attitude and attitude rate with the attitude control motor during LAS abort flight.

Because the LAV has no dedicated roll control effector, the control system controls only LAV pitch and yaw attitudes or inertial angle of attack and sideslip angles, depending on which phase of abort guidance algorithm is active. The LAV control system is designed to achieve two-axis control of pitch and yaw attitude and attitude rates in response to commands issued by the guidance system using the LAS Attitude Control Motor subject to the following performance and robustness requirements:

- **LAS Attitude Control Motor Usage.** GNC shall control the LAV (mated CEV and LAS) attitude using the LAS Attitude Control Motor with the attitude accuracies specified in table "Ascent Abort Attitude Accuracies".
- **LAS Jettison Condition – Attitude and Rates.** GNC, in the Launch Abort Vehicle configuration, shall provide Crew Module attitudes and rates at LAS jettison motor ignition as specified in the Attitudes and Rates for LAS Jettison table (TBR-GNC-135) (TBR-SC-00143).
- **Control System Phase Margin:** The GNC subsystem shall provide for decoupled body axis pitch and yaw rigid body control loop nominal phase margins of at least 30 degrees, and 3-sigma dispersed phase margins of at least 20 degrees

- **Control System Gain Margin:** The GNC subsystem shall provide for decoupled body axis pitch and yaw nominal control loop rigid body gain margins of at least 6dB nominal, 3dB 3-sigma dispersed, and for flexible modes, gain margins of at least 12dB nominal, 3dB with 3-sigma dispersion.

It was decided, at an early stage in the control system development not to attempt to actively damp (i.e., phase stabilize) any flexible modes due to the expectation that there would be large uncertainties in the predictions of the force delivered by the ACM. For example, the effects of control jet interactions with the flow over the rest of the LAV could significantly affect the generalized force exciting the modes. Therefore the autopilot design incorporates a gain stabilization approach, using low pass filters to roll off the loop gain at the flexible mode frequencies.

### 2.1.5.2. Algorithm Design

Figure 2.1.5-1 shows a simplified block diagram of the LAV GN&C system. The command generation block supplies attitude and rate commands either based on open loop tables or as a function of the navigated velocity vector  $v$ . The INS supplies estimates of the position vector  $r$ , velocity vector  $v$ , the attitude  $\theta$ , body rates  $\omega$ , and body acceleration  $a$ . The body rates  $\omega$  and attitude errors  $\theta_e$  are passed through bending filters to eliminate coupling between the autopilot and structural modes. An estimate of the flight path angle rate is calculated using the measurements of  $r$ ,  $v$ ,  $\omega$  and  $a$ . A control error calculation is made using the attitude commands and the attitude, body rate and flight path angle rate measurements. The control errors are passed to the control law. The control law uses gains calculated from tables of mass properties data to convert the control errors into actuator commands. The actuator commands are then sent to the ACM.

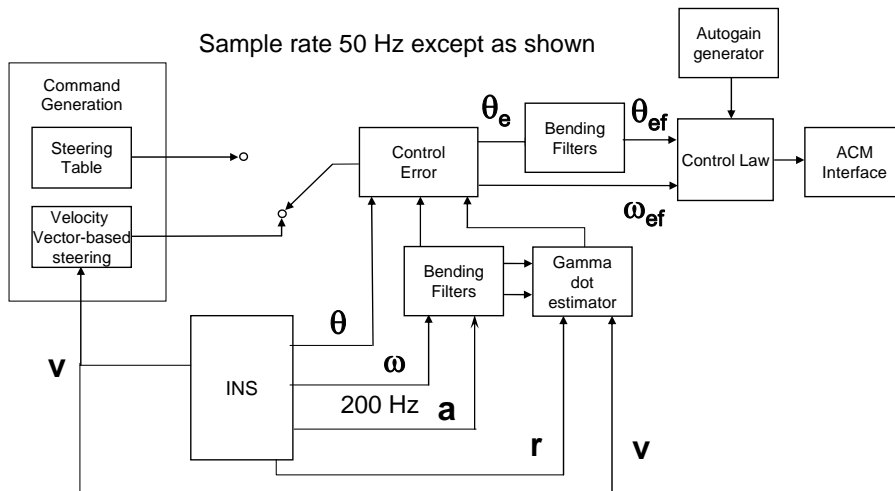

Figure 2.1.5-1. System Block Diagram

The pitch and yaw vehicle axes use similar uncoupled control laws, only the gain values differ from axis to axis. The following development will be shown for the pitch axis.

### 2.1.5.2.1. PID Architecture

The topology of the PID feedback control law is shown in [Error! Reference source not found.](#)

Deleted: Figure 2.1.5-1

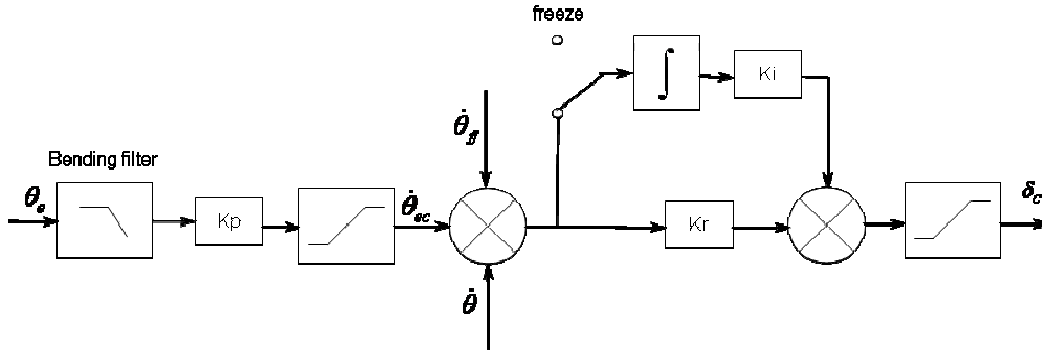

Figure 2.1.5-2. Control law block diagram.

The integrator acts on the inner loop. The switch at the input to the integrator is intended to indicate that the integrator is frozen when either saturation is active.

### 2.1.5.2.2. Roll-Yaw Coupling Crossfeed (p-Beta)

It is possible to control the vehicle roll attitude by commanding a body sideslip angle. While the outer mold line is nearly axisymmetric, the existence of a significant body  $z$  axis center of mass offset results in an effective  $C_{l\beta}$ . Given the roll attitude and rate errors calculated as described in earlier sections, an increment to the body  $z$  axis rate command is calculated. The rate command is added to the normal yaw axis rate command calculated as described in section 7.4.5.4.

## 2.1.6. LAS Abort Performance

The success rates for each dispersion case that was included in the PDR nonlinear simulation performance assessment are shown in [Error! Reference source not found.](#) The entries in the table show the percentage of runs that passed the complete set of performance metrics applied to a given scenario.

Deleted: Table 2.1.6-1



**Table 2.1.6-1. Overview of LAS Abort Success Rates**

CLV trajectories	Mission Configuration	Abort Scenario	CLV Trajectories						Chute Failure Scenarios	
			Pad Abort	Light-Fast, ISS Aug. Open	Heavy-Slow Due East Feb. Open	Light-Fast, Due East Jul. Open	Heavy-Slow, Due East Feb. Open	Light-Fast, Due East Feb. Close	One Drogue Chute Out	One Main Chute Out
<b>PDR Performance Assessment Overview:</b> <span style="color: green;">■</span> > 95% Success Rate for Combined Metrics <span style="color: yellow;">■</span> > 90% Success Rate for Combined Metrics <span style="color: orange;">■</span> < 90% Success Rate for Combined Metrics * Rock actuator fail to null, fail in place; Rock & Tilt fail in place ** Rock & Tilt actuators fail in place										
Nominal CLV Dispersed Trajectories	ISS-1,2	Pad Abort	95.9%						93.8%	98.6%
		Low Altitude(2,438.4 m)		98.8%	99.9%					
		Mach 1		78.2%	95.7%					
		Max. dynamic pressure		94.9%	99.5%					
		High Altitude		100%	100%					
	ISS-3 and up	Pad Abort	96.7%						89.5%	98.9%
		Low Altitude(2,438.4 m)		x	x					
		Mach 1		x	x					
		Max. dynamic pressure		x	x					
		High Altitude		x	x					
	Lunar	Pad Abort	95.4%						94.0%	98.3%
		Low Altitude(2,438.4 m)				99.7%	99.9%			
		Mach 1				86.0%	93.4%			
		Max. dynamic pressure				98.3%	99.0%			
		High Altitude				100%	100%			
Failed CLV Dispersed Trajectories	ISS-1,2	Low Altitude(2,438.4 m) *		99.5%						
		Mach 1 *		90.9%						
		Max. dynamic pressure *		94.0%						
		Mid Altitude (21,336 m) *		94.3%						
		High Altitude *		100%						
	ISS-3 and up	Low Altitude(2,438.4 m)		x						
		Mach 1		x						
		Max. dynamic pressure		x						
		Mid Altitude (21,336 m)		x						
	Lunar	Low Altitude(2,438.4 m) **						98.5%		
		Mach 1 **						87.5%		
		Max. dynamic pressure **						95.1%		
		High Altitude **						100%		

The success rates for each individual performance metric that contributed to these aggregate scores are presented in the following sections, but **Error! Reference source not found,** is intended to provide a broad overview that indicates the general level of compliance that the LAS GN&C design is currently delivering. The entries in the runs-for-record table are color coded to indicate aggregate performance requirement success rates greater than 95%, greater than 90%, and less than 90%.

Deleted: Table 2.1.6-1

**Error! Reference source not found,** indicates that the most stressing regime for the LAS aborts is the CLV Mach 1 flight condition. Total performance metric success rates were lower than 80% for some combinations of mission scenario and CLV trajectory cases at Mach 1. The majority of performance metric failures were due either to tumbling during abort motor firing, or to violations of the 1-second structural loading constraint on q-bar\*alpha. The light/fast trajectory cases tended to exhibit greater failure rates than the heavy/slow cases.

Deleted: Table 2.1.6-1

### **3. SM ABORT G&C DESIGN AND PERFORMANCE**

---

Service Module aborts are performed for vehicle failures that occur after the nominal separation of the LAS, which occurs around 30s after second stage ignition. The US of the CLV is a liquid fueled engine, which may be shutdown. Therefore, a specific abort vehicle, such as the LAS, is not required to separate the CM from the CLV.

SM abort modes are defined by the energy state and geographical location at the time of the Upper Stage engine failure in relation to desired landing areas or exclusion zones. Where overlap between modes occurs, priority is given to the mode that has the highest probability of successfully recovering the crew alive. Often, this mode also represents the most thermally and dynamically benign trajectory. Based on the initial conditions, several different types, or modes, of aborts are required. The following sections summarize the abort modes employed to provide continuous abort coverage.

#### **3.1.1. Assumptions, Requirements, and Constraints**

##### **3.1.1.1. DAEZ**

Orion is required to avoid the Downrange Abort Exclusion Zones (DAEZ) as defined in requirements GN&C.0152 and GN&C.0153. Coupled with the requirement for continuous abort coverage (CA0333-PO), this requirement is a strong driver of the vehicle propulsion system thrust magnitude. The DAEZ for ISS missions encompasses the region 277.8 km (150 nmi) east of St. John's, Newfoundland to 277.8 km (150 nmi) west of Shannon, Ireland. The DAEZ for lunar missions is still currently TBD, but is not expected to be a driver of the Orion propulsion system.

##### **3.1.1.2. HSIR**

Crew G-loads are defined in the Human-Systems Integration Requirements (HSIR) document. In this document, the G-loads are defined in terms of duration at G-load and the boundary for crew G-loads is larger for aborts than for nominal conditions. All abort scenarios have been verified against the HSIR and the worst G-loads experienced occur at the abort boundary for an ISS RTAL. The abort G-loads for an RTAL at the boundary are large; however, they are still below the HSIR abort boundary loads. UAS full lift-up and TAL have the most benign G-loading environments with UAS's near the DAEZ having larger G-loads as the bank angle increases, but still below the G-loads for an RTAL at the DAEZ.

##### **3.1.1.3. Minimum Altitude (Aerothermal)**

An additional altitude trajectory constraint is due to heating from the atmosphere. Despite the high altitudes involved with SM aborts there may still be enough heating to boil radiator fluid or melt hardware that is designed for use in the cold of space. For SM aborts, the OME is often utilized after separating from the CLV at a much lower altitude than it would be used nominally. In a TAL abort, the OME is burned to increase downrange capability so the CEV can reach the desired landing site. In an RTAL, the OME is used to decrease horizontal velocity and lower the flight path angle in order to steer the CEV back toward the designated RTAL landing site.

For TAL and RTAL aborts, the minimum altitude for OME operation is 121.9 km (400 kft). Below this altitude, SM OME functionality and overall vehicle structure are compromised due to aerothermal heating. After descending below 121.9 km (400 kft), the CM begins a sequence to separate from the SM and maneuver to a heatshield-forward orientation.

For AOA and ATO aborts, the SM OME burn altitude is limited to a more conservative 121.9 km (420 kft). This minimum burn altitude ensures that SM solar panels are not damaged from aerothermal heating during the droop phase of the ascent. All ATO aborts and some AOA aborts require functional SM solar panels for the remainder of the mission unlike TAL and RTAL aborts. Therefore, they have a higher minimum OME burn altitude.

#### **3.1.1.4. Minimum Altitude (Flight Control)**

Following the initiation of a Service Module abort, the Orion vehicle must perform a number of procedures in order to be properly configured for reentry. Currently, requirement GN&C 3.2.1.5.15 states that the GN&C system "shall achieve an angle of attack within 30 degrees of the trim angle of attack by 91.4 km (300 kft) altitude."

#### **3.1.1.5. Body Relative Motion Envelope**

For UAS and RTAL aborts, the motion of the jettisoned SM and DM relative to the CM was examined for all possible jettison angles in 7.5° increments (Technical Brief FltDyn-CEV-08-161 [iv] ) has the results for the PDR ANTARES configuration). This Monte Carlo study found that some jettison angles caused a high risk of re-contact, and many jettison attitudes resulted in jettisoned bodies moving back toward the CM. However, in an area centered on yaw = -135°, pitch = 0° in the Local Vertical Local Horizontal (LVLH) frame, the jettisoned bodies always moved away from the CM. For this reason, the jettison attitude of alpha=180°, beta=45° was selected as the nominal target.

#### **3.1.1.6. Abort Without Using CLV Thrust**

The design constraints just described must all be met without using CLV thrust throughout the abort trajectory. If aborts were to rely on the failed CLV to save the crew, then the probability of loss of crew would be too high to meet requirements.

### **3.1.2. Concept of Operations**

In order to meet GN&C requirements for ascent aborts, four abort modes have been designed. Mode 1 includes all aborts which involve the LAS. Mode 2, 3, and 4 aborts are SM Aborts which are divided by the effectors used (OME powered and non-powered) as well as the abort target (water landing or orbit).

#### **3.1.2.1. Untargeted Abort Splashdown (UAS)**

UAS aborts, also referred to as Mode 2 aborts, are the result of CLV Upper Stage engine failures that occur after the nominal jettison of the LAS and prior to reaching sufficient velocity to use the SM OME to thrust toward the Shannon, Ireland or Cape Verde recovery zones (designated abort water landing recovery zones for ISS and Lunar missions for PDR design analysis, respectively). UAS is the primary abort mode over the largest portion of the ascent

trajectory, from 30 seconds after second stage ignition (approximately 184 seconds mission elapsed time (MET)) to approximately 520 seconds MET.

UAS aborts do not require closed loop powered guidance, since the OME is not required to burn to reach a suitable landing zone. After US shutdown and tailoff, the CEV separates from the CLV, jettisons the Docking Mechanism (DM) and SM, and performs a controlled re-entry. The lift-up vector is chosen to minimize the g-loads felt by the crew during the abort mode at the expense of other metrics such as distance from search and recovery forces. For ISS mission UAS aborts, the landing zone is required to be no farther East than 277.8 km (150 nmi) from St. John's Airport in Newfoundland, Canada

Figure 3.1.2-1[Error! Reference source not found.](#) shows UAS abort landing sites at intermittent locations up the eastern coast for window open launches, shown in green, and window close launches shown in red. The times displayed refer to the MET at which the UAS abort was declared. The set of UAS aborts declared at 500 s MET fall within the 277.8 km (150 nmi) range to St. John. For Lunar mission UAS aborts, no explicit requirements exist with regard to splashdown location except that recovery forces must be able to retrieve the crew and capsule within 24 hours. Figure 3.1.2-2[Error! Reference source not found.](#) shows landing zones for UAS aborts initiated at various METs during 2<sup>nd</sup> stage ascent. These UAS aborts are flown at +/- 60 deg constant bank during entry in order to steer the CM back towards the centerline of the launch window. A notional SRB recovery ship is also shown, 463 km (250 nmi) off the coast of the launchpad. The SRB recovery ship could also be used for crew recovery in early 2<sup>nd</sup> stage abort scenarios.

Deleted: Figure 3.1.2-1

Deleted: Figure 3.1.2-2



Figure 3.1.2-1 ISS UAS Landing Zone

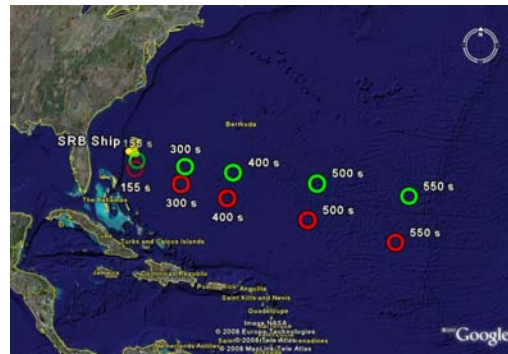

Figure 3.1.2-2 Lunar UAS Landing Zone

Error! Reference source not found. illustrates the UAS sequence of events while Error! Reference source not found. displays the timeline of the events. After a UAS abort has been declared and the US J-2X has been commanded to shutdown, the CEV transitions to a tailoff drift mode for 5 seconds to allow CLV thrust to decrease prior to initiating the separation sequence. Following the drift activity, a spring separation is performed, which is allotted 3 seconds to allow the OME nozzle to clear the spacecraft adapter. The spring separation is followed by an Auxiliary jet separation of 1.7 m/s (5.6 ft/s). This activity requires approximately 9 seconds depending on the vehicle configuration.



Figure 3.1.2-3 UAS Sequence of Events

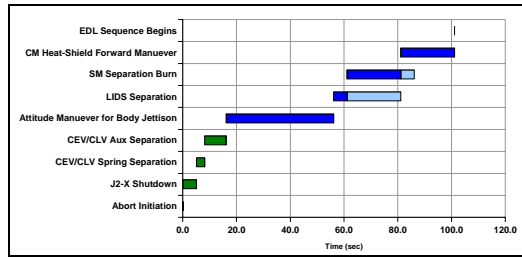

Figure 3.1.2-4 UAS Timeline of Events

Once the separation is complete, a re-orientation maneuver using the SM RCS thrusters establishes an attitude suitable for separation of both the docking mechanism and the SM. Due to the limited time available prior to entry into the denser layers of the atmosphere, a single attitude is employed for both jettisoned bodies. Once the attitude is achieved and the body rates have been damped, the DM is jettisoned using a spring mechanism. The DM is allowed to propagate away for 5 seconds. At the end of this time, the SM is jettisoned. The SM then performs an open loop -X RCS firing to back away from the CM. This burn is required due to the small separation impulse imparted by the SM pre-loaded structure separation, the lack of CM RCS jets which can push the CM away, and the short timeline available. This SM separation burn sequence is approximately 20 seconds. Until these separation events are complete, the CM RCS remains inactive. After the completion of the 20 second SM separation burn, the CM RCS system is used to attain a heat shield forward orientation and the entry sequence begins. The CEV/CLV, CEV/SM, and CEV/DM separation sequences are identical for each abort mode.

### 3.1.2.2. Targeted Abort Landing (TAL)

TAL aborts, also referred to as Mode 3 aborts, require firing the SM OME to change the velocity of the spacecraft in order to achieve landing near designated sites. TAL is the primary abort mode from approximately 520 seconds MET until Abort to Orbit (ATO) capability is achieved. The concept of operations for TAL and Retrograde Targeted Abort Landing (RTAL) aborts are the same with only the targets for the main engine burn varying. [Figure 3.1.2-5](#) **Error! Reference source not found.** illustrates each activity that must be completed for RTAL and TAL aborts. Essentially, the same activities must be completed for Mode 3 aborts, as those required for Mode 2 aborts, with the addition of the OME + Aux burn. The Aux thrusters are used in conjunction with the OME to increase the thrust-to-weight ratio and improve Mode 3 performance. During TAL entry, final phase guidance is flown to a point off the southern coast of Ireland. A typical TAL trajectory to Shannon, Ireland is shown in [Figure 3.1.2-6](#) **Error! Reference source not found.**

Deleted: Figure 3.1.2-5

Deleted: Figure 3.1.2-6

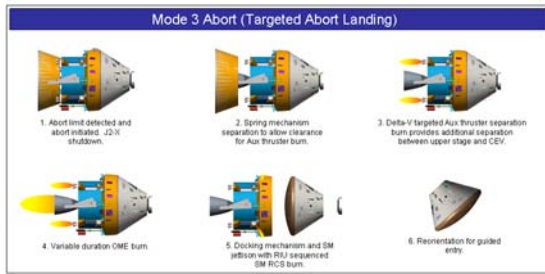

**Figure 3.1.2-5 Targeted Abort Landing Sequence of Events**



**Figure 3.1.2-6 Typical TAL Trajectory**

### 3.1.2.3. Retrograde Targeted Abort Landing (RTAL)

RTAL aborts, a class of Mode 3 aborts, are utilized for ISS missions between the end of the UAS window of opportunity and the beginning of the TAL window of opportunity in order to maintain continuous abort coverage without violating the DAEZ requirement. During this portion of the ascent, there is insufficient energy and SM propellant to use the OME thrust to reach a TAL site, but too much energy to remain on the western side of the DAEZ using entry lift control alone. For these cases, a small OME burn is performed to decrease horizontal velocity and lower the flight path angle. The cutoff constraints for the burn are a geodetic altitude of 121.9 km (400 kft) to limit aero-thermal heating or a predicted time of freefall to 91.4 km (300 kft) of 75 seconds to allow sufficient sequencing time prior to entry. During entry, RTAL employs a constant bank angle of -90 deg to reduce splashdown distance from St. John’s and meet the crew loads limits.

The separation sequencing, timeline, and landing site for RTAL aborts is identical to that of the UAS. The RTAL and TAL aborts, however, also perform a variable duration OME burn, as can be seen in [Figure 3.1.2-7](#). This burn occurs immediately after the Auxiliary separation event. The OME Thrust Vector Controller (TVC) is used to reorient the CEV to the desired burn attitude.

Deleted: Figure 3.1.2-7

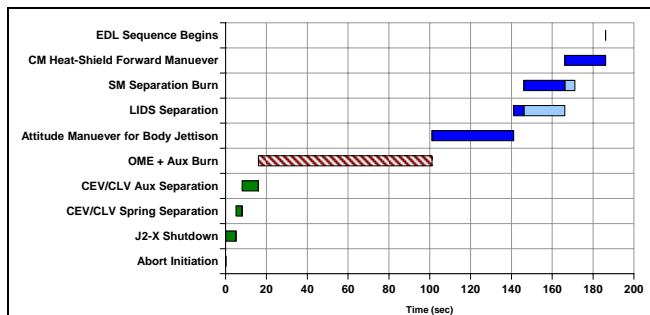

**Figure 3.1.2-7 RTAL and TAL Timeline of Events**

### 3.1.2.4. Abort To Orbit (ATO)

ATO aborts, also referred to as Mode 4 aborts, result when the US engine failure occurs late enough in the ascent trajectory that the SM has sufficient thrust and propellant to achieve sustainable orbit and subsequent deorbit. A first burn, using the OME and 8 Aux jets, to raise apogee to 185 km (100 nmi) and a subsequent burn, using the OME only, to circularize the orbit characterize these aborts. ATO is the primary abort mode from approximately 540 seconds MET until nominal shutdown of the second stage engine. [Figure 3.1.2-8](#) illustrates the ATO sequence of events. The ATO targets a final circular altitude of 185 km (100 nmi). This altitude is intended to provide a minimum 24 hour orbital lifetime which provides sufficient time to target a desired landing point and alert appropriate rescue and recovery forces.

Deleted: Figure 3.1.2-8

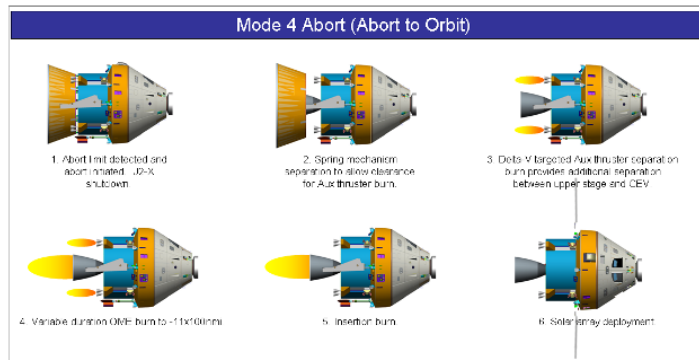

Figure 3.1.2-8 Abort To Orbit Sequence of Events

The ATO burn targeting and solar array deploy sequence were selected to match the nominal sequence as closely as possible. The ATO burns attempts to match the insertion apogee altitude, 185 km (100 nmi), and time, approximately 1500 seconds, of the nominal CLV insertion targets. This results in nominal procedures being applicable for ATO from CLV separation through insertion.

### 3.1.2.5. Abort Coverage

Comment [RP3]: consider moving or deleting

Requirement CA0333-PO dictates that the Orion shall have at least one abort mode available at any time throughout ascent. Coupled with the requirement to avoid the DAEZ (CA0579-PO), these requirements imply that one or more abort modes which result in a landing beyond downrange of the DAEZ (TAL and ATO) must become achievable before the capability to reach the regions west of the DAEZ expires. It is preferable to provide as much overlap of the abort modes as possible to maximize crew survivability in the event of an abort. This section outlines the work done to assess the abort coverage of the various modes. AOA is a post-MECO abort mode used to land in the Pacific Ocean off the coast of North America.

Abort coverage is characterized in terms of the instantaneous impact point (IIP) range from the launch pad at the time of abort initiation. IIP is a calculation of the latitude and longitude that the CM will impact with water assuming the default concept of operations for each abort mode. Previous iterations of this analysis have used mission elapsed time or inertial velocity magnitude as the characterizing factor. However, using MET does not factor in the energy state

of the vehicle at the time of abort. If the trajectory happens to be relatively “slow” or “fast” in comparison with the nominal ascent, this difference may result in the movement of an abort boundary by several seconds. Using inertial velocity helps to remedy this problem by factoring in the energy state of the vehicle at the time of abort initiation, and helps to reduce splashdown location dispersions. However, by using the IIP range to categorize the abort modes, additional data are taken into account at the time of abort initiation (velocity, flight path angle, altitude, latitude, longitude) that help to further refine the splashdown location of the vehicle. **Error! Reference source not found.** shows the general abort coverage available throughout all phases of ascent. **Error! Reference source not found.** shows the more specific abort coverage for the ISS Light/Fast Open July CLV trajectory including losses due to dispersions.

Deleted: Figure 3.1.2-10

Deleted: Figure 3.1.2-11

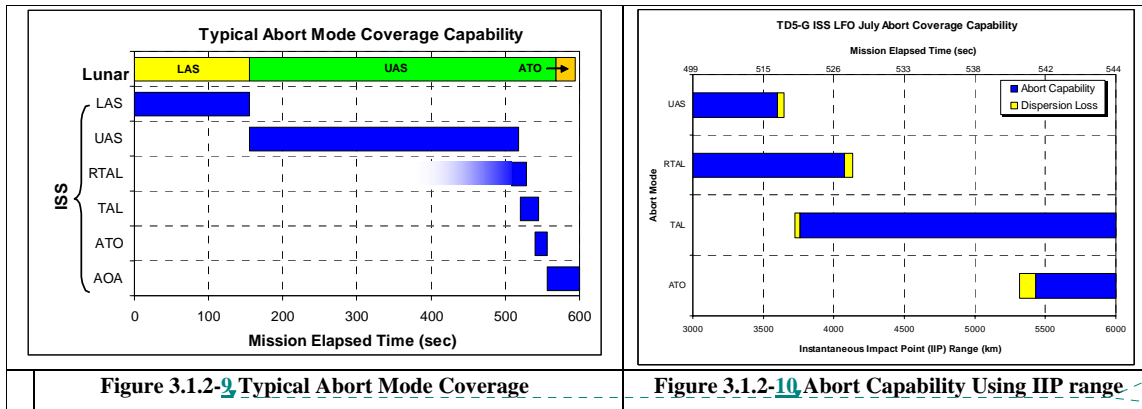

Deleted: 10

Deleted: 11

### 3.1.3. Guidance System Design

There are 3 guidance schemes used in SM abort. Open loop guidance is used for low complexity situations and is not described in any additional detail. Boost Iterative Guidance (BIG) is used for late ascent aborts that require accuracy in a burn completion state. Powered Explicit Guidance (PEG) is only used in aborts for OME burns on orbit.

#### 3.1.3.1. Boost Iterative Guidance (BIG)

The guidance algorithm employed for the TAL, RTAL, and first ATO burns is Boost Iterative Guidance (BIG). At its heart is a 3DOF equation of motion integration scheme, which is used to iterate on desired pitch attitude and burn duration to achieve a target burnout state.

BIG guidance iterates on both desired pitch attitude as well as final range. **Error! Reference source not found.** shows a block diagram of the pitch iteration method. The integrator is passed the current position, velocity, mass, and sensed acceleration. On the first pitch iteration, if guidance has not been run yet, the initial (minimum) thrust pitch attitude is selected. On subsequent guidance calls, the last pitch value from the previous call is used.

Deleted: Figure 3.1.3-6

This configuration is then integrated to the burnout mass target. Note that the thrust pitch attitude is constant during this integration. A study was performed to look at whether a pitch rate is beneficial during these burns. Very little benefit was seen during this preliminary study to



either final altitude or range. Further studies will be performed during CDR to verify that this constant pitch attitude is a sufficient design approach.

If the minimum altitude is achieved within a tolerance or the pitch is at the maximum or minimum limit, the burnout state is handed to the range iteration logic. For the former case, this indicates that the optimal pitch attitude to just barely achieve the minimum altitude has been found and no further pitch iteration is required. If the pitch is at a limit, this indicates that either (a) the energy state is very low and the upper pitch limit has been reached and further increases to the pitch will not improve droop or (b) that the energy state is high and the lower pitch limit has been reached and only range iteration is required.

For the second iteration, the pitch is perturbed by 0.02 radians and the trajectory is integrated to burn out again. A partial of change of pitch to change of minimum altitude is computed and then used to compute the pitch necessary to achieve the desired minimum altitude for the third and final iteration. If the altitude or pitch limit checks are not satisfied, BIG returns the current pitch attitude without running the range calculation.

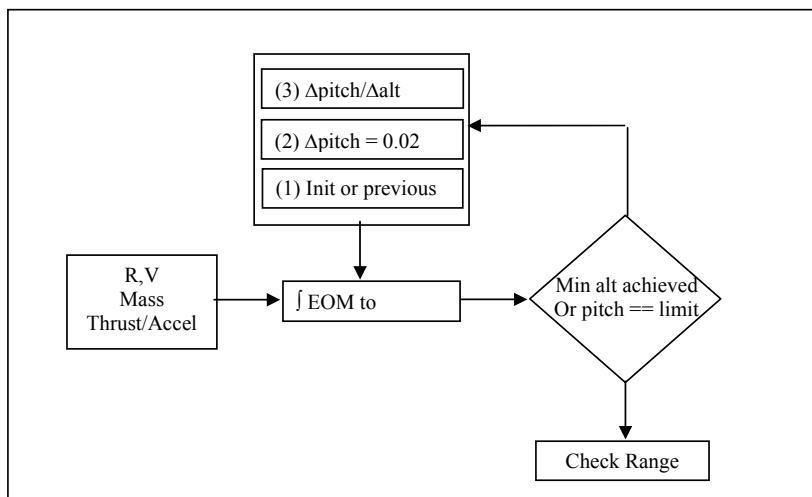
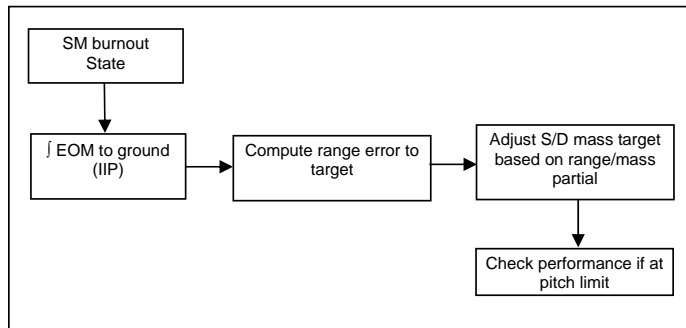

**Figure 3.1.3-1 BIG Pitch Iteration Logic**

Deleted: 6

Once either the altitude or the pitch limit check is satisfied, BIG begins iterating on a desired burnout mass to hit a range target. **Error! Reference source not found.** displays this portion of the algorithm. The vehicle state at the end of the SM burn is propagated in freefall to the ground and an Instantaneous Impact Point (IIP) is determined. This range is compared to a desired target range for a particular landing site. The range error is computed and scaled by a landing site-specific range gain term to convert the range miss to an adjustment in the desired burnout mass, the launch site in this instance.

Deleted: Figure 3.1.3-7



**Figure 3.1.3-2 BIG Range Iteration**

Deleted: 7

An additional iteration may be performed during the pitch determination if either the max or the min pitch limit has been reached. The intent of this logic is to determine if an alternate pitch attitude is available to decrease the range to the target or to reduce the propellant consumption required to reach the target. Early TAL cases, which use BIG, may benefit from additional pitch by extending the burn duration, since the burn will be shut down once the minimum altitude is reached. Later TAL cases may increase propellant margin by pitching down to achieve the range sooner as long as the minimum altitude is still maintained.

The maximum pitch limit is ideally set high enough to encompass the range of expected initial conditions. It is possible, however, that a higher pitch is optimal for a given initial condition. These cases adjust the 3 droop flyouts. The pitch for the second flyout is perturbed above the limit and a flyout is performed. If the resulting range miss is smaller than the previous flyout, the new pitch command is returned. If the higher pitch command results in an increase in the range miss, then the previous pitch command is returned.

The minimum pitch limit is selected as the optimal burn pitch attitude to increase IIP as efficiently as possible. It is possible, however, that a lower pitch attitude may provide improved efficiency for a given set of initial conditions. Therefore, if the current droop flyout is at the lower pitch limit, the second flyout will perturb the pitch below the lower limit and compute the propellant consumed to achieve the desired target. If this lower pitch results in an increase in total performance (Eqn 6.3.3-1), the lower pitch will be selected.

### 3.1.3.2. Powered Explicit Guidance

Powered Explicit Guidance (PEG) using a Linear Terminal Velocity Constraint (LTVCON) is the guidance algorithm used for both AOA deorbit as well as the ATO circularization burn. It is designed to solve a two point boundary value problem in which the initial conditions are provided and the cutoff conditions are known implicitly through a set of coasting equations related to the target conditions. This mode is intended for use in maneuvers in which the cutoff velocity is constrained so that the subsequent coasting trajectory passes through a specified target position vector with a specified linear relationship between the vertical and horizontal components of velocity at the target. The target conditions are the end-of-coast target position vector and the intercept and slope constants defining the target velocity constraint line.

A secondary guidance algorithm used for either deorbit or ATO contingency operations is PEG external delta-V targeting. This algorithm employs an open loop scheme that requires an external burnout velocity vector as an input. The thrust direction is determined by unitizing the burnout velocity vector and the burn shuts down when the magnitude of the velocity vector is zero. The ATO scenario where this algorithm could be utilized would be for the case in which system problems during Second Stage resulted in dispersed MECO conditions in which pre-flight computed PEG LTVCON targets provided a non optimal propellant burn solution. For this scenario, the crew would employ this capability to quickly target a perigee raising burn centered about apogee that would be tangential to the velocity vector instead of iterating on a set of PEG LTVCON targets to compensate for the dispersed MECO conditions.

**3.1.3.2.1. PEG Overview**

The version of PEG employed for CEV orbit insertion was obtained from the Shuttle PEG LTVCON Mode. The flow chart on the following page was adapted from the Shuttle Ascent Guidance Functional Subsystem Software Requirements (FSSR) document [v]. For details of the computations performed during the tasks, refer to the FSSR.

**3.1.3.2.2. PEG Initialization**

The purpose of the guidance initialization subtask is to assign initial values to parameters used in the other PEG functional blocks. Most of these parameters such as TGO, KPHASE, etc., are independent of the PEG mode. Others, such as target position constraint switches, SALT and SPLANE, and desired cutoff vectors, RD and IY, are dependent upon the particular guidance mode. The following paragraphs specify the initialization subtask requirements for both mode-independent parameters and mode-dependent parameters:

**3.1.3.2.2.1. Mode Independent**

The following parameters are required to be initialized as indicated for all guidance modes:

PHI = 0	OMEGA = 0	SINIT = OFF
TPRIME = TGD	B = EARTH_MU/RMAG <sup>3</sup>	TPREV = 0
TGO = 1	RGRAV = -0.5 B RGD	OTREQ = OFF

**3.1.3.2.2.2. Linear Terminal Velocity Constraint Mode**

The guidance logic for the LTVCON mode does not require the burnout orbit plane to be constrained. The unit normal to the desired orbital plane is obtained as follows: If the plane constraint is earth-fixed (EF\_PLANE\_SW = ON) then: IY\_DES = EARTH\_FIXED\_TO\_M50\_COORD(T\_GMTLO) \* IYD else, rotate IYD to adjust for nodal regression IY\_DES = M\_NODE\_ADJ \* IYD

Furthermore, position constraint calculations are bypassed by setting the flags SPLANE and SALT to OFF.

A desired turning rate for the maneuver is computed as follows:

THETA\_DOT = SQRT(B)  
WMAG = KLAMDZX THETA\_DOT

This mode also requires an initial estimate of VGO. Therefore, the following calculations are performed to initialize the VGO vector for this mode:

1. Initialize the predicted cutoff conditions and VGO as for the standard ascent mode:

RP = RGD, VP = VGD, VGO = 0

2. Perform the following subtasks for the LTVCON mode:

- a. Desired orbit plane correction subtask
- b. Desired position subtask for the LTVCON mode
- c. Desired velocity subtask for the LTVCON mode

The initial value of the change in accumulated sensed velocity is set to zero.

DVS = 0

#### 3.1.3.2.3. *PEG Functional Flow*

**Error! Reference source not found.** is adapted from the Shuttle FSSR. They outline the functional flow of the algorithm inside PEG. VGo is the velocity to be gained. TGo is the Time to go. Any further detail outlining the contents of the various boxes can be found in the FSSR.

Deleted: Figure 3.1.3-1

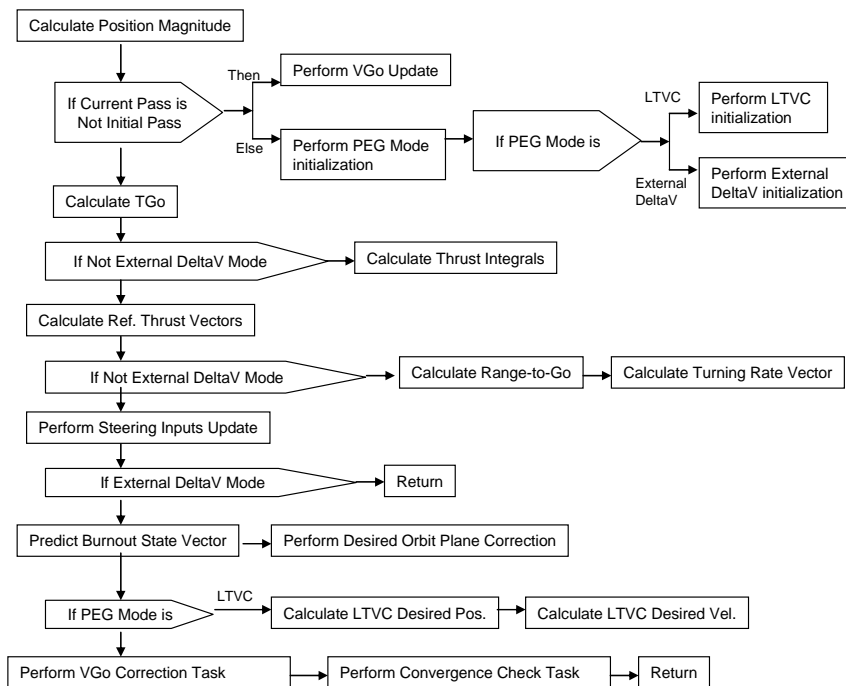

Figure 3.1.3-3 PEG Task Functional Flow

Deleted: 5

### 3.1.3.3. Powered Guidance Application to Abort Modes

#### 3.1.3.3.1. UAS

UAS does not employ an OME burn and therefore does not require a powered guidance algorithm.

#### 3.1.3.3.2. TAL

**Error! Reference source not found,** shows an example TAL trajectory flyout using BIG. As can be seen, the BIG flyout from the call to guidance at 581 seconds (blue line) closely matches the truth vehicle flyout (green line) until the atmosphere begins to affect the trajectory. The ability to match closely the altitude profile was one of the primary reasons for selecting BIG as the guidance algorithm since abort performance is constrained by aerothermal limits on the vehicle.

Deleted: Figure 3.1.3-8

**Error! Reference source not found,** shows the commanded LVIY pitch and yaw attitudes during the burn. Since the TAL burn is performed inplane, the yaw command is zero. The BIG flyout employs a constant pitch attitude during the burn. The pitch command is seen to decrease near the end of the burn slightly, as the shorter remaining burn arc requires a larger pitch delta to achieve the minimum altitude. The droop altitude constraint is released when current mass is within 292 kg (20 slugs) of the desired shutdown mass. Iterating on pitch close to the shutdown mass is undesirable, as large changes in pitch attitude are required to affect relatively small changes in final altitude.

Deleted: Figure 3.1.3-9

Some small excursions in the commanded pitch attitude can be seen near the beginning of the burn. These are the result of roll jet firings, which are picked up in the sensed acceleration, which is then used during the flyouts at these times. The additional acceleration results in a lower pitch attitude being required for that flyout, which also results in a change to the pitch command from guidance. Once the roll attitude settles out, these transients go away. The sensed acceleration transients will also be filtered by navigation in the final flight software.

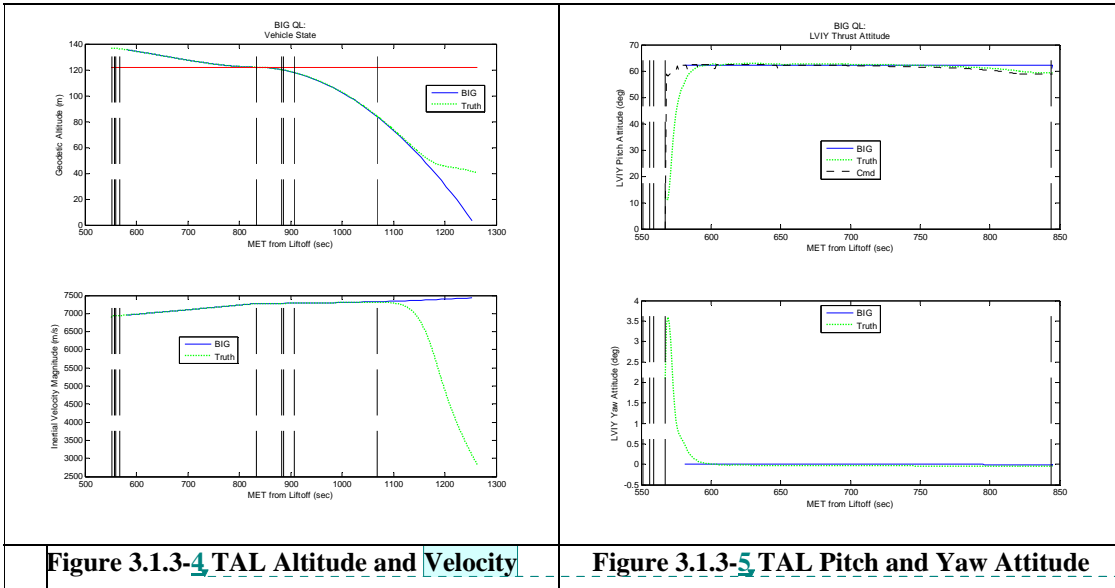

Figure 3.1.3-4 TAL Altitude and Velocity

Figure 3.1.3-5 TAL Pitch and Yaw Attitude

Comment [RP4]: consider deleting from here down.  
 Deleted: 8  
 Deleted: 9

### 3.1.3.3.3. RTAL

RTAL employs an open loop pitch command, so the pitch iteration logic described for TAL is bypassed. RTAL does adjust the shutdown time to achieve a desired range from the landing site. This logic is the same as the TAL shutdown. The range gain is specific to the mode and landing site. This process is discussed further in the targeting section below.

**Error! Reference source not found,** shows the BIG flyout compared to the truth geodetic altitude and inertial velocity magnitude during the burn (561 – 606 sec MET). Again, the trajectories match quite well. The flyout is logged starting at 580 seconds, which is approximately the time the vehicle achieves the commanded pitch attitude. As can be seen, this burn is shut down when the range target is achieved rather than reaching the minimum altitude constraint, 121.9 km (400 kft). A last RTAL boundary case would shutdown either at the minimum altitude or when the minimum time of freefall constraint has been reached. Earlier logged flyouts will not match quite as well since the BIG flyout assumes the capability to achieve the desired burn attitude instantaneously. This is particularly visible in **Figure 3.1.3-7Error! Reference source not found,** which shows the thrust direction in the LVYIY frame. The large pitch slew at the beginning of the burn can be seen as the truth vehicle

Deleted: ¶  
 Figure 3.1.3-11

Deleted: Figure 3.1.3-7

converges on the retrograde burn attitude. There is also a small yaw transient during this maneuver.

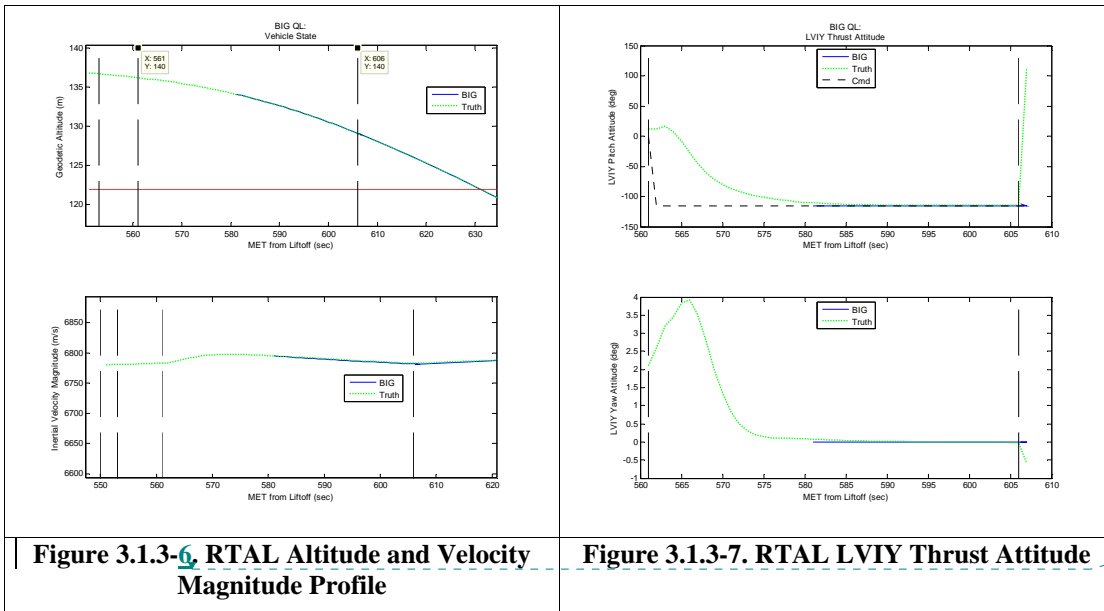

Figure 3.1.3-6. RTAL Altitude and Velocity Magnitude Profile

Figure 3.1.3-7. RTAL LVIIY Thrust Attitude

Deleted: 11

### 3.1.3.3.4. ATO

ATO guidance employs a multi phase pitch control BIG flyout of both the burn and the coast to apogee. The droop phase is designed to maintain a minimum altitude, similar to the TAL pitch iteration. This phase is followed by a pitch limit phase, which matches the vertical component of the thrust acceleration with the local gravitational and centripetal acceleration to avoid a second droop. The final burn phase iterates on pitch and burn duration to achieve a desired apogee altitude at a desired time. At the end of the burn, BIG propagates to apogee to provide partials for the next burn iteration. Velocity and flight path targets are adjusted to satisfy apogee conditions based on fixed partials. This works well because flight path has a larger impact to apogee altitude than time for all targets. There is logic to interpolate to apogee time ( $v_x=0$ ).

Since ATO targets conditions similar to the abort achievability flyout, a limited version of the logic shown in **Error! Reference source not found.**, is employed to determine the desired pitch command. ATO trajectories require 2 burns to achieve a stable orbit. The first burn is performed by BIG, and achieves nominal insertion conditions similar to the intended CLV targets. The second burn employs PEG insertion targeting. This burn employs the same guidance as that employed by the nominal insertion burn and is the same general algorithm that is employed for deorbit guidance.

Deleted: Figure 3.1.4-2

### 3.1.3.4. Entry Guidance

For SM aborts, entry guidance is employed once the SM has been jettisoned. Through untargeted and targeted guidance algorithms, the CM will be controlled until splashdown.

#### 3.1.3.4.1. *Untargeted Entry*

An untargeted entry is characterized by flying a constant bank angle until the drogues are about to deploy. The constant bank angle is provided based on restrictions such as the DAEZ and HSIR. This type of entry may be used by any SM abort in case of failure; however, this type of guidance is used for UAS and RTAL aborts.

The bank angle that was chosen for UAS and RTAL aborts at the DAEZ boundary was  $-90^\circ$ . As the bank angle increases, the lift-vector rotates towards a downward position. As the lift-vector rotates downwards, the amount of G-loads experienced by the crew increases until HSIR violations start to become more common. Based on previous analysis, the  $-90^\circ$  bank angle was selected as it provided the highest crossrange entry, which reduces the downrange traveled by the CM. Additionally, this bank angle provided no HSIR violations based on Monte Carlos analyses performed to support this document; however, this value will be reinvestigated in the future.

#### 3.1.3.4.2. *Targeted Entry*

A targeted entry is characterized by controlling the lift-vector to follow an entry reference trajectory until the drogue chutes are about to deploy. This type of guidance uses a Modified Apollo Final Phase algorithm, which is very similar to the Final-phase guidance employed by PredGuid. The reference profile selected is dependent on restrictions such as energy state, DAEZ, and HSIR. This type of guidance will eventually be used by all abort modes; however, due to resource limitations and a benefit analysis, this type of guidance is only being used by TAL and AOA aborts for the Preliminary Design Review cycle. The details of the Modified Apollo Final Phase algorithm and applicable requirements are described in more detail in Volume 5.

### 3.1.4. Abort Achievability Determination

The GN&C Subsystem has the responsibility to determine what abort modes are currently achievable during any point along the ascent trajectory. The currently achievable abort modes can be determined based on on-board knowledge the current vehicle configuration and state. This determination will be made by the GN&C subsystem throughout ascent and a list of the currently achievable abort modes will be provided to the Orion Abort Decision Logic (ADL) as shown in [Error! Reference source not found.](#)

Deleted: Figure 3.1.4-1

The ADL has the capability to automatically initiate an abort based on abort conditions detected within the Ares I launch vehicle or the Orion vehicle. The initiation of an abort also includes the selection of the type of abort mode to execute (LAS, UAS, TAL, etc.). During the selection of the abort mode the ADL must have knowledge about which of the abort modes can be safely achieved given the current vehicle state. As mentioned above, this list of currently achievable abort modes is provided by the GN&C Subsystem. It is the responsibility of the ADL to prioritize the achievable abort modes, in the event that there are multiple achievable abort modes, and select the highest priority abort mode. This prioritization is based on the likelihood



of safely returning the crew to earth and any input from the crew or Mission Systems. The decision to abort and the type of abort mode is selected is then communicated to the GN&C Subsystem via the Timeline Management (TM) software by changing the Mission Phase and Mission Segment to an abort mode. Once the decision to abort and the type of abort mode is selected. There is also an interface from the crew and ground controllers (Mission Systems and Ground Systems) to allow human input into the abort triggering and abort mode selection process. Further ADL and TM details are beyond the scope of this paper. The next section will describe the GN&C determination of safely achievable abort modes.

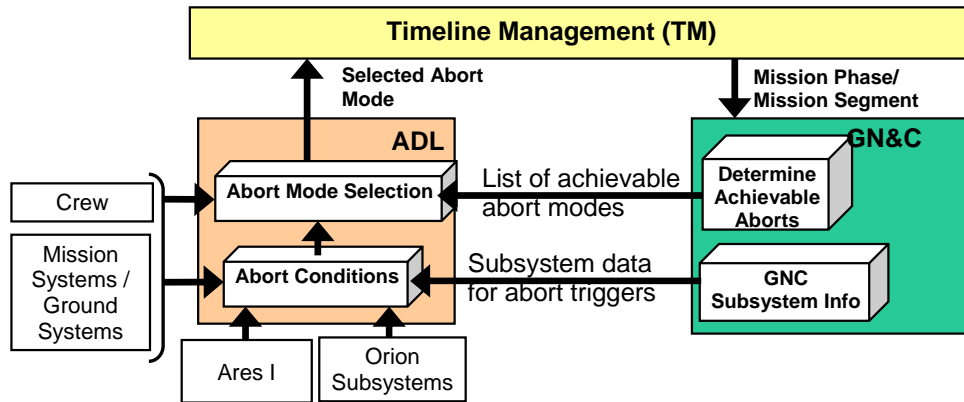

Figure 3.1.4-1. ADL and GN&C Interaction

For LAS aborts, there is only 1 available mode (although the GN&C sequencing will vary based on initial conditions). A LAS abort is achievable as long as the LAS is still attached. Determining achievability is therefore a relatively trivial task. For SM aborts, there are 3 different modes with minimal overlap so a method of determining which modes are currently achievable is required.

Since continuous abort coverage is one of the driving requirements for SM Aborts, the ability to accurately determine the currently achievable abort modes is essential. During the PDR design cycle, an onboard real-time abort prediction capability was developed to improve the ability to meet this requirement. This algorithm re-uses functionality already resident in BIG to simulate an abort trajectory from the vehicle's current state and determine achievability. The primary difference between the predictor and guidance mode of BIG is that multiple phases are required prior to initiating the SM burn. The sections below describe how the phases of BIG are used to determine if each of the SM aborts (UAS, TAL, RTAL, and ATO) are achievable.

Comment [j5]: Spelled out above?

### 3.1.4.1. Boost Phase

This phase models the launch vehicle trajectory from the current state to nominal Main Engine Cut-Off (MECO) using the current vehicle sensed acceleration. Using sensed acceleration allows the predictor to account for off-nominal upper stage engine performance. Linear tangent steering (from ATO guidance) is employed to achieve the MECO targets. Testing of this algorithm by comparing with actual CLV trajectory has shown very good correlation. Flying the nominal trajectory prior to the abort provides the capability to determine the abort boundaries before they occur. Error! Reference source not found. shows the Boost Phase

Comment [j6]: Is the policy to use Ares I or CLV to refer to the launch vehicle.

Deleted: Figure 3.1.4-2

Iteration logic. The yaw iteration is performed simultaneously with pitch, and the yaw position and velocity targets are zero in the LVIIY frame.

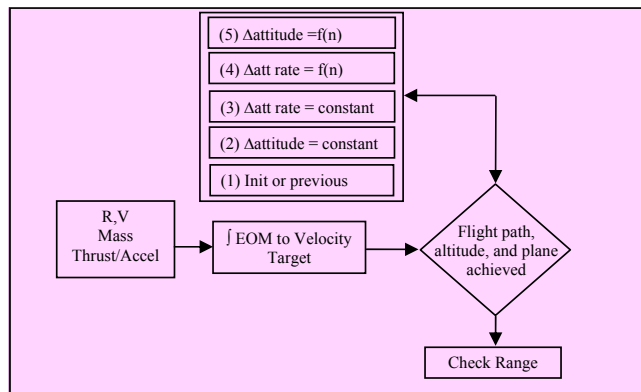

Comment [J7]: What does 1-5 mean?

**Figure 3.1.4-2 Boost Phase Iteration Logic**

### 3.1.4.2. Abort Initiation Phase

This phase models the upper stage engine shutdown, CLV tailoff, and CEV / CLV separation. This sequencing follows the nominal separation sequence once an SM abort is triggered. The average CLV tailoff impulse modeled as an equivalent full CLV thrust duration. During the separation phase the vehicle mass is reduced to the post-separation mass (CEV-only mass). The expected thrust of the Auxiliary thrusters is applied to perform the separation maneuver used to.

### 3.1.4.3. Guidance Phase

The guidance phase essentially follows the same logic as guidance would employ for the SM abort mode being modeled. For example, when performing a TAL, the guidance phase attempts to pitch up to maintain the minimum altitude while heading toward the desired landing zone. After burnout, the OME shuts down and the vehicle state is integrated to the Instantaneous Impact Point (IIP). A separate IIP range target is employed for the predictor as the vehicle needs only to avoid the DAEZ rather than reaching the “nominal” abort landing site.

One difference between the guidance and predictor modes is the modeling of the maneuver to burn attitude. The OME TVC system is used to achieve the desired burn attitude for Mode 3 and 4 SM aborts. These maneuvers can involve fairly large slew angles. In guidance mode, there is no penalty associated with commanding the desired attitude instantaneously. In the predictor mode, the performance loss associated with the slew maneuver is significant and must be included. Therefore, these maneuvers are rate limited to roughly account for the control system response to the step function guidance commands.

### 3.1.4.4. Prediction Phase

Once the simulation and modeling of the flyout is complete, the IIP range target miss distance, or distance between the prediction IIP and the target IIP, is computed. If the results of

the flyout do not satisfy the success criteria, i.e. does not indicate an achievable abort, or if they exceed the success criteria beyond a tolerance then iteration occurs allowing convergence on the boundary of the abort capability. While the guidance mode iterates on desired burn duration up to the maximum allowable burn duration. If the guidance iteration loop does not converge on a solution the predictor mode also iterates on CLV engine out time. The IIP range miss is converted to a CLV engine out time adjustment via the predictor range gain. The engine out time is iterated upon to find the time at which each SM abort mode is achievable.

Comment [J8]: List success criteria

### 3.1.4.5. Prediction Performance

**Error! Reference source not found,** shows the predicted final range from each call to the predictor modeling a TAL abort. The first call to the predictor for the TAL boundary is performed at 429 seconds MET. By 453 seconds, the predictor has determined the proper engine out time to achieve the success criteria (an Engine Out (EO) time of approximately 549 seconds, shown in Figure 3.1.4-4). This figure also demonstrates the difference between the guidance IIP range target and the predictor IIP range target. The predictor needs to determine the first time the DAEZ and minimum altitude constraints can be achieved so a shorter range target is used. Guidance, however, is targeted to provide margin for achieving the nominal TAL landing zone so a larger range target is set. **Error! Reference source not found,** shows the predicted TAL boundary. As can be seen, the boundary remains fairly steady once the predicted range is achieved and accurately predicts the true vehicle performance well in advance of the abort boundary. This result was checked by actually initiating an abort at the predicted boundary time verifying that a TAL abort executed at that time can be successfully executed. The calculation of these abort mode boundaries are used to determine the achievable list of abort modes communicated to the ADL used for abort mode selection.

Deleted: Figure 3.1.4-3

Deleted: Figure 3.1.4-4

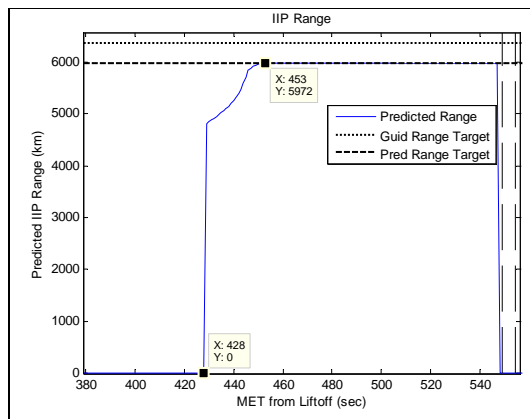

Figure 3.1.4-3 BIG Predictor Range

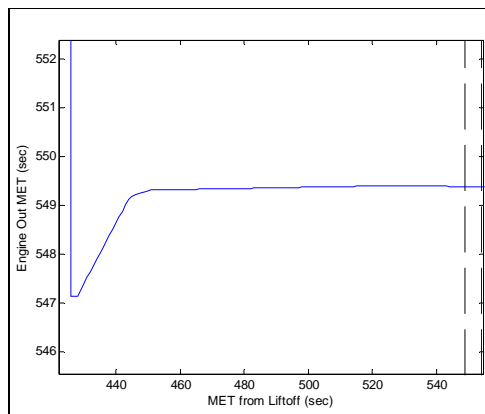

Figure 3.1.4-4 BIG Predictor Engine Out MET

### **3.1.5. Navigation System Overview**

#### **3.1.5.1. Nav Hardware Overview**

The navigation design architecture is structured to meet the key driving requirements of an autonomous measurement system providing real time updates of vehicle navigation state through all mission phases including ascent and SM aborts. In addition to providing high rate navigation Position, Velocity, Attitude, and Time (PVAT) state solutions, the design provides high rate low latency linear and angular data for vehicle control and guidance for a safe abort trajectory and landing targeting. The design guidelines also maintain flexibility in mission data parameters including programmable filter coefficients, real time parameter handling and updates. Crew and ground over-rides for FDIR processing, navigation state selections, and activity list sequencing is included in the flexible nature of the design. Hard coded define parameters are highly minimized, as are the number and complexity of different modes of operation in flight software to increase external user flexibility and reduce complexity.

The following principal design points were evaluated for the SM Abort Navigation PDR design: (1) altitude estimate during main engine burns, (2) altitude and velocity errors at the time of drogue chute deployment, (3) time of free-fall prediction sensitivities to navigation errors, and (4) the effect of navigation uncertainties on the overall landing footprint.

As discussed within the Guidance section, the vehicle must maintain a specified altitude during the main engine burn. If the estimated vehicle altitude falls below the specified limit, the main engine is turned off. Large uncertainties in the vehicle's altitude could result in increased heating (if the true altitude is lower than the estimated altitude), or an early termination of the main engine burn (if the altitude estimate is lower than the true altitude).

Altitude and velocity uncertainties at the time of drogue and main chute deployment could potentially lead to a deployment outside of the design limits for the chutes. The two primary options are a velocity trigger for drogues with a timer for main chute deploy and an altitude trigger for both chutes. PDR analysis will determine which method is appropriate for SM aborts and identify any design impacts, such as requiring that GPS becomes available after LAS jettison.

Uncertainties in the estimate of vertical velocity and altitude could lead to an incorrect calculation of the time of free-fall to 91 km (300 kft). An accurate free-fall time calculation is needed to insure that all activities can be completed after the main engine burn during an RTAL abort, including the re-orientation of the CM to heatshield forward attitude, prior to entry. Additionally, the time of freefall constraint is being considered as an abort trigger and as such navigation uncertainties must be understood to ensure no false positive abort indications.

Lastly, the integrated effect of navigation uncertainties (i.e. guidance terminating a burn early due to position and velocity errors, controls not achieving the desired thrust direction, or an incorrect abort mode being selected due to navigation error) will lead to dispersed footprints at landing (all other conditions being equal). This landing footprint causes a loss in overlap performance since the dispersed footprint must be considered when evaluating the GN&C requirements to 95% success. At the time this paper was written, the sensitivities to Navigation uncertainties were still being investigated.

### **3.1.5.2. Nav Concept of Operations**

#### **3.1.5.2.1. *Pre-Launch***

In the months before launch, Mission Operations personnel follow a standard template for mission design, crew and ground procedure development, and Orion VMC parameter updates. A reference mission profile is assembled for the planned launch date, including all planned maneuvers and activities. All parameter and software updates for GN&C and other systems are compiled into the mission-specific software build. This build includes all mission parameters necessary to enable the intended level of automated GN&C functions for absolute navigation, rendezvous, proximity operations, and docking. This software load is then tested by various simulation facilities, including integrated simulations with crew and flight controllers. Lessons learned from prior missions are incorporated into the mission design as needed, as are new mission requirements. Mission Operations also develops and validates crew and flight controller procedures for all nominal and contingency scenarios. Crew procedures may be prompted from an electronic procedure interface on the Orion display unit, or from a paper version. Flight controller procedures will include the ability to command and modify the execution of various automated and scripted vehicle actions.

On the day of launch, flight controllers determine the phantom plane for Ares I guidance. A pre-launch alignment will be commanded to start the platform ground alignment process followed by a transition to suborbital navigation mode.

#### **3.1.5.2.2. *Ascent Phase: Launch Through Abort Initiation***

Starting at launch, IMU data is incorporated into the Orion absolute navigation state vector. The Orion GPS receiver is active from pre-launch through ascent, but does not track GPS satellites and process GPS measurements until after LAS jettison when the removal of the boost protective cover permits reception of GPS signals. For nominal mission ascent, only IMU data is incorporated into the Orion absolute navigation state during powered flight. At the start of an SM abort initiation, the navigation state performance will be determined by the IMU only navigation state. After LAS separation, GPS data is expected to be available within 90 seconds and will provide an option to use an aided navigation state after abort initiation. This is common for ATO, UAS, RTAL, or TAL SM abort scenarios.

The Ares I launch vehicle GN&C system will be in control of the vehicle stack during powered ascent, but the Orion navigation system is required to provide data for crew/ground monitoring and the Abort Decision Logic (ADL) software. In the event of an abort, this data will be used by Orion guidance, controls and the Landing and Recovery System (LRS) to ensure safe landing for the crew. For nominal ascent and the majority of an abort trajectory, the Orion navigation system will rely extensively on the IMU's for inertial only vehicle state propagation. GPS aiding is not available until LAS separation and is not needed for LAS aborts until after main chute deployment for roll orientation. Some SM aborts may require GPS to ensure safe drogue chute deployment.

To ensure readiness for a Pad Abort, the navigation system must perform an on-pad alignment to initialize vehicle attitude and velocity prior to the crew boarding the vehicle. This

alignment process entails a coarse alignment where earth rate and gravity sensed by the IMU are used to compute an initial attitude estimate. This attitude estimate is refined through a 40 minute fine align Kalman Filter algorithm which also estimates sensor biases and velocity. The vehicle position is initialized from site survey data of the launch pad. Additional site survey data to determine the difference between local level and geodetic level may also be utilized if needed. After the 40 minutes of fine alignment are complete the navigation system may transition to an inertial navigation mode when commanded or when a pad abort is initiated. For nominal operations, the navigation system will be transitioned to inertial navigation 30 seconds prior to launch. The IMU's will be commanded into the high-g mode for pre-launch alignment, ascent and ascent aborts.

After lift-off, the navigation system will propagate vehicle position, velocity, attitude and attitude rate using a J2 gravity model, IMU sensed change in velocity ( $\Delta V$ ), and change in attitude ( $\Delta \theta$ ). A vehicle state will be computed for each IMU. Additionally FDIR logic will be used to select a non-faulted IMU and its vehicle state for use outside of navigation. The IMU body rates and accelerations will be available at 40 Hz and a separate 2<sup>nd</sup> order filter is available for each output channel. It is expected that these filters will be set per mission phase and additional filtering being implemented in the VMC's if needed. Vehicle attitude will be computed in the VMC's and will also be available at 40 Hz for vehicle control. Vehicle position and velocity will be available at 1 Hz with higher rates being possible if required. The vehicle state data will be transformed from the J2000 inertial frame to an earth-fixed frame for ground track display (latitude & longitude) and altitude for crew and ground monitoring. Geodetic altitude will be computed using a WGS-84 datum. It is expected that body rates and accelerations will also be sent to the crew and ADL to aid in the abort determination. A comparison of Orion and Ares-1 vehicle state and rate data will also be provided to the crew and ADL.

SM aborts do not have to face the severe environments of a LAS abort, but they must contend with the growing error in the inertial only navigation state. This error is in part due to the initial attitude error that came from azimuth and tilt attitude errors in the on-pad alignment process. These errors, in general, grow linearly with the down range distance. Another substantial part of the error is due to the well-known instability in the altitude of inertial only navigation. This error grows geometrically in time and can reach ten's of kilometers by the time of an SM abort. GPS is available for SM aborts and can be used to correct these errors but there is a desire to keep the system simple and not have to rely on GPS. The use of GPS will also improve inertial only navigation as IMU and attitude errors become observable and can be estimated. There is an option to provide both the inertial only and GPS aided state to the crew or ground for a manual switch-over since there is a reasonable amount of time for a decision.

SM aborts must also contend with the quantization noise on the IMU acceleration outputs. This noise, which can cause oscillations in the steering commands, is expected to be in the 0.5 m/sec<sup>2</sup> level for the high g IMU setting. Options for mitigating this noise include low pass filtering, use of an integrated "average acceleration" and/or switching the IMU's to the low-g setting. The first two options induce lag into the signal, but they are fully viable options that are currently used by numerous launch vehicles. The last option can lower the noise level by a factor of 20 or more, but may induce a transient into the IMU accelerometer outputs. These options will be fully investigated in the CDR time frame.

For some SM aborts, such as an ATO, there exists an option to switch to an on-orbit navigation mode which includes GPS and star tracker measurement updates, a low-g accelerometer setting in the IMU's and higher fidelity propagation options (e.g., higher order gravity and integration options, atmospheric drag models, etc). The focus of the on-orbit navigation is ensuring an accurate solution over extended time periods (hours to days). The decision to transition to the on-orbit mode can be left to Mission Operations personnel in the future.

### 3.1.5.3. Nav Performance

An assessment was completed within Osiris for an RTAL abort which compares the landing footprint caused by Navigation uncertainties for different design cases. The largest red footprint, shown in [Figure 3.1.5-1](#) below, is the CM landing footprint caused from Navigation errors only, as propagated on a MIMU-only design. The next largest yellow ellipse is a Navigation solution in which GPS is acquired after blackout (e.g. after entry). Although GPS may be desired at this point for reasons of airbag inflation or roll orientation at splashdown, acquisition of GPS after blackout does not provide any real benefit with regards to the size of the landing footprint. The green ellipse is a result of acquiring GPS immediately after the abort was declared and the type of abort (RTAL / TAL) was determined. Although this is not necessarily a plausible scenario, it shows the difference in footprint sizes as a result of large (IMU-only) navigation errors during the SM powered portion of flight. The magenta ellipse shows the resulting landing footprint if GPS were available at the time of abort declaration through landing (with the exception of the black-out region). As evident in the figure below, the GPS-aided solution provides for a much more accurate landing footprint. However, future work will finalize the requirements for Navigation accuracies at various epics which will likely show that sufficient overlap between RTAL and TAL exists to allow for a large Navigation footprint.

Deleted: Figure 3.1.5-1

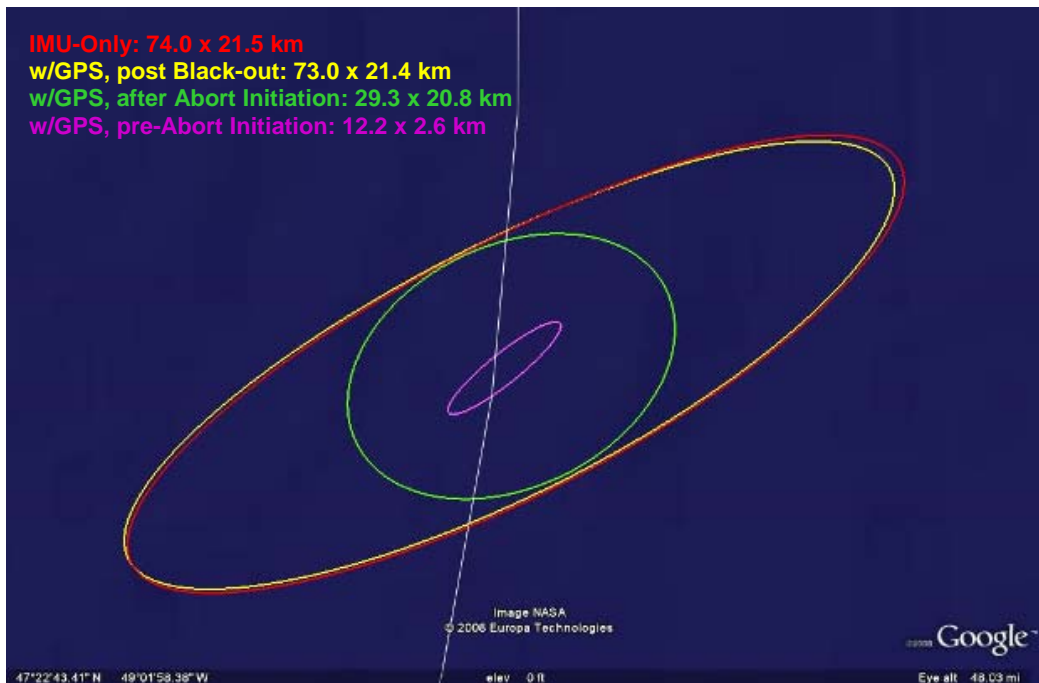

**Figure 3.1.5-1 IMU vs. GPS Navigation Performance Comparison**

### 3.1.6. Control System Design

List applicable requirements and design guidelines used. Include such things as autonomy requirements, accuracy requirements, fault-tolerance requirements, and target gain and phase margins used in designing the control system.

#### 3.1.6.1. Operational Envelope

List operational envelopes for which the control laws were designed for. Include limits for dynamic pressure, body rates, attitude limits, load limits, etc.

#### 3.1.6.2. SM Abort Control Architecture

The SM effectors are commanded by the SM flight control system described by the block diagram shown below in [Figure 3.1.6-1](#). The control system may be configured into several different control modes, as described later within this section.

Deleted: Figure 3.1.6-1



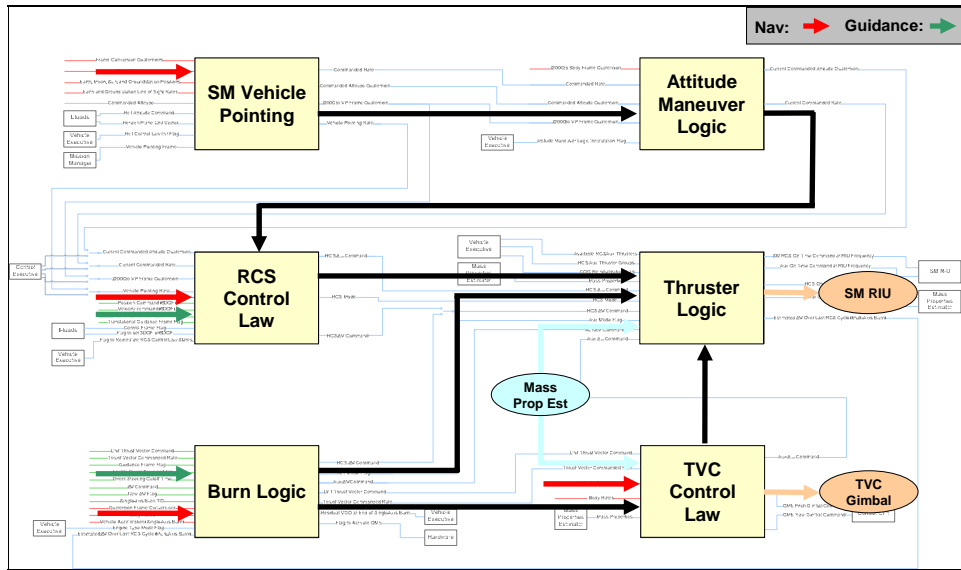

**Figure 3.1.6-1 SM Abort Flight Control Architecture**

### 3.1.6.3. SM Flight Control Algorithm High-Level Description

The Orbit Mode Team (OMT) owns the individual SM Control Algorithms and is therefore responsible for documenting each algorithm's design. Please refer to Volume 3 of T-078 for a description of each algorithm. This section will provide a high-level overview of each control algorithm or CSU utilized by SM Aborts.

#### 3.1.6.3.1. Burn Logic

For Service Module Aborts, Burn Logic operates in two different manners: (1) external  $\Delta V$  and (2) steered mode. During the CLV / CEV separation activity, the external  $\Delta V$  mode is employed. Burn Logic receives a  $\Delta V$  command in a defined frame and outputs steering commands in the body frame to the TVC control law. Burn Logic also decrements the  $V_{go}$  calculator until the desired  $\Delta V$  is completed. The calculated  $V_{go}$  is also sent to the Thruster Logic for precision cut-off of the Auxiliary thrusters. When operating in a steered mode, the Burn Logic accepts a unit thrust vector in a defined frame as well as a cut-off time and outputs a unit thrust vector in the body frame to the TVC control law. For detailed information regarding the Burn Logic algorithm, see the on-orbit and transit section of T-078, Volume 3.

#### 3.1.6.3.2. TVC Control Law

The TVC Control Law is responsible for converting the unit thrust vector sent from Burn Logic into two possible outputs: (1) pitch / yaw gimbal commands for the OME TVC and (2) pitch / yaw angular rates for Aux steering to the Thruster Logic. The control law implements a state-space based linear control law, which minimizes the thruster vector error through a rate loop, similar to the TVC control law implemented on the Space Shuttle. For detailed

information about the TVC Control Law algorithm, refer to the on-orbit and transit section of T-078, Volume 3.

#### **3.1.6.3.3. RCS Control Law**

The RCS control law is responsible for calculating the  $\Delta V$  and  $\Delta\omega$  commands to be sent to the Thruster Logic based on the commanded position, velocity, attitude, and attitude rate, and the current vehicle state. It is a hybrid controller consisting of both phase-plane and linear control components. For detailed information about the RCS Control Law algorithm, please see the on-orbit and transit section of T-078, Volume 3.

#### **3.1.6.3.4. Thruster Logic**

Thruster Logic is responsible for converting the RCS and Auxiliary thruster  $\Delta\omega$  and  $\Delta V$  commands into thruster on-time commands. It utilizes a candidate optimal group (COG) jet selection formulation, which minimizes propellant use to achieve the desired command subject to thruster minimum on-time, minimum off-time, and duty cycle constraints. The RCS and Auxiliary jet selections have been formulated to be independent of one another. RCS jet selection may be completed in a 6-DOF mode ( $\Delta\omega$  and  $\Delta V$ ), 3-DOF mode ( $\Delta w$ ) or a roll control mode, which utilizes 3-DOF selection with zero pitch and yaw commands. Auxiliary jet selection may be completed in a 2-DOF off-pulse mode, which maximizes translational thrust, or a 2-DOF on-pulse mode. Thruster Logic enables the formulation of pseudo-thrusters (grouping of thrusters) in order to deliver additional control authority within the confines of the COG formulation. For detailed information about the Thruster Logic algorithm, refer to the on-orbit and transit section of T-078, Volume 3.

#### **3.1.6.3.5. SM Vehicle Pointing**

SM Vehicle Pointing serves several purposes during on-orbit operation. For SM aborts, it is responsible for generating the commanded attitude quaternion sent to Attitude Maneuver Logic given the desired attitude. The desired attitude can be a 3-DOF attitude, such as that provided during the attitude maneuver and hold mode, or a desired roll orientation. For detailed information about the SM Vehicle Pointing algorithm, please refer to the on-orbit and transit section of T-078, Volume 3.

#### **3.1.6.3.6. SM Attitude Maneuver Logic**

The SM Attitude Maneuver Logic is responsible for calculating an attitude and attitude rate command for the RCS control law given a desired attitude and rate command from SM Vehicle Pointing. This command is completed by calculating an Eigen axis about which to rotate and the Eigen angle of rotation needed to achieve the slew from the current state to the desired state. The Eigen angle is incremented per control cycle based on an Eigen angle acceleration parameter and a maximum Eigen angle rate parameter. The open-loop commanding improves performance during large, fast slews required during Service Module aborts. For detailed information about the SM Attitude Maneuver Logic algorithm, please refer to the on-orbit and transit section of T-078, Volume 3.

### 3.2. Integrated SM Abort Performance

The most difficult overlap region to cover in order to maintain continuous abort coverage capability is the time in the trajectory in which an RTAL and TAL abort may be necessary for an ISS mission. As can be seen in [Table 3.1.6-1](#), insufficient coverage exists between a UAS and TAL abort for ISS missions as the dispersed overlap boundary

Deleted: Table 3.1.6-1

**Table 3.1.6-1 ISS UAS / TAL Overlap, TD5-G**

UAS / TAL Overlap: ISS Open L/F July (TD5-G)						
Nominal Boundary	IIP (km)	MET (sec)	IIP (km)	MET (sec)		
	3647.2	518.92	3725.5	520.72		
	UAS Losses		TAL Losses		Total Losses	
	IIP (km)	Time (sec)	IIP (km)	Time (sec)	IIP (km)	Time (sec)
CEV	8.0	0.15	17.1	0.31	25.12	0.46
CLV	9.2	0.17	14.1	0.24	23.32	0.41
Environment	21.2	0.41	20.6	0.40	41.80	0.81
Navigation	43.2	1.02	7.0	0.40	50.20	1.42
Entry	4.2	0.09	0.5	0.01	4.70	0.09
Nominal Overlap					-78.30	-1.80
Total Dispersion Loss	50.1	1.14	35.0	0.79	85.13	1.93
Dispersed Overlap (Margin)					-163.43	-3.73

[Table 3.1.6-2](#) below shows the overlap performance between ISS RTAL and TAL aborts for the TD5-G (light-fast July open) trajectory. Between these two types of aborts, 5.8 seconds of coverage overlap exists. Retrograde TAL aborts require firing the OME on the vehicle following a reorientation to point the thrust-vector downrange. This maneuver is complicated by the requirement to have separated the CM and achieved a heat-shield forward attitude before hitting the dense atmosphere. These issues add complexity and risk to the viability of the RTAL maneuver, which the team would prefer to avoid. However, given the fact that RTAL has been shown to be capable of successfully eliminating the gap in abort coverage between UAS and TAL, it is a necessary contingency.

Deleted: Table 3.1.6-2

**Table 3.1.6-2 ISS RTAL / TAL Overlap, TD5-G**

RTAL / TAL Overlap: ISS Open L/F July (TD5-G)						
Nominal Boundary	IIP (km)	MET (sec)	IIP (km)	MET (sec)		
	4135.2	528.20	3725.5	520.72		
	RTAL Losses		TAL Losses		Total Losses	
	IIP (km)	Time (sec)	IIP (km)	Time (sec)	IIP (km)	Time (sec)
CEV	13.5	0.24	17.1	0.31	30.62	0.54
CLV	15.2	0.27	14.1	0.24	29.32	0.50
Environment	30.7	0.46	20.6	0.40	51.30	0.86
Navigation	43.2	0.62	7.0	0.40	50.20	1.02
Entry	5.0	0.10	0.5	0.01	5.50	0.10
Nominal Overlap					409.70	7.47
Total Dispersion Loss	57.2	0.86	35.0	0.79	92.20	1.64
Dispersed Overlap (Margin)					317.50	5.83

## 4. CONCLUSIONS

During the ascent flight phase of NASA's Constellation Program, the Ares launch vehicle propels the Orion crew vehicle to an agreed to insertion target. If a failure occurs at any point in time during ascent then a system must be in place to abort the mission and return the crew to a safe landing with a high probability of success. To achieve continuous abort coverage one of two sets of effectors is used. Either the Launch Abort System (LAS), consisting of the Attitude Control Motor (ACM) and the Abort Motor (AM), or the Service Module (SM), consisting of SM Orion Main Engine (OME), Auxiliary (Aux) Jets, and Reaction Control System (RCS) jets, is used. The LAS effectors are used for aborts from liftoff through the first 30 seconds of second stage flight. The SM effectors are used from that point through Main Engine Cutoff (MECO). There are two distinct sets of Guidance and Control (G&C) algorithms that were designed to maximize the performance of these abort effectors. This paper has outlined the necessary inputs to the G&C subsystem, the preliminary design of the G&C algorithms, the ability of the algorithms to predict what abort modes are achievable, and the resulting success of the abort system. Abort success for the Preliminary Design Review (PDR) abort performance metrics and overall performance was reported.

The LAS abort results summary shows that there are some regions of interest where additional performance will be sought. The goal is to improve the probability of success of an abort that occurs at any time during the nominal ascent to be at least 95% effective. The SM abort results summary is encouraging. At all points in time from the beginning of the SM abort window until Main Engine Cutoff (MECO), there is a greater than 95% probability of successful recovery of the crew from a CLV systems failure, early shutdown, TVC fail-in-place, and TVC fail-to-null state. No abort gaps have been identified, but there are some missions where the amount of overlap is marginal. Between PDR and Critical Design Review (CDR) design refinement will occur to maximize this overlap. CLV TVC hard-over failures will be examined in more depth. Additionally, post-abort CEV failures (like chute, RCS strings, Aux string, OME, etc. failures) will be investigated.

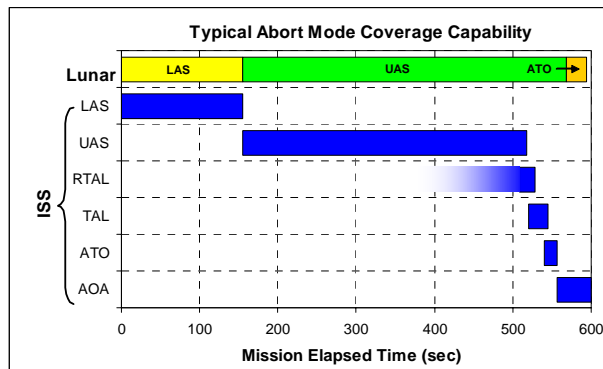

Figure 3.1.6-1. Sample abort mode overlap chart for an ISS mission.

## **5. ACKNOWLEDGMENTS**

---

The authors would like to thank the members of the Ascent Abort GN&C MODE Team who performed the majority of the analysis runs used to validate the G&C abort designs. In addition, the authors would like to thank the entire G&C algorithm design team for creating these preliminary designs. In particular, the LAS Abort Working Group co-lead David Raney and the SM Abort Working Group co-lead David Shoemaker contributed significantly to the success of this paper.

## 6. REFERENCES

---

- i. CAP Aerodynamics Team, "Orion Aerodynamic Databook," Version 0.41, CXP-72167, March 2008
- ii. Document 6029309002A0\_A.pdf, Orbital Sciences Corporation, 10 October 2007
- iii. ACM IDR\_P143-07\_Book\_1, Nov. 27, 2007
- iv. FltDyn-CEV-08-161, "Service Module and Docking Mechanism Jettison Attitude at PDR", NASA, October 2008
- v. Space Shuttle Orbiter Operational Level C Function Subsystem Software Requirements Guidance, Navigation, and Control, Part A, Guidance Ascent/RTLS, NASA, May 2003