Developments for Electroformed Nickel X-Ray Optics

*B Ramsey¹, D Engelhaupt², M Gubarev¹, S O'Dell¹, C
Speegle³, M Weisskopf¹*

¹NASA/MSFC

²University of Alabama in Huntsville

³Raytheon IS

Mandrel Preparation

1. CNC machine mandrel from Al bar

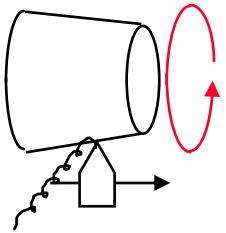

2. Clean, activate surface and plate with electroless nickel

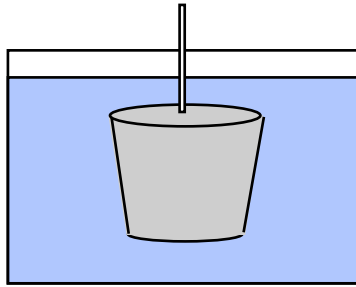

3. Precision grind or diamond turn, to sub-micron figure accuracy

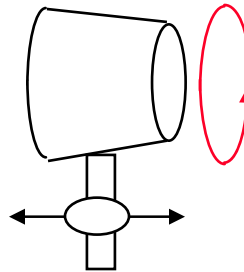

4. Polish to 3 - 4Å rms finish

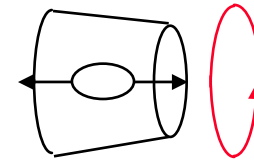

5. Confirm figure and surface with metrology

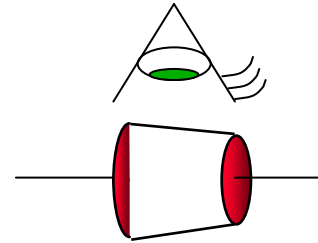

Shell Fabrication

6. Ultrasonically clean and passivate mandrel

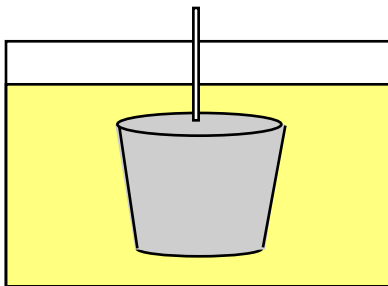

7. Electroform Ni/Co shell onto mandrel

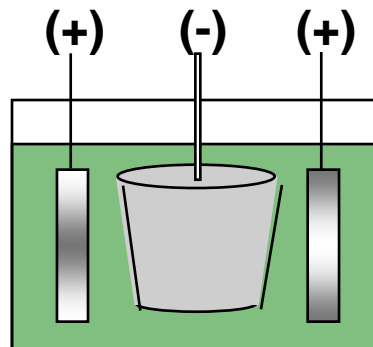

8. Separate Optic from mandrel in cold water bath

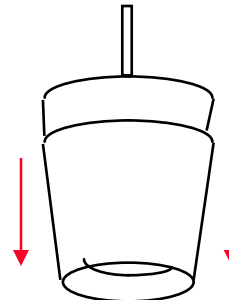

MSFC Infrastructure



ENR mirror shells at MSFC



Down to 50 μ m thick



Up to 0.5 m diameter

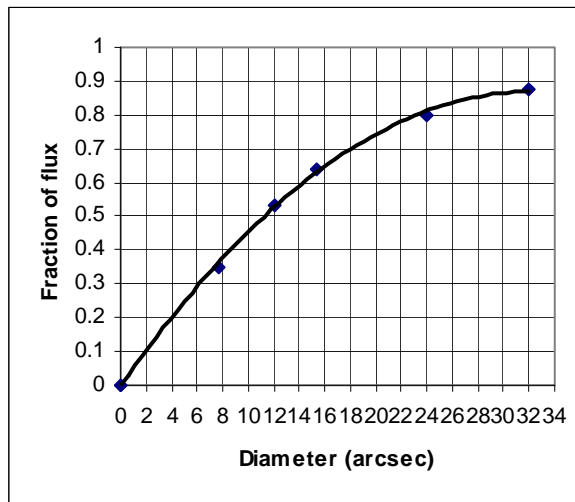
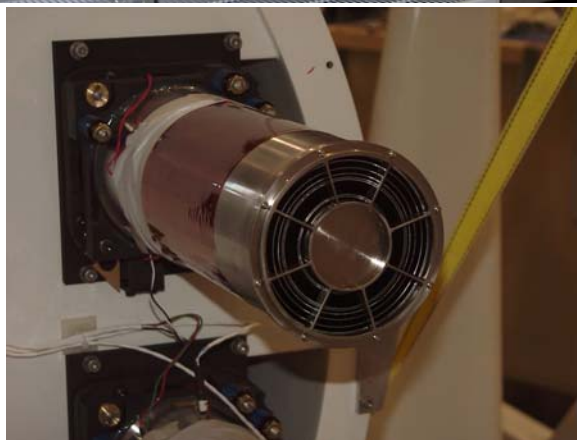

To 11 arcsec resolution



Down to 0.025 m diameter

Hard X-Ray Optics

For mandrels, shells and modules fabricated to date, we have:

- Typical mandrel = 8-10 arcsec HPD (prediction based on metrology)
 - Mostly conic approximations as mandrel not limiting factor
- Electroforming process = 6.5 - 10 arcsec HPD (to be added as RSS to the native mandrel figure)
 - Depends on electroforming bath configuration
- Resulting shells = 11 arcsec HPD (best), 15 arcsec HPD (typical) measured in x rays.
- Typical mirror module assemblies = 25-30 arcsec HPD

Hard X-Ray Optics .. Statistics

HERO

- 15 mandrels fabricated, 5 to 10 cm diameter, typically 8-10 arcsec HPD (conical approximation)
 - ~ 150 shells fabricated from these (250 micron thick) ... typically < 15 HPD shells
 - Simple assembly gives 25 arcsec modules

CON-X

- 4 mandrels fabricated, 15 cm to 23 cm diameter, < 10 arcsec HPD (conical approximation)
 - 35 shells, all 100 μm thick ... typically 15 arcsec HPD, best 13 arcsec.
 - Mounted shells tested at 30 arcsec HPD, limited by mounting process

FOXSI (Solar rocket program with Berkeley)

- Program just started, 7 mandrels required, 7-11 cm diameter, Wolter-1
 - Target module HPD = 15 arcsec.

Hard X-Ray Optics .. Improvements

Improvements in x-ray optics depend on better-quality mandrels and better alignment processes - we are working on both these areas :

- We are investigating an electrochemical process for rapid mandrel figuring which can remove mid-spatial-frequency errors imparted by earlier steps in the fabrication process.
- We are developing a new mounting and alignment system, specifically designed for thin-shell optics

Electrochemically-Enhanced Mechanical Polishing (EEMP)

- With conventional mechanical polishing mid-spatial frequency errors are hard to remove and dominate performance
- An automated, deterministic figuring method is highly desirable

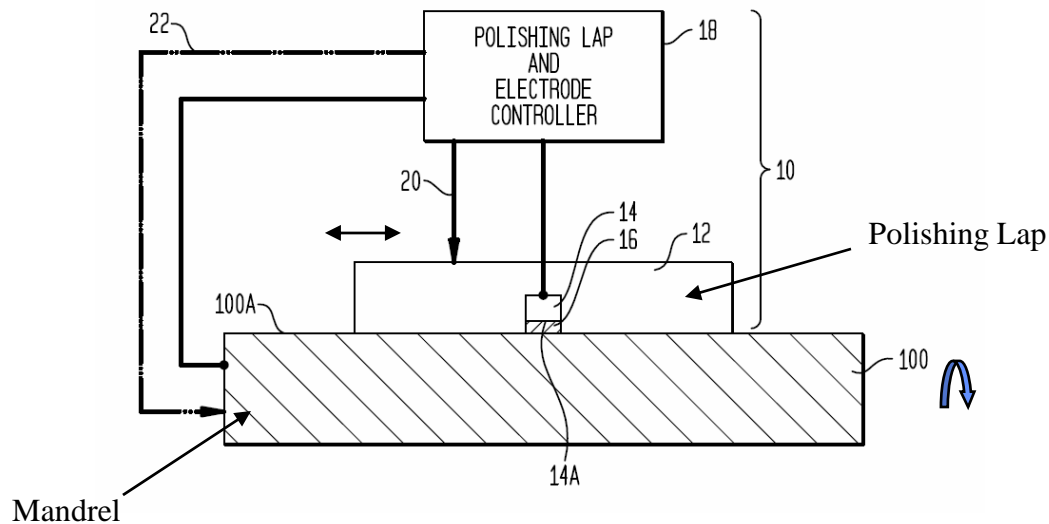

- An electric current can be used to remove material from a conductor in the presence of an electrolyte
- Combining this with mechanical polishing provides a means of figuring and polishing

Electrochemically-Enhanced Mechanical Polishing (EEMP)



EEMP test system: A computer-controlled polishing arm contains electrodes which apply a computer-controlled current to the substrate being figured and polished.

Electrochemically-Enhanced Mechanical Polishing (EEMP)

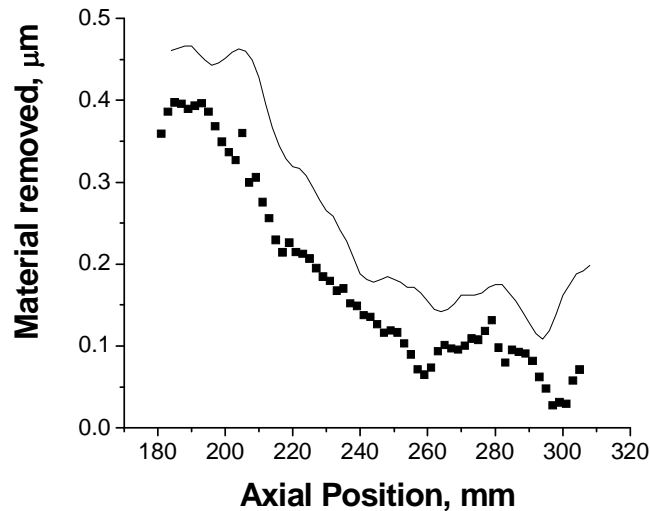

Material removal rate depends on applied current .. figure above shows current (solid line) and material removed (squares) along length of a mandrel

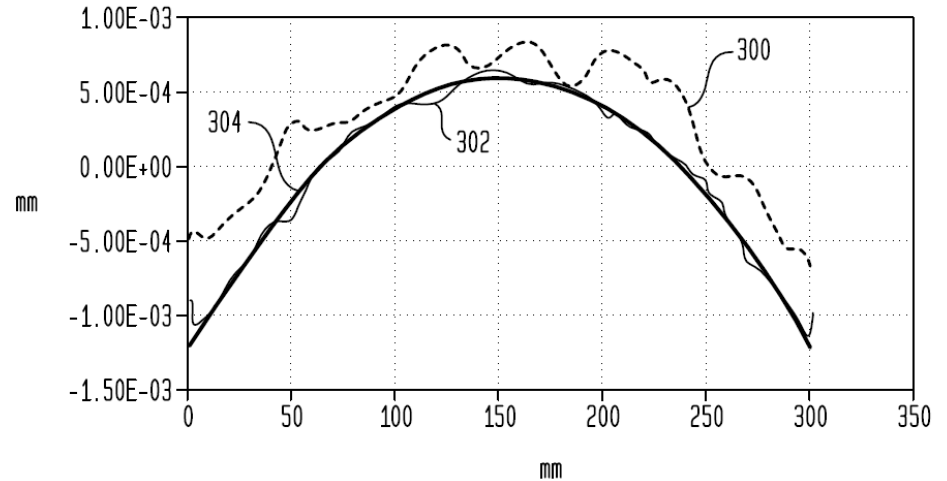

Dashed line shows mandrel figure profile after mechanical polishing (300). Thin solid line shows mandrel figure after applied EEMP (302). Desired shape is solid line (304).

Alignment / Mounting System for Full-Shell Replicated X-Ray Optics

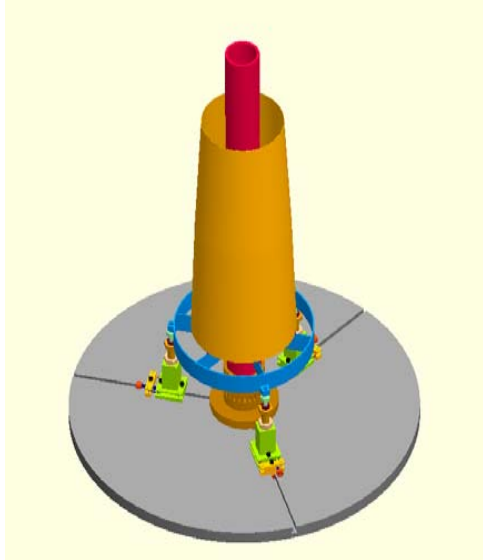

Shell supported on actuators.

Circularity measured via non-contact sensors.

Spider mounted on adjustable pillars

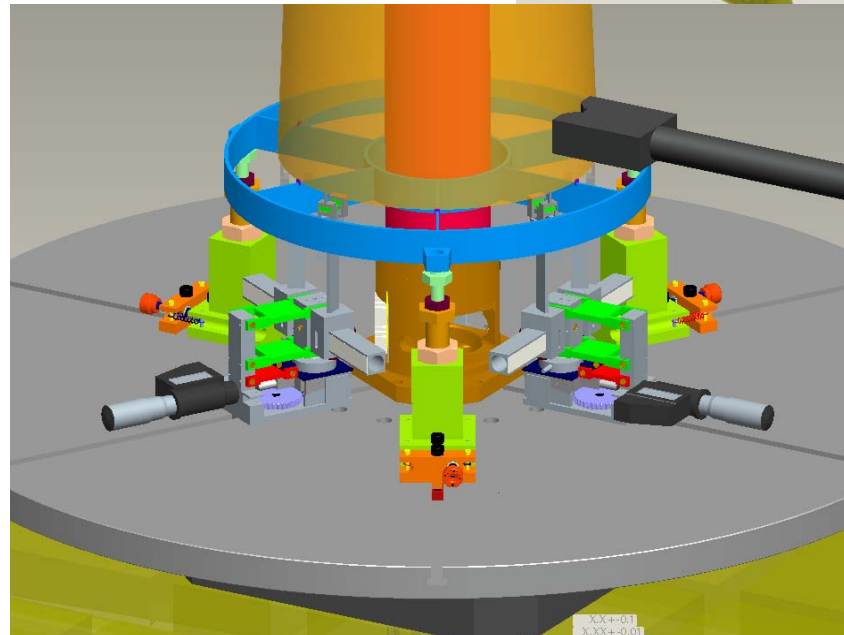
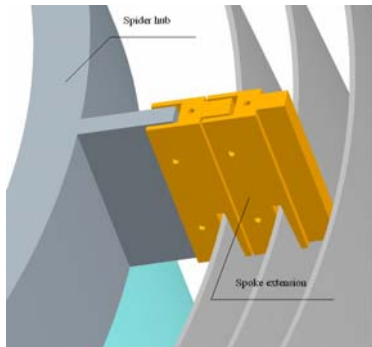
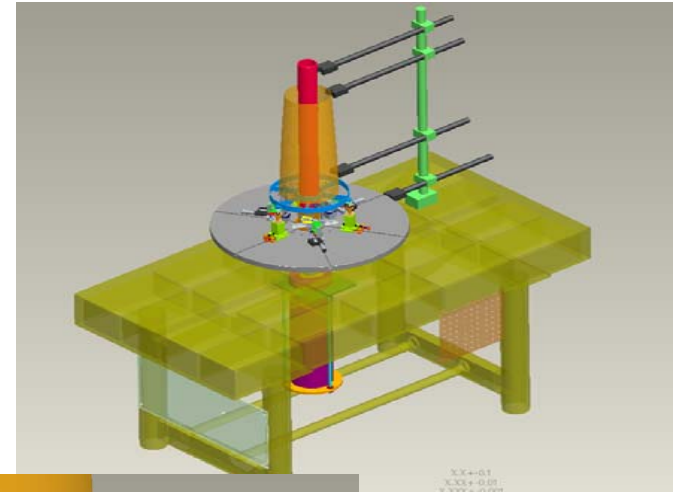

Alignment / Mounting System for Full-Shell Replicated X-Ray Optics

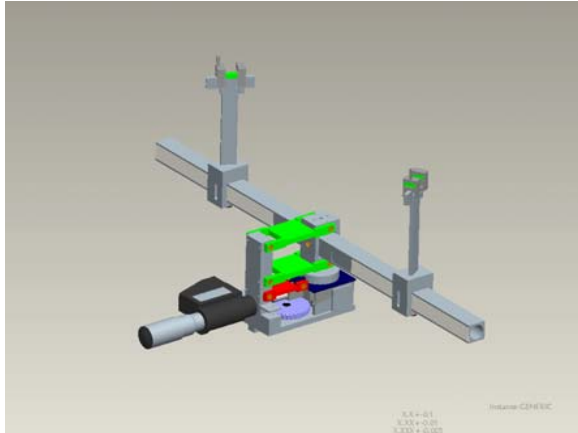

Shell support system



Assembling the shell supporting stage.



The non-contact displacement sensors are Keyence laser triangulation probes with a resolution of 10 nm and accuracy better than 60 nm.

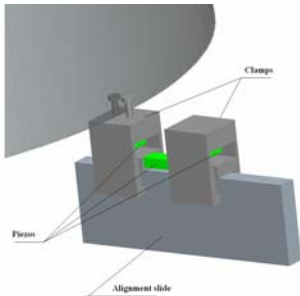

Inch worm actuators for shell adjustment

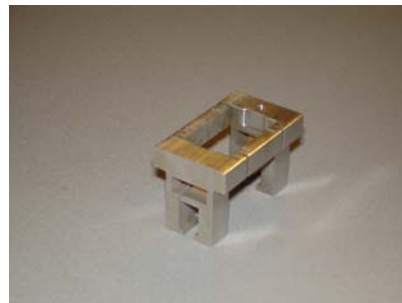

Alignment / Mounting System for Full-Shell Replicated X-Ray Optics

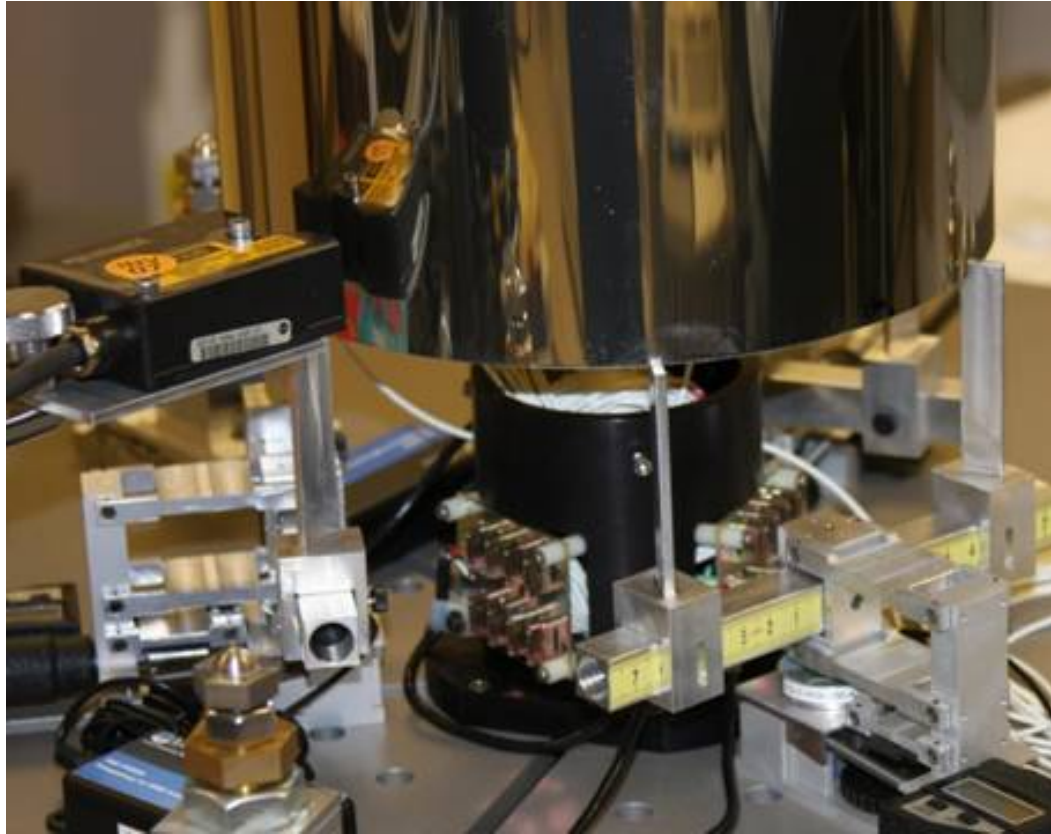

Test shell mounted in the alignment system

Selective Deposition

A final stage of improvement involves small figure corrections after the mirror shell has been electroformed. This is accomplished through selective deposition, where small amounts of material are coated on the inside of the shell to 'fill in' figure imperfections:

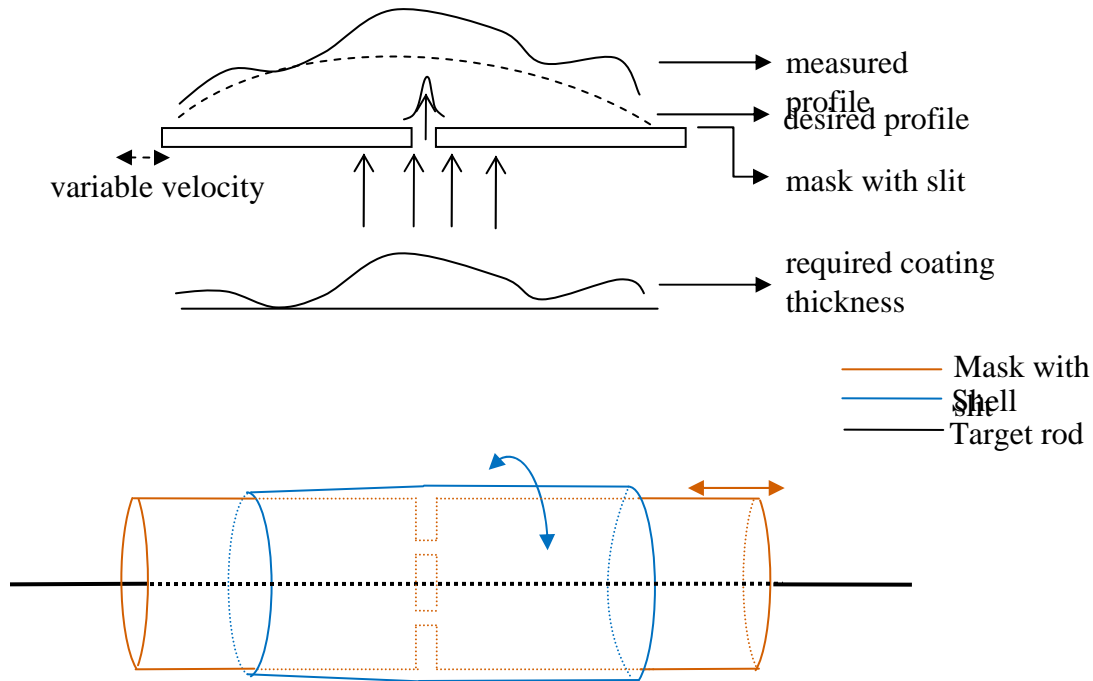

Selective Deposition

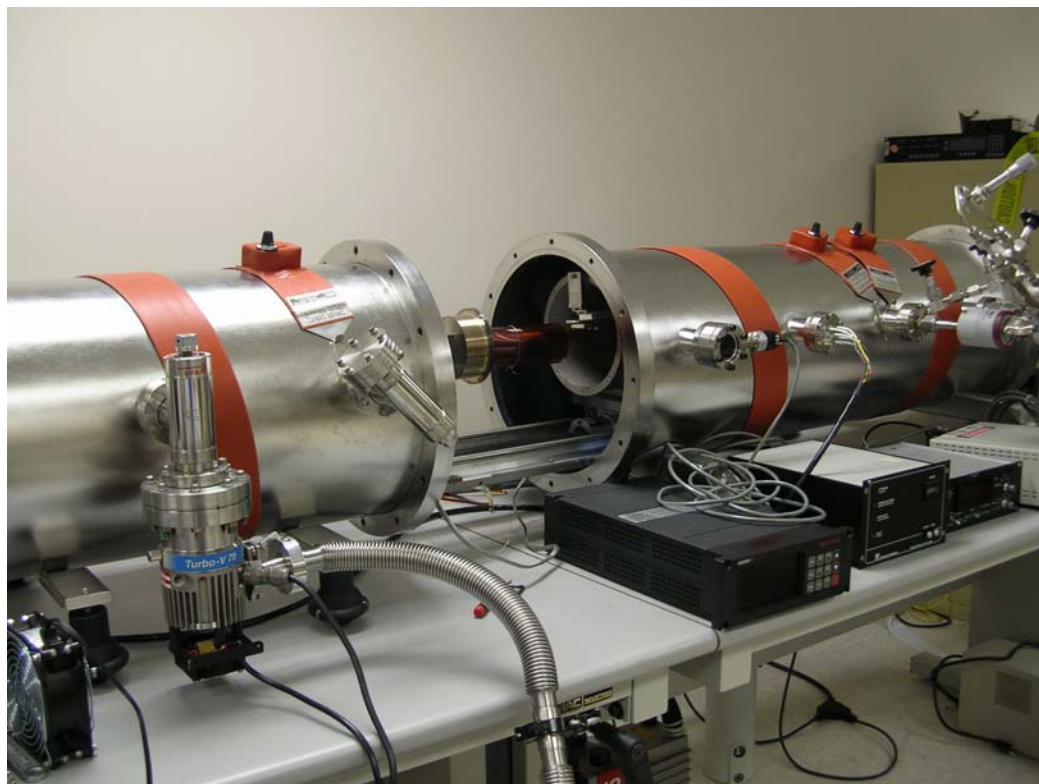

RF sputtering chamber used for selective deposition studies



Typical coating mask

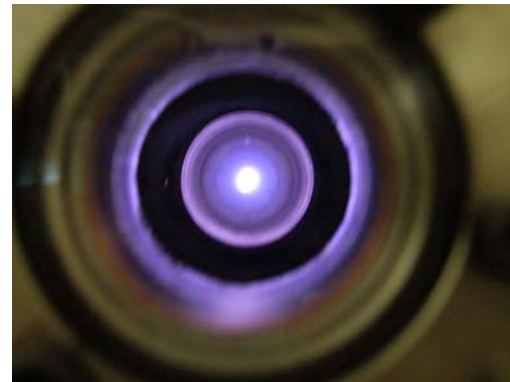

RF plasma visible during coating

Selective Deposition

Figures at right show interior mirror profiles before and after correction by selective deposition.

Three runs were modeled, with mask widths of 5mm, 3mm and 1mm. Total coating time was 30 hrs.

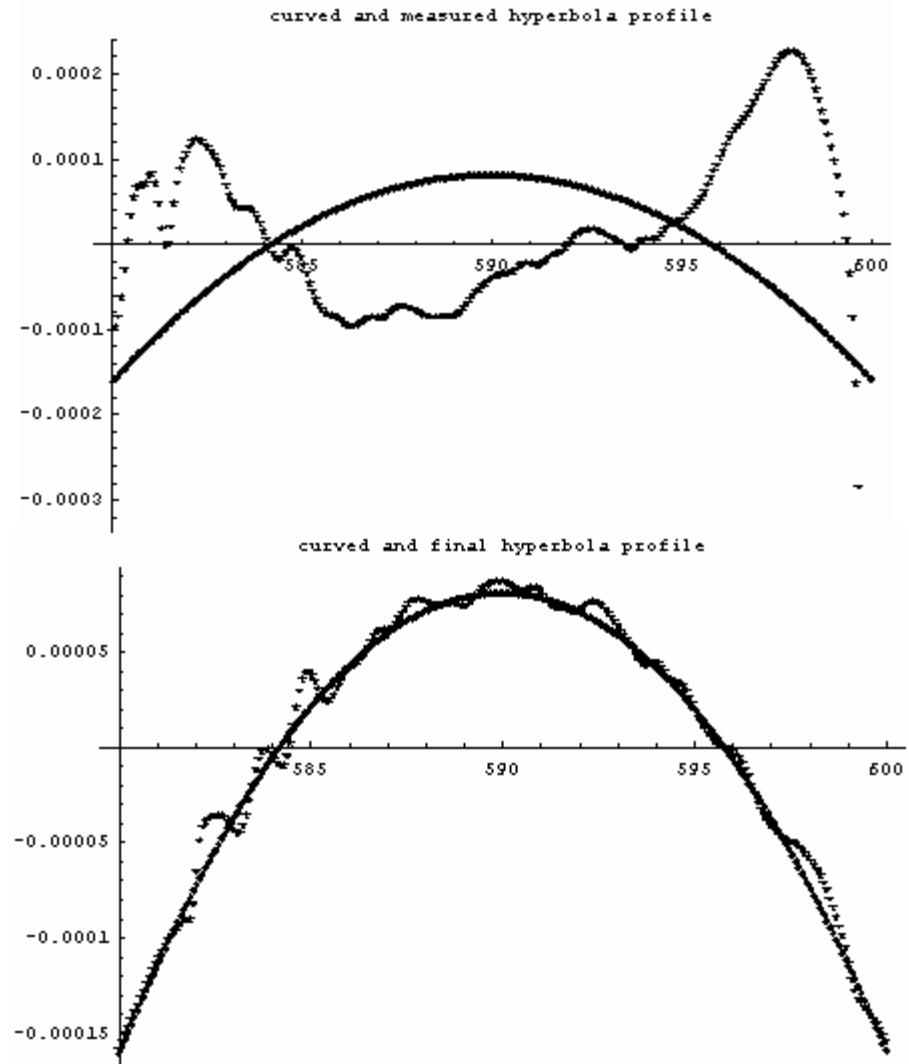

Conclusion

- Axial figure errors currently limit the imaging properties of replicated x-ray optics.
 - Contributors to these errors include the initial quality of the x-ray mandrels and figure distortions imparted during mounting of the subsequently replicated shells.
 - We have presented developments aimed at improving mandrel quality and the shell mounting process. In addition, a technique for post figuring, selective deposition, is under study.