

# Double Helical Gear Performance Results in High Speed Gear Trains

Dr. Robert F. Handschuh  
Aerospace Engineer  
Army Research Laboratory, Vehicle Technology Directorate  
NASA Glenn Research Center  
Cleveland, Ohio 44135  
[Robert.F.Handschuh@nasa.gov](mailto:Robert.F.Handschuh@nasa.gov)

Ryan Ehinger, Eric Sinusas, & Charles Kilmain  
Bell Helicopter Textron Inc.  
Fort Worth, Texas 76101

## ABSTRACT

The operation of high speed gearing systems in the transmissions of tiltrotor aircraft has an effect on overall propulsion system efficiency. Recent work has focused on many aspects of high-speed helical gear trains as would be used in tiltrotor aircraft such as operational characteristics, comparison of analytical predictions to experimental data and the affect of superfinishing on transmission performance. Baseline tests of an aerospace quality system have been conducted in the NASA Glenn High-Speed Helical Gear Train Test Facility and have been described in earlier studies. These earlier tests had utilized single helical gears. The results that will be described in this study are those attained using double helical gears. This type of gear mesh can be configured in this facility to either pump the air-oil environment from the center gap between the meshing gears to the outside of tooth ends or in the reverse direction. Tests were conducted with both inward and outward air-oil pumping directions. Results are compared to the earlier baseline results of single helical gears.

## INTRODUCTION

High speed, heavily loaded and lightweight gearing components are found in propulsion systems for rotorcraft. The high pitch line velocity that is part of these systems makes the thermal aspects of the gear system design very important. Transmission systems using helical gear trains in tiltrotor aircraft provide the proper spacing between the parallel engine and rotor shafts as shown in Figure 1 (Ref. 1). These gear trains can induce additional thermal problems as the idler gears in this system receive two meshing cycles (on opposites sides of the gear teeth) per revolution. Therefore, weight optimized aerospace drive system components can have difficulty when it is required to operate with a primary lubrication system failure.

In past studies using this gear train system, testing has focused on basic operational characteristics (Refs. 2 and 3), comparison of analytical predictions to experimental results (Ref. 4), and the affect of superfinishing (Ref. 5). The results from these studies have shown and quantified the effect of operational conditions on the power to rotate the gear system at high speed and load.

In prior testing the individual thermal/energy loss mechanisms were separated into gear meshing, bearing, and windage losses. The gear meshing and bearing losses are fairly well understood (Ref. 6) and some design modifications to the gears and bearings can provide some benefit to increase performance. The gear windage losses, however, are the least understood, but can be a source of dramatic tiltrotor performance improvement once this mechanism is better understood.

In the work to be described in this paper, a double helical gear train was tested. The test facility has gears that are bolted to the shafting (in practice this interface is avoided to remove fasteners and shafting complexity). This permitted the gearing to be mounted from either side of the gear inner flange and thereby the system could be tested two ways. One way was to have the gears pump the air-lubricant environment (from lubricating and cooling jets) outward towards the axial ends of the teeth. The second way was to have the gear mesh pump the environment inward from the ends of the teeth towards the center gap. The double helical gears were also tested with and without shrouding as used in the prior studies. Temperature data from axial thermocouple rakes and tooth end arrays will also be provided. Finally, the double helical results will be directly compared to prior studies from the same facility (single helical gear results; (Refs. 2 to 7)).

## TEST FACILITY AND TEST HARDWARE

### Test Facility

The test facility used for this study is shown in Figure 2. The facility is a closed-loop, torque-regenerative testing system. There is a test gearbox and slave gearbox that are basically mirror images of each other. Each gearbox has an input gear, three idlers, and one bull gear. The gearboxes are joined together through the input gears and bull gears via shafting.

A 500 hp DC drive motor powers the facility and its output speed is increased using a 5.7:1 speed-increasing gearbox. The output of the speed-increasing gearbox then passes through a torque and speed sensor before connecting to the slave gearbox.

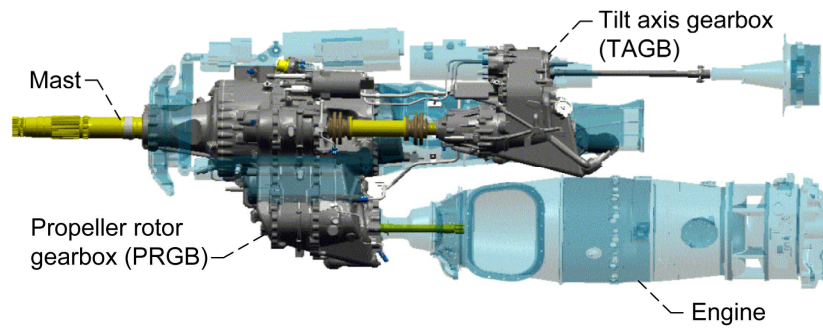

**Figure 1. Layout view of typical tiltrotor nacelle (airplane mode).**

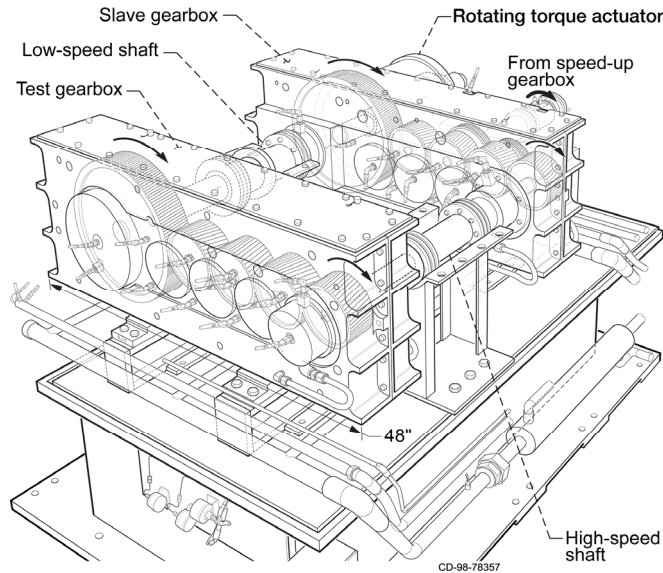

**Figure 2. NASA high-speed helical gear train test facility.**

Each gearbox has separate oil supply and scavenge pumps and reservoirs. All flow rates have been calibrated at various temperatures and pressures prior to installation for accurate flow rate measurements. Lubrication system flow rate is controlled using the supply pressure. Temperature is controlled via immersion heaters in the reservoir and heat exchangers that cool the lubricant returned from the gearboxes. Each lubrication system has very fine 3- $\mu\text{m}$  filtration. Nominal flow rate into the test or slave gearboxes at 80 psi is approximately 15 gpm.

The lubricant used in the tests to be described was a synthetic turbine engine lubricant (DoD-PRF-85734). This lubricant is used in gas turbine engines as well as the drive systems for rotorcraft.

### Test Hardware

The test hardware used in the tests to be described is aerospace quality hardware. The basic gear design information is contained in Table 1. The input and bull gear shafts typically have a combination of roller bearings with ball bearings to contain the resultant thrust loads, whereas the idler gears only have roller bearings. For the double helical gear tests, the two thrust bearings (input shaft and

bull gear shaft) needed in the single helical gear arrangement were removed. The double helical gear configuration does not produce an axial load from the gear forces; therefore the thrust bearings are not needed. A photograph of the double helical gears in the inward pumping gear arrangement without the shrouds is shown in Figure 3. A photograph of the shrouds from earlier tests is shown in Figure 4 (shrouding was configurable for either single or double helical gear trains).

**Table 1. Basic Gear Design Data for Double Helical Gear Train.**

Number of teeth input and 2nd idler	50
Number of teeth 1st and 3rd idler	51
Number of teeth bull gear	139
Axial face width each side, mm (in.)	39.6 (1.560)
Gap between tooth flank sides, mm (in.)	41.1 (0.555)
Normal plane module, mm (normal plane diametral pitch (1/in.))	0.254 (10)
Normal plane pressure angle, degree	20
Transverse plane module, mm	3.10 (8.192)
Helix angle, degree	35
Gear material	Pyrowear 53

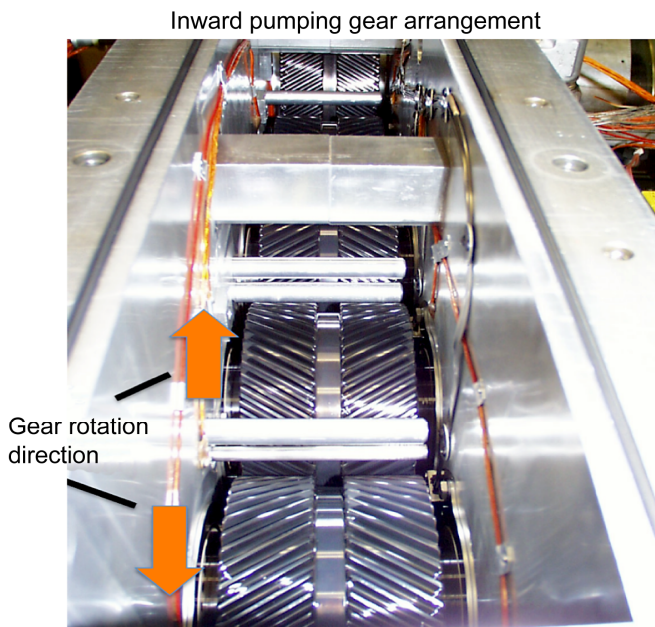

Figure 3. Photograph of test gearbox with shrouds removed.

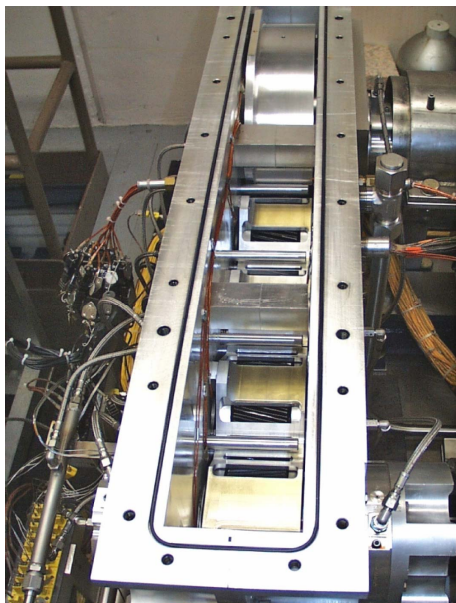

Figure 4. Shrouding used during testing.

## TEST INSTRUMENTATION AND DATA ACQUISITION

### Test Instrumentation

The instrumentation used in these tests was the same as in prior studies except for the axial fling-off temperature rakes. With the double helical gear mesh tests, another set of probes was fabricated so that the fling-off temperatures from the various axial locations of the gear could be measured. The probe is shown in Figure 5 along with the one from prior single helical testing. Also in these tests, axial arrays (9 thermocouples) were used at the mesh exit regions (Figure 6). The temperature probes were at locations in the gearbox as shown in Figure 7.

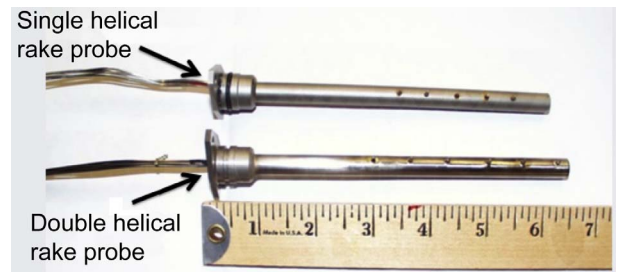

Figure 5. Comparison of rake probes for single and double helical gear train studies.

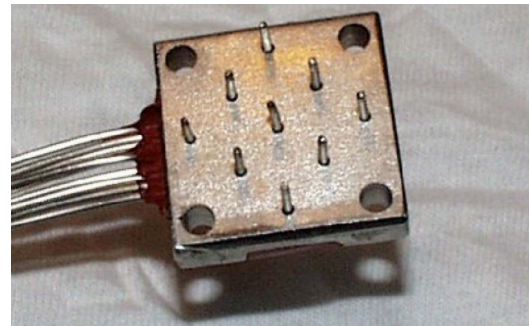

Figure 6. Array probe used at the tooth end—meshing position.

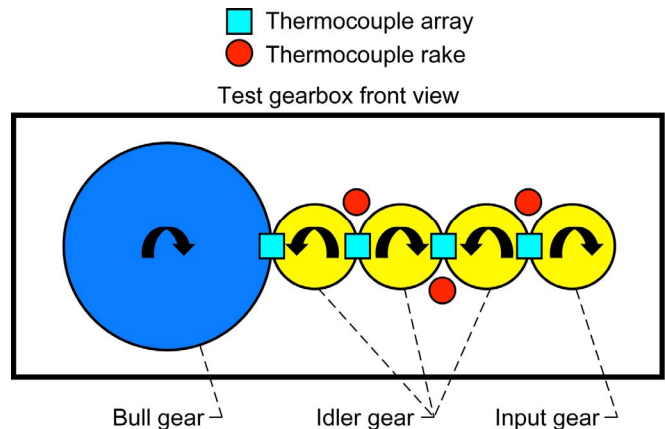

Figure 7. Locations of array and rake thermocouples within the test gearbox.

### Data Acquisition

The test facility data system monitors three important facility parameters during operation. Speed, torque (supplied torque and loop torque), and temperature measurements were made during all the testing conducted. The test system loop torque is measured on the shaft connecting the bull gears from the test and slave gearboxes. A telemetry system was utilized in this location to measure loop torque.

The data recording system used in this study has the capability of taking data from all parameters at a rate of one sample per second (tests in this study recorded data every 2 sec). The data is displayed to the test operator in real time. Data is stored in a spreadsheet format and each sensor can be viewed at any time during a test and when post processing the results.



The test procedure for collecting the data to be presented was the following. For a given set of conditions (speed, torque, lubricant pressure and lubricant oil inlet temperature) the facility was operated for at least 5 min or until the temperatures of interest had stabilized ( $\sim\pm 2$  °F).

### EXPERIMENTAL RESULTS

In this part of the paper, just the results attained with the double helical gears will be discussed. Comparison to the single helical gear tests will be discussed in the next section. The gears were operated at various speed, torque, lubricant flow rate and lubricant inlet temperature conditions. For all the results shown in this section, the lubricant inlet temperature for the test gearbox was held at 200 °F. Also, the slave gearbox conditions (lubricant temperature and flow rate) remained unchanged for all of the test conditions of the data to be presented. For the experimental results to be described in this paper the nomenclature shown in Table 2 will be used.

**Table 2. Figure Nomenclature**

OP	Outward Pumping
IP	Inward Pumping
S	Shrouds
NS	No Shrouds
SH	Single Helical
DH	Double Helical
ISF	Superfinished Gear Flanks
GRND	Ground Gear Flanks

The first comparison is made between temperatures across the gear face width and the direction of gears pumping of the air—lubricant mixture, as shown in Figure 8. Four different sets of data are shown in the figure for the 2nd and 3rd idler gear location. Thermocouple probes 1 and 6 were near the ends of the teeth and thermocouple probes 3 and 4 are near the center gap of the double helical gears. The outward pumping arrangement had the lowest temperature at the gap locations. The inward pumping configuration had an increase in temperature towards the tooth gap. Also, for the

inward pumping configuration, the inward pumping had a much higher temperature at the gap region when the shrouding was in place.

The next comparison to be made is shown in Figure 9. In this figure the maximum thermocouple rake and array temperatures are plotted for the two speed conditions (12500 and 15000 rpm input shaft speed), three bull gear shaft torque levels (33, 67, and 100 percent of maximum), outward or inward pumping configuration, and with or without shrouds. All data shown in Figure 9 was taken with the standard inlet conditions mentioned above. In the figure two bands of data are shown due to the two speed conditions. The rake or array maximum temperatures increased linearly with applied torque. At either input shaft speed (band), the inward pumping gear arrangement produced the highest (shrouded, rake probe) and lowest (shrouded or unshrouded, array probe) temperatures. For the inward pumping arrangement, a limited amount of lubricant from the meshing gears would be assumed to strike the array probe in comparison to that flung from the gear mesh radially and pumped axially towards the center of the face width of the gear.

The last comparison with respect to just the double helical gear tests is shown in Figure 10. In Figure 10(a) and (b) the standard conditions (200 °F lubricant inlet temperature, and 80 psi lubricant jet pressure) were provided for two speeds and three load cases as described earlier. In Figure 10(a) drive motor power (amount of power to rotate the entire test rig) and in Figure 10(b) lubricant temperature rise (outlet minus inlet temperatures) is plotted versus bull gear shaft torque. From Figure 10(a) or (b) it can be seen that either the amount of power or the temperature rise was minimized using outward pumping configuration with shrouds. Outward pumping also required the most power or had the highest temperature rise if the shrouds were removed. When the gears were run with them pumping towards the gap, there was less of an effect with or without the shrouds.

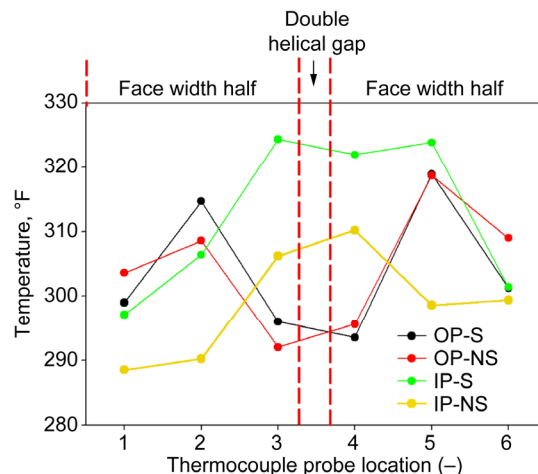

**Figure 8. Rake temperature as a function of location across the face width, 200 °F lubricant inlet temperature, 15000 rpm, 5000 hp (2nd to 3rd idler location).**

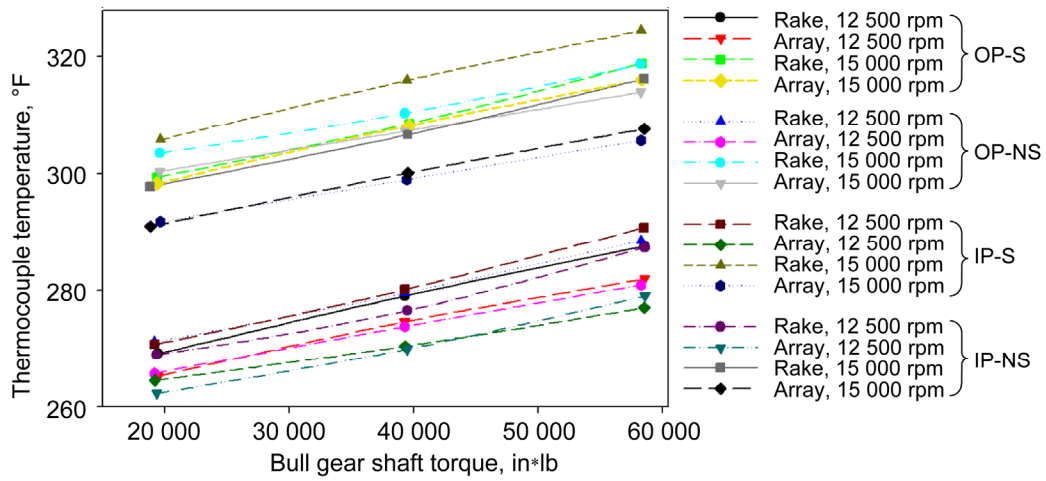

Figure 9. Maximum rake and array temperatures as a function of torque, speed, and shrouding (inward and outward pumping).

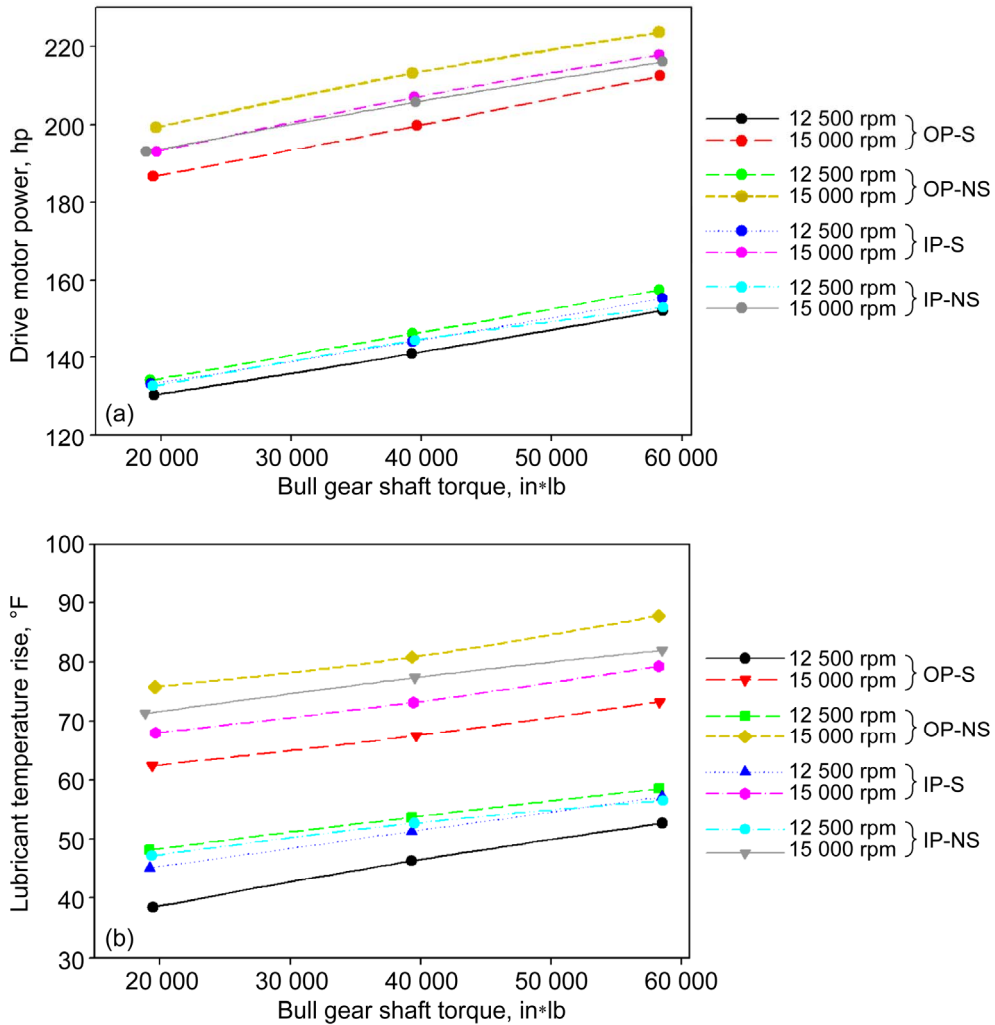

Figure 10. Effect of shrouding on drive motor power (a) and lubricant temperature rise (b).

## COMPARISON TO PRIOR TESTING

In this part of the paper the results from double helical gear testing will be compared to prior experimental results from single helical gears. As was shown earlier in this paper, two shaft speeds of interest will be shown with varying amounts of torque applied. The two speed levels pertain to the two tiltrotor flight operating conditions of hover (high shaft speed) and forward flight (lower shaft speed). Comparisons will be made for the amount of power to rotate the gear train in the test facility, amount of power absorbed by the lubricant (thermal efficiency), inlet lubricant jet pressure (lubricant flow), lubricant temperature increase across the gearbox, and thermocouple information from the radial and axial probes.

The first comparison, Figure 11, will be between the various configurations with respect to the amount of power to rotate the system at two rotational speeds with varying amounts of bull gear shaft torque. The single helical (SH) gear results are shown for superfinished (ISF) and conventionally ground (GRND) gear surfaces. All data is for shrouded (S) gear conditions. (In subsequent figures NS—means that the shrouds were removed for the test conditions.) For the conditions tested at the two different rotational speeds and three levels of bull gear torque, the double helical gears configured in the outward pumping, shrouded arrangement provided the lowest power loss at all conditions.

The next comparison is for power loss to the lubricant, Figure 12, between the various configurations shown. The level of losses (hp) were determined via the flow rate, lubricant properties, and the temperature differential from lubricant inlet to exit. In this figure, once again the double helical gear train had the lowest power loss for both speed and all loading conditions. This data is also for all configurations using shrouds.

Next the effect of lubricant system jet pressure (volumetric flow rate) is presented in Figure 13. The tests were all run at 33 percent of maximum torque and a 200 °F lubricant inlet temperature. As before, the data is contained in two “speed bands”. Lower jet pressure reduces the amount of lubricant available to keep the gear surfaces fully flooded and provide adequate cooling. In this facility the jets feed lubricant into and out of mesh. The lubrication system operates in a dry sump mode—all lubricant is jet fed and scavenged away by lubrication pumps. There is also concern

that by lowering the jet pressure, the jets cannot penetrate deep enough to the roots of the teeth so the level of loading was kept to 33 percent of maximum. The trends were that higher pressure (more cooling flow) reduced the temperature change from inlet to exit of the gearbox. Also the double helical outward pumping arrangement produced the lowest temperature increase for all conditions tested.

In Figure 14 the next comparison is made between the temperature change as a function of two speeds and three torque levels for six different gearing configurations. Once again the double helical, outward pumping configuration with shrouds had the lowest temperature rise for the lubricant between inlet and exit of the gearbox. Nearly all the data showed a linear dependence on the torque applied.

The last two Figure 15 and Figure 16 will show the temperature probe data for the single and double helical gear configurations. The thermocouple array maximum temperature differential is shown for two speeds and three torque levels, all at 200 °F lubricant inlet temperature. The temperature difference was found from the maximum thermocouple array measured minus the lubricant inlet temperature (~200 °F). For this data, one can see three bands of data. The single helical gears have a much higher temperature differential from the array probe thermocouples than the double helical gears. The double helical, inward or outward pumping gears, had a similar result for temperature difference at 15000 rpm as the single helical at 12500 rpm. Also the double helical gear configurations at 12500 rpm were the lowest. An explanation for this is fairly straightforward. Since a single helical gear has the entire face width to pump the entrapped lubricant—air environment, it would be expected to have a much higher exit (array) temperature as opposed to one only moving across approximately half the face width.

The last comparison to make will be with the rake probes that measured the air- lubricant being flung radially from the gear teeth. In Figure 16 the temperature differences between the maximum rake temperature and lubricant inlet temperature is plotted versus applied torque for the two speed conditions (12500 and 15000 rpm). All test data shown was taken with shrouds in place. At the 12500 rpm input shaft speed, all data was within ~7 °F of each other. At the higher speed conditions, both double helical gear configurations were better with the outward pumping double helical configuration being the best at all torque conditions.

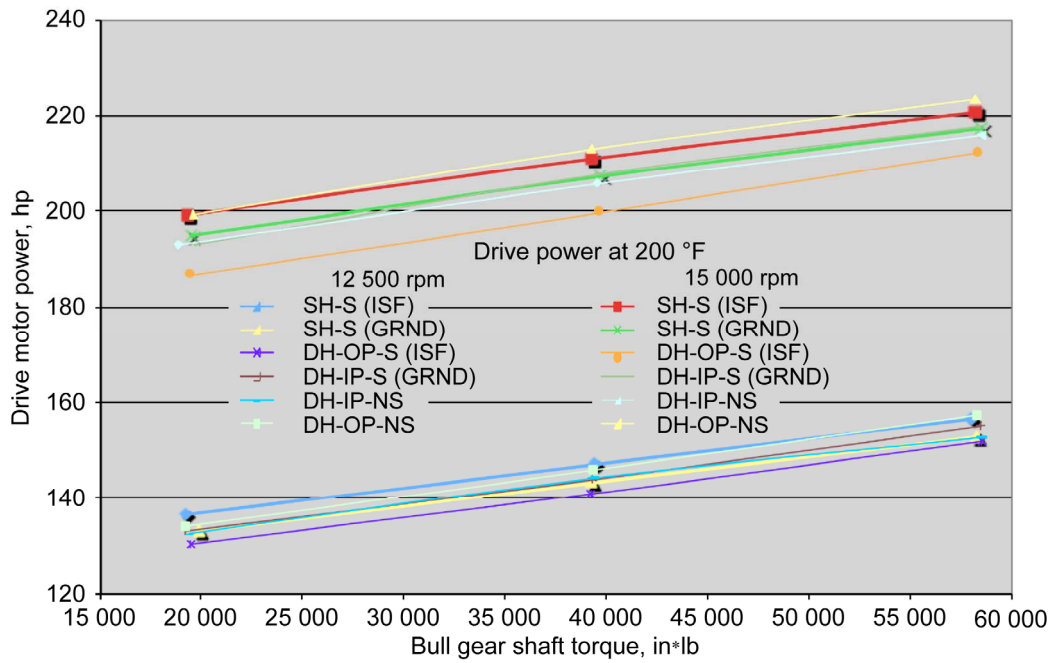

Figure 11. Drive motor power versus torque, two speeds at 200 °F oil in temperature.

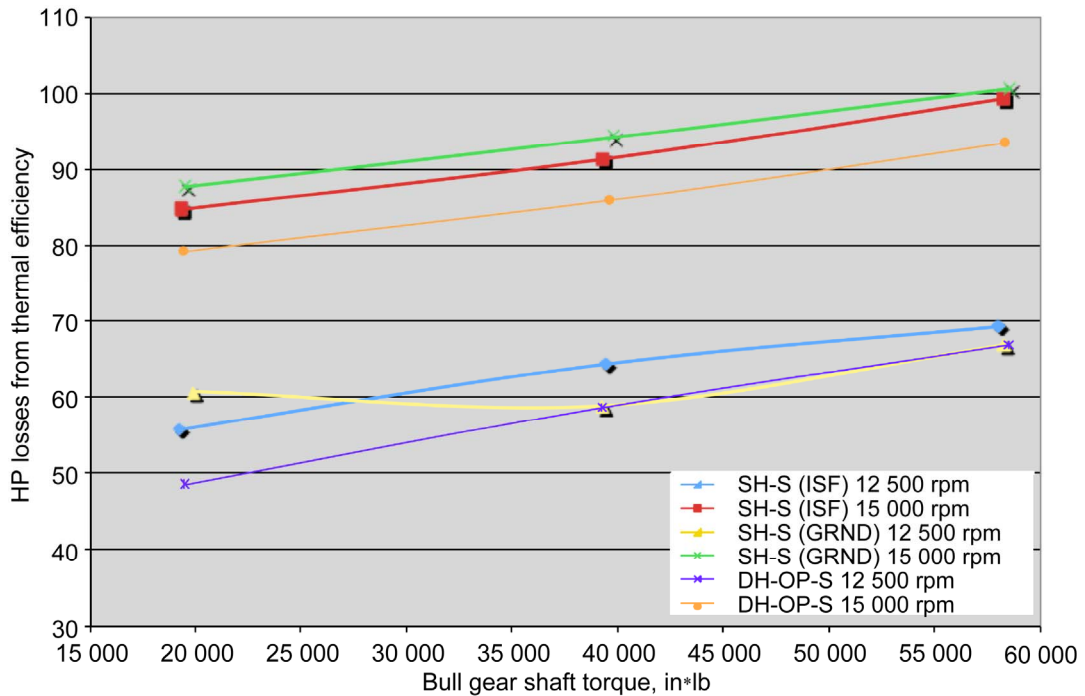
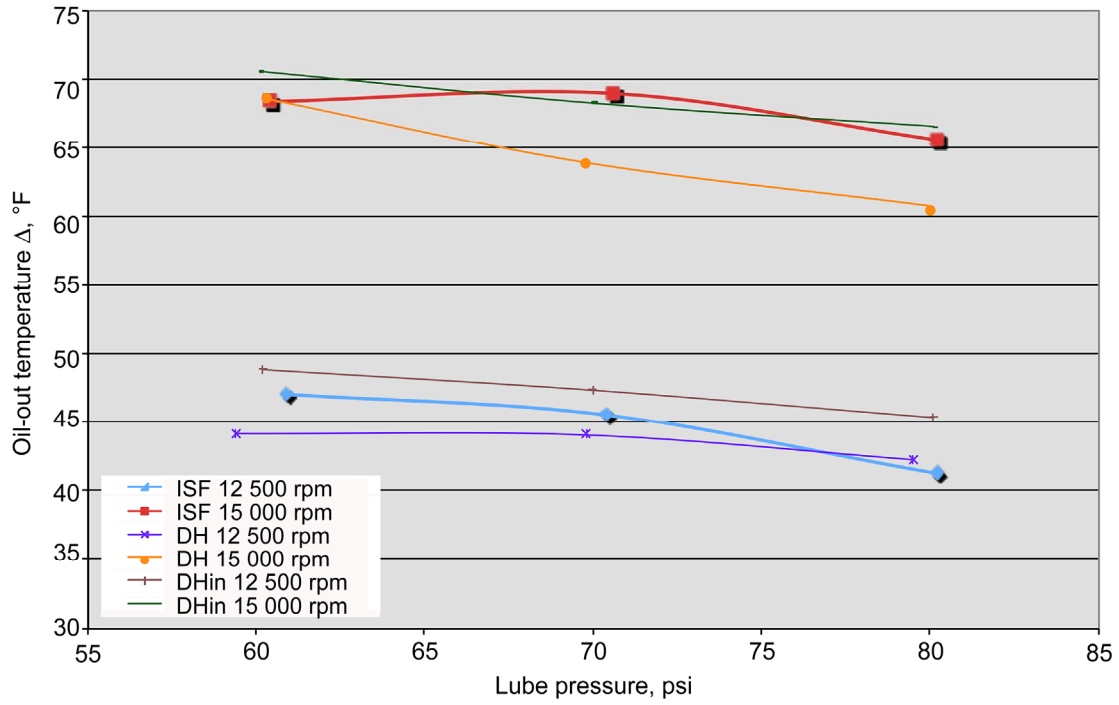
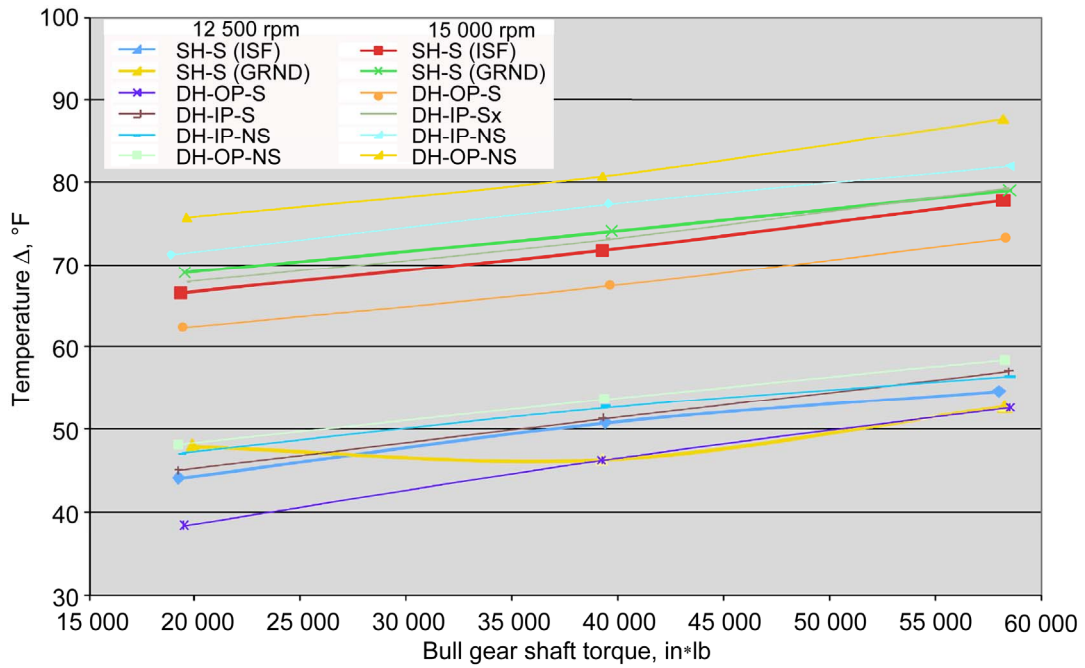

Figure 12. Power losses versus torque, two speeds at 200 °F oil—in temperature.

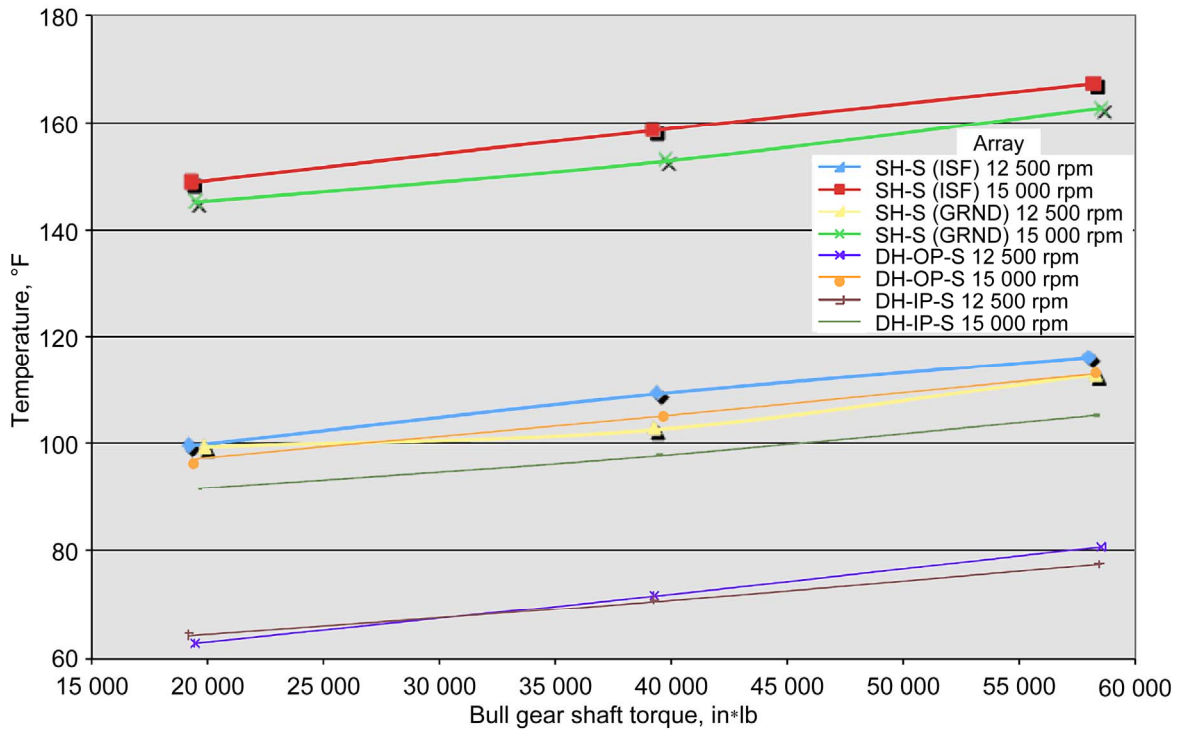

**Figure 13. Temperature change of the lubricant versus pressure at 200 °F, two speeds, 19000 in\*lb torque at bull gear shaft.**

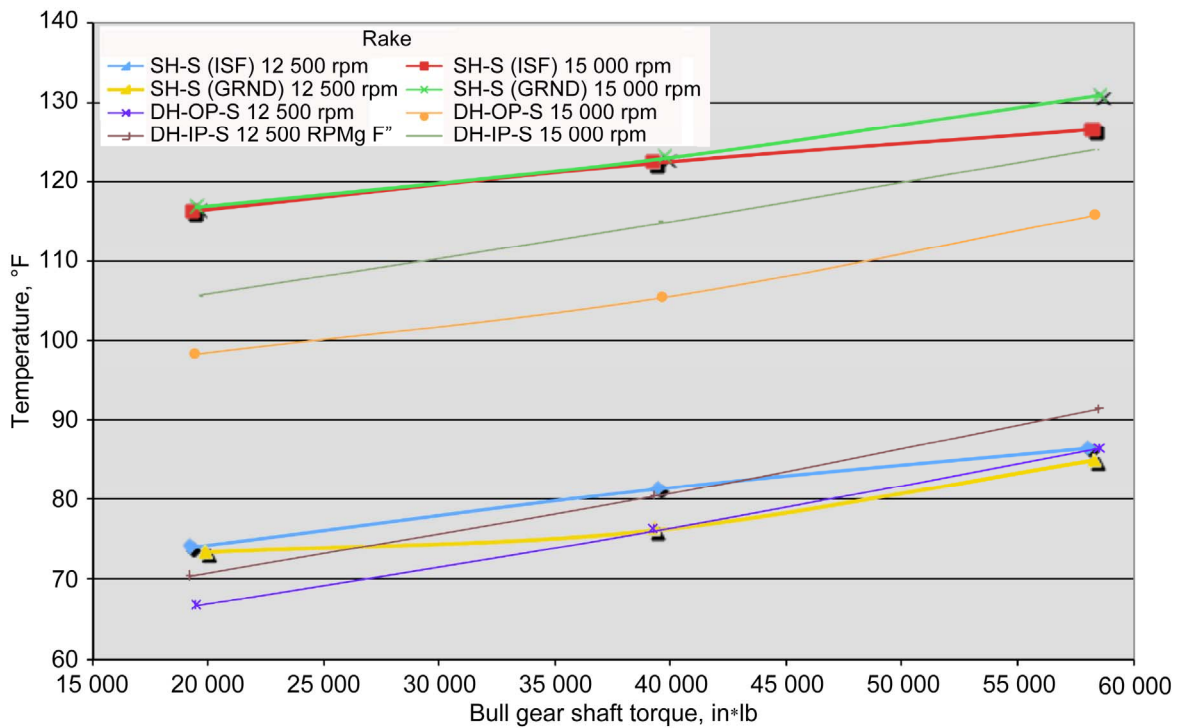

**Figure 14. Temperature change of lubricant versus torque, two speeds at 200 °F.**





**Figure 15. Temperature of array thermocouple maximum difference from inlet temperature versus torque at two speeds, 200 °F lubricant inlet temperature.**



**Figure 16. Temperature change of oil inlet to maximum rake probe data versus torque, two speeds, 200 °F lubricant inlet temperature.**

## CONCLUSIONS

Based on the results found in this study and those conducted previously the following observations can be concluded

1. Double helical gear trains that outwardly pump the air—lubricant mixture axially produced the highest performance when compared to other tested conditions that included inward pumping double helical gears and single helical gear trains (ground and superfinished).
2. Double helical gear trains that have an inward pumping arrangement produced similar performance results with or without shrouds. The results from these tests were in between the outward pumping arrangement being better than outward pumping without shrouds and not as good as outward pumping with shrouds. This was found in both the drive motor power needed to rotate the entire test facility as well as the temperature change of the lubricant across the gearbox (difference between inlet and outlet lubricant temperature).
3. The double helical, outward pumping shrouded arrangement was also the best when lubricant pressure was reduced, providing the lowest temperature increase at nearly all conditions.
4. Temperature probes were used to measure the radial and axial air—lubricant environment as the gears were tested. The array probe temperatures were much higher for the single helical (ground or superfinished) in comparison to either inward or outwardly pumped configurations. In the case of a single helical gear the array probe will measure the air—lubricant that is pumped some distance across the face width in comparison to the double helical gear system that might only be half the distance for the case of outward pumping. The data from the rake probes

showed that the most significant difference was at the 15000 rpm condition with the double helical gear, outward pumping arrangement being the one with the lowest temperature increase between the oil inlet temperature and the maximum rake probe temperature.

## REFERENCES

1. Kilmain, C., Murray, R., and Huffman, C.: V-22 Drive System Description and Design Technologies, American Helicopter Society 51st Annual Forum, May 1995.
2. Handschuh, R. and Kilmain, C: Preliminary Investigation of the Thermal Behavior of High-Speed Helical Gear Trains, NASA/TM—2002-211336, ARL-TR-2661, March 2002.
3. Handschuh, R. and Kilmain, C.: Efficiency of High-Speed Helical Gear Trains, NASA/TM—2003-212222, ARL-TR-2968, April, 2003.
4. Handschuh, R. and Kilmain, C.: Preliminary Comparison of Experimental and Analytical Efficiency Results of High-Speed Helical Gear Trains, ASME 2003 Design Engineering Technical Conference, September 2003, Chicago, IL.
5. Handschuh, R. and Kilmain, C.: Experimental Study of the Influence of Speed and Load on Thermal Behavior of High-Speed Helical Gear Trains, NASA/TM—2005-213632, ARL-TR-3488, July 2005.
6. Handschuh, R. and Kilmain, C: Operational Influence on Thermal Behavior of High-Speed Helical Gear Trains, NASA/TM—2006-214344, ARL-TR-3969, November 2006.
7. Handschuh, R.; Kilmain, C.; Ehinger, R.: Operational Condition and Superfinishing Effect on High-Speed Helical Gearing System Performance, NASA/TM—2007-214696; ARL-TR-4099, June, 2007.