



Apollo Lunar Module Electrical Power System Overview

Objectives

- Describe LM Electrical System original specifications
- Describe the decision to change from fuel cells to batteries and other changes
- Describe the Electrical system
- Describe the Apollo 13 failure from the LM perspective

Lunar Module (LM) electrical system designed for:

- Low power during coast to Moon
- High loads during lunar descent
- Lower loads during lunar ascent
- Redundant power supply such that entire mission (although shortened) could be done if one system on ascent or descent stage was lost

Original Requirements

- 65 kW-hr at 4 kW max for a 35-hr lunar stay
- Designed fail-safe
 - Redundant buses, isolation equipment
 - Converters for equipment needing other than 28 V DC
 - Circuit protection by circuit breakers, fuses, electronic circuitry
- Originally designed for fuel cells
 - Three fuel cells
 - Peaking battery and battery charger

Power Source Changes

Due to complexity, development costs, time constraints, and mission profile changes, off-the-shelf battery technology was used

- LM battery charger not needed (only for CSM)
- Decreased time between lunar liftoff and docking meant lower power requirements
- Took a 45.35kg (100 lb) weight hit to LM by switching to batteries
- Later mission increased lunar stay time from 35 to 72 hrs required extra batteries

Battery Specs.

	LM Descent	LM Ascent	CSM Entry/ Post-Landing
Voltage (volts)	29	29	29
Capacity (amp-hrs)	400	296	40
Dimensions Length Width Height	0.025m ³ (1525.3 in ³) 0.43m (16.94") 0.23m (9.04") 0.25m (9.96")	0.022m ³ (1376.8 in ³) 0.90m (35.75") 0.12m (4.95") 0.2m (7.78")	0.006m ³ (373.5 in ³) 0.25m (10.15") 0.16m (6.4") 0.15m (5.75")
Weight	60kg (132.7lbs)	56kg (123.7lbs)	10kg (22lbs)
Quantity	4 or 5	2	3

Final Configuration

- Seven batteries
 - Five descent-stage @ 400 amp-hrs each
 - Two ascent-stage @ 296 amp-hrs each
- Electrical Control Assembly (ECA)
 - For control and protection of batteries
 - 2 for descent and 2 for ascent
- Redundant feeder systems
 - Get the power from the batteries to the buses
- Deadface assembly
 - Separate the descent stage from the ascent stage via Explosive Device Subsystem (which has its own separate power system)
- DC buses feed AC converters

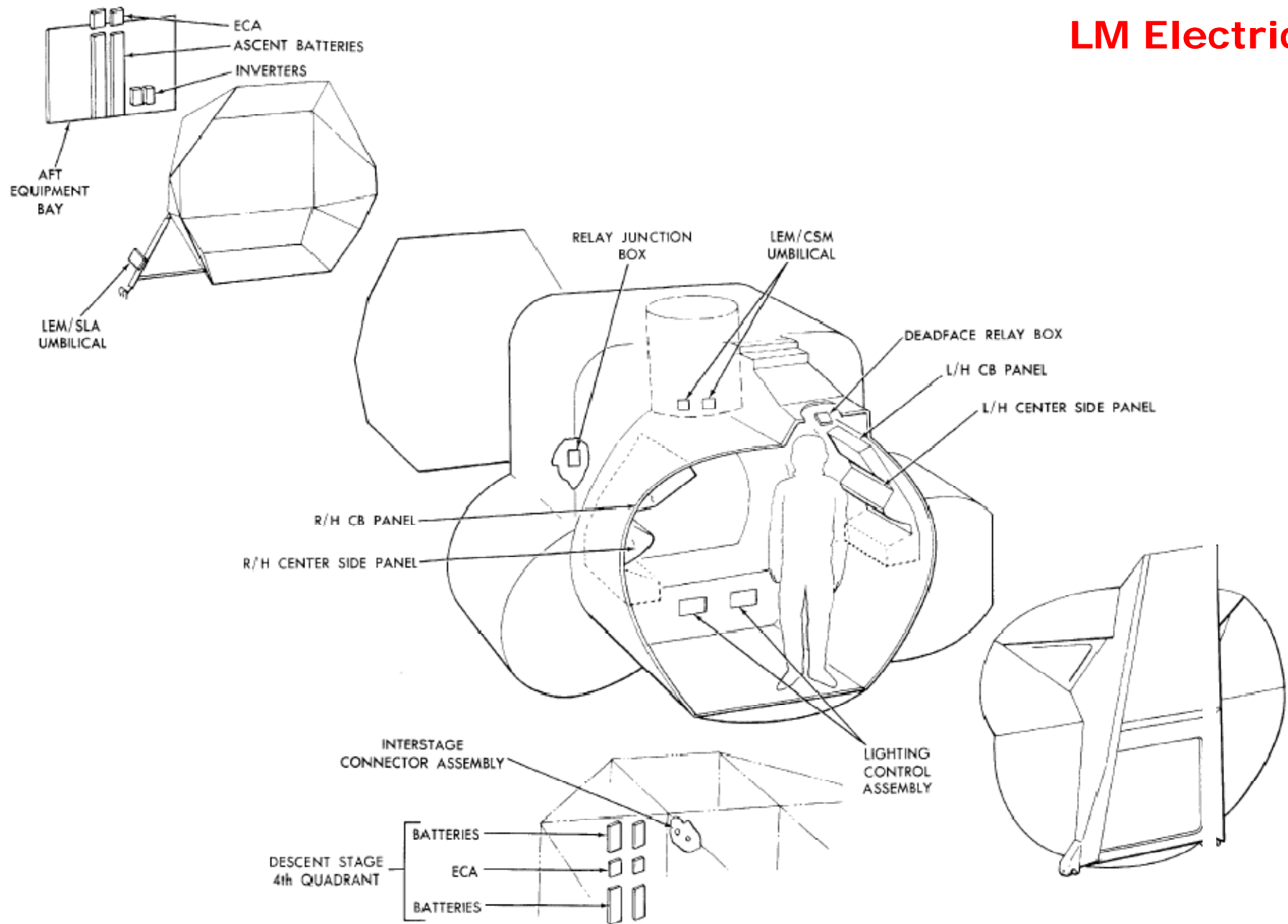

Other Changes

AC System

- Most of the ECLSS pumps and fans changed to brushless DC motors instead of AC motors, so they ended up with oversized AC inverters

Design changes as a result of Apollo 13

- Capability of the LM to initiate power transfer to CSM
- Added circuit protection to LM buses during power transfer
- Capability to transfer power after LM staging
- Added fifth descent stage battery (Lunar Battery), 12 kW
- Any battery could be tied to any electrical bus

LUNAR MODULE POWER SYSTEM

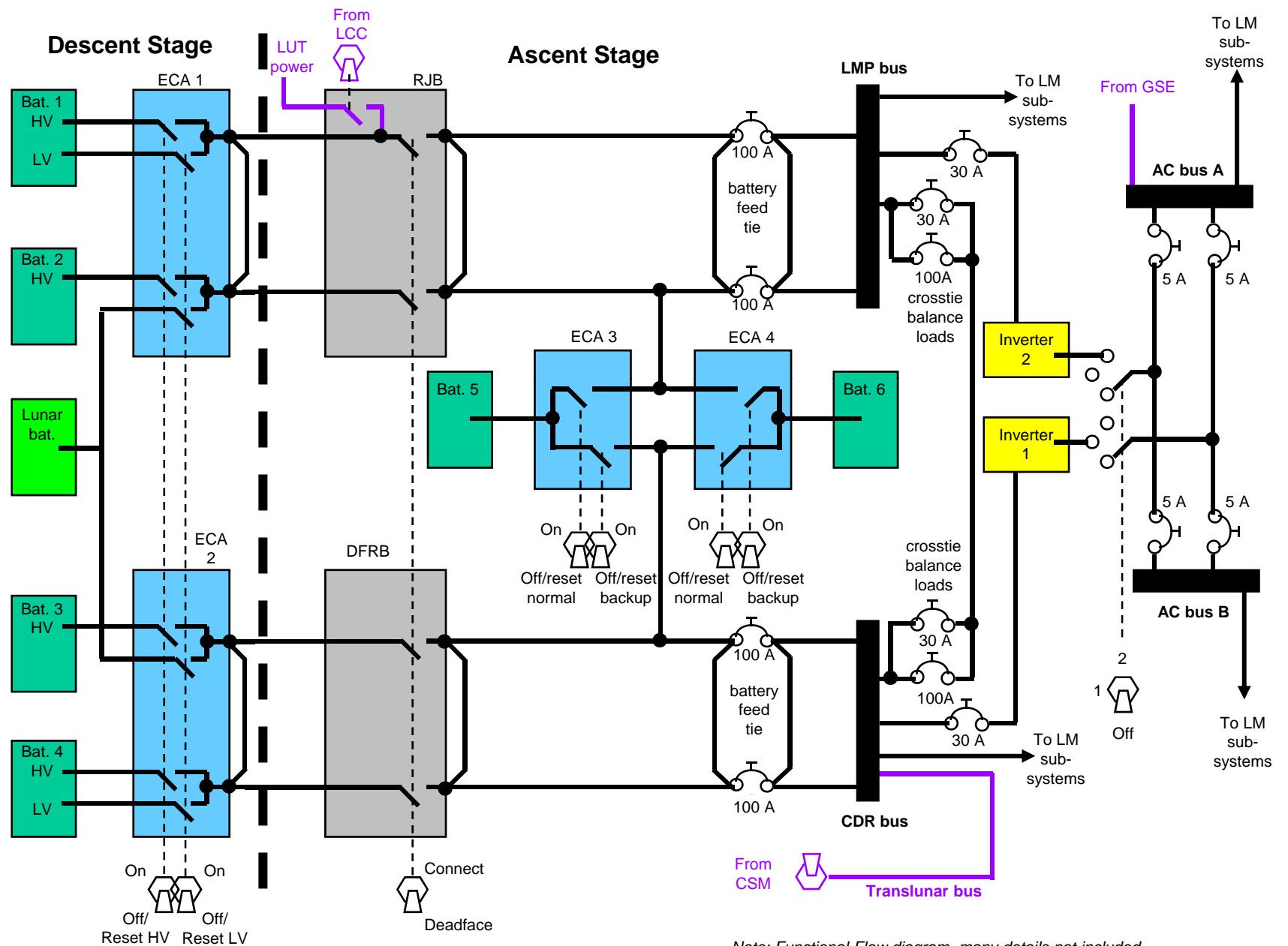

Note: Functional Flow diagram, many details not included

LUNAR MODULE POWER SYSTEM *Battery subsystem*

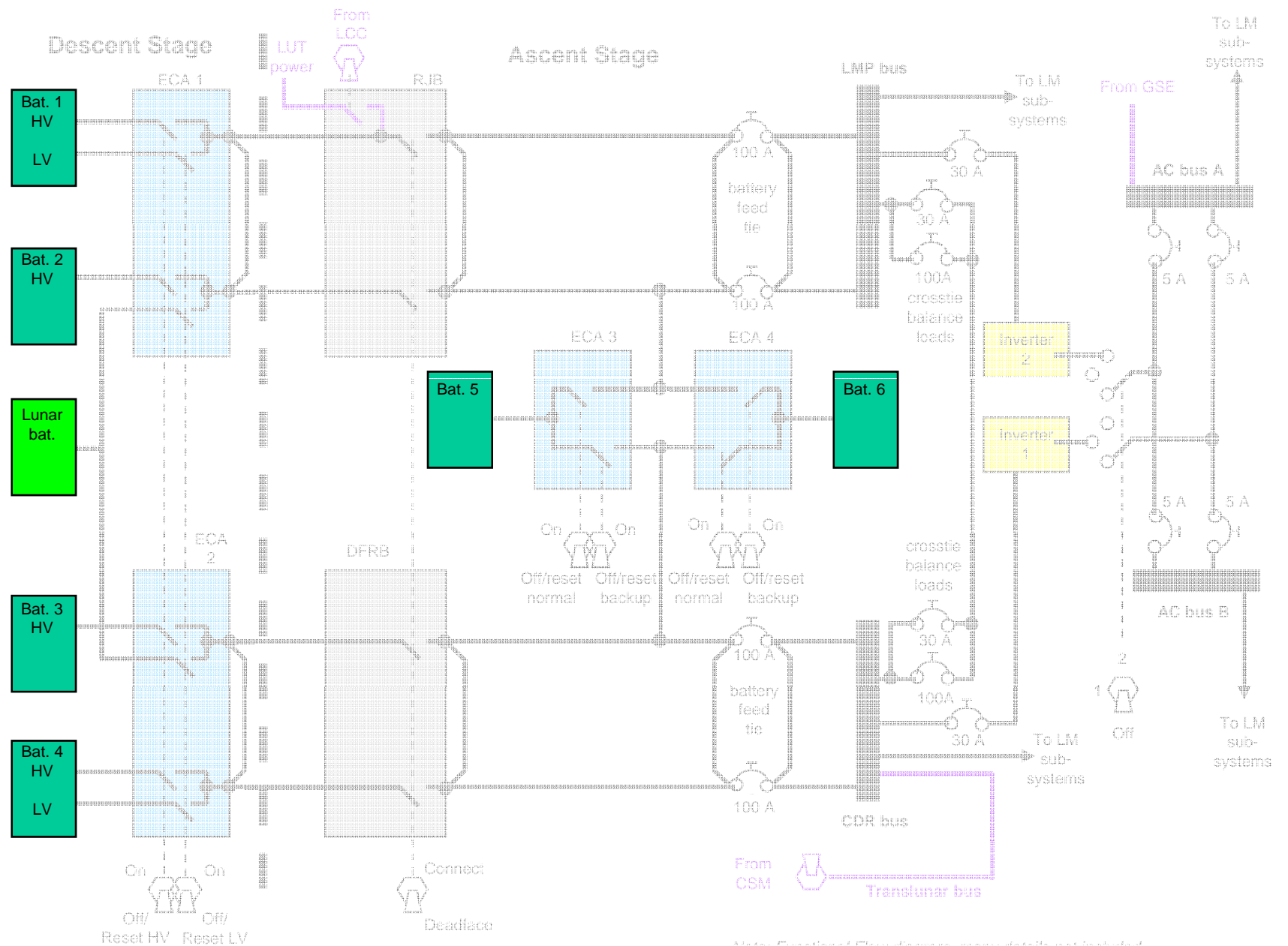

Note: Functional Flow diagram, many details not included

Battery Subsystem

- Timeline
 - Prior to docking: DC power from low-voltage taps on descent stage batteries.
 - Descent: all 7 Ascent and Descent batteries were paralleled
 - Ascent: Ascent batteries activated, Descent batteries deactivated, lines deadfaced and severed
- Loss of a single battery
 - If Descent stage, led to curtailed mission, but other battery could handle loads on the main bus
 - If Ascent stage, enough to accomplish liftoff, rendezvous, and docking.
- Lunar Battery was a spare added after Apollo 13
 - Could be connected to either bus (but not both simo).

LUNAR MODULE POWER SYSTEM

Electrical Control Assembly subsystem

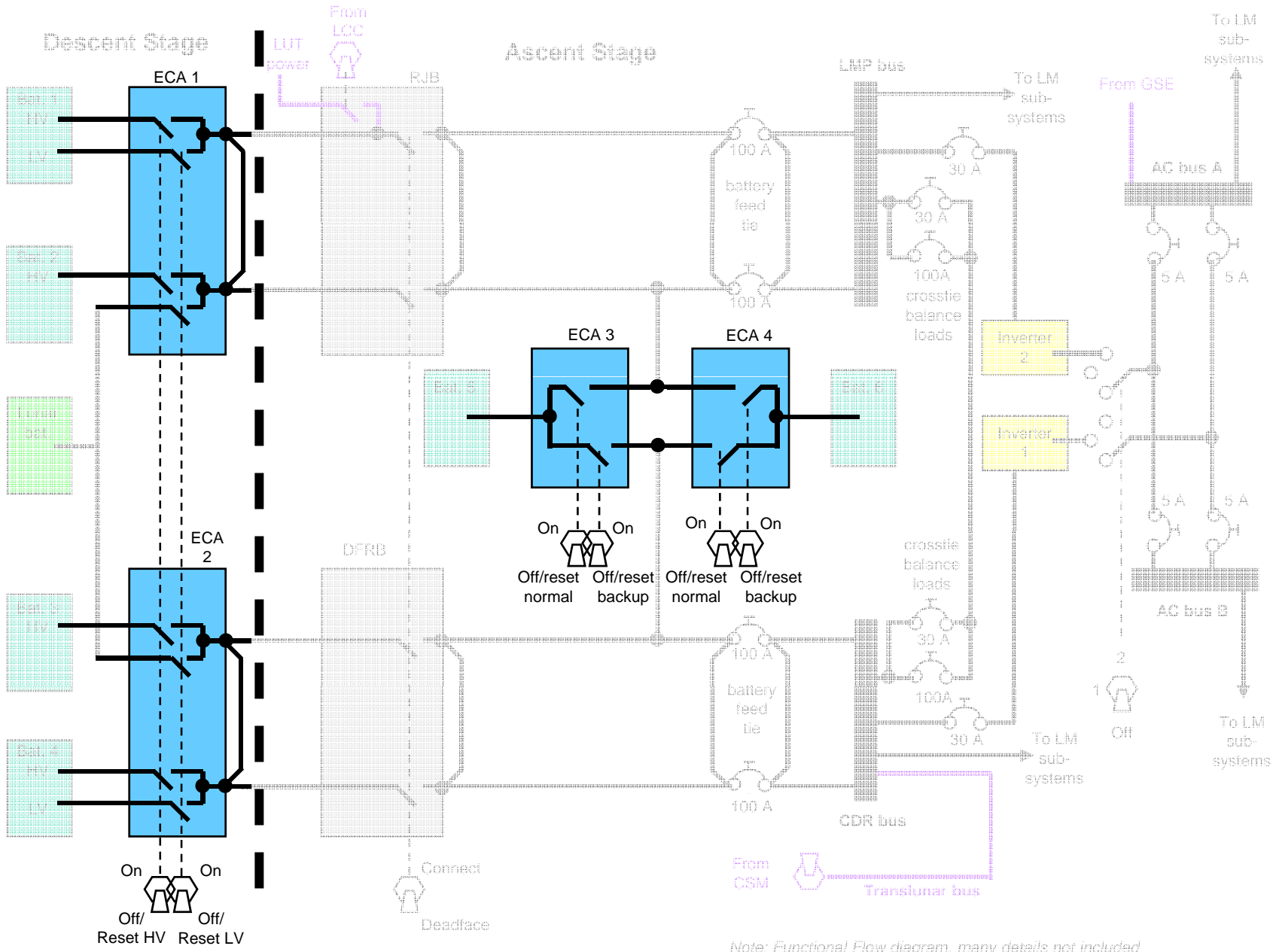

Electrical Control Assembly

Batteries controlled and protected by four electrical control assemblies (ECAs)

- Two Descent stage ECAs allowed high and/or low voltage onto the buses
- Two Ascent stage ECAs provided a primary and backup path from the batteries to the buses.

ECAs provided auto-trip protection

- In case of overcurrent, reverse current, or overtemp

LUNAR MODULE POWER SYSTEM Interface Control subsystem

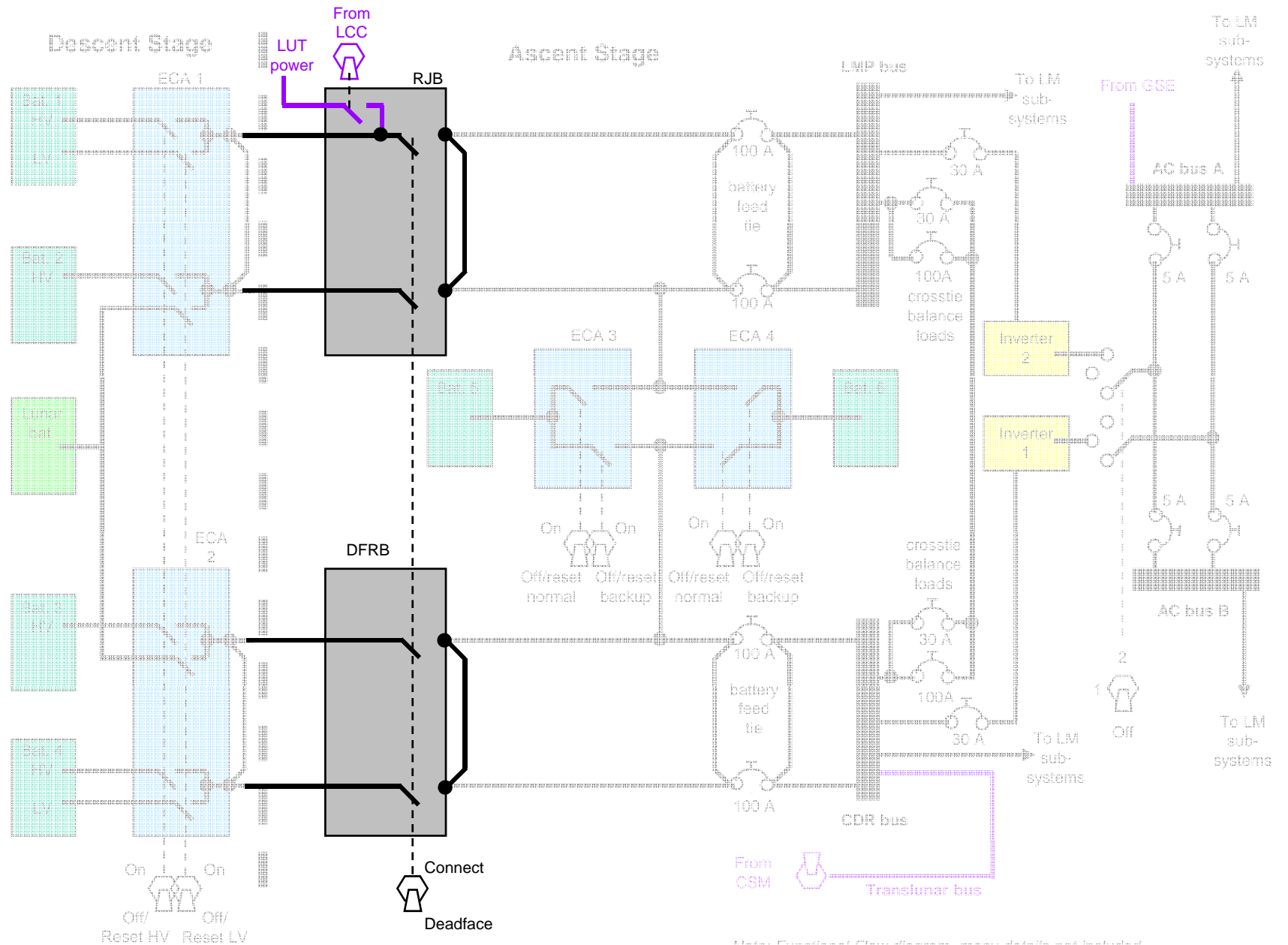

Note: Functional Flow diagram, many details not included

Interface Control

Junction boxes on feeder wires between batteries and electrical buses

- Disconnected, deadheaded, and isolated Descent stage from the Ascent stage prior to liftoff from the lunar surface

Deadface Relay Box (DFRB) on CDR's side

Relay Junction Box (RJB) on the LMP side

- RJB had additional relays and electronics for the various battery controls from the automatic checkout equipment, the LM cabin, and the command module (CM).
- Also contained the relays that connected the Launch Umbilical Tower (LUT) to the LM prior to launch.

LUNAR MODULE POWER SYSTEM *DC Feeder subsystem*

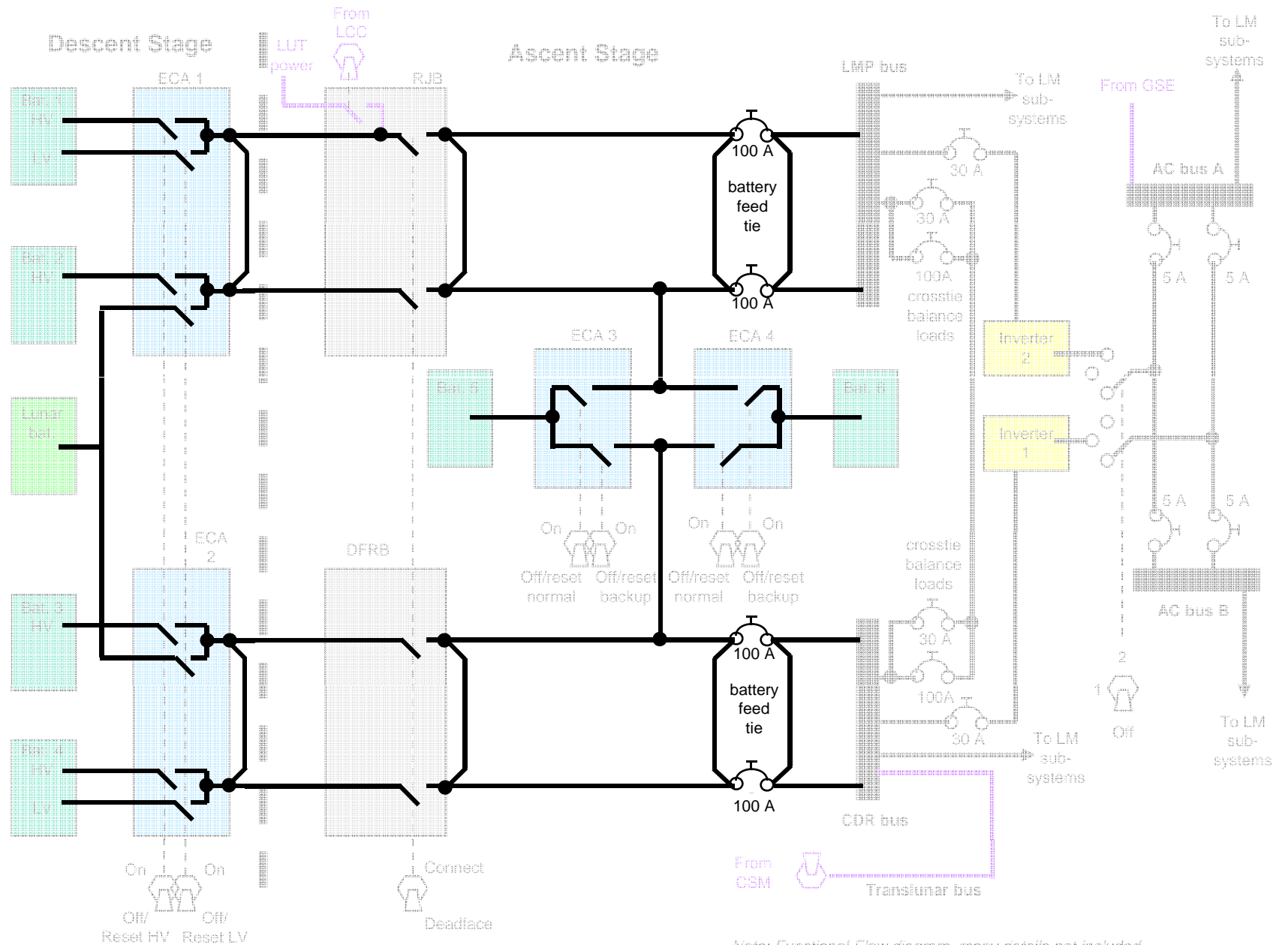

Note: Functional Flow diagram, many details not included

Feeder System

Two feeder systems consisting of redundant power wires to transfer power from the batteries through the ECA to the DC buses.

- For the Descent stage, both high and low voltage distribution feeder connections had automatic overcurrent protection in the ECA
- For the Ascent stage, autotrip for backup feeder was removed for weight savings

LUNAR MODULE POWER SYSTEM *DC Bus subsystem*

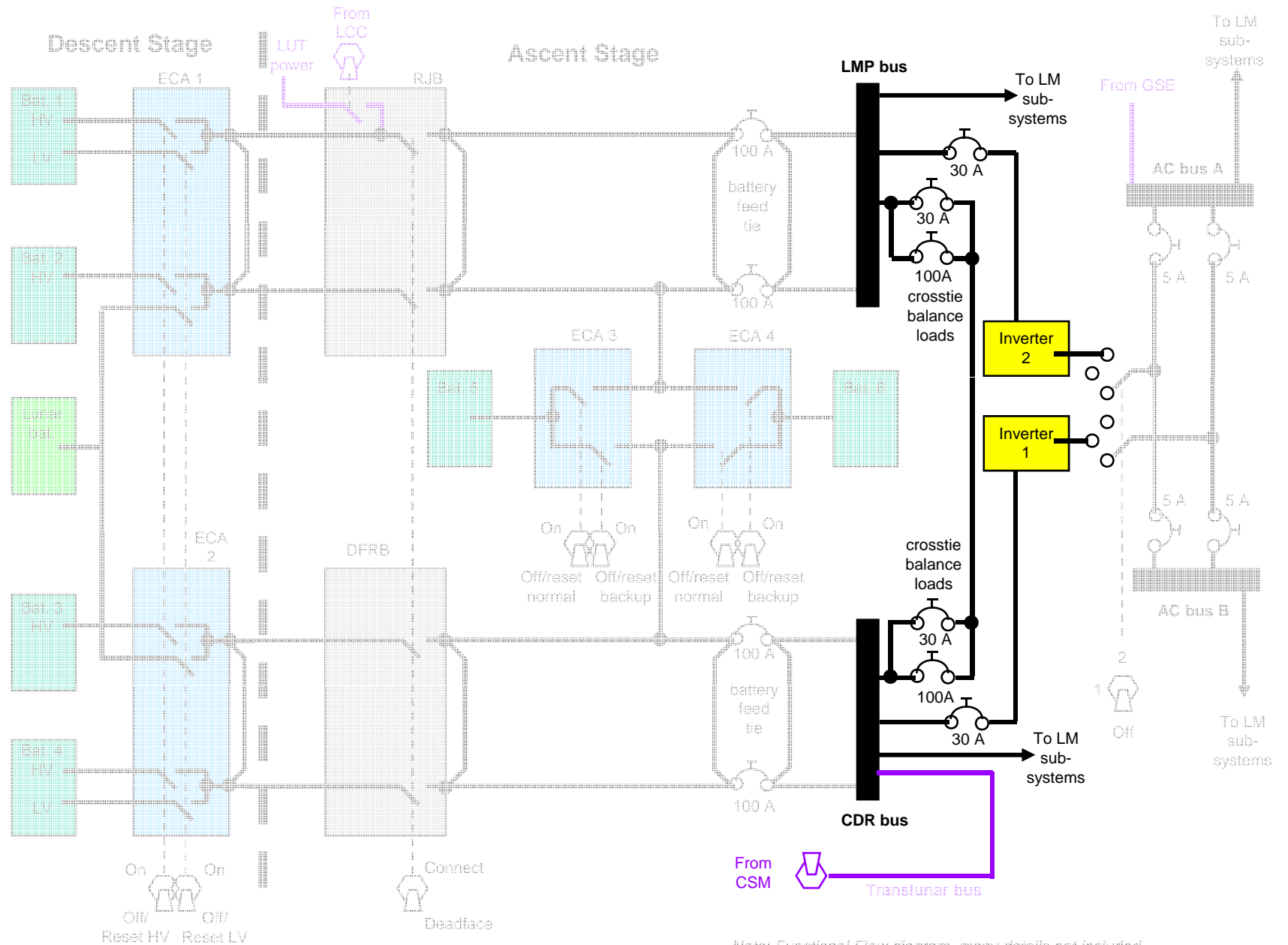

Note: Functional Flow diagram, many details not included

DC Bus System

DC electrical power was distributed via the LMP and CDR buses

- So named because of the switches and circuit breakers on that crewmember's side of the LM
- DC power went to other subsystems directly from these buses
- DC power was also distributed to the AC inverters

DC Bus Operations

During noncritical phases of normal operation

- 30-amp cbs were closed to distribute unbalanced loads between buses so that the batteries discharged evenly.
- Between docking and descent, CSM supplied power to the LM at the CDR bus using the CSM Translunar Negative Bus

During critical phases of normal operation

- Descent and Ascent stage batteries paralleled during descent operations
- CDR and LMP buses were isolated

DC Load Grouping

Redundant loads were put on separate buses

- Examples: two AC inverters, the system A and B reaction-control quad heaters with control circuitry, the two sets of UHF and VHF transceivers, primary guidance (PGNS), abort guidance (AGS)

Nonredundant critical loads powered by both buses with diode protection

- Example: battery controls

Nonredundant noncritical loads powered by a single bus

- Examples: sensors, some lights

LUNAR MODULE POWER SYSTEM *AC subsystem*

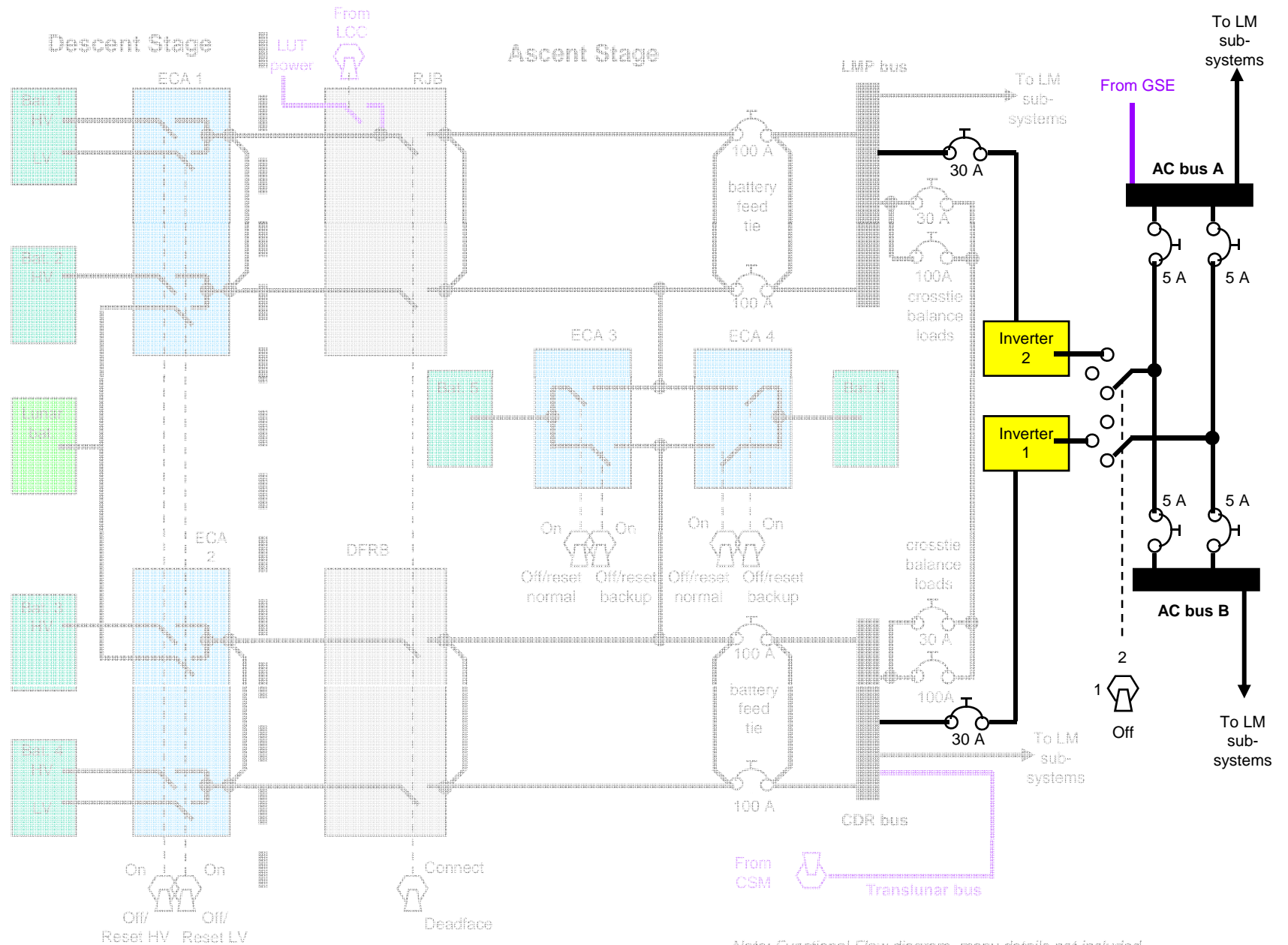

Note: Functional Flow diagram, many details not included

AC Subsystem

AC power provided by either of two identical, redundant inverters, one from each main bus

- Inverter 2 energized when the LM subsystems first activated and connected to the AC buses.
- Inverter 1 functioned as a backup during the mission, except that it was the operating inverter during LM descent and ascent engine burns.

The AC bus A also received power from the GSE prior to launch

LUNAR MODULE POWER SYSTEM *Outside power sources*

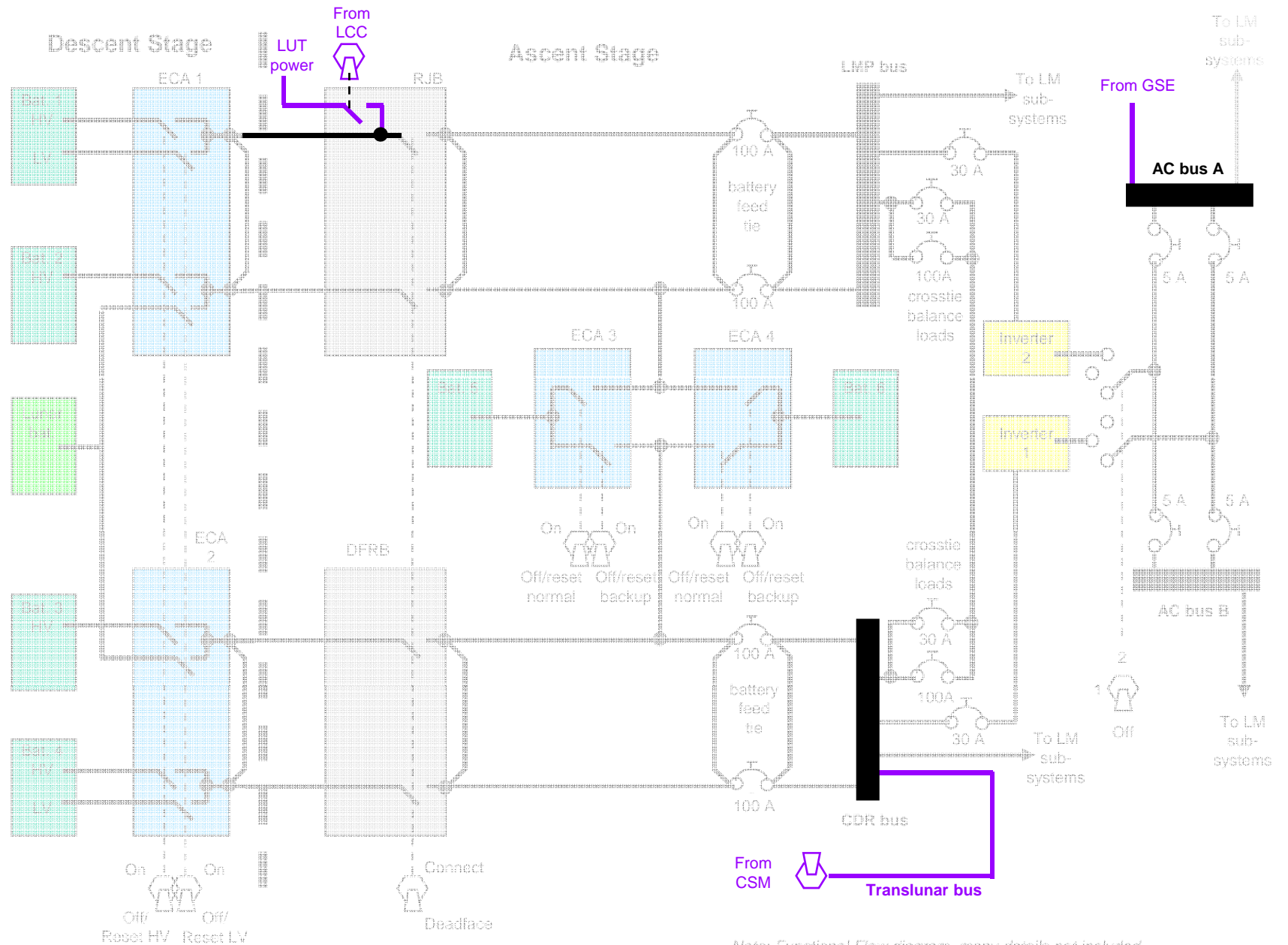

Note: Functional Flow diagram, many details not included

Outside Power Sources

Prelaunch

- From LUT (DC) and GSE (AC)

Translunar coast

- Used between docking and descent operations
- Translunar Negative Bus, which transferred DC power from the CSM to the LM via umbilicals for various heaters and lights during the translunar coast

Timeline

Time	LM power supply
Prior to T-30 min	GSE
T-30 to transposition and docking	LM Descent batteries
Translunar coast	CSM via the Translunar Bus
Lunar orbit	LM Descent batteries
Lunar descent	LM Ascent and Descent batteries
Lunar surface stay	LM Descent batteries
Lunar ascent	LM Ascent batteries

Apollo 13 (as seen from the LM)

Cryo tank explosion on Service Module led to impending loss of all power in the CSM

- Only remaining power source in CSM were Entry/Post-Landing Batteries, and they were partly discharged

Used Translunar Negative Bus to power CSM from LM

- Normally the CSM powered the LM during the translunar coast via drag-through umbilicals
- LM used as a “lifeboat” to power critical equipment on CSM and to recharge the CSM Entry batteries
- LM not designed to be brought back to Earth
- Severe powerdowns on both LM and CSM were required (at some points, less than 20% of normal power levels)

Apollo 13 LM Batteries

LM batteries provided power to itself and the CSM for 83 hrs

- Far outside of qual/testing limits
- Provided 350W, normally 1000W
- Continuous zero-G
- Continuous cold temperatures (37° F)
- At jettison, the LM had less than 5 hrs of power left

Extra “Lunar Battery” added afterwards due to longer lunar stays

- Could also be used as extra power in emergency scenario
- Coincidentally already planned for Apollo 15-up

LUNAR MODULE POWER SYSTEM *Apollo 13*

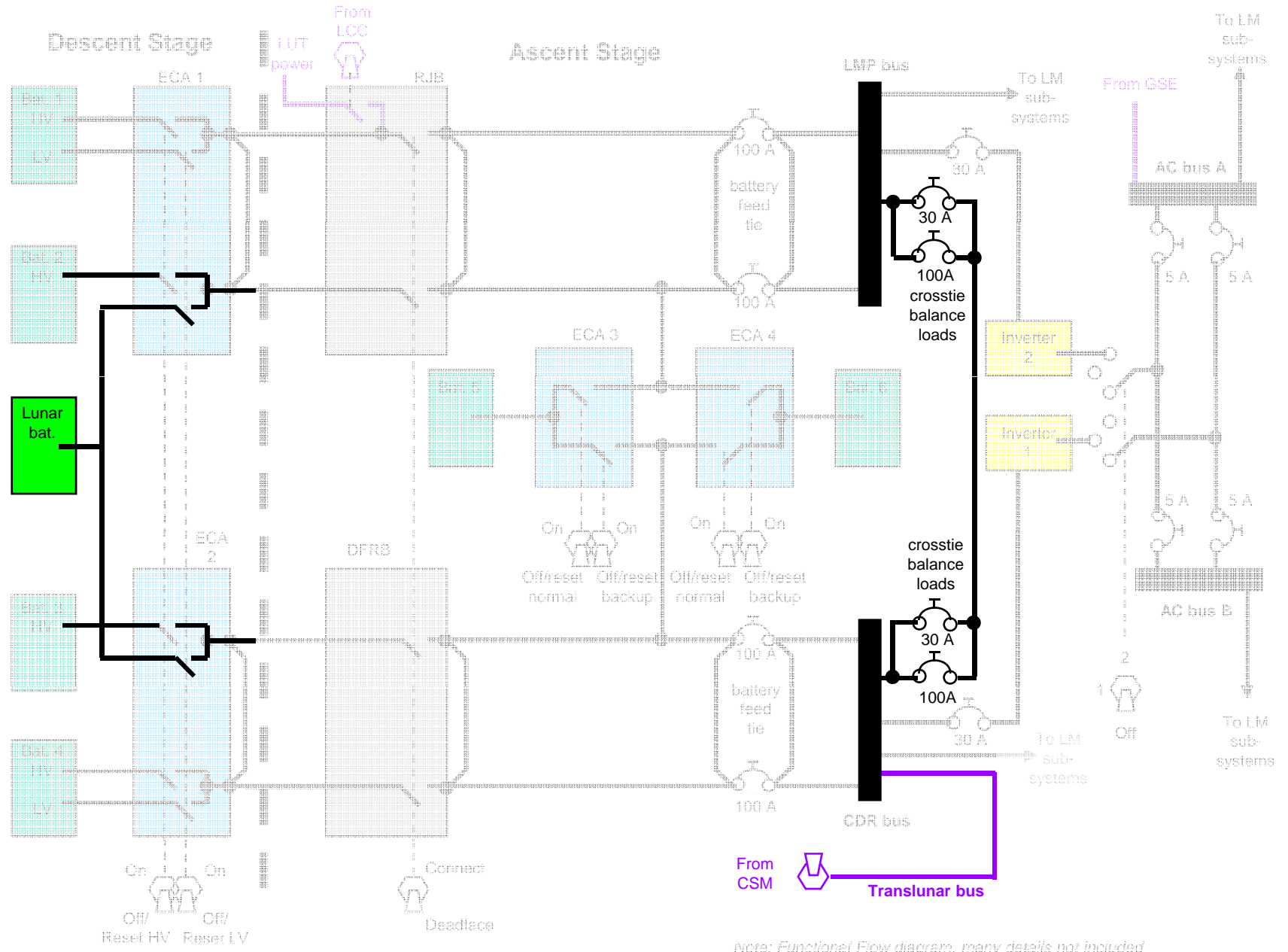

For More Information

Apollo Experience Reports

Battery Subsystem, NASA Technical Note TN D-6976, 09/72

Lunar Module Electrical Power Subsystem, NASA Technical Note TN D-6977, 09/72

Apollo Operations Handbook

Lunar Module, LM 10 and Subsequent, Volume 1: Subsystem Data, Grumman document LMA790-3-LM10, 04/71

Lunar Excursion Module Familiarization Manual

Grumman document LMA790-1, 10/65

Apollo Mission Familiarization for Constellation Personnel

Apollo Wiki