

REC'D JAN 12 1948

~~CONFIDENTIAL~~

COPY NO. 1
RM No. SE7K16

~~CLASSIFICATION CHANGED TO~~

~~SECRET~~

~~CONFIDENTIAL~~

~~CONFIDENTIAL~~
NACA

Source of Acquisition
CASI Acquired

898
NACA changed 1459

RESEARCH MEMORANDUM

for the

Bureau of Aeronautics, Navy Department

EFFECT OF AIR-FLOW DISTRIBUTION AND TOTAL-PRESSURE LOSS

ON PERFORMANCE OF ONE-SIXTH SEGMENT

OF TURBOJET COMBUSTOR

By Francis U. Hill and Herman Mark

Flight Propulsion Research Laboratory
Cleveland, Ohio

Restriction/
Classification
Cancelled

CONFIDENTIAL

~~CONFIDENTIAL~~
CLASSIFICATION CANCELLED

CLASSIFIED DOCUMENT
This document contains classified information affecting the national defense of the United States within the meaning of the Espionage Laws. The transmission or revelation of its contents in any manner to an unauthorized person is prohibited by law. Information so classified may be imparted only to persons in the military and naval Services of the United States, appropriate civilian officers and employees of the Federal Government who have been indoctrinated therein, and to United States citizens of known loyalty and discretion who of necessity must be informed of the facts.

TECHNICAL
EDITING
WAIVED
NACA changed 2175

NATIONAL ADVISORY COMMITTEE
FOR AERONAUTICS **FILE COPY**

WASHINGTON

To be returned to
the files of the National
Advisory Committee
for Aeronautics
Washington, D. C.

DECEMBER 10 1947

~~CONFIDENTIAL~~
CLASSIFICATION CANCELLED

20

NATIONAL ADVISORY COMMITTEE FOR AERONAUTICS

RESEARCH MEMORANDUM

for the

Bureau of Aeronautics, Navy Department

EFFECT OF AIR-FLOW DISTRIBUTION AND TOTAL-PRESSURE

LOSS ON PERFORMANCE OF ONE-SIXTH SEGMENT

OF TURBOJET COMBUSTOR

By Francis U. Hill and Herman Mark

SUMMARY

An investigation has been conducted on a one-sixth segment of an annular turbojet combustor to determine the effects of modification in air-flow distribution and total-pressure loss on the performance of the segment. The performance features investigated during this series of determinations were the altitude operational limits and the temperature-rise efficiency.

Altitude operational limits of the combustor segment, for the 19XB engine using the original combustor-basket design were approximately 38,000 feet at 17,000 rpm and 26,000 feet at 10,000 rpm. The altitude operational limits were approximately 50,000 feet at 17,000 rpm and 38,000 feet at 10,000 rpm for a combustor-basket design in which the air-passage area in the basket was redistributed so as to admit gradually no more than 20 percent of the air along the first half of the basket. In this case the total-pressure loss through the combustor segment was not appreciably changed from the total-pressure loss for the original combustor-basket design.

Altitude operational limits of the combustor segment for the 19XB engine were above 52,000 feet at 17,000 rpm and were approximately 23,000 feet at 10,000 rpm for a combustor-basket design in which the distribution of the air-passage area in the basket was that of the original design but where the total-pressure loss was increased to 19 times the inlet reference kinetic pressure at an inlet-to-outlet density ratio of 2.4. The total-pressure loss for the original design was 14 times the inlet kinetic reference pressure at an inlet-to-outlet density ratio of 2.4.

For the four operating conditions of altitude and engine speed at which temperature-rise efficiencies were investigated for the 19B engine, the combustor-basket design in which the air-passage area in the basket was redistributed to allow 20 percent of the air to enter the first half of the basket and where the total-pressure loss was increased over that for the original combustor design, consistently showed the highest temperature-rise efficiency. A temperature-rise efficiency of 97 percent was obtained for this design at sea level and 17,000 rpm. The temperature-rise efficiency was 92 percent for this design at 30,000 feet and 16,500 rpm.

INTRODUCTION

As a part of a general program requested by the Bureau of Aeronautics, Navy Department, to investigate the performance of 19B and 19XB combustors, a one-sixth segment of an annular turbojet combustor was built and investigated at the NACA Cleveland laboratory. The combustor was developed from the 19B and 19XB turbojet engine combustors. Modifications of this combustor were investigated in order to determine the effects of air-flow distribution and total-pressure loss through the combustor on the combustor performance.

Compressor and turbine characteristics of these engines were obtained from altitude-wind-tunnel investigations (reference 1) and are reproduced in figure 1. From these curves it can be seen that the altitude and engine speed determined the combustor-inlet conditions of pressure, temperature, and air flow and the turbine-inlet temperature required for engine operation.

The performance of the combustor segment and of each of the several modifications was investigated to determine the simulated altitudes and engine speeds at which the combustor could not furnish sufficient energy to operate the engine. The series of altitudes above which the combustor cannot meet this engine requirement at given engine speeds are hereinafter referred to as "the altitude operational limits". The altitude operational limits for the combustor segment give an indication of engine operating range.

Temperature-rise efficiency was determined at each of several combinations of combustor-inlet conditions for each modification of the combustor segment.

The results of the investigations made on the combustor segment are presented herein and are compared with the results of a similar investigation on the complete engine combustor (reference 2).

APPARATUS

Installation

The general arrangement of the installation is shown in figure 2. Air flow was vertically downward through the apparatus. Combustion air was supplied to the combustor inlet from the laboratory air system at pressures up to 30 pounds per square inch gage. The combustor exhausted past cooling-water sprays into the laboratory exhaust system, which could maintain pressures at 2 pounds per square inch absolute. Air flow and combustion-chamber pressure were regulated by means of two remote-control valves, one located upstream and one downstream of the combustion chamber.

In order to simulate combustor-inlet temperatures, a gasoline-burning preheater was located in a bypass in the air-supply line upstream of the combustor. Efficiency determinations run on this preheater indicated that a temperature rise of more than 95 percent of the theoretical value was obtained within the range of preheat over which the preheater was required to operate. The amount of carbon dioxide added to the inlet air never exceeded 2 percent and the assumption was made that this slight dilution would have little effect on combustor operation. Subsequent runs in which electrical preheaters were used verified this assumption.

Air flow was measured by means of a flat-plate, square-edged orifice, installed and calibrated according to A.S.M.E. specifications. The orifice installation was of the Daniel's type, facilitating the removal and change of orifice plates to the size yielding the most convenient and accurate manometer deflections. Fuel was fed from the laboratory supply system to a worm-type pump capable of delivering 8 gallons of fuel per minute up to pressures of 400 pounds per square inch gage. Calibrated rotameters were used to measure fuel flow. The fuel used for both the preheater and the combustor segment was AN-F-28, Amendment-2, and had a lower heating value of 18,600 Btu per pound and a carbon-hydrogen ratio of 0.174.

Four quartz observation windows were installed at intervals along the wall of the combustor segment for visual inspection of the combustion during operation.

Instrumentation for Measurement of Temperature and Pressure

At station 1 (fig. 3), iron-constantan thermocouples were used to measure inlet-air temperatures. At stations 2 and 3, banks of

chromel-alumel thermocouples were used for measuring the exhaust-gas temperatures. All temperatures were measured on potentiometers calibrated to read in degrees Fahrenheit.

Total pressures at stations 1 and 3 were measured with impact-tube rakes and all pressure measurements indicated on an 84-inch manometer board, which was photographed in order to obtain instantaneous readings.

All temperature- and pressure-measuring instruments were located at centers of equal areas; exact locations are shown in figure 4.

Combustor

The combustor was a reproduction of a one-sixth segment of the complete combustor annulus of the 19B (or 19XB) engine. The combustor segment was built to the exact dimensions of the engine combustor with the exception of the internal air baffles. These baffles are thin metal sheets separating the combustion-zone annulus from the inlet-air annuli. The distribution of air to the combustion zone is controlled by the arrangement of holes in the baffles through which the air passes. In the combustor segment, these internal air baffles were made 1/16 inch thick instead of 1/32 inch thick to give added strength under the imposed conditions. The internal air baffle is hereinafter referred to as "the basket". Developments of the outer and the inner walls of the basket in the segment are shown in figure 5(a). The hole arrangement is that of the original design. Figures 5(b) to 5(g) show developments of the basket with the hole arrangements for modifications 1 to 6. Modifications 1 to 4 consisted in blocking holes in the basket of the original design. Such modifications not only changed the hole arrangement but by decreasing the hole area in the basket increased the total-pressure drop through the combustor segment. In order to separate the effect on combustor performance of changes in axial-air distribution and the effect of increasing the total-pressure drop through the combustor, combustor modifications 5 and 6 were designed and investigated. Combustor modification 5 has the hole arrangement of the original basket but the hole area in the basket is proportionately decreased to give a pressure drop equal to that of modification 4. Modification 6 has the same hole arrangement as modification 4 but the hole area is proportionately increased to yield the total-pressure drop of the original basket. Modification 7 (fig. 6) consisted of the insertion of baffle plates at the position shown in order to force more air into the upstream end of the basket.

The fuel-atomizing nozzles used in the combustor segment had a capacity of $10\frac{1}{2}$ gallons, spray angle of 60° , were of the hollow-cone spray type, and were chosen from a group of calibrated nozzles. The four nozzles chosen had a maximum individual variation in flow of 2.0 percent from the average flow of the four nozzles.

PROCEDURE

The altitude operational limits were determined for each configuration of the combustor segment. For any given engine speed, the limiting altitude was considered as the altitude at which either the temperature rise through the combustor was insufficient to operate the engine, or at which the temperature rise was sufficient but operation became so unstable that blow-outs often occurred. During unstable operation, some flickering was always present; the flickering varied in intensity, depending on the altitude, from a dimming and brightening of the flame to actual intermittent combustion. The frequency of the flicker varied from a rapid, barely discernible value accompanying the dimming and brightening of the flame to a frequency of a few seconds that accompanied the intermittent combustion. This instability became progressively more severe as the altitude was increased at any engine speed until the on-off flicker finally resulted in blow-out. In the case of unstable combustion with temperature rise sufficient for engine operation, the limiting altitude could not be clearly defined and was considered to be indeterminate from investigations on the combustor segment. A possibility exists that the engine combustor operation under the same inlet conditions as the combustor segment would operate more stably because the larger number of fuel nozzles should allow reignition of any locally blown-out regions of the engine combustor from the adjacent burning regions.

In order to measure the effect of basket modification on temperature-rise efficiency through the combustor segment, temperature rise was observed for a range of fuel-air ratios at constant inlet-air conditions. The following conditions chosen for these investigations were for the 19B engine: (1) high engine power: altitude, sea level; engine speed, 17,000 rpm; (2) low altitude condition through which the engine might be required to accelerate: altitude, 5000 feet; engine speed, 12,000 rpm; (3) altitude, 16,600 feet; engine speed, 10,000 rpm; with an excess of 20 percent of the combustor-inlet total pressure that the compressor would normally supply, and (4) altitude, 30,000 feet; engine speed, approximately 16,500 rpm. Conditions 3 and 4 were used for several of the engine combustor investigations (reference 2) that have

proceeded in parallel with this investigation. Conditions 3 and 4, which were used for several of the combustor investigations, do not necessarily represent any engine operating condition but were selected in order to compare the performance of the combustor segment and the performance of the entire combustor. Pressure loss through the combustor was measured at conditions 3 and 4 because pressure data could be taken simply while running temperature-rise efficiency determinations. Similar determinations were made at several altitude and engine-speed conditions for the 19XB engine. These investigations furnished additional pressure-loss data.

RESULTS AND DISCUSSION

Axial Redistribution of Air

The effect that hole modification has on axial-air distribution is graphically shown in figure 7. Each combustor-basket modification can be identified by the basket strip at the top of the figure. The stepped curve in the top half of the figure gives the hole area from the upstream end of the basket to any given point, which quantity will be hereinafter designated incremental basket-hole area, expressed as a percentage of the total basket-hole area. In the lower half of the figure, calculated axial-air velocities in the combustion zone annulus are shown, for the nonburning case of the same modification, as fractions of the combustor-inlet velocity measured at station 1. In figure 7, the calculated velocity is appropriately designated area ratio. Because the ratio of the inlet area to the maximum area inside the combustion zone is 0.485, the velocity at the maximum cross section in the combustion zone calculated in this manner is 0.485 times the inlet-air velocity. These values are not to be considered as actual velocities during combustion because during combustion the large change in pressure distribution caused by the momentum-pressure loss associated with burning causes an appreciable change in the air flow through the basket holes.

For the original combustor-basket design, figure 7 also shows the incremental basket-hole area gradually increasing along the entire length of the basket. The basket-hole area is as shown for other modifications. No more than 20 percent of the total amount of air was allowed to enter the combustion zone along the first half of the basket for modifications 4 and 6.

The effects of basket-hole arrangement on the altitude operational limits and temperature-rise efficiency are shown in figures 8(a) and 9, respectively, and will be subsequently discussed in detail.

Total-Pressure Loss

In order to make comparisons with the total-pressure loss of other turbojet combustors, the total-pressure loss through the combustor segment is expressed as $\Delta P/q_r$, where ΔP is the actual total-pressure loss in inches of mercury and q_r is the dynamic pressure that would exist at the inlet section if, at that section, use were made of the maximum cross-sectional area of the unit. This method of comparison attributes the poor inlet-diffuser design to the combustor and does not penalize a combustor designed for a low-inlet dynamic pressure. Pressure losses are shown as a function of the inlet-to-outlet density ratio ρ_1/ρ_2 for the original combustor basket and for modifications 1 to 4 in figure 10(a). Similarly, the pressure losses for the original combustor design and for modifications 4, 5, and 6 are presented in figure 10(b). At an inlet-to-outlet density ratio of 2.4, the total-pressure loss of the original combustor-basket design is $14q_r$, approximately $15q_r$ for modification 6, and approximately $19q_r$ for modifications 4 and 5 (fig. 10(b)).

A discussion of these data is postponed to the following sections of the report where their appearance is most logical and the significance of the effect of pressure loss on combustor performance can be most clearly indicated.

Altitude Operational Limits

A comparison between altitude operational limits of the combustor for the various modifications is given by figure 8. For each modification it was necessary to run from 10 to 18 test points in the manner previously described for determining altitude operational limits.

For the combustor segment of the original combustor-basket design and for 19B inlet conditions, at a simulated engine speed of 9500 rpm, operation was unsatisfactory at altitudes above 13,000 feet (fig. 8(a)). After the first modification of the combustor segment, the operating range was increased up to the limits shown by the curve marked modification 1. The operational limits for modifications 2, 3, and 4 are similarly indicated in figure 8(a). Altitude operational limits for the original design obtained from runs on the complete annular combustor are included in figure 8(a) for comparison, and checked reasonably well with those obtained from the runs on the combustor segment. The altitude performance

of modification 4 is the best of the modifications because an engine operating with this combustor would have the greatest range of altitude operation.

When the air distribution was changed by blocking the holes, the method followed in making modifications 1 to 4 considerably increased the total-pressure loss as shown in figure 10(a). Modification 4, which has the best performance characteristics, has the highest pressure loss. This relation might seem to indicate that a high total-pressure loss is necessary for satisfactory combustor performance. In figure 8(b), the altitude operational limits for modification 5 (high-pressure loss, fig. 10(b)), at the low engine speeds (10,000 rpm) are slightly lower than those of the original design (23,000 ft as compared with 26,000 ft for the original design at the same engine speed of the 19XB engine) although the air distribution for modification 5 is essentially that of the original design. At engine speeds above 70 to 75 percent of the normal rated engine speed of 17,500 rpm, the altitude operational limits of modification 5 are higher than those obtained with the original combustor design (above 52,000 ft at 17,000 rpm as compared with 38,000 ft for the original combustor at the same engine speed of the 19XB engine). In figure 8(c), the comparison is made between modification 6 (air distribution of modification 4, total-pressure loss equal to that of the original design) and modification 4, the basket-hole modification in the blocked-hole series giving the maximum altitude operating range. With this modified air distribution, modification 6 (low pressure loss, fig. 10(b)) had altitude operational limits consistently higher than those of modification 4.

In the comparisons previously made, pressure loss has been shown to affect the altitude performance of the combustor for similar hole-area arrangements in the basket.

By comparison of the two modifications that have the same total-pressure loss but different hole arrangements, the effect of air-distribution change alone can be seen. In figure 8(d), the effect of air distribution alone is illustrated by comparing the altitude operational limits of modification 5 with those of modification 4. In this case, the total-pressure loss for both modifications is very closely the same but the hole arrangement for modification 5 is that of the original design and the hole arrangement for modification 4 is as shown in figures 5(e) and 7(e). The altitude performance of modification 4 is higher than that of modification 5 over most of the range of engine operation. At rated speed, however, for 19XB engine combustor-inlet conditions modification 5 slightly outperforms 4. A comparison is again made for

two combustor configurations having the same total-pressure loss and different hole arrangements in figure 8(e). In this case, the total-pressure loss is much less than for the combustors compared previously. Modification 6 (modified hole arrangement) is compared with the original design. The altitude operational limits of modification 6 are 50,000 feet at 17,000 rpm and 38,000 feet at 10,000 rpm for the 19XB engine. These limits are notably higher than those of the original combustor over the range of engine speeds investigated.

Operation of the combustor segment with modification 7 was so inefficient it was evident that any modification by which more air was introduced in this manner through the upstream end of the basket was definitely detrimental to the operation of the combustor segment. The results of the investigation with modification 7 are not shown.

Temperature-Rise Efficiencies

The variation of temperature rise with fuel-air ratio for the various combustor modifications for 19B engine combustor-inlet conditions is shown in figure 9. Lines of constant temperature-rise efficiency are included for reference. In every modification but two, the temperature-rise efficiency is constant over the range of fuel-air ratios, with a slight decrease in efficiency occurring at the higher values of fuel-air ratio. For comparison, the results of runs for the entire annular 19B engine combustor of the original design (reference 2) are included in figures 9(c) and 9(d). From this comparison the results obtained from an experimental investigation of temperature rise in a one-sixth combustor segment can apparently be used only to compare the relative temperature-rise efficiencies of various combustor designs in the segment because satisfactory check with the complete annulus was not obtained, which was probably due in part to the effect of the walls in the segment not present in the complete annulus. For the conditions given in figure 9(a), only modification 4 was investigated because knowledge of the performance of this modification at sea-level take-off conditions was desirable. With respect to efficiency, the curves for the various modifications fall with consistent relation to each other for the three sets of inlet conditions in figures 9(b), 9(c), and 9(d). It is to be recalled here that with respect to altitude performance, modification 6 outperformed all other modifications. The fact that modification 4 showed the highest temperature-rise efficiencies over the range of conditions investigated seems to indicate that in the combustor segment there is no consistent correlation between temperature-rise efficiency

and altitude operational limits. This inconsistency can be explained if it is remembered that many of the altitude experimental points were inoperative because of sudden blow-out and not because of a decrease in temperature-rise efficiency. The efficiency of modification 4 at the required outlet temperature at sea level and an engine speed of 17,000 rpm for the 19B engine was 97 percent. For this modification at 30,000 feet and 16,500 rpm for the 19B engine the efficiency was 92 percent. Temperature-rise efficiencies for modification 6 are higher than those for modification 5 over the larger part of the range of fuel-air ratios covered by the investigations; whereas, the temperature-rise efficiencies of modification 5 are slightly higher than the original design.

In two of the curves (figs. 9(b) and 9(c)), an extreme drop in temperature-rise efficiency occurs at an intermediate fuel-air ratio and then the curves continue again at constant efficiency. This drop might indicate a shift in flame seat or a change in type of combustion.

Temperature Distribution at Combustor Outlet

The temperature patterns at the combustor outlet are shown by means of contour diagrams in figure 11. The condition for which all the contour diagrams are shown is for the 19B engine at an altitude of 5000 feet and an engine speed of 12,000 rpm. Figure 11(a) shows the temperature pattern for the original combustor design. A high-temperature region exists at the left of the figure and from there to the opposite side of the outlet section the temperatures gradually decrease. This distribution persisted throughout the investigations for all the modifications and the variation in temperature appeared somewhat more extreme for several of the modified combustors. Peak temperatures for some at the modifications were as much as 200° F higher than in the original design for approximately the same average combustor-outlet temperature (930° F).

A temperature check made 13 inches downstream of the combustor-outlet section showed no appreciable increase in temperature or afterburning downstream of what would be the turbine-inlet section (station 2) in the actual engine (fig. 12).

SUMMARY OF RESULTS

Results of an experimental investigation to determine the effect of air-flow distribution and total-pressure loss on performance of a one-sixth combustor segment of the annular-combustor type are as follows:

1. Altitude operational limits of the combustor segment, for the 19XB engine using the original combustor-basket design were approximately 38,000 feet at 17,000 rpm, and 26,000 feet at 10,000 rpm. The altitude operational limits were approximately 50,000 feet at 17,000 rpm and 38,000 feet at 10,000 rpm for a combustor-basket design in which the air-passage area in the basket was redistributed so as to admit gradually no more than 20 percent of the air along the first half of the basket. In this case the total-pressure loss through the combustor segment was not appreciably changed from the total-pressure loss for the original combustor-basket design.

2. Altitude operational limits of the combustor segment for the 19XB engine were above 52,000 feet at 17,000 rpm and were approximately 23,000 feet at 10,000 rpm for a combustor-basket design in which the distribution of the air-passage area in the basket was that of the original design but where the total-pressure loss was increased to 19 times the inlet reference kinetic pressure at an inlet-to-outlet density ratio of 2.4. The total-pressure loss for the original design was 14 times the inlet kinetic reference pressure at an inlet-to-outlet density ratio of 2.4.

3. Trends in the results from investigations of the altitude stability for the 19B engine were similar to those obtained for the 19XB engine.

4. For the four operating conditions of altitude and engine speed at which temperature-rise efficiencies were investigated for the 19B engine, the combustor-basket design in which the air-passage area in the basket was redistributed to allow 20 percent of the air to enter in the first half of the basket and where the total-pressure loss was increased above that for the original combustor design, consistently showed the highest temperature-rise efficiency. A temperature-rise efficiency of 97 percent was obtained for this design at sea level and 17,000 rpm. The efficiency was 92 percent for this design at 30,000 feet and 16,500 rpm.

5. Temperature distribution at the combustor outlet was affected by design changes which caused changes in air distribution

or total-pressure loss. For the same average combustor-outlet temperature of 930° F, peak temperatures were as much as 200° F higher for some modifications than for the original combustor.

Flight Propulsion Research Laboratory,
National Advisory Committee for Aeronautics,
Cleveland, Ohio.

Francis U. Hill, Jr.,
Mechanical Engineer.

Herman Mark,
Mechanical Engineer.

Approved:

Walter T. Olson,
Chemist.

Benjamin Pinkel,
Physicist.

rl

REFERENCES

1. Fleming, William A.: Altitude-Wind-Tunnel Investigation of the Westinghouse 19B-2, 19B-8, and 19XB-1 Jet-Propulsion Engines. I - Operational Characteristics. NACA MR No. E6E06, Bur. Aero., 1946.
2. Childs, J. Howard, McCafferty, Richard J., and Surine, Oakley W.: Effect of Combustor-Inlet Conditions on Performance of an Annular Turbojet Combustor. NACA TN No. 1357, 1947.

INDEX OF FIGURES

- Figure 1. - Operating characteristics of two turbojet engines at flight speed of 0 miles per hour. (Reference 1.)
(a) 19B turbojet engine.
(b) 19XB turbojet engine (estimated data).
- Figure 2. - Diagram of laboratory ducting and installation of one-sixth combustor segment.
- Figure 3. - Diagram of one-sixth combustor segment showing location of instruments and details of ducting.
- Figure 4. - Instrumentation arrangement of thermocouples and total-pressure rakes.
(a) Inlet thermocouples, upstream of station 1.
(b) Thermocouple rakes at station 2.
(c) Inlet total-pressure rakes, downstream of station 1.
(d) Thermocouple rakes and total-pressure rakes at station 3.
- Figure 5. - Development of basket walls of one-sixth combustor segment.
(a) Original design.
(b) Modification 1 (shaded holes blocked).
(c) Modification 2 (shaded holes blocked).
(d) Modification 3 (shaded holes blocked).
(e) Modification 4 (shaded holes blocked).
(f) Modification 5.
(g) Modification 6.
- Figure 6. - Cross section of one-sixth combustor segment with modification 7. Basket-hole arrangement as originally designed.
- Figure 7. - Axial distribution of hole area in basket and area-ratio representation of relative air velocities in combustion zone for nonburning conditions.
(a) Original design.
(b) Modification 1.
(c) Modification 2.
(d) Modification 3.
(e) Modification 4.
(f) Modification 5.
(g) Modification 6.

Figure 8. - Altitude operational limits of one-sixth segment of annular turbojet combustor.

- (a) Effect of basket-hole modifications. Investigation conducted using 19B engine performance characteristics.
- (b) Effect of changes in total-pressure loss through basket. Original air distribution.
- (c) Effect of changes in total-pressure loss through basket. Modified air distribution.
- (d) Effect of air-flow distribution through basket. High combustor total-pressure loss.
- (e) Effect of air-flow distribution through basket. Low combustor total-pressure loss.

Figure 9. - Effect of fuel-air-ratio variation on temperature rise through combustor.

- (a) Operating conditions for 19B engine at sea level and engine speed of 17,000 rpm: air flow, 4.85 pounds per second; inlet-air total pressure, 42.8 pounds per square inch absolute; inlet-air temperature, 300° F.
- (b) Operating conditions for 19B engine at altitude of 5000 feet and engine speed of 12,000 rpm: air flow, 2.77 pounds per second; inlet-air total pressure, 23.0 pounds per square inch absolute; inlet-air temperature, 155° F.
- (c) Operating conditions for 19B engine at altitude of 16,000 feet and engine speed of 10,000 rpm with 20-percent excess of normal inlet total pressure: air flow, 1.91 pounds per second; inlet-air total pressure, 16.1 pounds per square inch absolute; inlet-air temperature, 80° F.
- (d) Operating conditions for 19B engine at altitude of 30,000 feet and engine speed of 16,500 rpm: air flow, 1.87 pounds per second; inlet-air total pressure, 16.0 pounds per square inch absolute; inlet-air temperature, 190° F.

Figure 10. - Total-pressure loss through combustor segment shown as function of inlet-to-outlet density ratio.

- (a) Comparison of original design and modifications 1, 2, 3, and 4.
- (b) Comparison of original design and modifications 4, 5, and 6.

Figure 11. - Combustor-outlet cross section showing temperature pattern of gases entering turbine. Altitude, 5000 feet; engine speed, 12,000 rpm; required combustor-outlet temperature, 930° F; 19B engine. All temperatures are given in °F.

- (a) Original design. Average combustor-outlet temperature, 970° F.
- (b) Modification 1. Average combustor-outlet temperature, 952° F.
- (c) Modification 2. Average combustor-outlet temperature, 960° F.
- (d) Modification 3. Average combustor-outlet temperature, 953° F.
- (e) Modification 4. Average combustor-outlet temperature, 969° F.
- (f) Modification 5. Average combustor-outlet temperature, 924° F.
- (g) Modification 6. Average combustor-outlet temperature, 984° F.

Figure 12. - Comparison of thermocouple rake average at station 2 with thermocouple rake average at station 3.

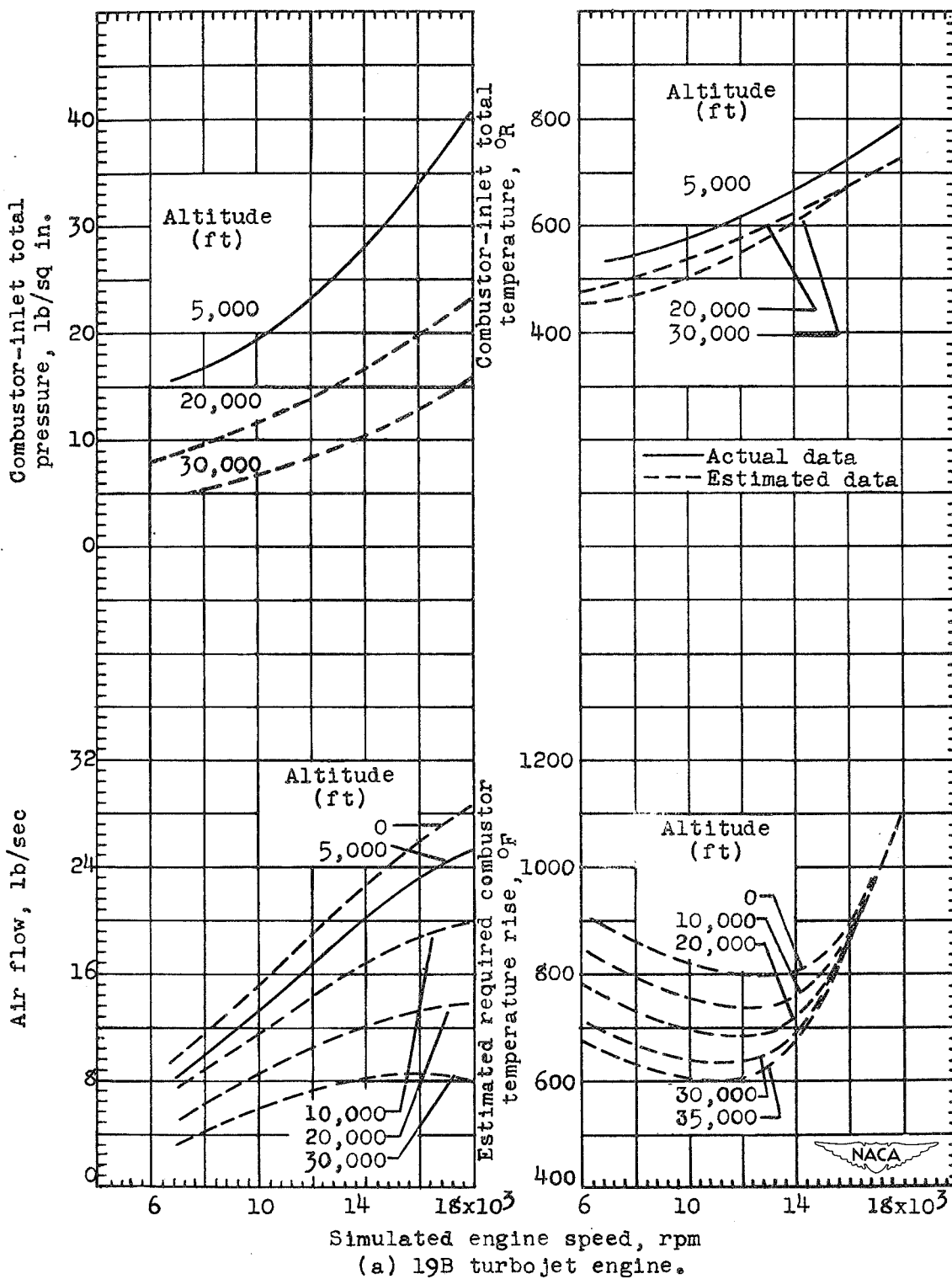

Figure 1. - Operating characteristics of two turbojet engines at flight speed of 0 mile per hour. (Reference 1.)

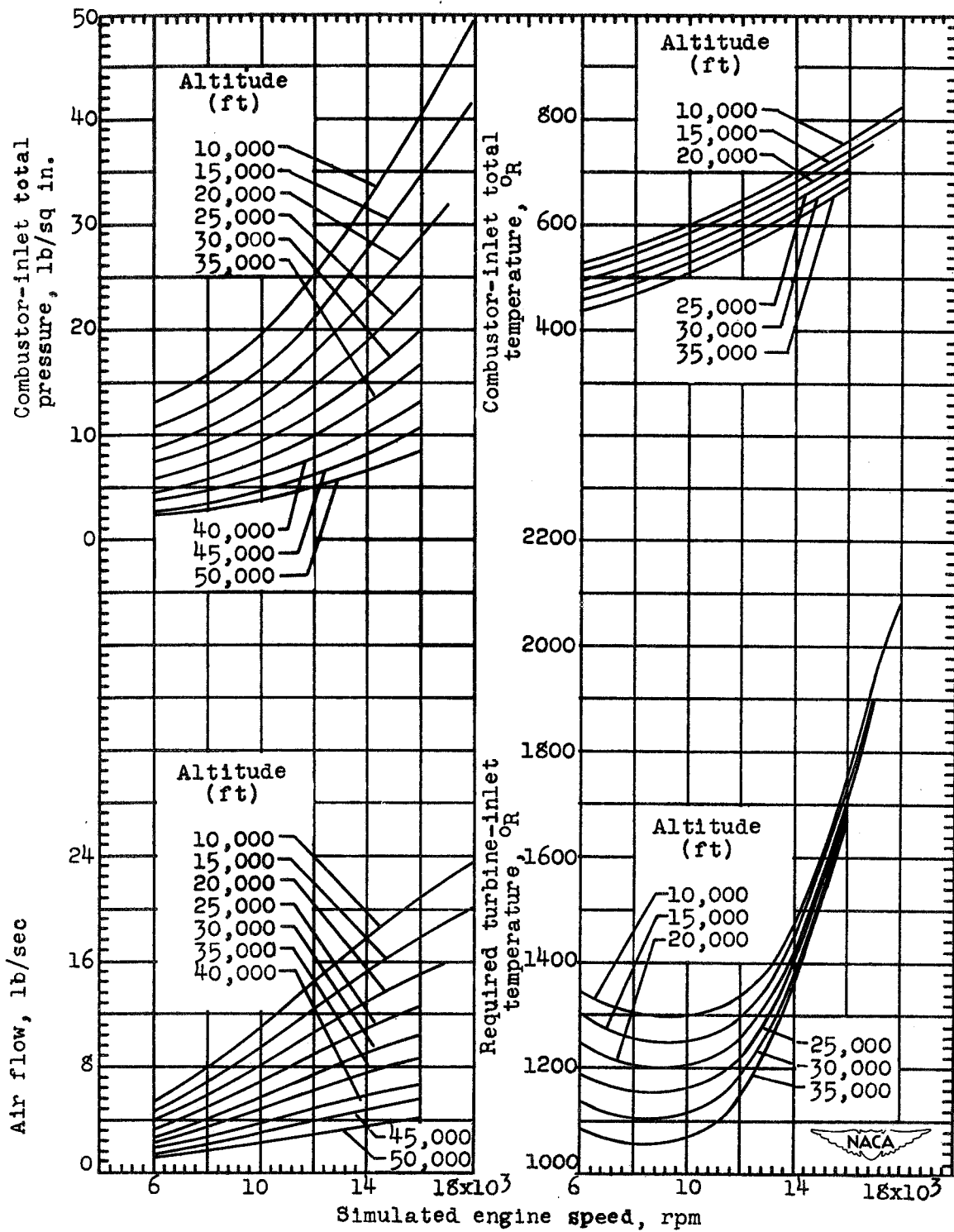
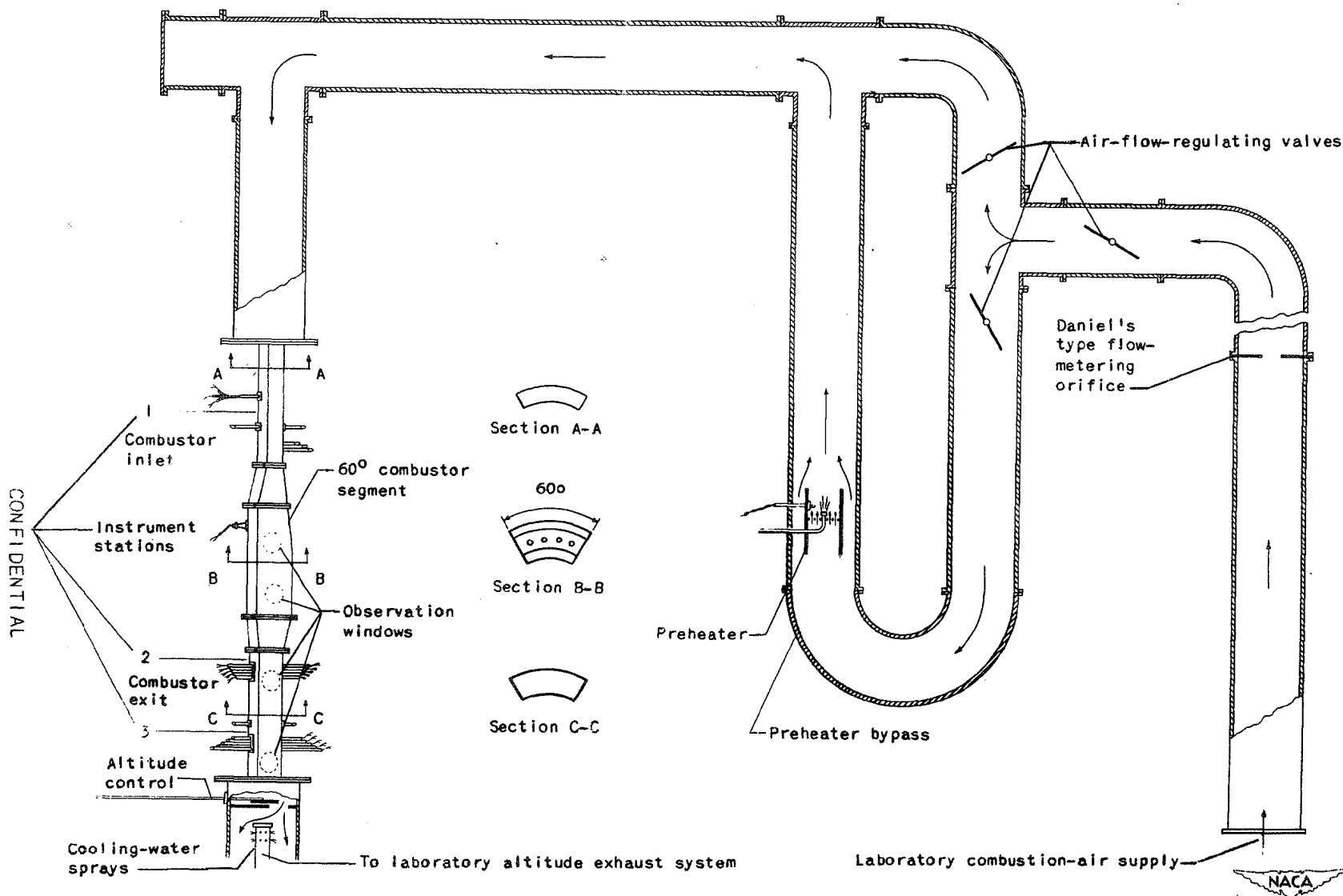

Figure 1. - Concluded. Operating characteristics of two turbojet engines at flight speed of 0 mile per hour. (Reference 1.)



CONFIDENTIAL

Figure 2. - Diagram of laboratory ducting and installation of one-sixth combustor segment.

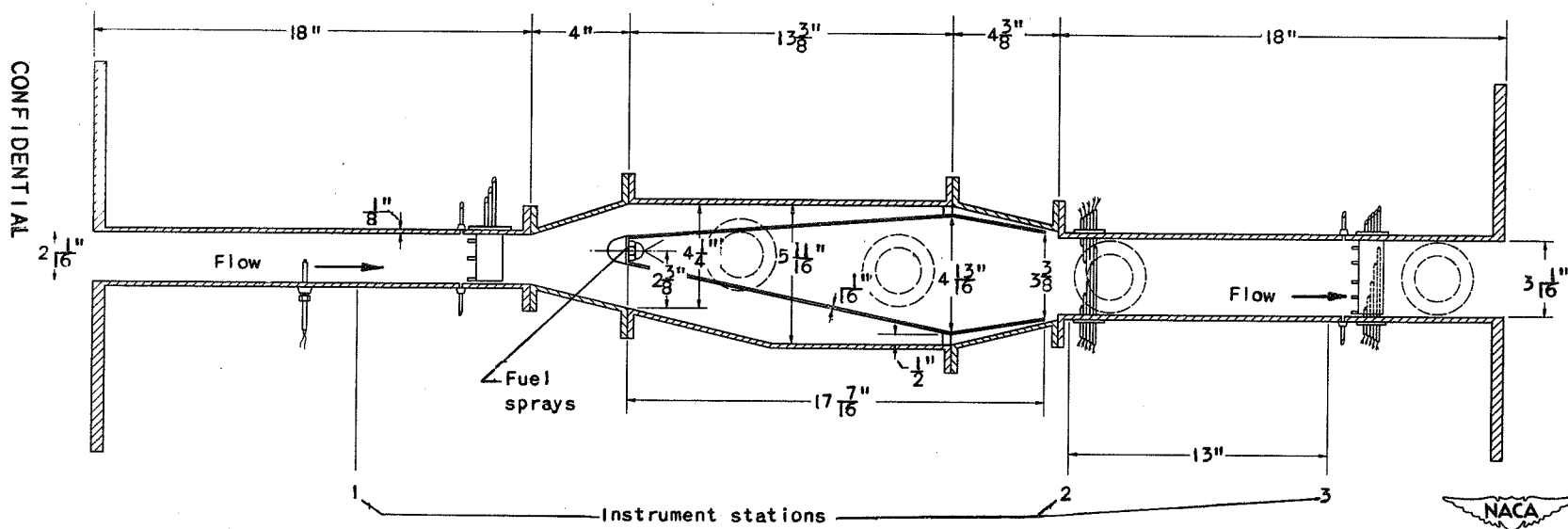
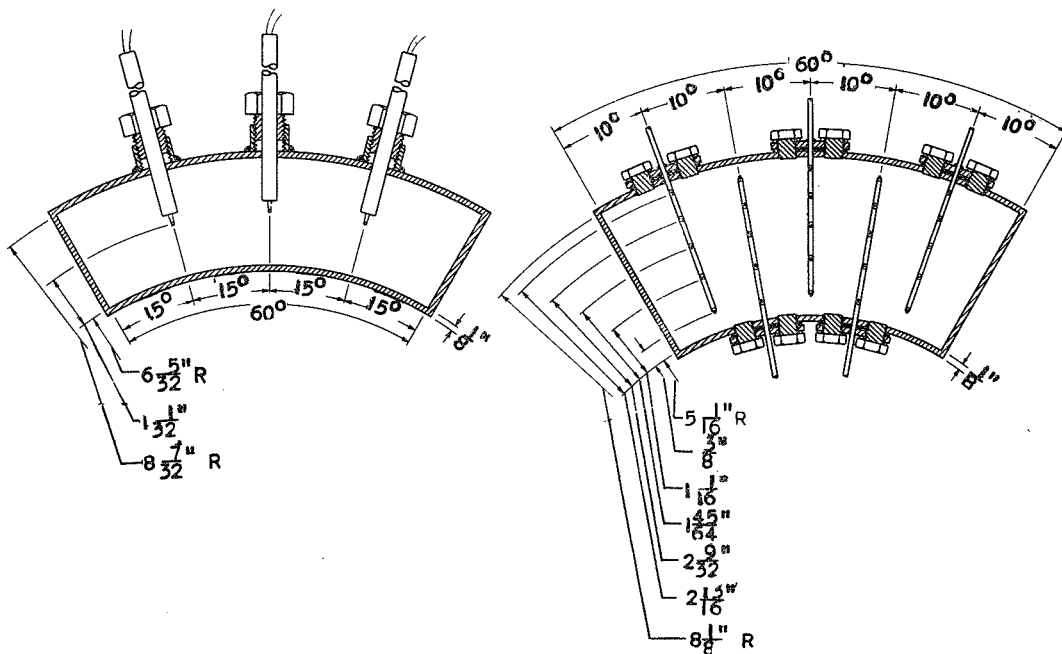
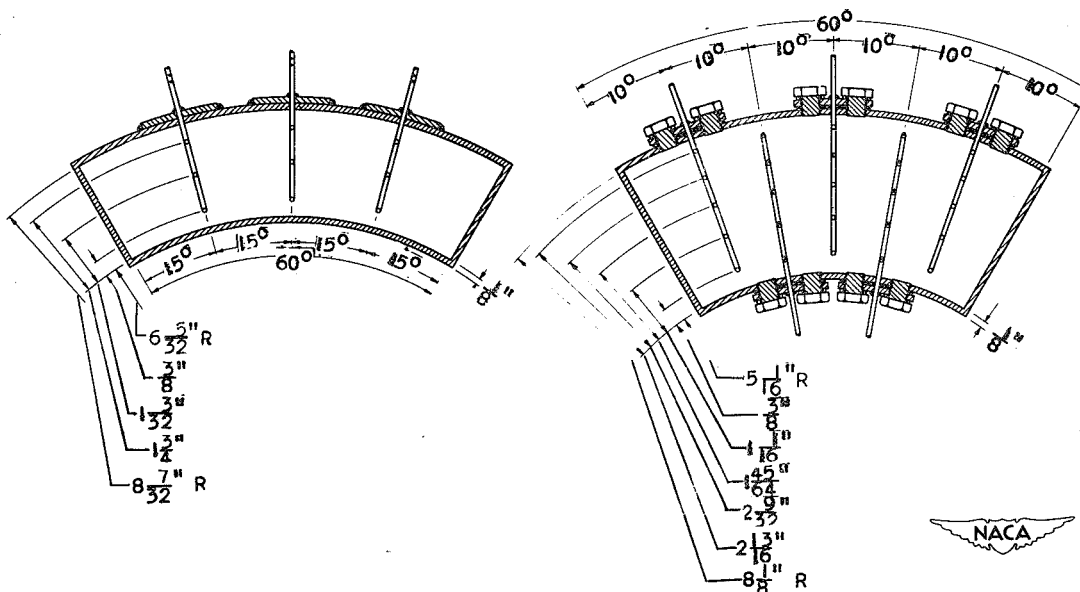

Figure 3. - Diagram of one-sixth combustor segment showing location of instruments and details of ducting.



(a) Inlet thermocouples, upstream at station 1.

(b) Thermocouple rakes at station 2.



(c) Inlet total-pressure rakes, downstream at station 1.

(d) Thermocouple rakes and total-pressure rakes at station 3.



Figure 4. - Instrumentation arrangement of thermocouples and total-pressure rakes.

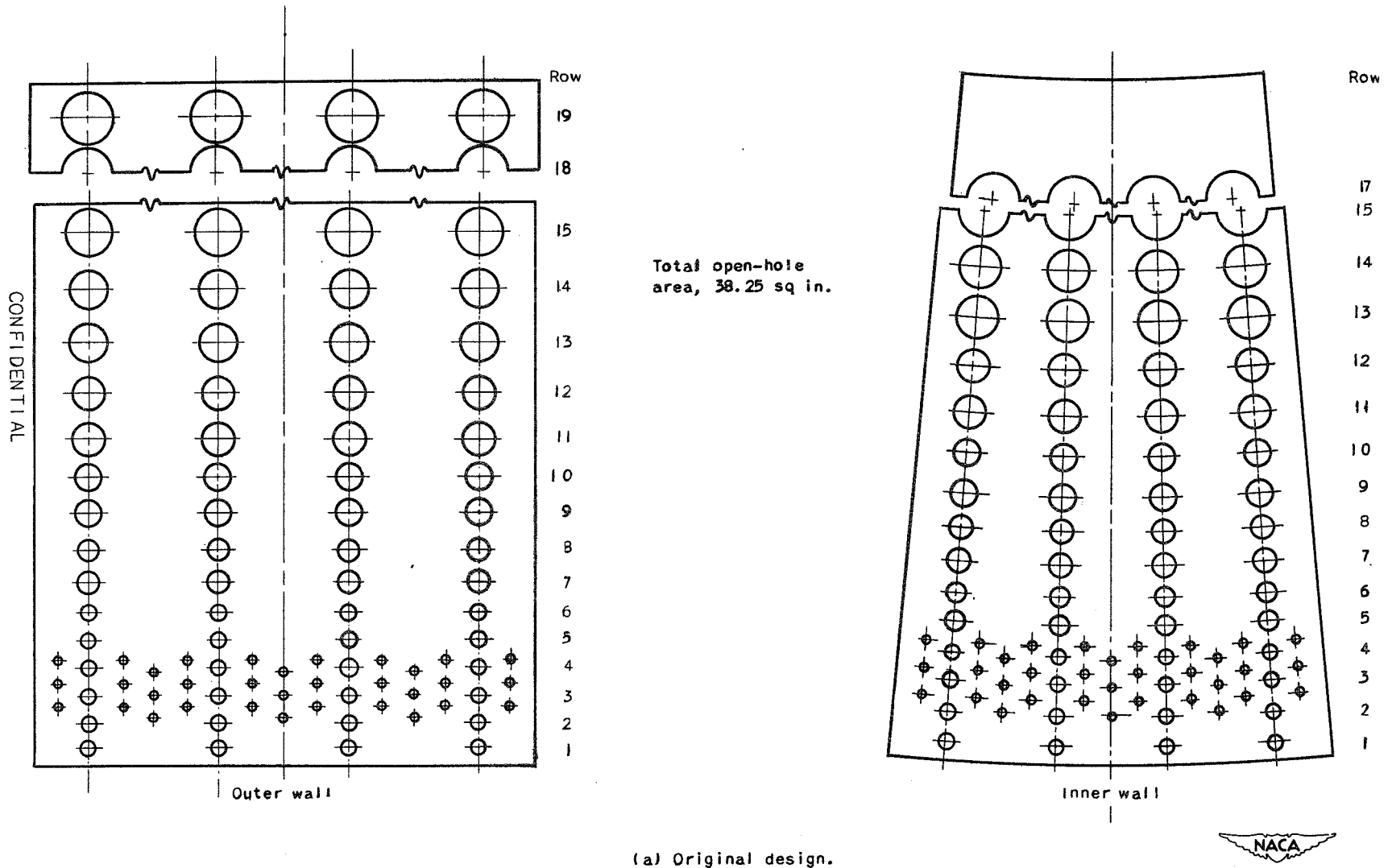

Figure 5. - Development of basket walls of one-sixth combustor segment.

Row

Row

19

18

15

14

13

12

11

10

9

8

7

6

5

4

3

2

1

Outer wall

Row

17

15

14

13

12

11

10

9

8

7

6

5

4

3

2

1

Inner wall



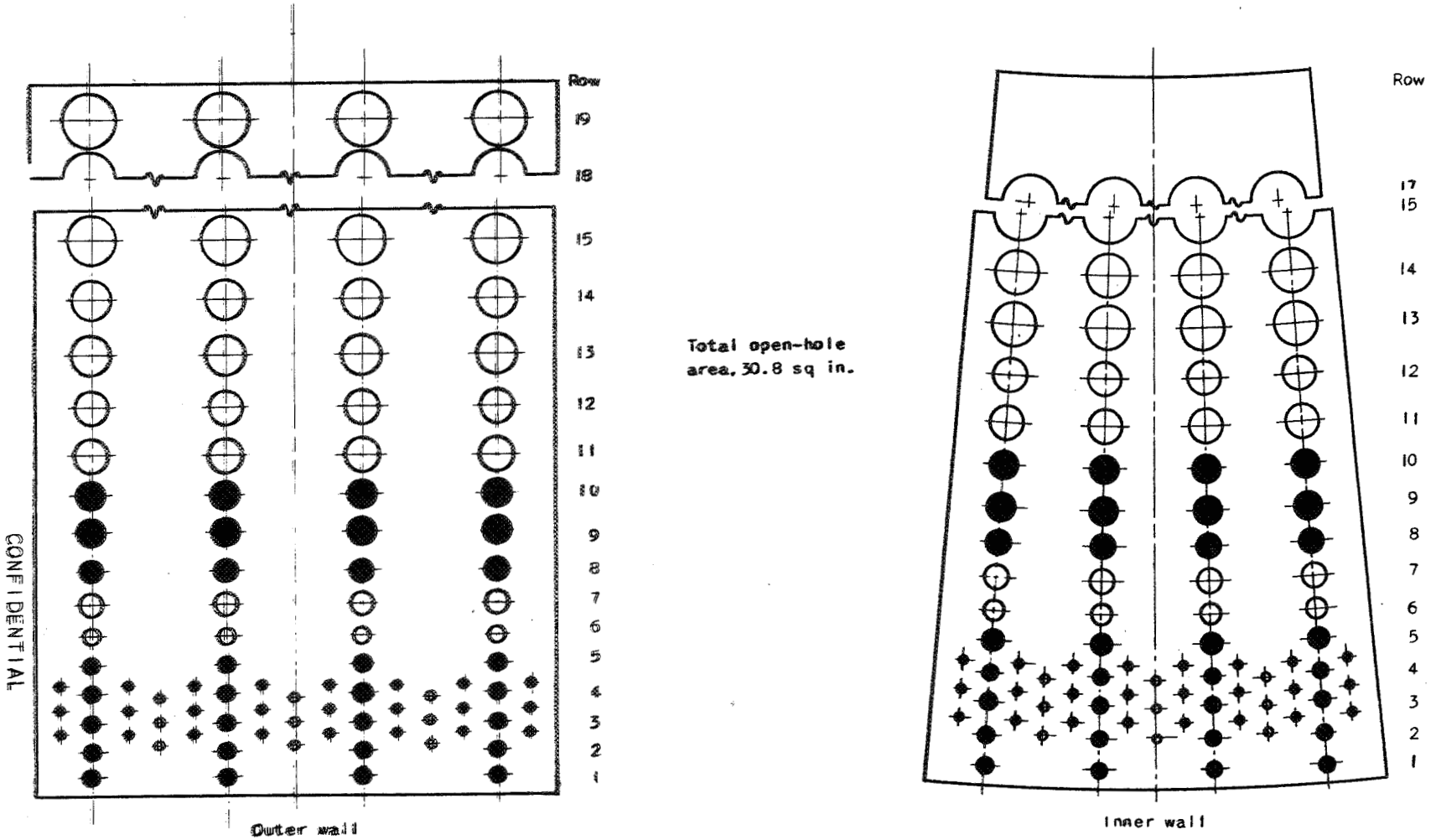

(b) Modification I (shaded holes blocked).

Figure 5. - Continued. Development of basket walls of one-sixth combustor segment.

CONFIDENTIAL

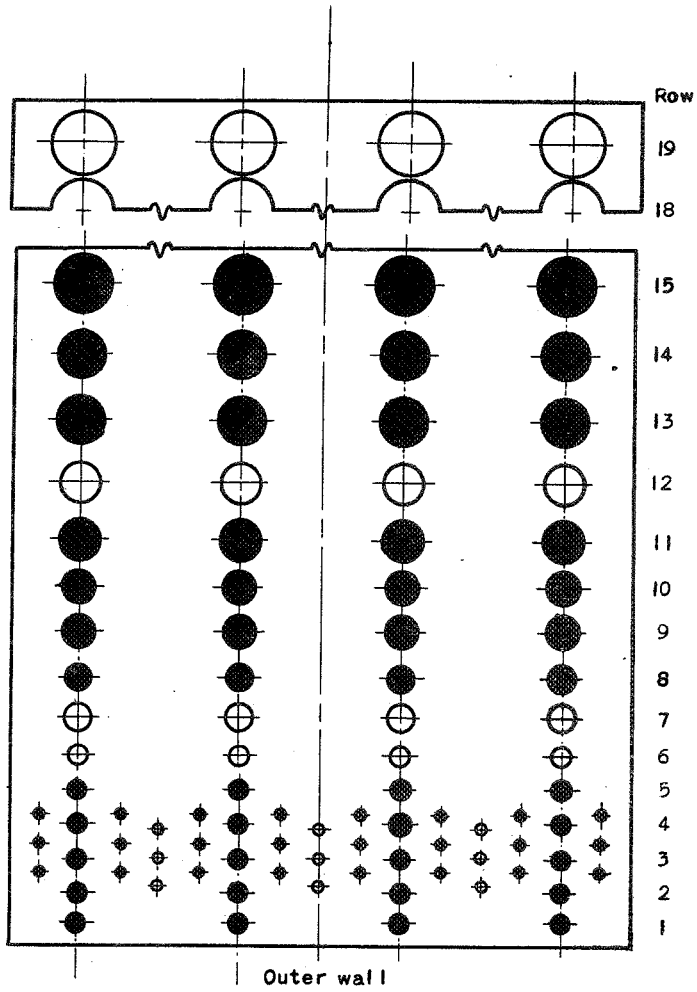

Total open-hole
area, 20.31 sq in.

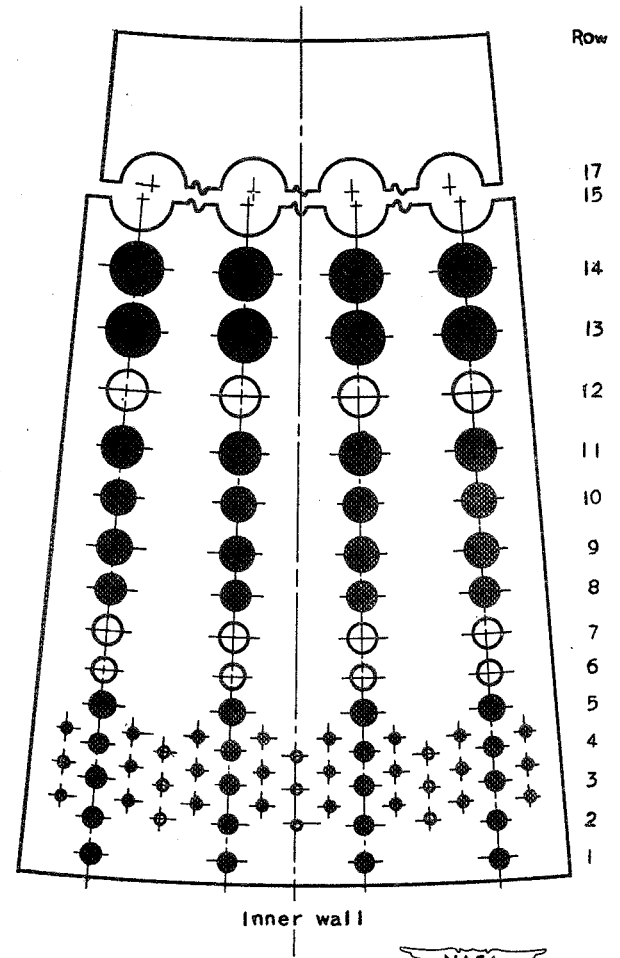

(c) Modification 2 (shaded holes blocked).

Figure 5. - Continued. Development of basket walls of one-sixth combustor segment.



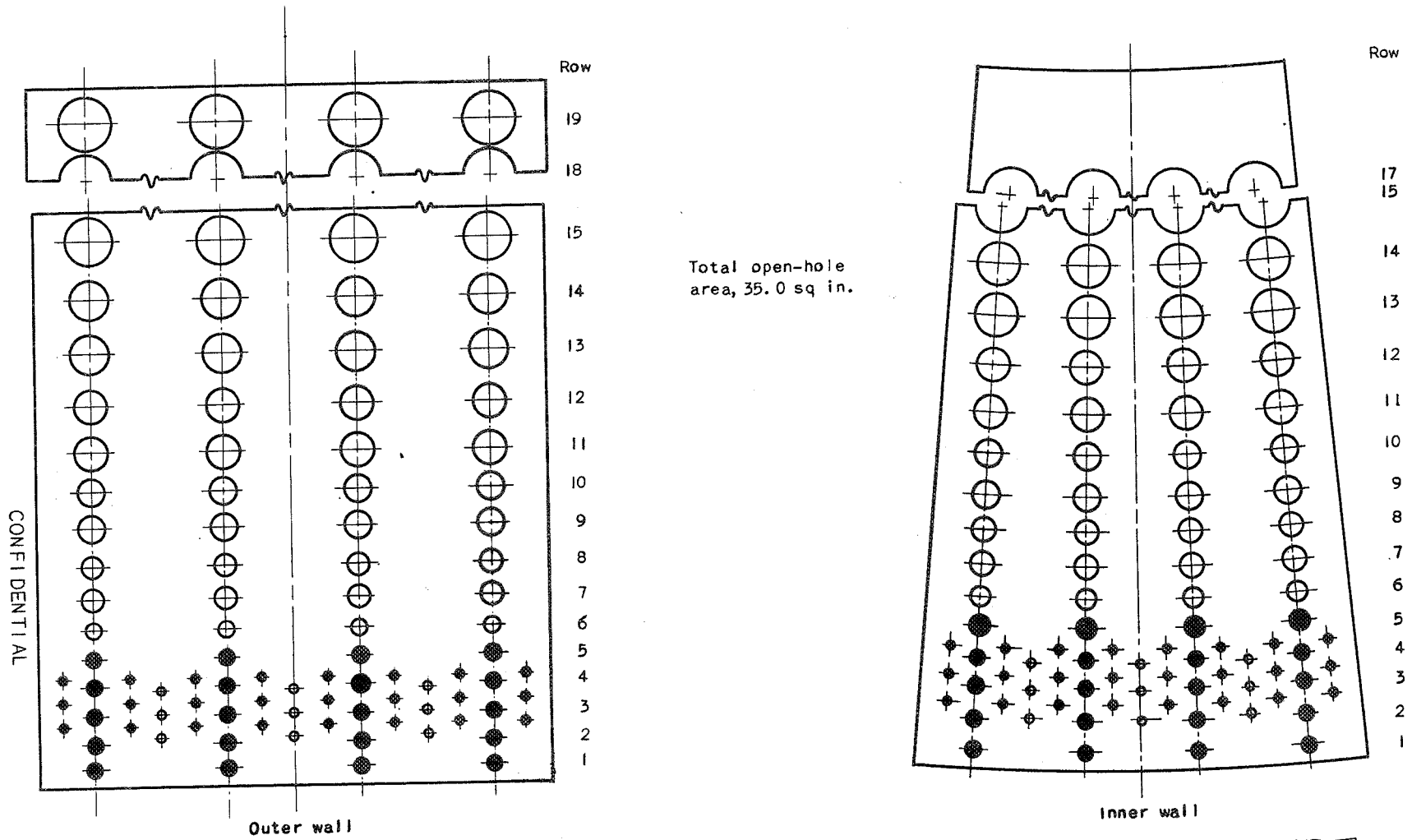

(d) Modification 3 (shaded holes blocked).



Figure 5. - Continued. Development of basket walls of one-sixth combustor segment.

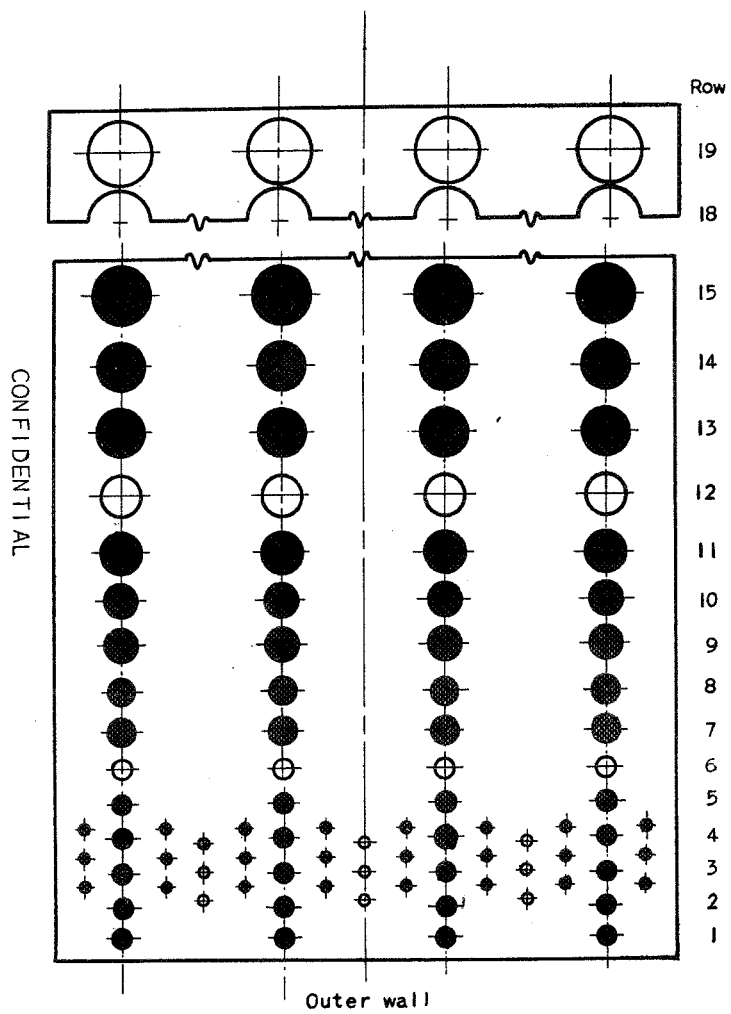

Total open-hole area, 19.27 sq in.

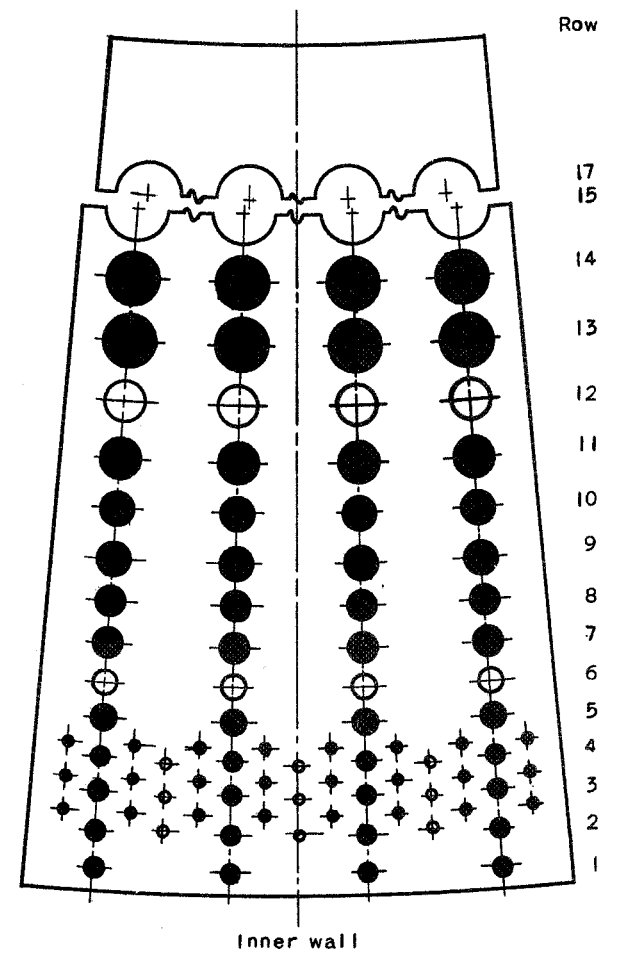

(e) Modification 4 (shaded holes blocked).



Figure 5. - Continued. Development of basket walls of one-sixth combustor segment.

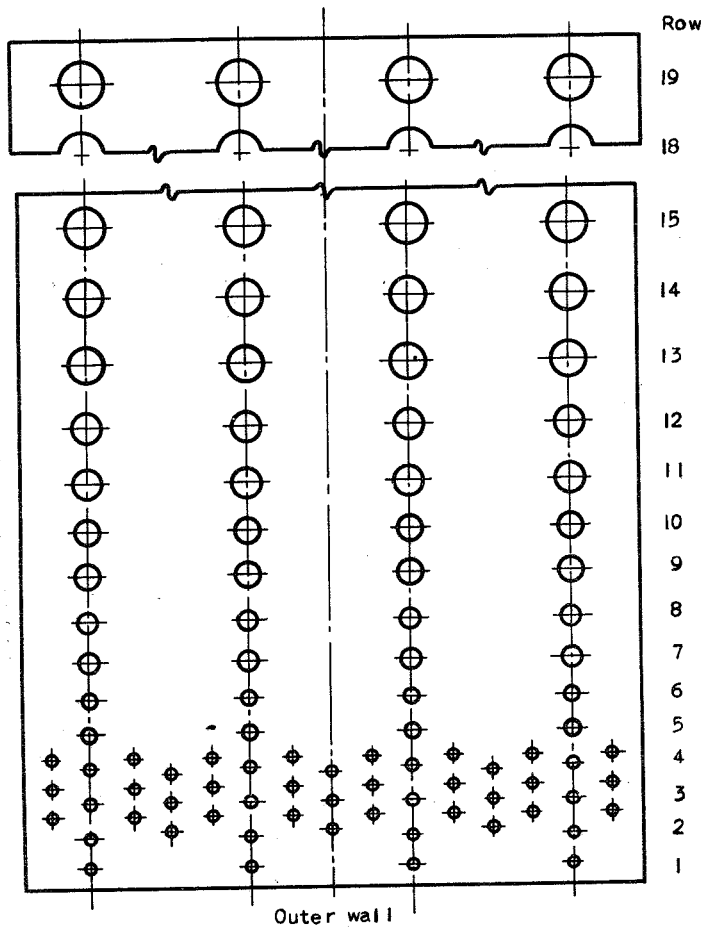

Total open-hole
area, 20.19 sq in.

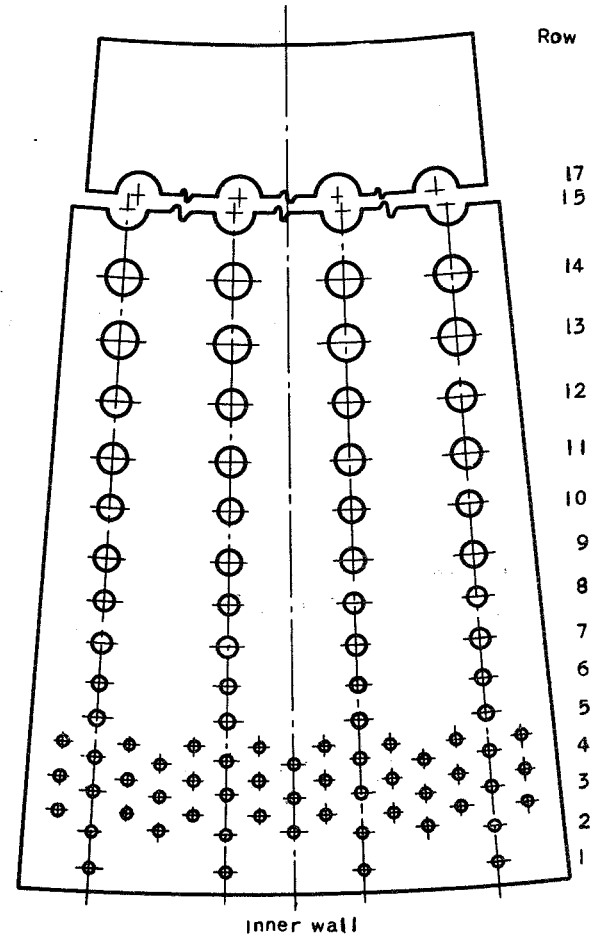

(f) Modification 5.



Figure 5. - Continued. Development of basket walls of one-sixth combustor segment.

CONFIDENTIAL

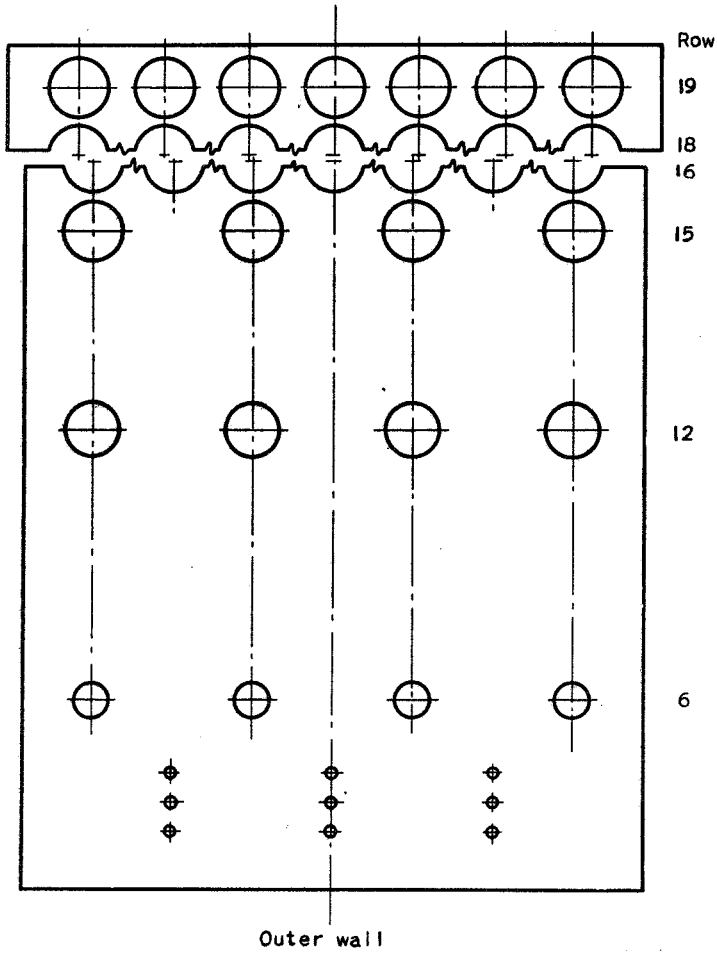

Total open-hole
area, 37.33 sq in.

(g) Modification 6.

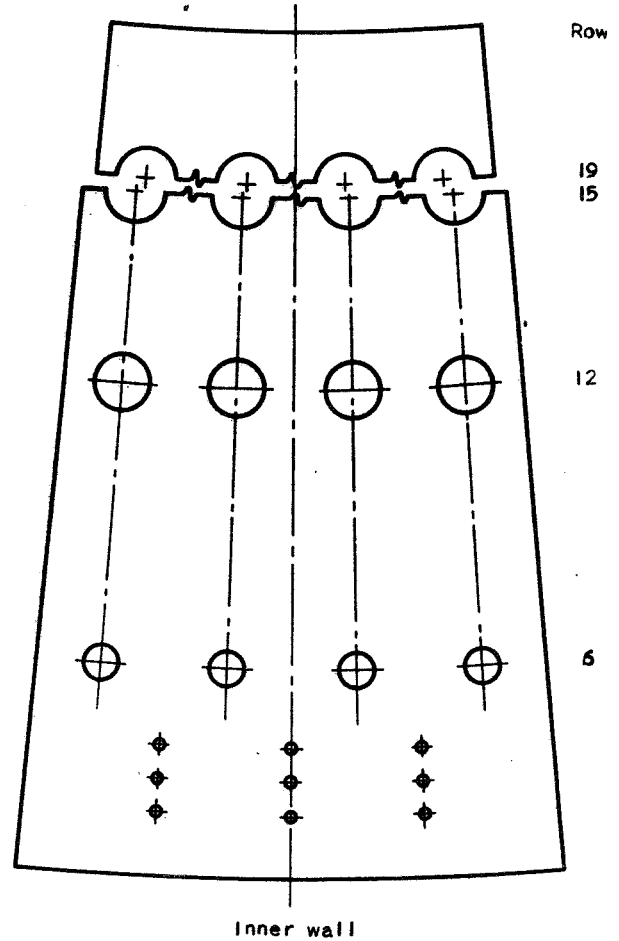

Figure 5. - Concluded. Development of basket walls of one-sixth combustor segment.

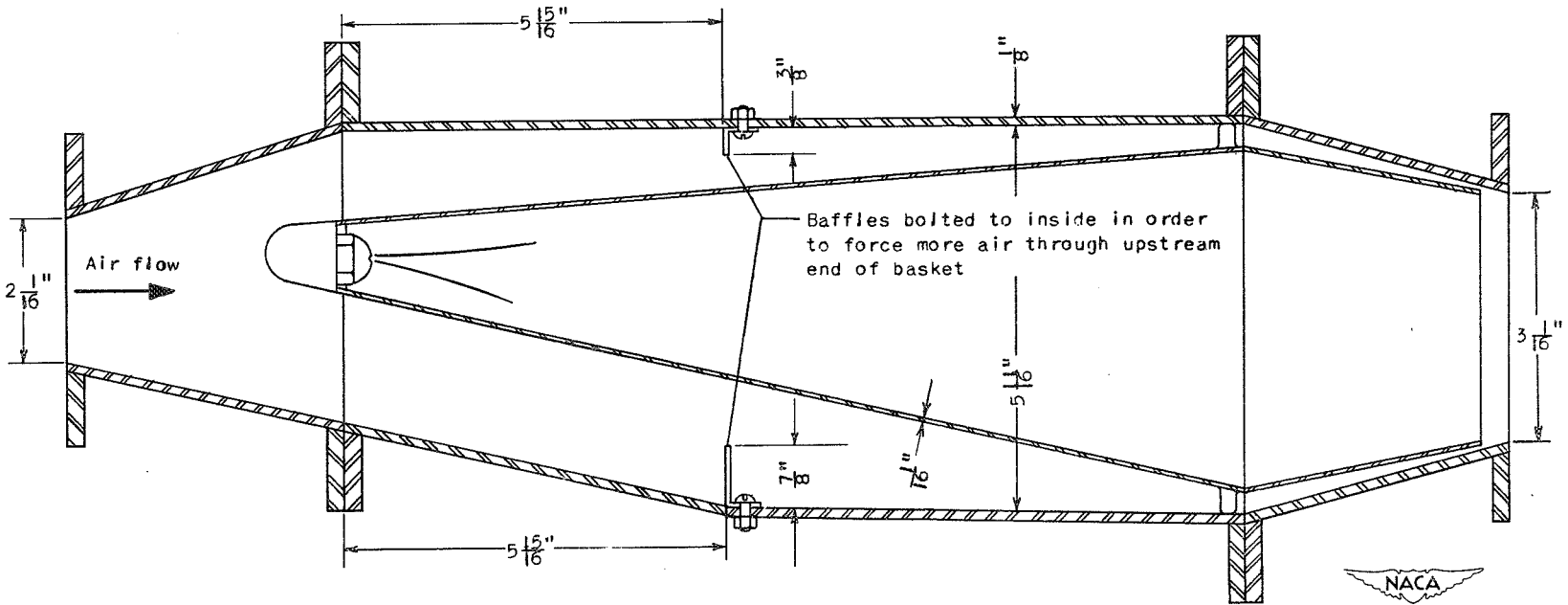
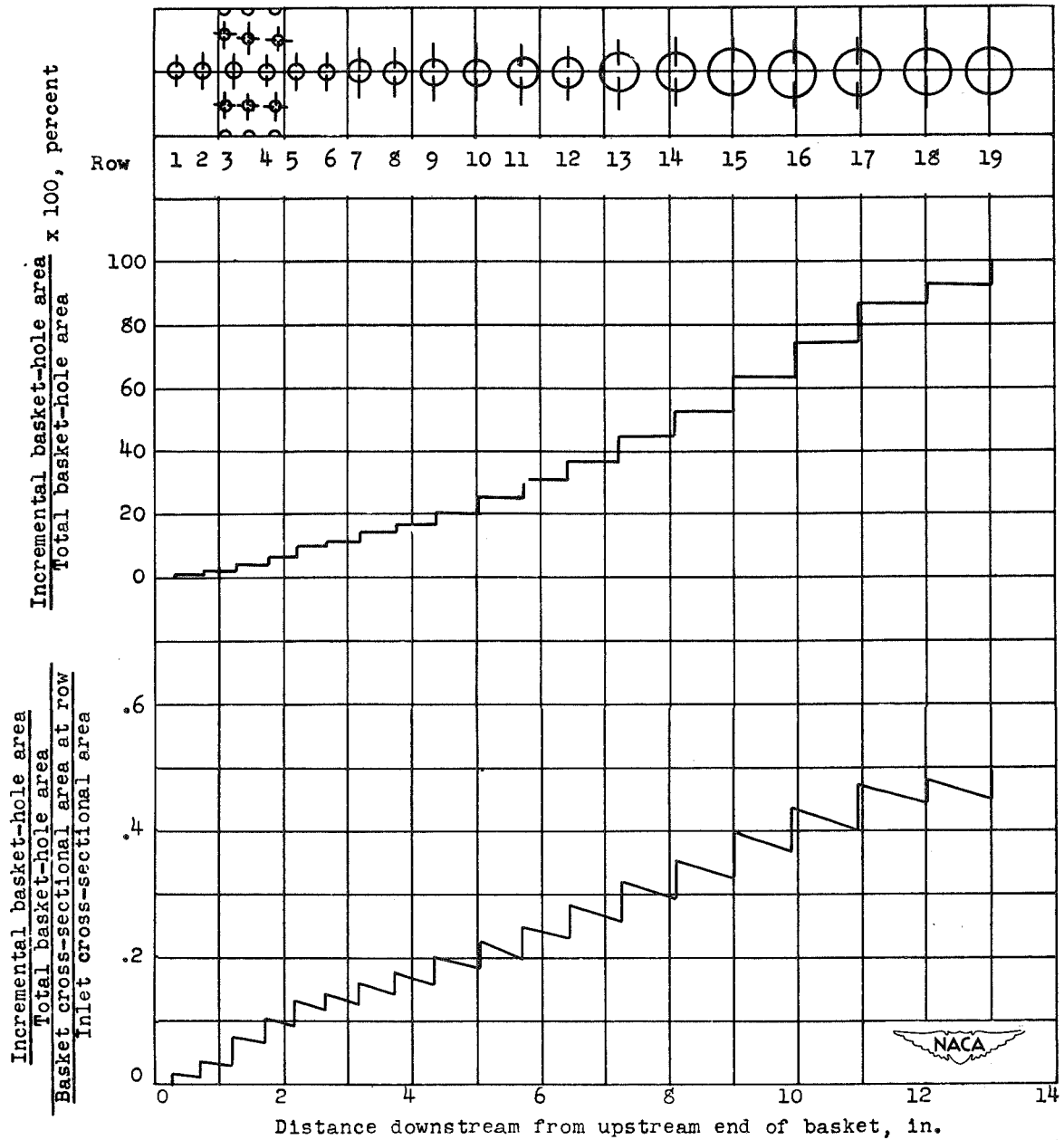

Figure 6. - Cross section of one-sixth combustor segment with modification 7. Basket-hole arrangement as originally designed.



(a) Original design.

Figure 7. - Axial distribution of hole area in basket and area-ratio representation of relative air velocities in combustion zone for non-burning conditions.

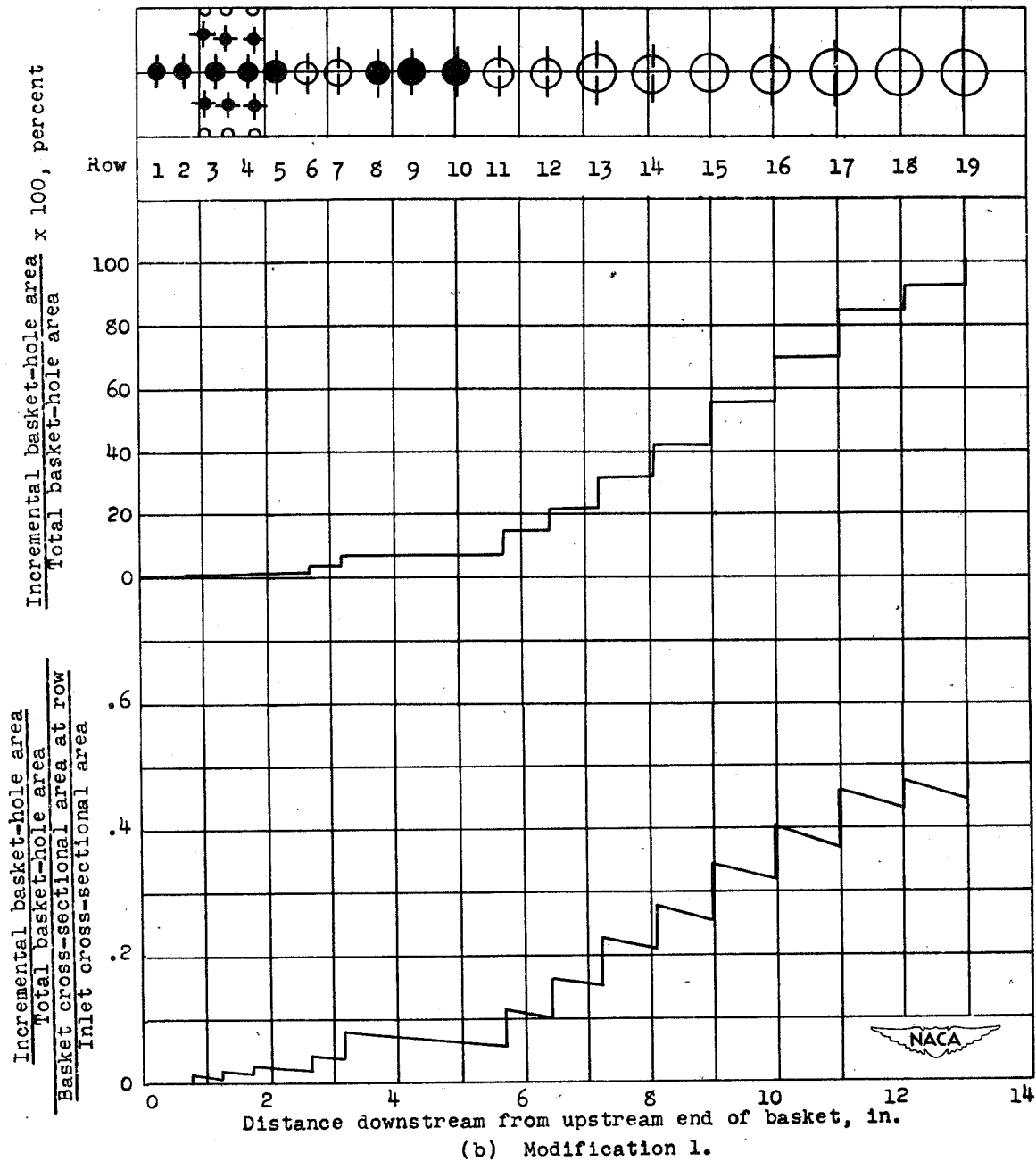
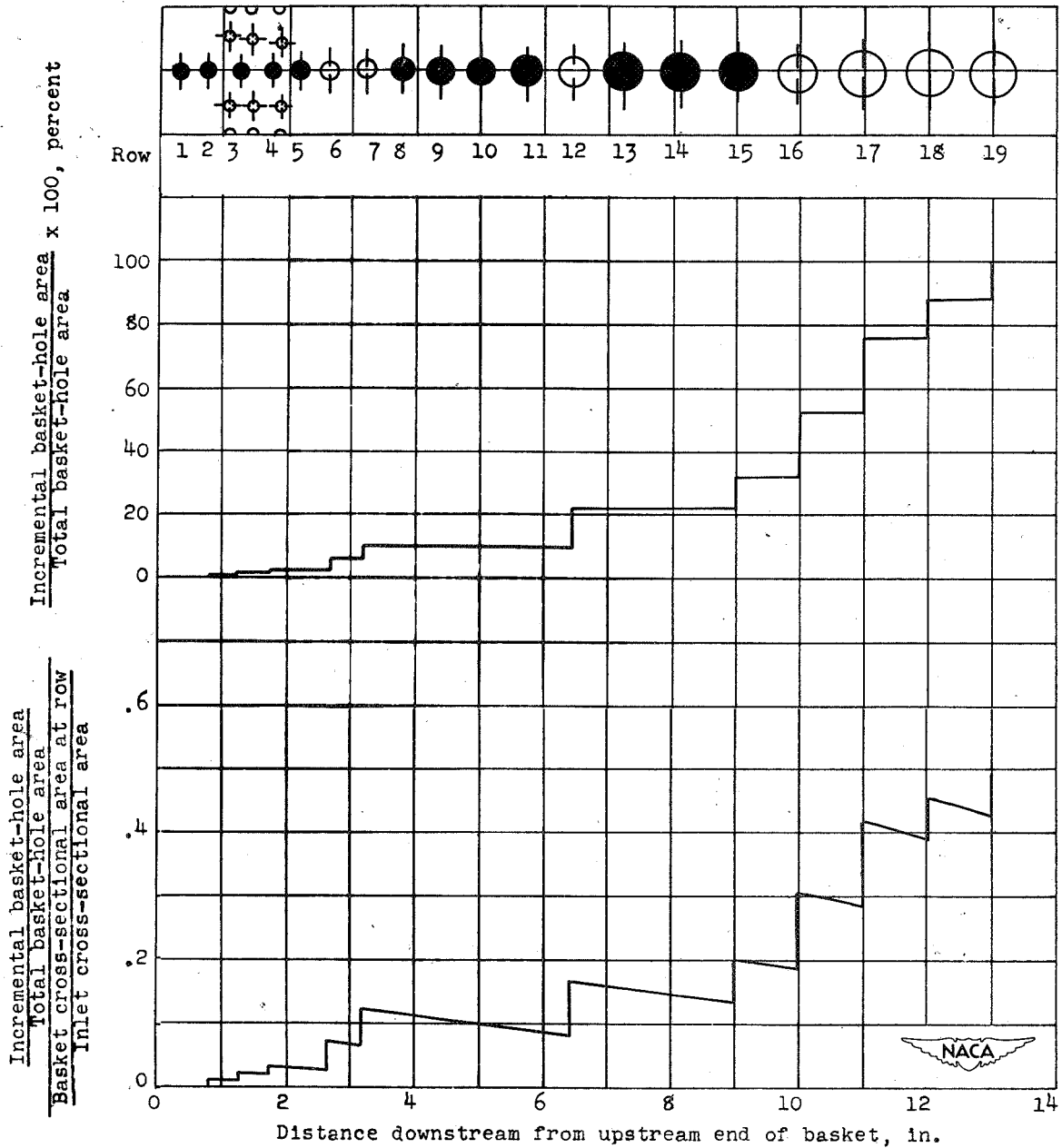

Figure 7. - Continued. Axial distribution of hole area in basket and area-ratio representation of relative air velocities in combustion zone for nonburning conditions.



(c) Modification 2.

Figure 7. - Continued. Axial distribution of hole area in basket and area-ratio representation of relative air velocities in combustion zone for nonburning conditions.

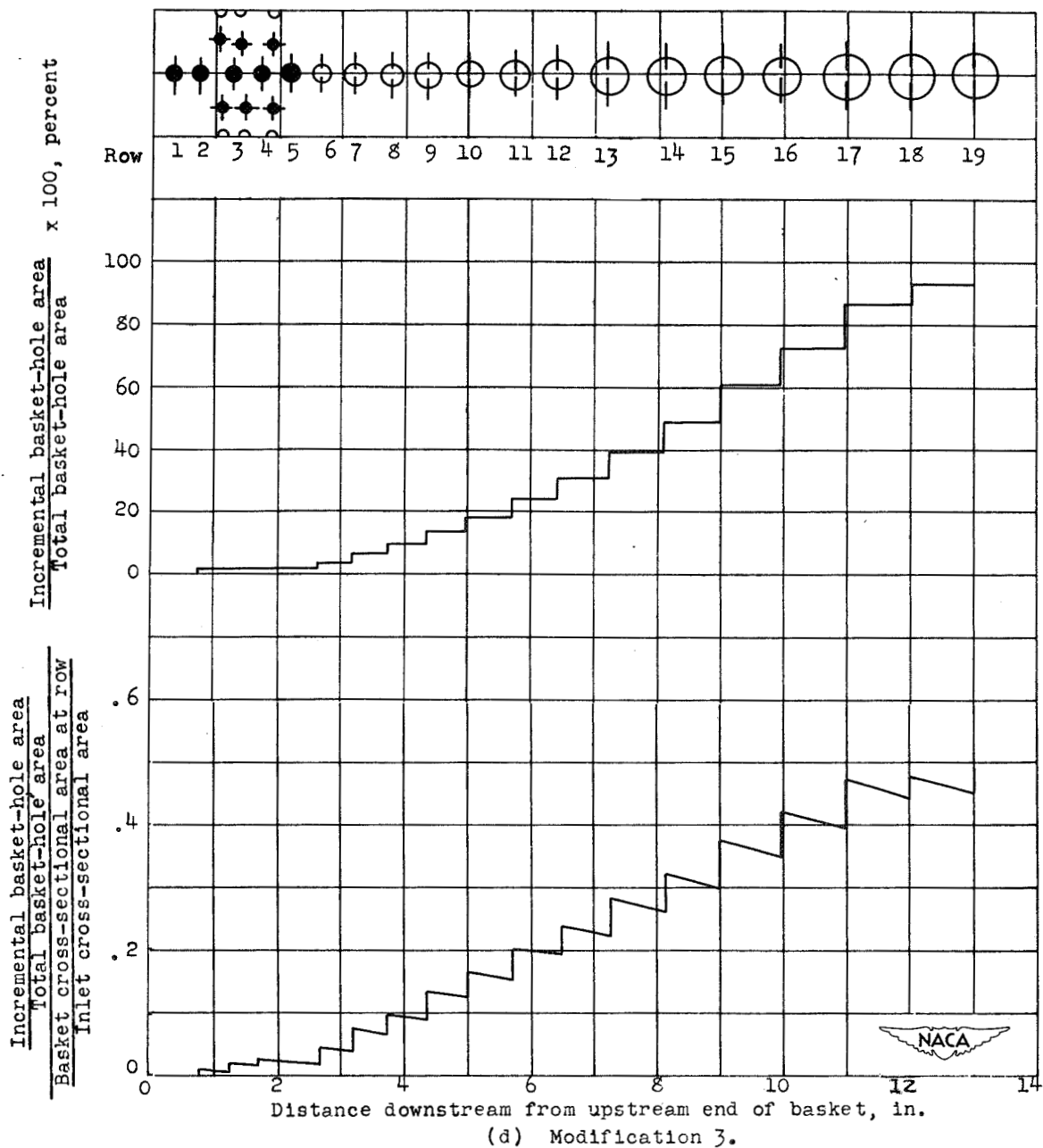

Figure 7. - Continued. Axial distribution of hole area in basket and area-ratio representation of relative air velocities in combustion zone for nonburning conditions.

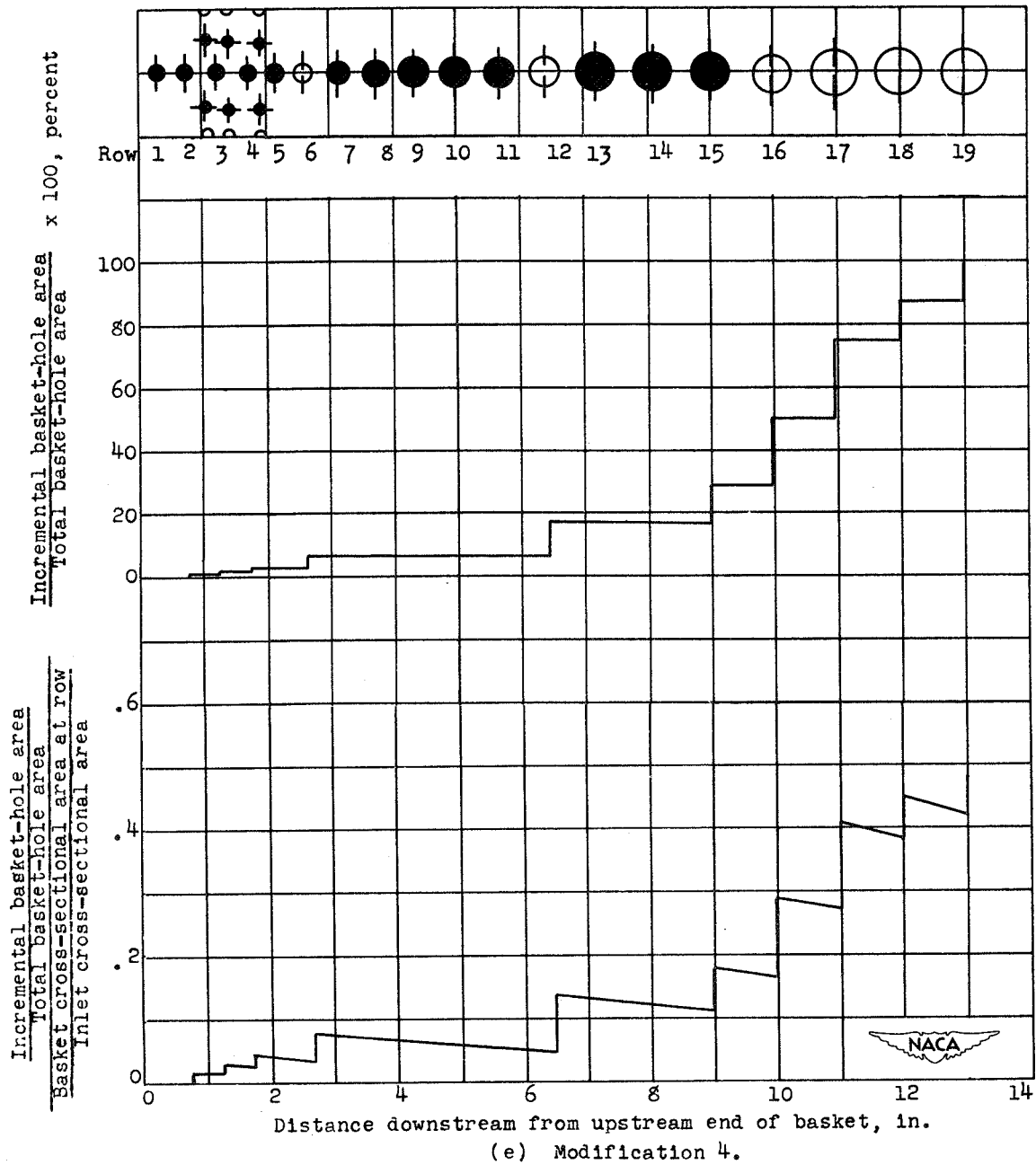
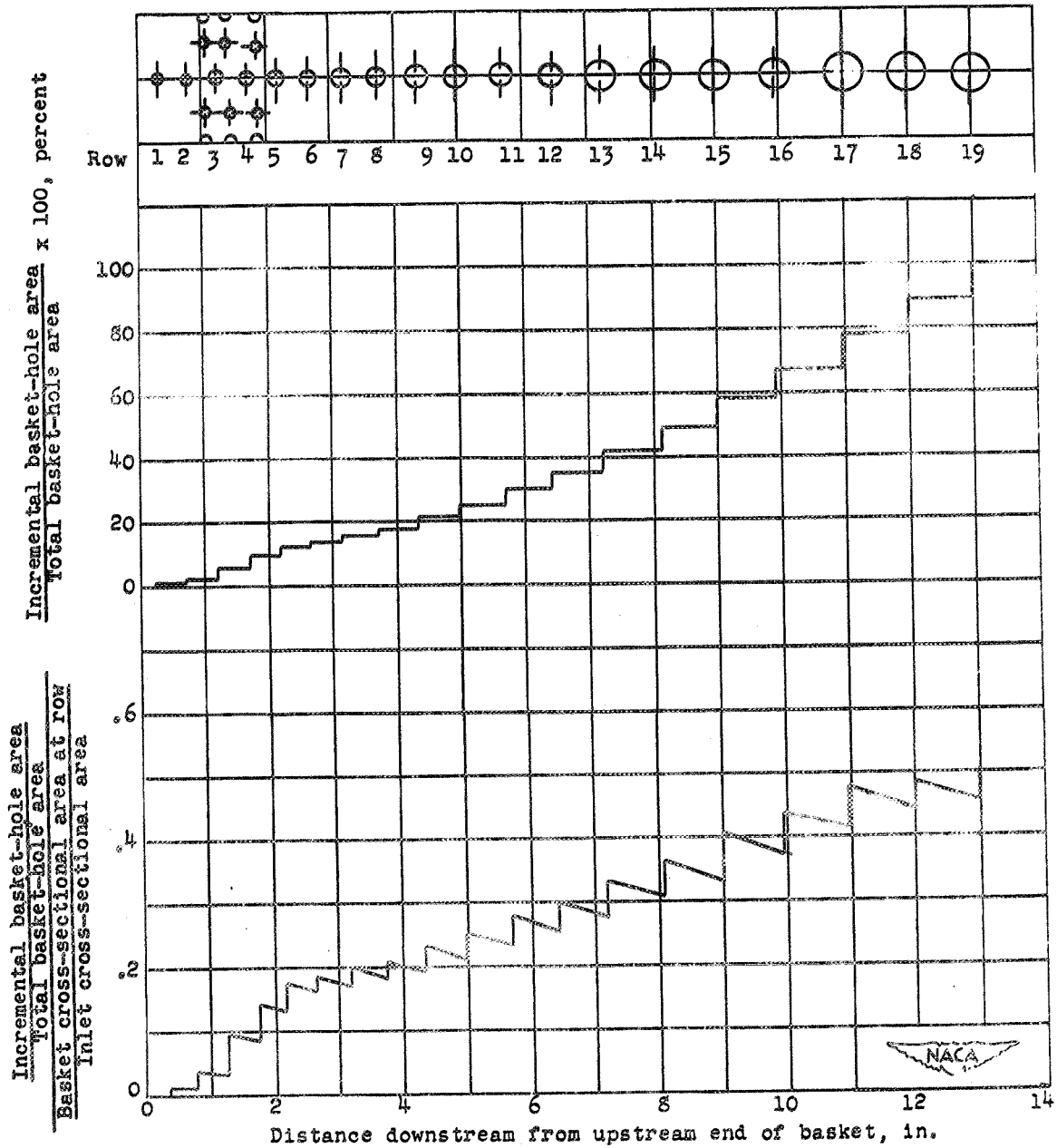

Figure 7. - Continued. Axial distribution of hole area in basket and area-ratio representation of relative air velocities in combustion zone for nonburning conditions.



(f) Modification 5.

Figure 7. - Continued. Axial distribution of hole area in basket and area-ratio representation of relative air velocities in combustion zone for nonburning conditions.

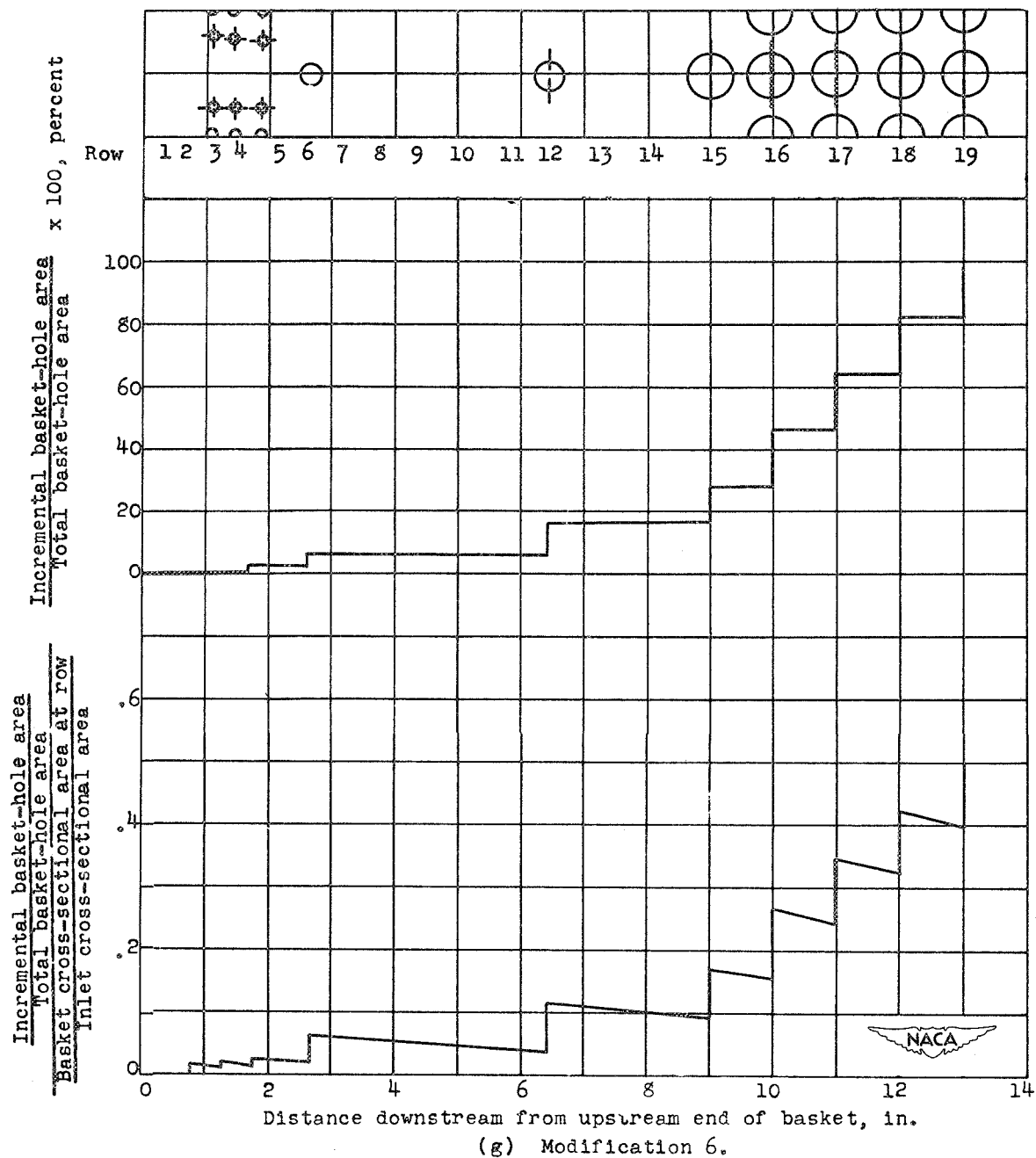
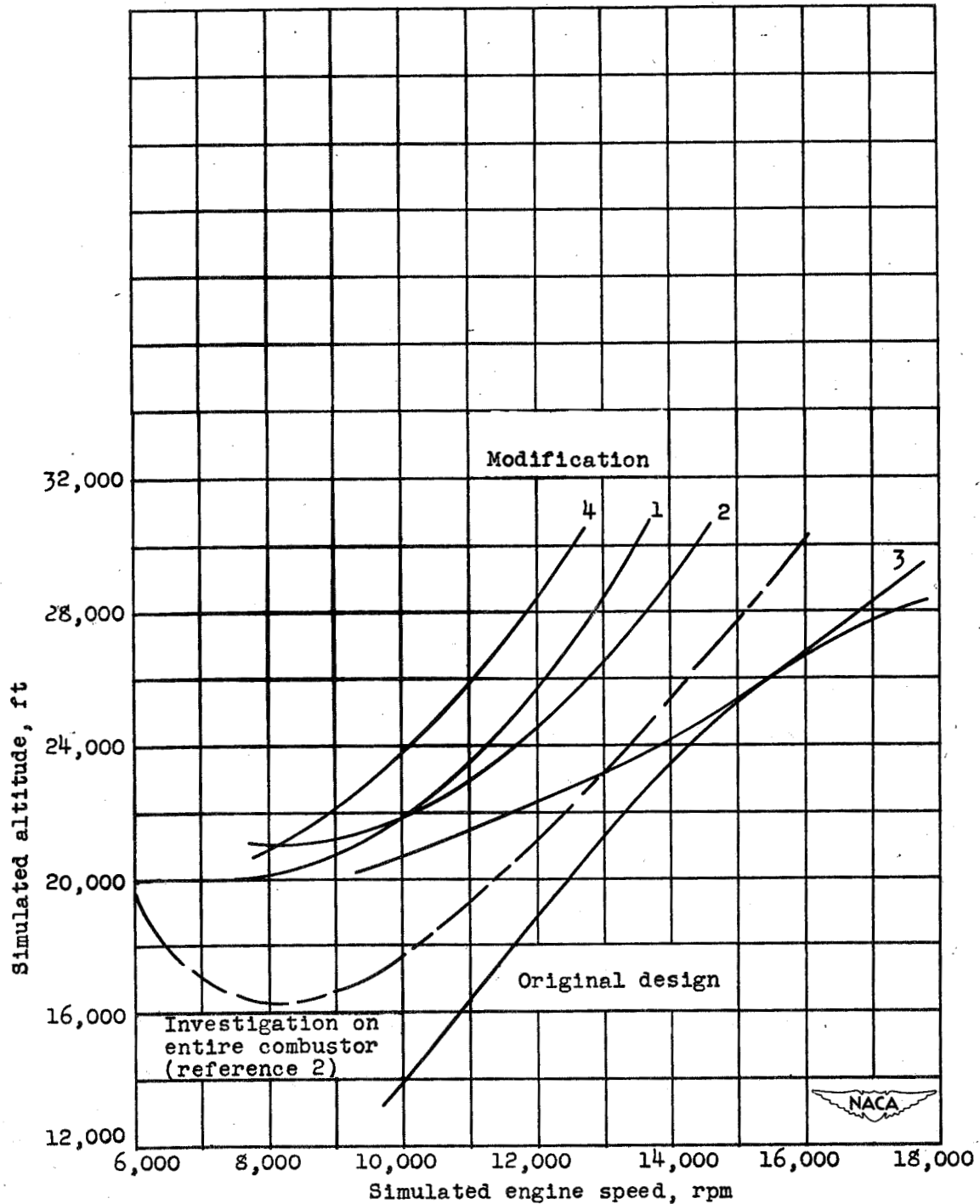
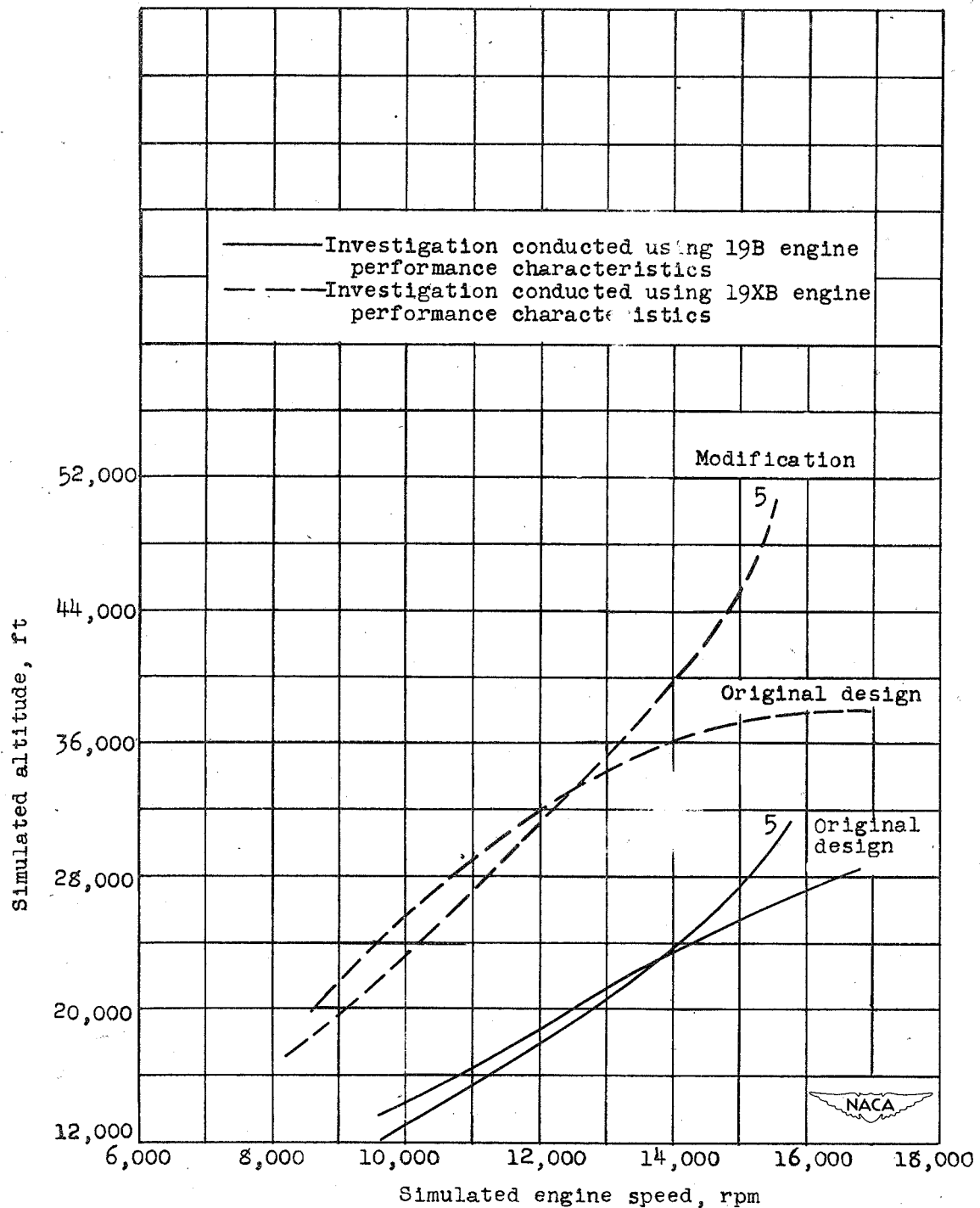

Figure 7. - Concluded. Axial distribution of hole area in basket and area-ratio representation of relative air velocities in combustion zone for nonburning conditions.



(a) Effect of basket-hole modifications. Investigation conducted using 19B engine performance characteristics.

Figure 8. - Altitude operational limits of one-sixth segment of annular turbojet combustor.



(b) Effect of changes in total-pressure loss through basket.
Original air distribution.

Figure 8. - Continued. Altitude operational limits of one-sixth segment of annular turbojet combustor.

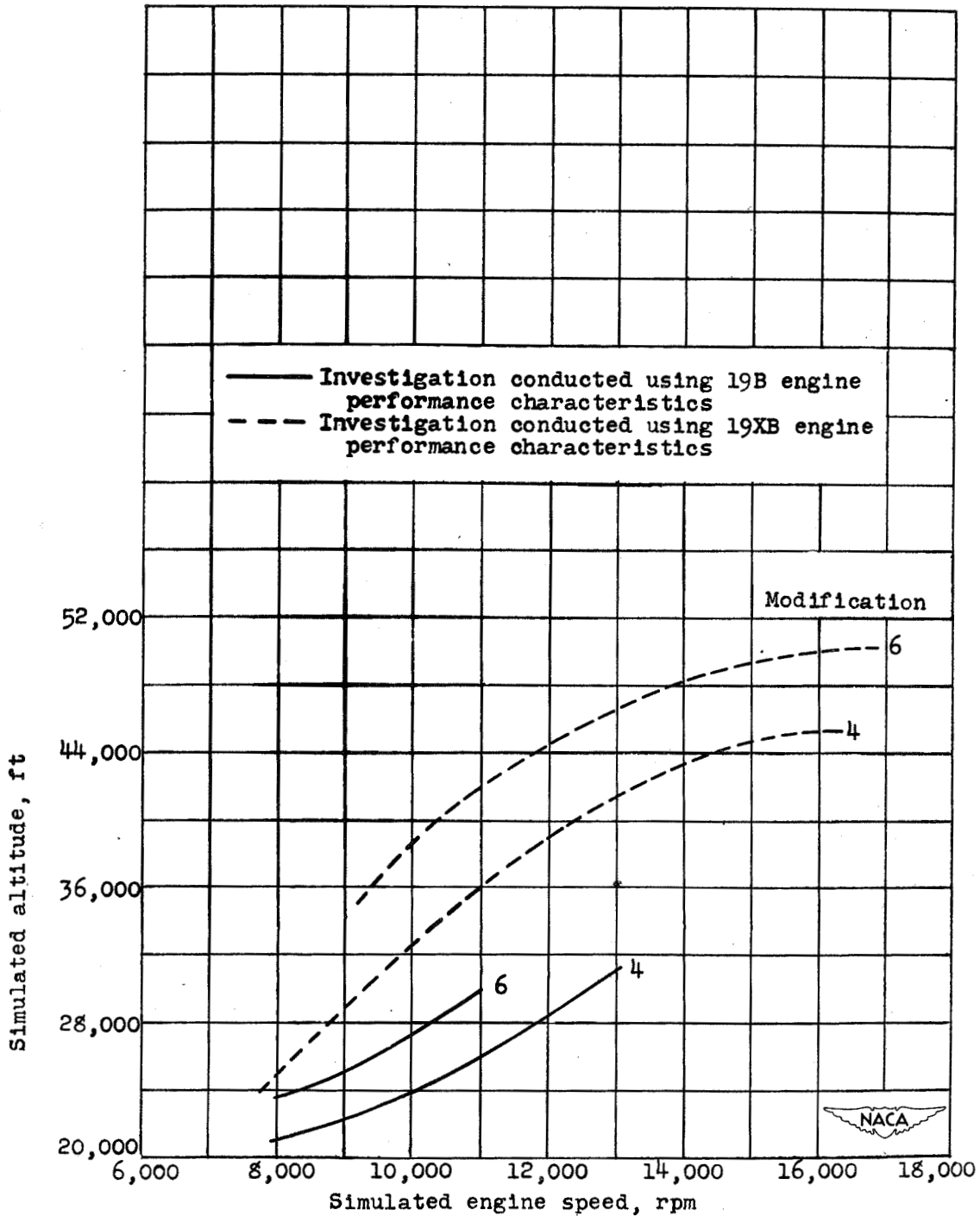

(c) Effect of changes in total-pressure loss through basket. Modified air distribution.

Figure 8. - Continued. Altitude operational limits of one-sixth segment of annular turbojet combustor.

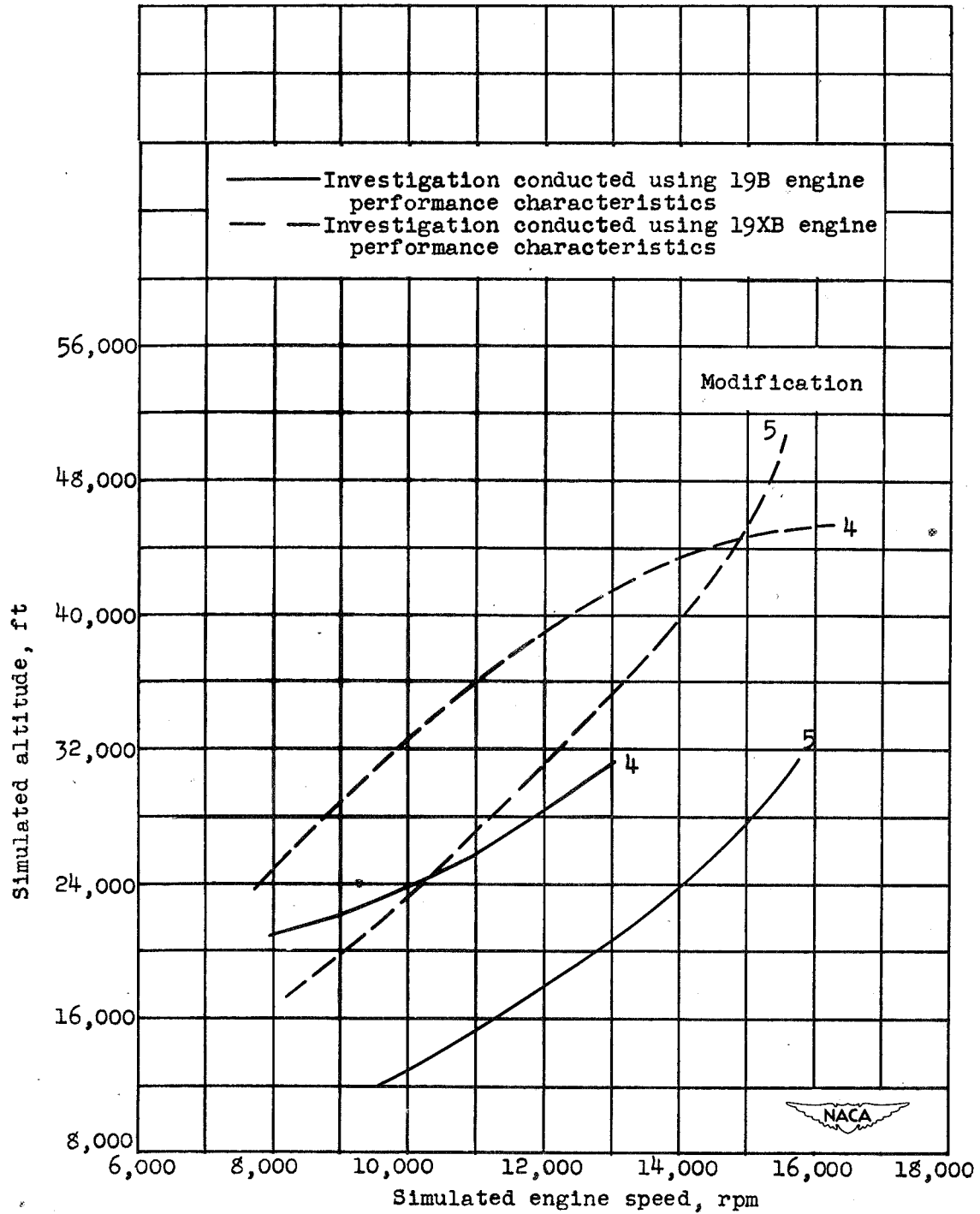

(d) Effect of air-flow distribution through basket. High combustor total-pressure loss.

Figure 8. - Continued. Altitude operational limits of one-sixth segment of annular turbojet combustor.

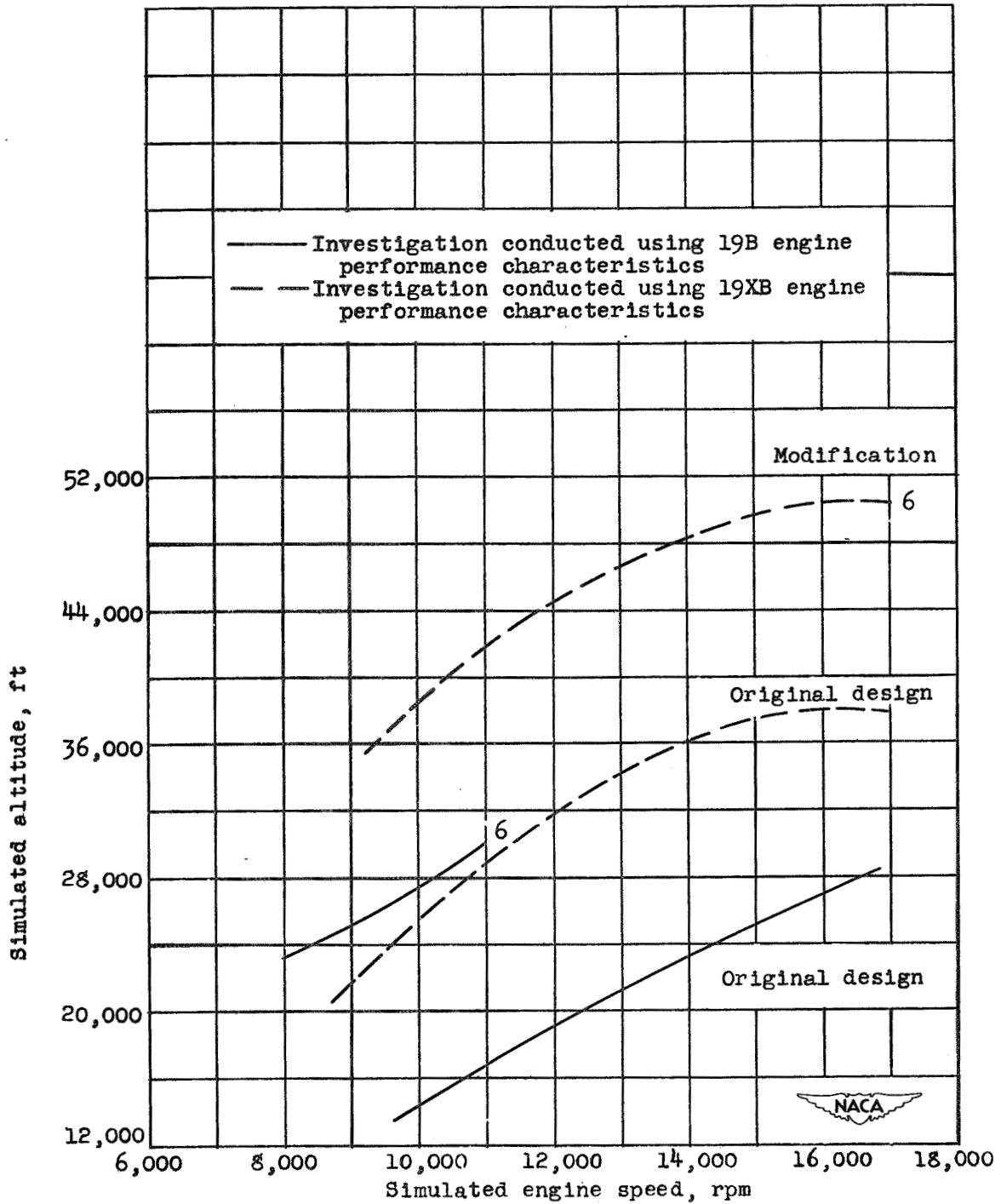

(e) Effect of air-flow distribution through basket. Low combustor total-pressure loss.

Figure 8. - Concluded. Altitude operational limits of one-sixth segment of annular turbojet combustor.

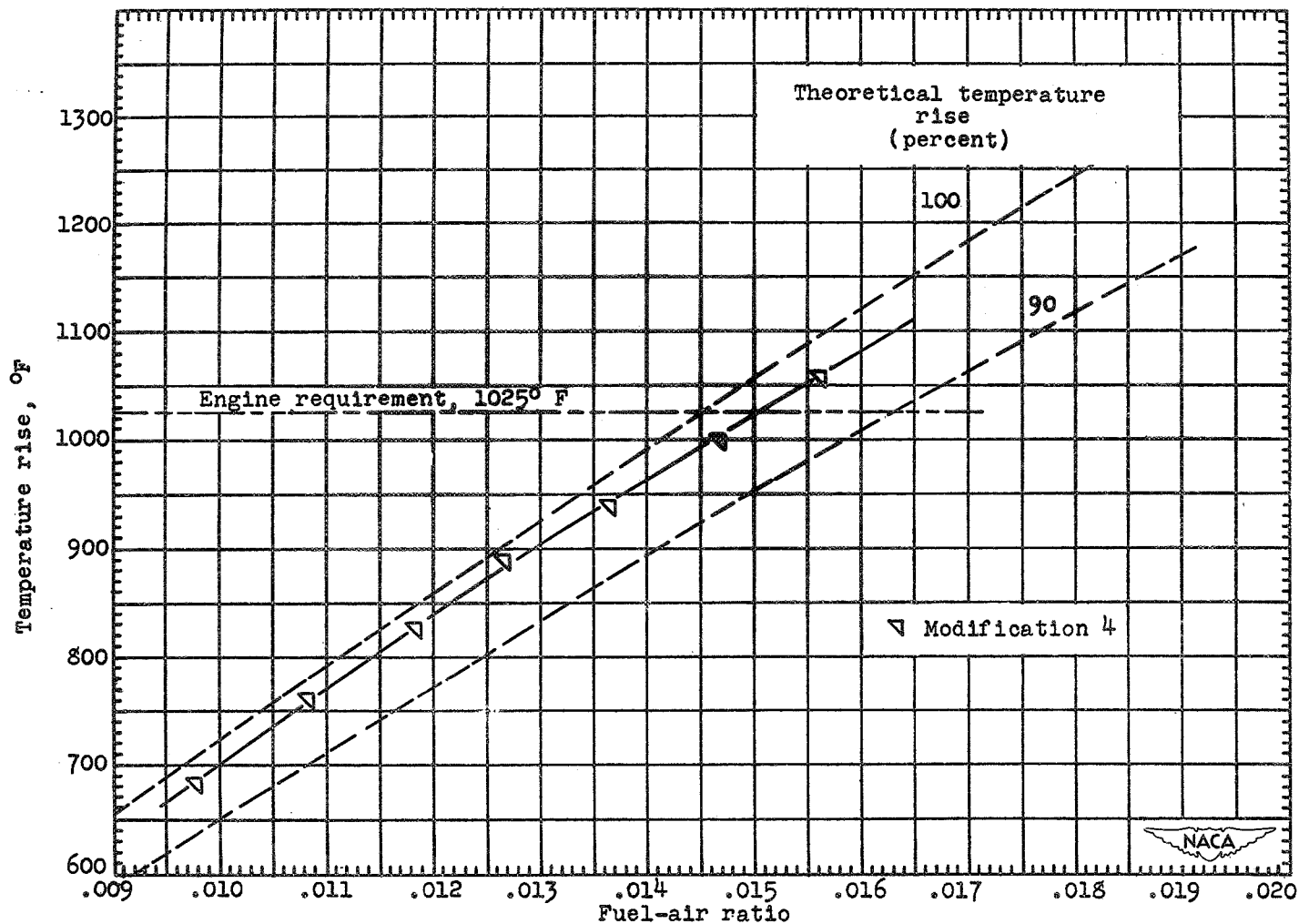

(a) Operating conditions for 19B engine at sea level and engine speed of 17,000 rpm: air flow, 4.85 pounds per second; inlet-air total pressure, 42.8 pounds per square inch absolute; inlet-air temperature, 300° F.

Figure 9. - Effect of fuel-air-ratio variation on temperature rise through combustor.

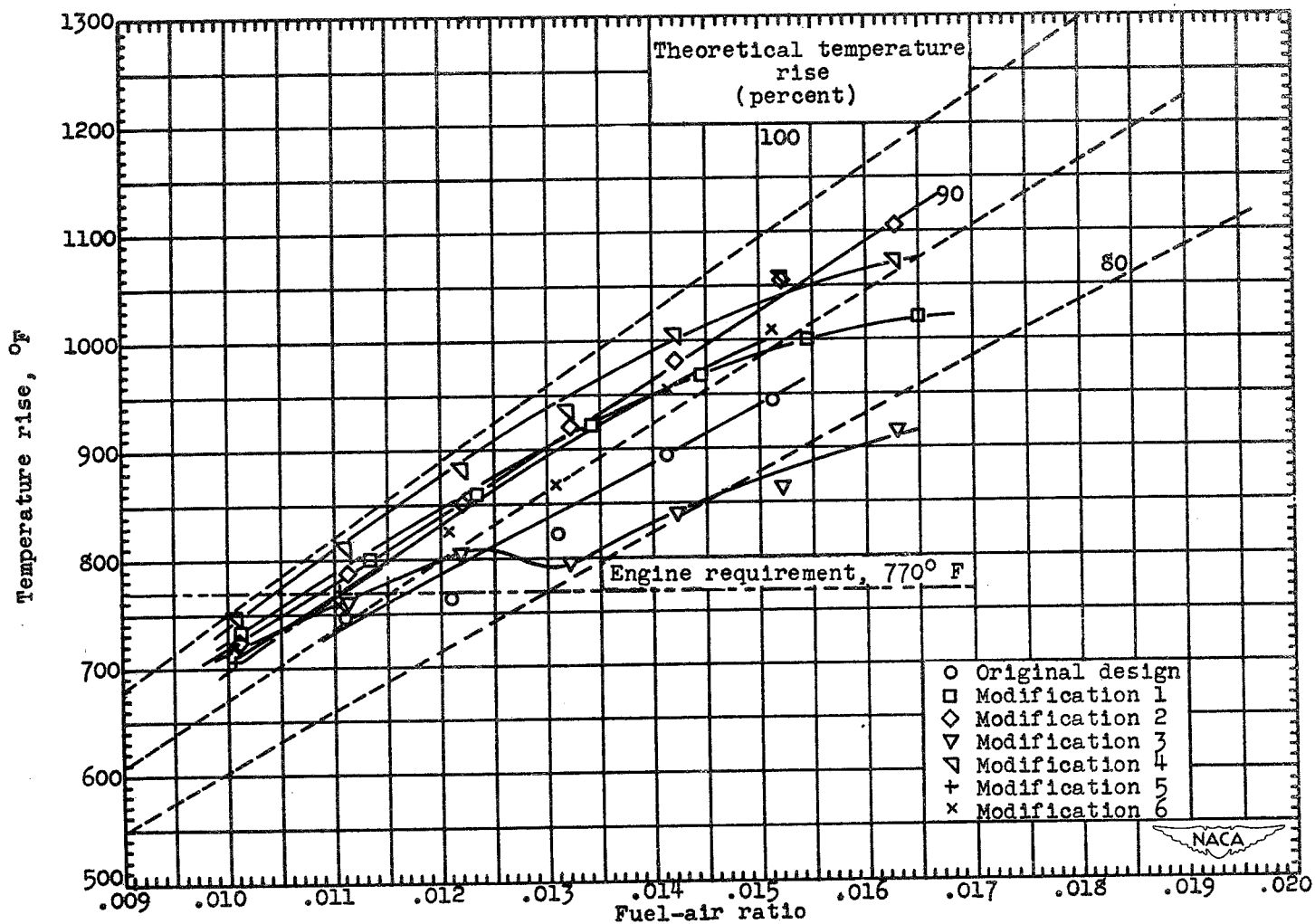

(b) Operating conditions for 19B engine at altitude of 5000 feet and engine speed of 12,000 rpm: air flow, 2.77 pounds per second; inlet-air total pressure, 23.0 pounds per square inch absolute; inlet-air temperature, 155° F.

Figure 9. - Continued. Effect of fuel-air-ratio variation on temperature rise through combustor.

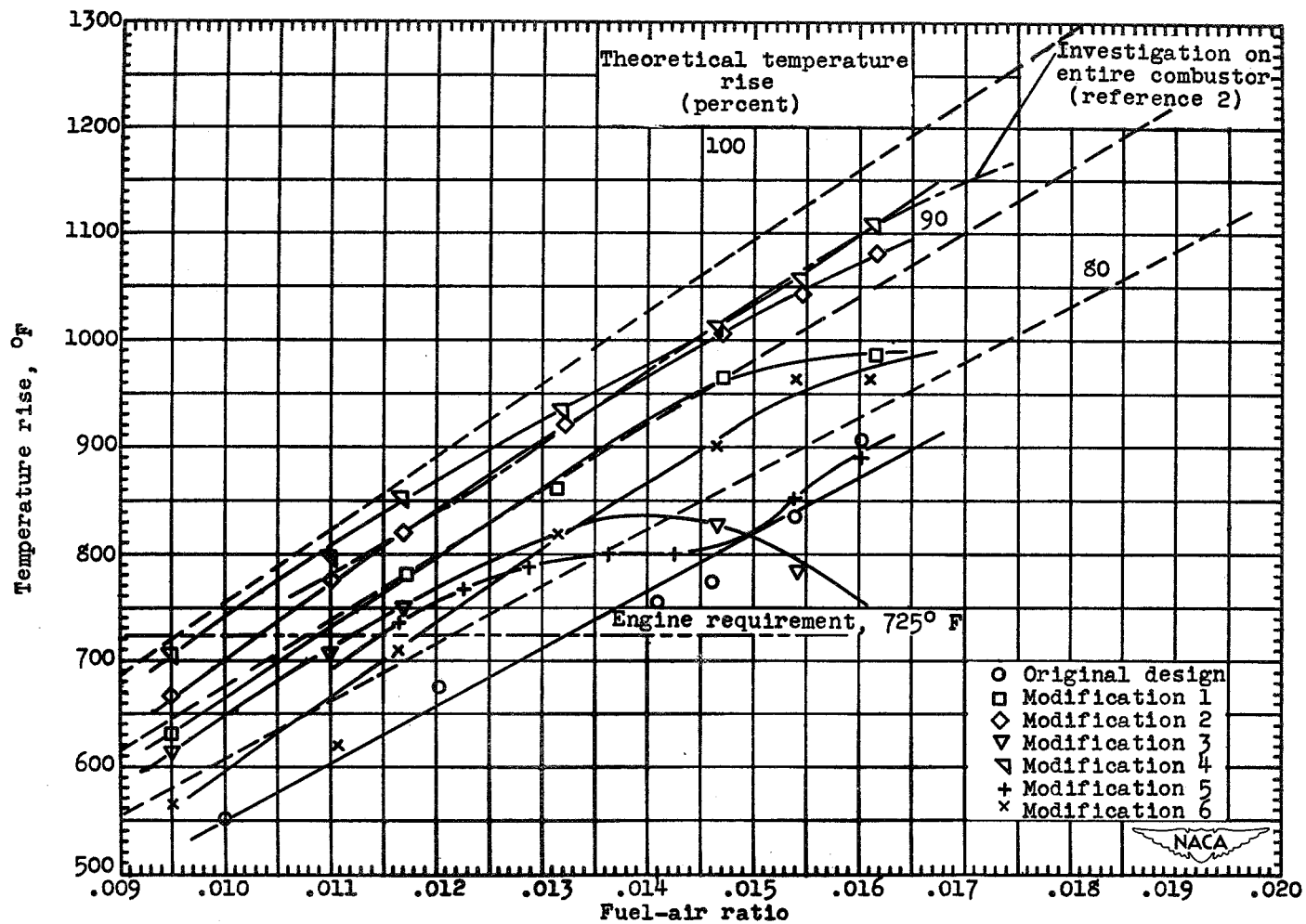

(c) Operating conditions for 19B engine at altitude of 16,000 feet and engine speed of 10,000 rpm with 20-percent excess of normal inlet total pressure: air flow, 1.91 pounds per second; inlet-air total pressure, 16.1 pounds per square inch absolute; inlet-air temperature, 80° F.

Figure 9. - Continued. Effect of fuel-air-ratio variation on temperature rise through combustor.

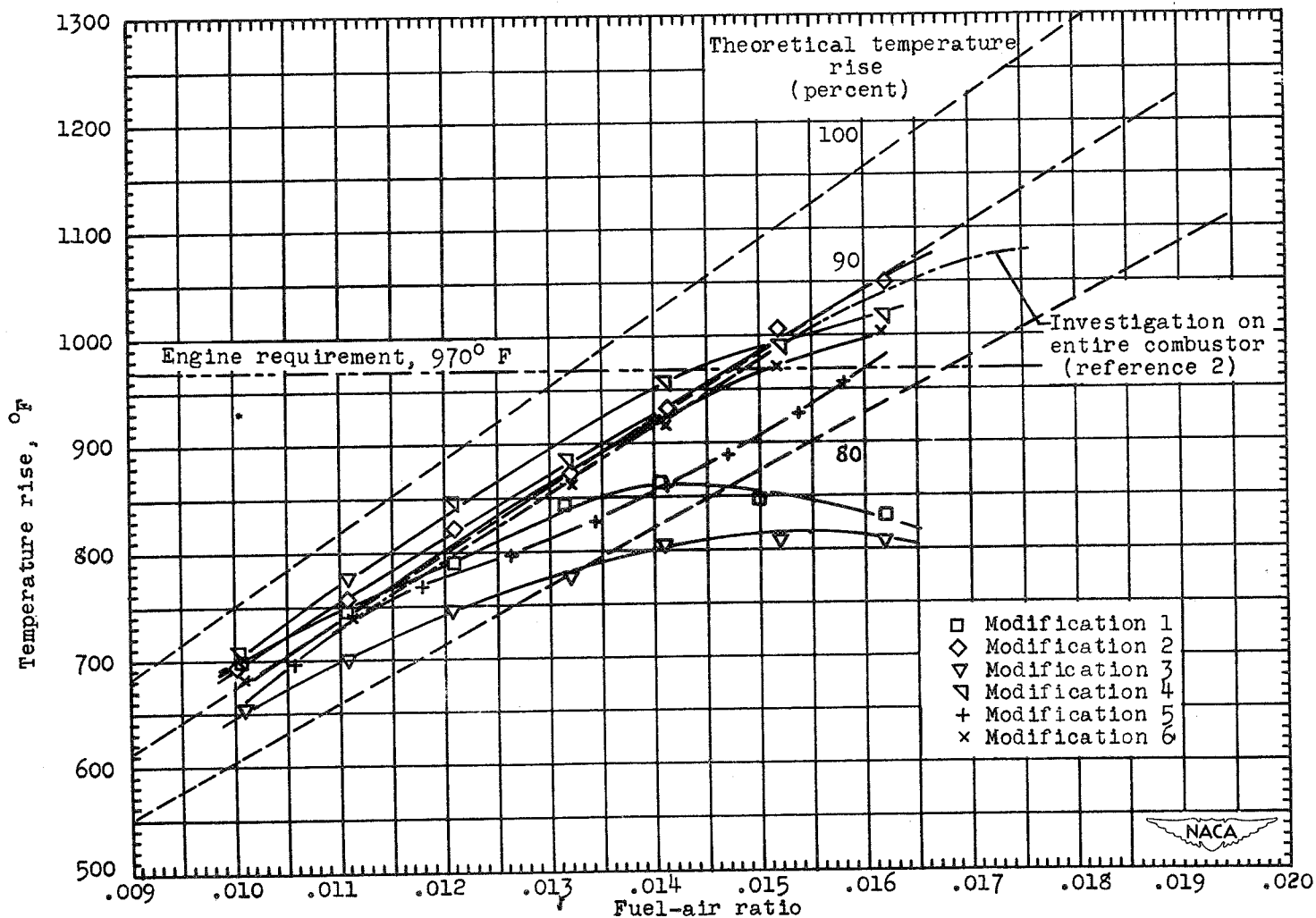

(d) Operating conditions for 19B engine at altitude of 30,000 feet and engine speed of 16,500 rpm: air flow, 1.87 pounds per second; inlet-air total pressure, 16.0 pounds per square inch absolute; inlet-air temperature, 190° F.

Figure 9. - Concluded. Effect of fuel-air-ratio variation on temperature rise through combustor.

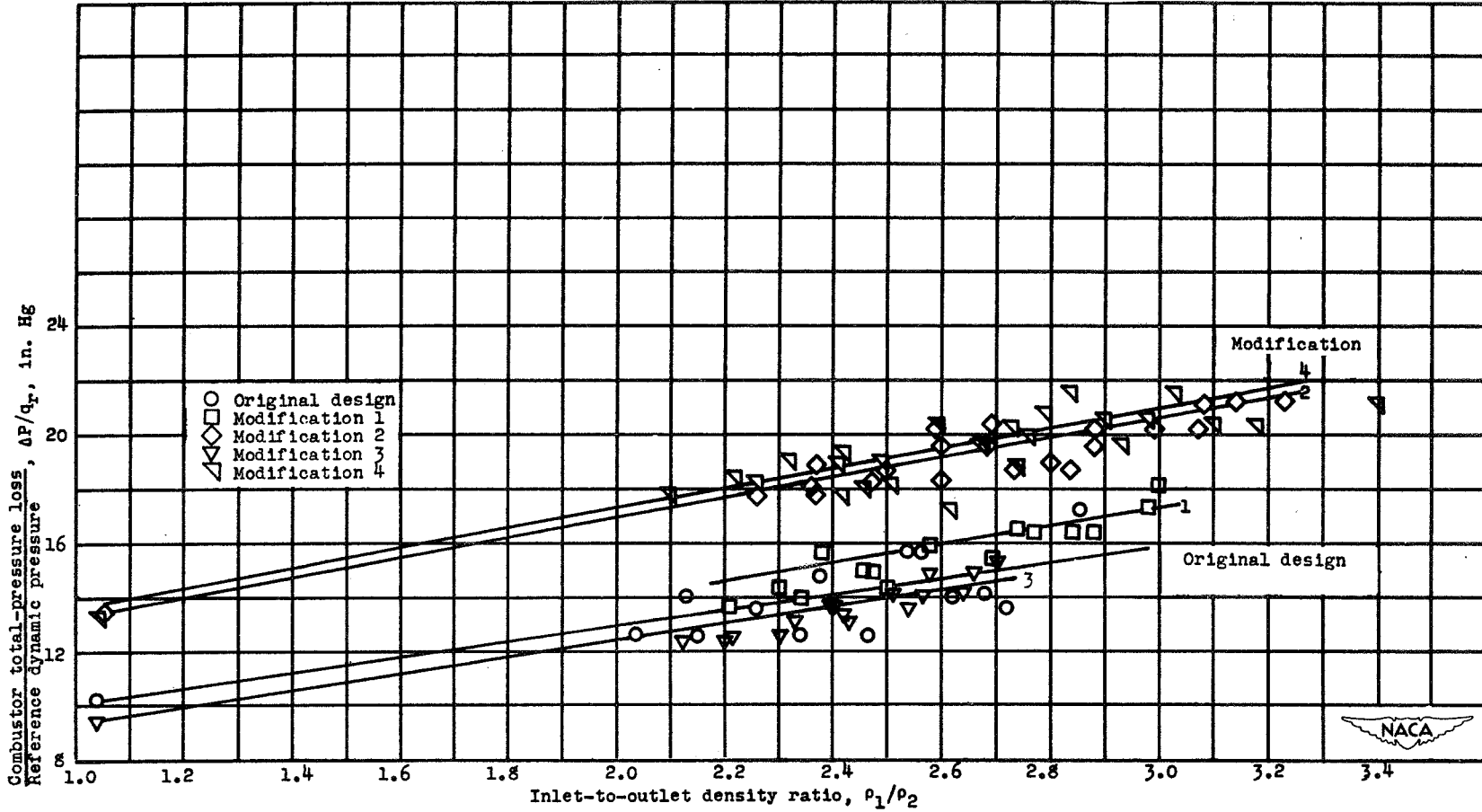

(a) Comparison of original design and modifications 1, 2, 3, and 4.

Figure 10. - Total-pressure loss through combustor segment shown as function of inlet-to-outlet density ratio.

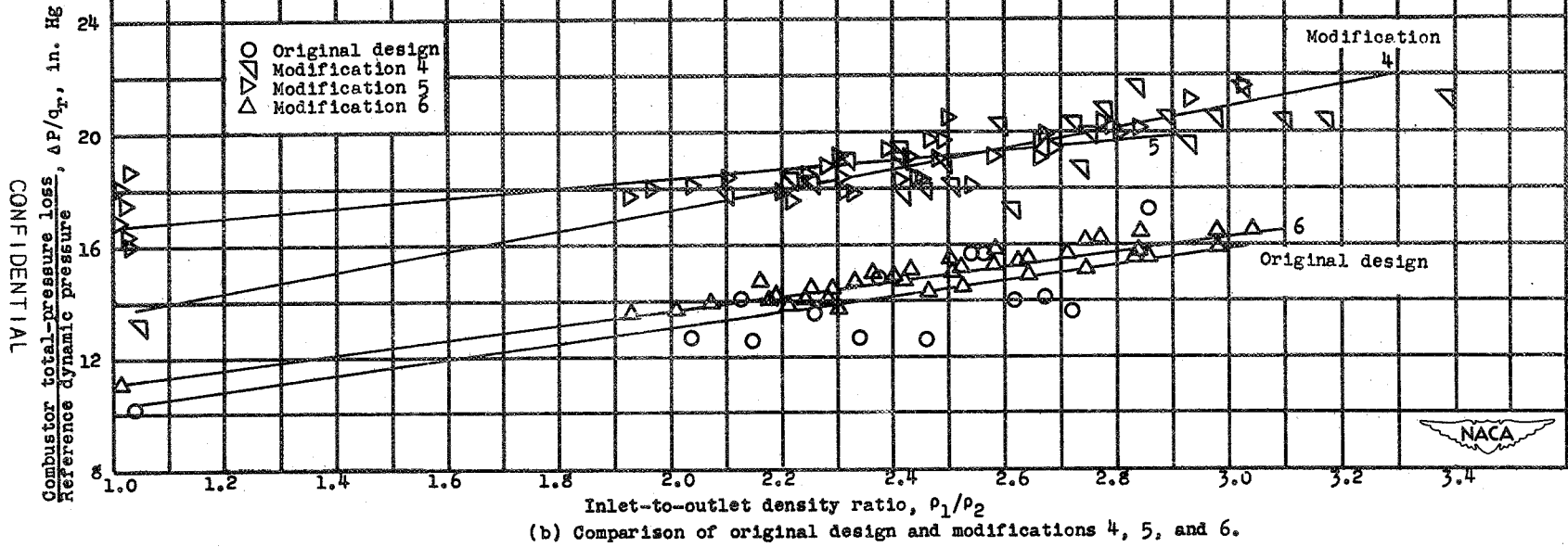
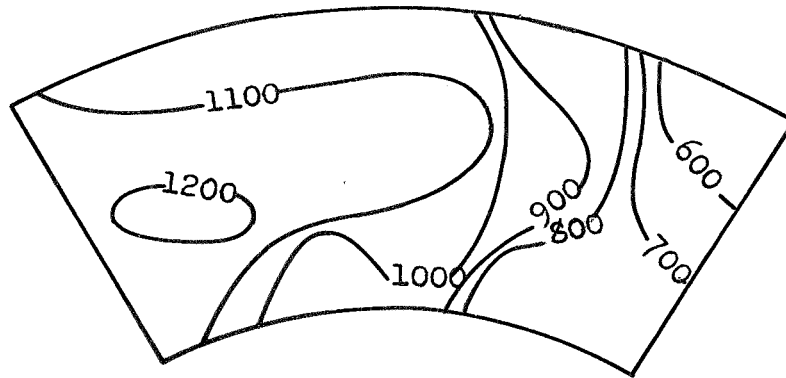
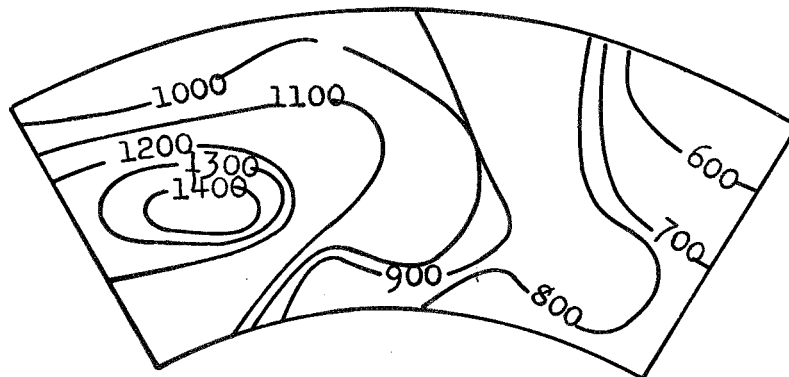

Figure 10. - Concluded. Total-pressure loss through combustor segment shown as function of inlet-to-outlet density ratio.



(a) Original design. Average combustor-outlet temperature, 970° F.



(b) Modification 1. Average combustor-outlet temperature, 952° F.

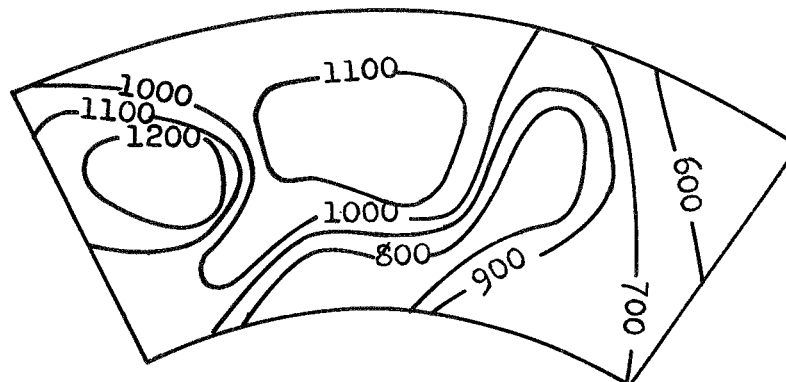

(c) Modification 2. Average combustor-outlet temperature, 960° F.



Figure 11. - Combustor-outlet cross section showing temperature pattern of gases entering turbine. Altitude, 5000 feet; engine speed, 12,000 rpm; required combustor-outlet temperature, 930° F; 19B engine. All temperatures are given in $^{\circ}$ F.

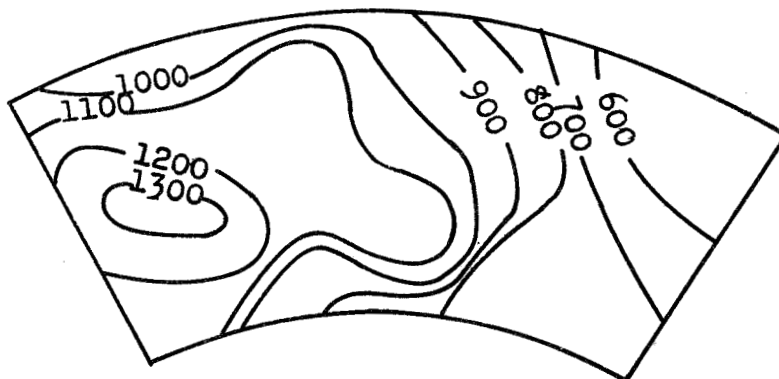

(d) Modification 3. Average combustor-outlet temperature, 953° F.

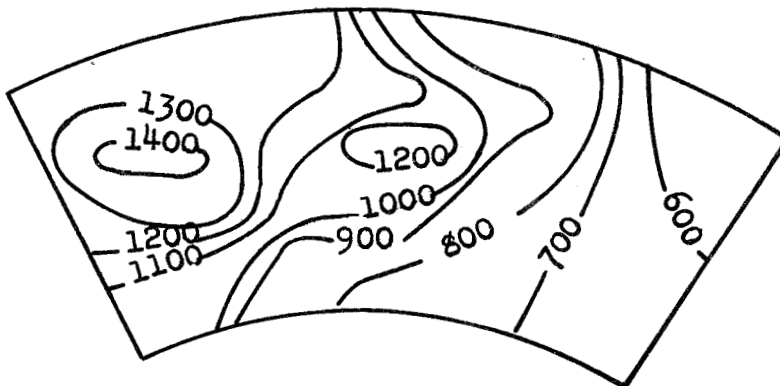

(e) Modification 4. Average combustor-outlet temperature, 969° F.



Figure 11. - Continued. Combustor-outlet cross section showing temperature pattern of gases entering turbine. Altitude, 5000 feet; engine speed, 12,000 rpm; required combustor-outlet temperature, 930° F; 19B engine. All temperatures are given in °F.

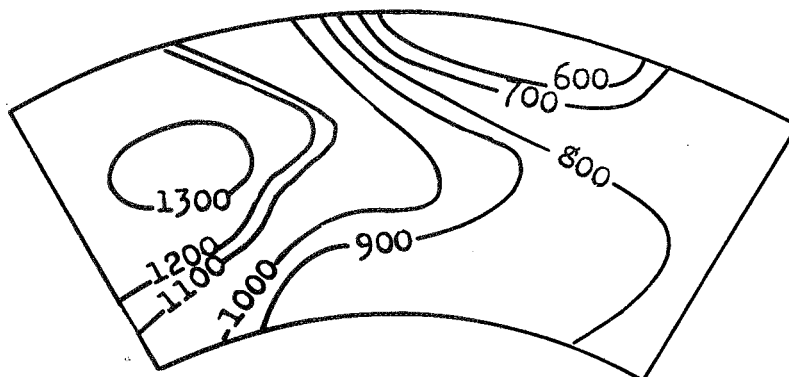

(f) Modification 5. Average combustor-outlet temperature, 924° F.

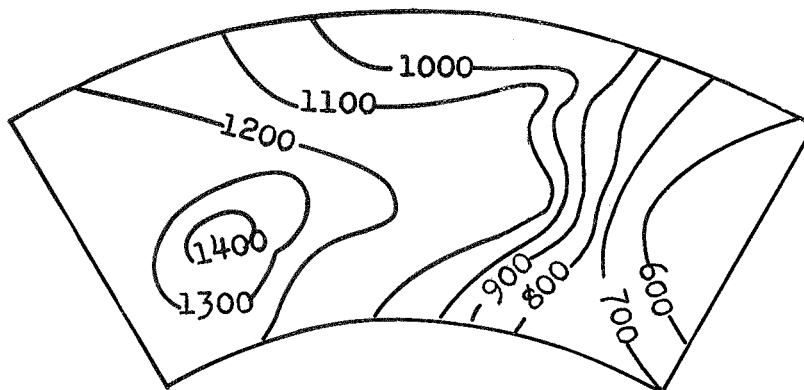

(g) Modification 6. Average combustor-outlet temperature, 984° F.



Figure 11. - Concluded. Combustor-outlet cross section showing temperature pattern of gases entering turbine. Altitude, 5000 feet; engine speed, 12,000 rpm; required combustor-outlet temperature, 930° F; 19B engine. All temperatures are given in $^{\circ}$ F.

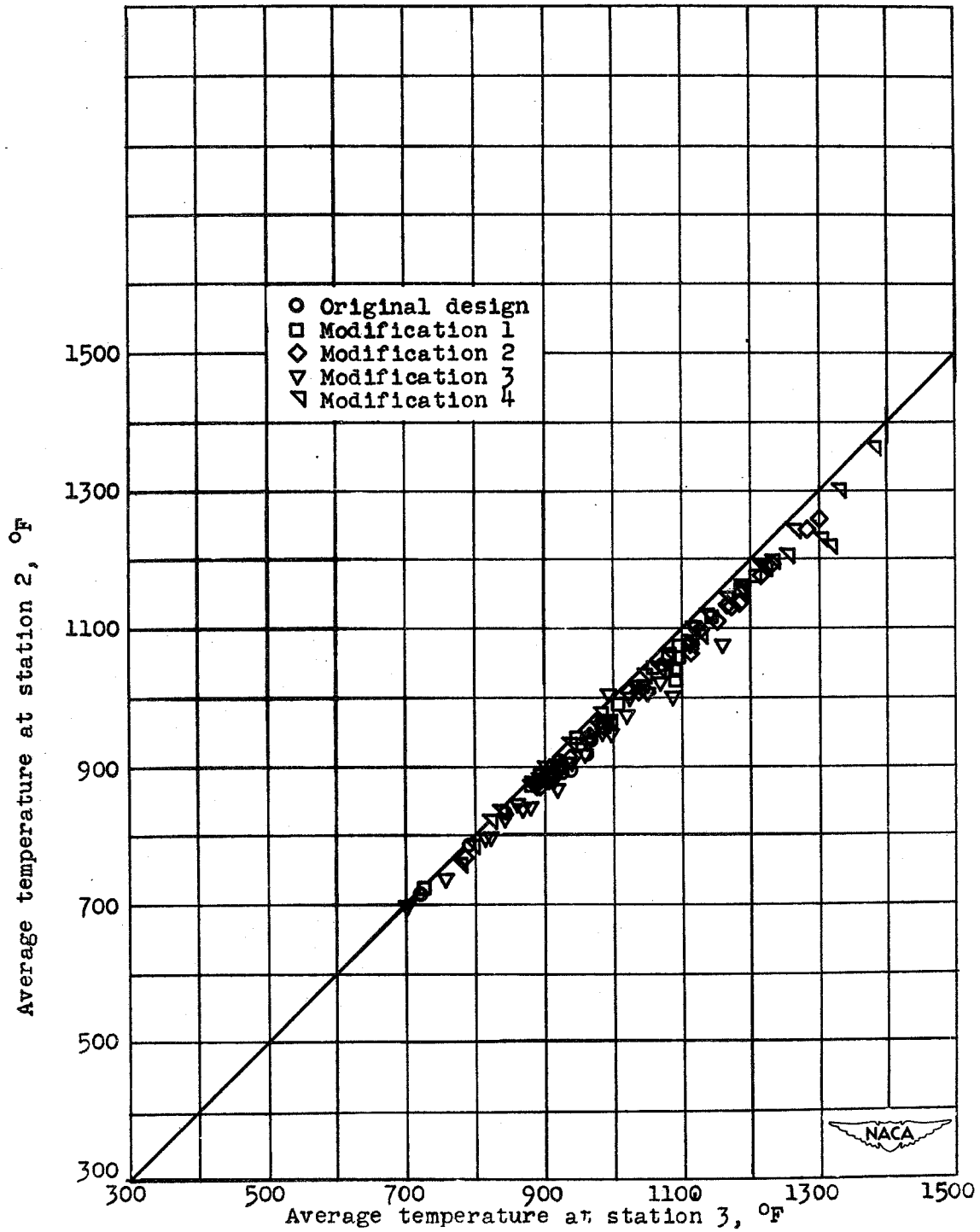

Figure 12. - Comparison of thermocouple rake average at station 2 with thermocouple rake average at station 3.