

Source of Acquisition
CASI Acquired

Copy 1
RM 519F17

PERMANENT FILE COPY

~~CLASSIFICATION CANCELLED~~

~~J. W. Crowley~~
NACA

~~NACA~~

~~110752~~
~~McDonnell~~
~~F-111~~

OLS

NACA change # 2935

Status: INACTIVE

RESEARCH MEMORANDUM

for the

Bureau of Aeronautics, Department of the Navy

~~CLASSIFICATION CANCELLED~~

FREE-SPINNING-TUNNEL INVESTIGATION OF A $\frac{1}{20}$ -SCALE MODEL

OF THE McDONNELL XF2H-1 AIRPLANE

By

Theodore Berman

Langley Aeronautical Laboratory
Langley Air Force Base, Va.

~~CLASSIFICATION CANCELLED~~

~~CLASSIFICATION CANCELLED~~

~~J. W. Crowley~~ 10/10/53

OLS

NACA change # 1908

This document contains classified information within the meaning of the Espionage Act, 18 USC 793 and 794. Its transmission or the revelation of its contents in any manner to an unauthorized person is prohibited by law. Information so classified may be imparted only to persons in the military and naval services of the United States, or to other civilian officers and employees of the Government who have a legitimate interest therein, and to United States citizens of known loyalty and discretion who of necessity must be informed thereof.

NATIONAL ADVISORY COMMITTEE FOR AERONAUTICS FILE COPY

WASHINGTON
JUN 24 1949

To be returned to
the file of the National
Advisory Committee
for Aeronautics
Washington, D.C.

114

~~CLASSIFICATION CANCELLED~~

~~CLASSIFICATION CANCELLED~~

NATIONAL ADVISORY COMMITTEE FOR AERONAUTICS

RESEARCH MEMORANDUM

for the

Bureau of Aeronautics, Department of the Navy

FREE-SPINNING-TUNNEL INVESTIGATION OF A $\frac{1}{20}$ -SCALE MODEL

OF THE McDONNELL XF2H-1 AIRPLANE

By Theodore Berman

SUMMARY

A spin-recovery investigation has been conducted in the Langley 20-foot free-spinning tunnel on a $\frac{1}{20}$ -scale model modified to represent the McDonnell XF2H-1 airplane. The project included tests both with tip tanks installed and with the tanks removed.

The results indicated that the recovery characteristics of the airplane would be satisfactory for all loadings by normal recovery technique (full reversal of the rudder, followed 1/2 turn later by movement of the elevator down). The rudder pedal and the elevator stick forces likely to be encountered in a spin should be within the capabilities of the pilot.

INTRODUCTION

The Bureau of Aeronautics, Department of the Navy, requested that the NACA determine the spin and recovery characteristics of the McDonnell XF2H-1 airplane. This airplane incorporates external tip tanks in its design, a trend in recent aircraft. Tests were made to determine the effect of these tanks on the spin and recovery characteristics of the airplane. The XF2H-1 is a development of the McDonnell XF2D-1 dual-jet, single-place, low-wing fighter, a model that was tested previously in the Langley 20-foot free-spinning tunnel (reference 1) and, accordingly, only brief tests were made to evaluate the spin and recovery characteristics of the XF2H-1 airplane without tip tanks installed. The XF2H-1 is heavier than the previous design

~~CLASSIFICATION CANCELLED~~

CLASSIFICATION CANCELLED

and has a different wing section, no horizontal tail dihedral, and a different type of elevator balance. The previously tested model of the XF2D-1 was modified to represent the XF2H-1 and was used for the current tests. The wing was rebuilt and the model reballasted, but the tail changes were not made as it was felt, on the basis of previous experience, that the change in tail dihedral and elevator balance would not appreciably affect the spin or recovery characteristics.

Because of the similarity of the subject airplane and the XF2D-1 airplane, tests of the $\frac{1}{20}$ -scale model of the XF2H-1 airplane were limited to erect spins with tip tanks on and off. Only conditions of tip tank empty and tip tank full were simulated because, on the basis of reference 2, it was felt that, if recoveries were satisfactory for these two loadings, they would also be satisfactory for all intermediate tip-tank loadings.

SYMBOLS

b	wing span, feet
S	wing area, square feet
c	wing or elevator chord at any station along the span
\bar{c}	mean aerodynamic chord, feet
x/\bar{c}	ratio of distance of center of gravity rearward of leading edge of mean aerodynamic chord to mean aerodynamic chord
z/\bar{c}	ratio of distance between center of gravity and fuselage reference line to mean aerodynamic chord (positive when center of gravity is below fuselage reference line)
m	mass of airplane, slugs
I_X, I_Y, I_Z	moments of inertia about X, Y, and Z body axes, respectively, slug-feet ²
$\frac{I_X - I_Y}{mb^2}$	inertia yawing-moment parameter
$\frac{I_Y - I_Z}{mb^2}$	inertia rolling-moment parameter

$\frac{I_Z - I_X}{mb^2}$	inertia pitching-moment parameter
ρ	air density, slug per cubic foot
μ	relative density of airplane $\left(\frac{m}{\rho S b}\right)$
α	angle between fuselage reference line and vertical (approximately equal to absolute value of angle of attack at plane of symmetry), degrees
ϕ	angle between span axis and horizontal, degrees
V	full-scale true rate of descent, feet per second
Ω	full-scale angular velocity about spin axis, revolutions per second
σ	helix angle, angle between flight path and vertical, degrees (For the tests of this model, the average absolute value of the helix angle was approxi- mately 4° .)
β	approximate angle of sideslip at center of gravity, degrees (Sideslip is inward when inner wing is down by an amount greater than the helix angle.)

APPARATUS AND METHODS

Model

The $\frac{1}{20}$ -scale model of the XF2D-1 which was available at the Langley Laboratory was modified to represent the XF2H-1. Three-view drawings of the model as tested and of the airplane are given in figures 1 and 2, respectively, and their dimensional characteristics are listed in table I.

The model was ballasted with lead weights to obtain dynamic similarity to the airplane at an altitude of 15,000 feet ($\rho = 0.001496$ slug/cu ft), and a remote-control mechanism was installed in the model to actuate the controls for recovery tests. Sufficient moments were exerted on the control surfaces during recovery tests to insure their full and rapid movements.

Wind Tunnel and Testing Technique

The model tests were performed in the Langley 20-foot free-spinning tunnel in a manner similar to that described in reference 1. The testing procedure and the technique for obtaining and converting the data to full-scale values were the same as those used in reference 1.

PRECISION

The model test results presented herein are believed to be the true values given by the model within the following limits:

α , deg	± 1
ϕ , deg	± 1
V, percent	± 5
Ω , percent	± 2
Turns for recovery:	
From films	$\pm \frac{1}{4}$
Visual observation	$\pm \frac{1}{2}$

The preceding limits may have been exceeded for certain spins in which it was difficult to control the model in the tunnel because of the high rate of descent or because of the wandering or oscillatory nature of the spin.

Comparison between spin results of airplanes and corresponding models (reference 3) indicates that spin-tunnel results are not always in complete agreement with full-scale spin results. This comparison indicated that approximately 80 percent of the model recovery tests predicted satisfactorily the corresponding airplane turns for recovery, approximately 10 percent underestimated, and approximately 10 percent overestimated them.

Because of the impracticability of exact ballasting of the model and because of small inadvertent changes during testing, the measured weight and mass distribution of the model varied from the true scaled-down values by the following amounts:

Weight, percent	2 low to 1 high
Center-of-gravity location, percent \bar{c}	3 forward to normal
Moments of inertia:	
I_x	2 low to 0
I_y	3 low to 8 low
I_z	5 low to 4 high

The limits of accuracy of the measurements of the mass characteristics are believed to be:

- Weight, percent ±1
- Center-of-gravity location, percent \bar{c} ±1
- Moments of inertia, percent ±5

The controls were set with an accuracy of ±1°.

TEST CONDITIONS

Tests were made to determine the erect spin and recovery characteristics of the model in the tank-off, tank-empty, and tank-full conditions for maximum and intermediate control deflections. The mass characteristics and inertia parameters of the airplane and of the model as tested are shown in table II. The inertia parameters of the XF2H-1 airplane and of the model as tested are plotted in figure 3. As discussed in reference 4, figure 3 can be used as an aid in predicting the effects of controls on the spin and recovery characteristics of the model.

The tail-damping power factor of the XF2H-1 was calculated by the method described in reference 2.

The maximum control deflections used for the current tests were:

- Rudder, deg 20 right, 20 left
- Elevator, deg 25 up, 11 down
- Ailerons, deg 20 up, 20 down

The intermediate control deflections used were:

- Rudder two-thirds deflected, deg $13\frac{1}{3}$
- Elevator two-thirds up, deg $16\frac{2}{3}$
- Elevator one-third down, deg $3\frac{2}{3}$
- Ailerons one-third deflected, deg $\frac{2}{3}$ up, $\frac{2}{3}$ down

RESULTS AND DISCUSSION

The results of spin tests of the model are presented in charts 1 to 3. The model data are presented in terms of full-scale values for

the airplane at a test altitude of 15,000 feet. Because right and left spins are generally similar, data for right spins only are arbitrarily presented.

Tip Tanks Empty

Spin data obtained with the model simulating tip tanks empty are presented in chart 1. The data show that recovery characteristics were satisfactory by rudder reversal alone. It appeared that elevator-up settings were somewhat detrimental and that ailerons full against when the elevator was up was the control configuration that gave the slowest recovery. Even this slowest recovery was, however, on the verge of satisfactory recovery.

Tip Tanks Full

Chart 2 contains the results of spin tests with the fully loaded wing-tip tanks simulated. The data show that simultaneous reversal of the rudder and elevator resulted in satisfactory recoveries but that reversal of the rudder alone did not give satisfactory recoveries. Spins were somewhat oscillatory in pitch and aileron-with-the-spin settings were adverse to recovery.

Intermediate Tank Loading Conditions

As previously indicated, intermediate tank loading conditions were not tested inasmuch as figure 4, which is based on reference 2, indicated that if recoveries are satisfactory from the tank-empty and tank-full conditions, recoveries should also be satisfactory for all intermediate tank-loading conditions by normal use of controls (full rapid rudder reversal followed approximately 1/2 turn later by movement of the stick forward of neutral) as all such loadings fall in a satisfactory region.

Aerodynamic Effect of Tanks

Unpublished data have indicated that external fuel tanks have little aerodynamic effect on spin and recovery characteristics and that any effect of installation of tanks is primarily due to the mass changes accompanying the tank installation.

Tank-Off Condition

Data obtained from spin tests of the model with tanks off are presented in chart 3. These data were obtained at the end of the test program with this model and, because of damage during testing, the model gave asymmetrical results for right and left spins. Inasmuch as the model results previously obtained for the tank-on conditions had been symmetrical, it was felt that an average of right and left model spin test results would give a proper interpretation of the expected full-scale results with tanks off. Accordingly, the averages of the results are presented and they indicate satisfactory recoveries at this loading by reversal of the rudder.

Jettisoning of Wing-Tip Tanks

If any difficulty in recovery is encountered in spins with the wing-tip tanks installed, the tanks should be jettisoned and recovery attempted again by normal recovery technique. Spin-tunnel experience has indicated that the jettisoned tanks will fall clear of the airplane.

Recommended Recovery Technique

On the basis of the test results, the use of the following spin-recovery technique is recommended for all loadings:

The stick should be held full back and laterally neutral. The rudder should be reversed fully and rapidly against the spin followed, approximately 1/2 turn later, by movement of the stick briskly well forward of neutral while keeping the ailerons neutral. In moving the stick forward, care should be exercised to avoid excessive rates of acceleration in the ensuing recovery dive.

Control Forces

The discussion so far has been based on control effectiveness without regard to the forces required to move the controls. Sufficient force must be applied to the airplane controls to move them similarly in order for the model and airplane results to be comparable. Tests in reference 1 showed that the rudder-pedal force of the XF2D-1 in a spin would be within the capabilities of the pilot. It is therefore felt that the rudder-pedal force of the XF2H-1 in a spin will also be within the pilot's capabilities inasmuch as the two airplanes have similar vertical tails. The elevator stick force was calculated by the method of reference 5 assuming unbalanced surfaces. The calculations are therefore believed to be somewhat conservative. It

was indicated that the elevator stick force would be of the magnitude of 100 pounds, which is somewhat high but should be within the pilot's capabilities.

CONCLUSIONS

Based on the results of spin tests of a $\frac{1}{20}$ -scale model representing the McDonnell XF2H-1 airplane, the following conclusions are made regarding spin and recovery characteristics:

1. Recovery characteristics of the airplane will be satisfactory for all loading conditions if recovery is attempted by normal recovery technique, that is, the rudder is reversed fully and rapidly and approximately 1/2 turn later the elevator is moved down while keeping the ailerons neutral.

2. The control forces encountered in the spin should be within the pilot's capabilities.

Langley Aeronautical Laboratory
National Advisory Committee for Aeronautics
Langley Air Force Base, Va.

Theodore Berman
Theodore Berman

Aeronautical Research Scientist

Approved:

Thomas A. Harris

Thomas A. Harris
Chief of Stability Research Division

JMS

REFERENCES

1. Stone, Ralph W., Jr., and Berman, Theodore: Free-Spinning-Tunnel Tests of a $\frac{1}{20}$ -Scale Model of the McDonnell XF2D-1 Airplane - TED No. NACA 2393. NACA MR L6F24, Bur. Aero., June 1946.
2. Neihouse, Anshel I., Lichtenstein, Jacob H., and Pepoon, Philip W.: Tail-Design Requirements for Satisfactory Spin Recovery. NACA TN 1045, 1946.
3. Seidman, Oscar, and Neihouse, A. I.: Comparison of Free-Spinning Wind-Tunnel Results with Corresponding Full-Scale Spin Results. NACA MR, Dec. 7, 1938.
4. Neihouse, A. I.: A Mass-Distribution Criterion for Predicting the Effect of Control Manipulation on the Recovery from a Spin. NACA ARR, Aug. 1942.
5. Sears, Richard I., and Hoggard, H. Page, Jr.: Characteristics of Plain and Balanced Elevators on a Typical Pursuit Fuselage at Attitudes Simulating Normal-Flight and Spin Conditions. NACA ARR, March 1942.

TABLE I.- DIMENSIONAL CHARACTERISTICS OF THE McDONNELL XF2H-1
AIRPLANE AND THE $\frac{1}{20}$ -SCALE MODEL TESTED

	Model (Full-scale values)	Airplane
Over-all length, ft	39.0	40.0
Wing:		
Span, ft	41.5	41.5
Area, sq ft	294.0	294.0
Section, wing-fold	NACA 65 ₁ -212	NACA 65 ₁ -212
Incidence, deg	0	-0.5
Aspect ratio	5.9	5.9
Dihedral, deg	6.0	3.0
Mean aerodynamic chord, in.	88.4	88.4
Leading edge of \bar{c} aft of leading edge of root chord, in.	0	0
Ailerons:		
Area aft hinge line, sq ft	18.6	18.8
Span, percent b/2	34.6	34.6
Horizontal tail surfaces:		
Total area, sq ft	59.2	69.9
Span, ft	15.9	18.0
Elevator area aft hinge line, sq ft	15.7	17.7
Distance from normal center of gravity to elevator hinge line, ft	18.6	18.8
Dihedral, deg	15.0	0
Vertical tail surfaces:		
Total area, sq ft	39.8	39.8
Rudder area aft hinge line, sq ft	10.2	10.2
Distance from normal center of gravity to rudder hinge line, ft	20.3	20.3
Tail-damping power factor	0.000528	0.000463



TABLE II.- MASS CHARACTERISTICS AND MASS PARAMETERS POSSIBLE FOR THE
MCDONNELL XF2H-1 AIRPLANE AND TESTED ON THE SIMULATED $\frac{1}{20}$ -SCALE MODEL

[Moments of inertia are about center of gravity, model values converted to full scale]

Number (same as fig. 3)	Loading	Weight (lb)	μ		Center-of- gravity location		Moments of inertia (slug-ft ²)			Mass parameters		
			Sea level	15,000 feet	x/\bar{c}	z/\bar{c}	I_X	I_Y	I_Z	$\frac{I_X - I_Y}{mb^2}$	$\frac{I_Y - I_Z}{mb^2}$	$\frac{I_Z - I_X}{mb^2}$
Airplane values												
1	Clean condition	16,773	18.0	28.5	0.240	0.080	16,413	24,348	38,380	-89×10^{-4}	-157×10^{-4}	245×10^{-4}
2	Tip tanks on and empty	17,173	18.3	29.1	.240	.080	22,252	24,348	44,219	-23	-215	238
3	Tip tanks on and full	19,573	20.9	33.2	.240	.080	56,564	25,288	78,995	297	-510	213
Model values												
1	Clean condition	16,748	17.9	28.4	.225	.080	16,162	24,346	38,737	-91×10^{-4}	-161×10^{-4}	252×10^{-4}
2	Tip tanks on and empty	16,942	18.1	28.7	.210	.084	22,334	22,753	42,918	-5	-222	226
3	Tip tanks on and full	19,778	21.1	33.6	.237	.070	55,892	26,162	80,076	280	-507	228



CHART 1.- SPIN AND RECOVERY CHARACTERISTICS OF THE SIMULATED $\frac{1}{20}$ -SCALE MODEL OF THE
McDONNELL XF2H-1 AIRPLANE WITH THE WING-TIP TANKS ON AND EMPTY

[Loading point 2 on table II and figure 3; flaps neutral; cockpit closed; recovery attempted by rapid full rudder reversal except as noted (recovery attempted from, and steady-spin data presented for, rudder-with spins); right erect sping]

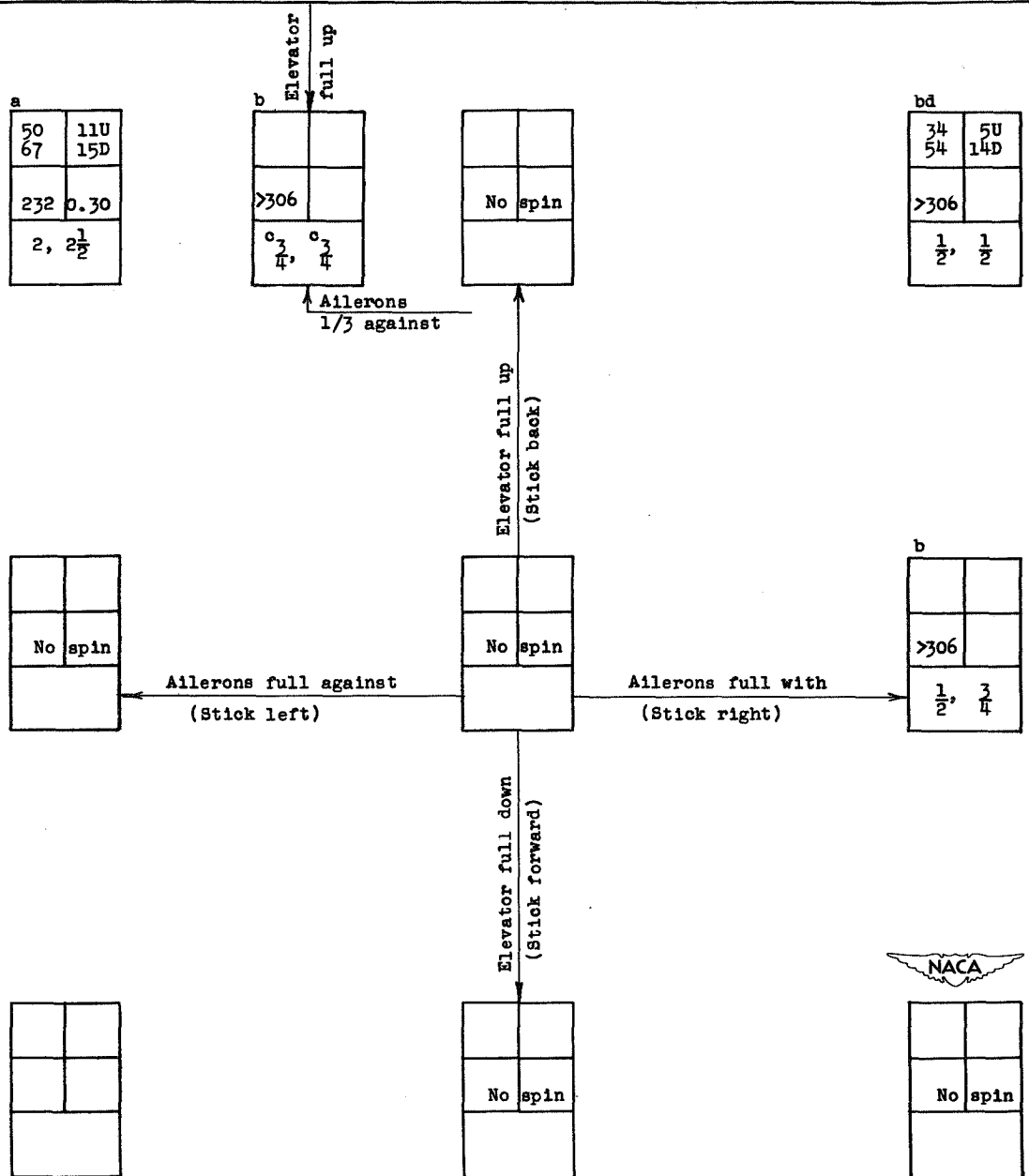

^aSpin oscillatory in roll, pitch, and yaw. Range of values or average value given.

^bRecovery attempted before model in final, steeper attitude.

^cRecovery attempted by reversal of rudder from full with to 2/3 against the spin.

^dWandering, whipping spin.

Model values converted to corresponding full-scale values.
U inner wing up
D inner wing down

α (deg)	ϕ (deg)
V (fps)	Ω (rps)
Turns for recovery	

CHART 2.- SPIN AND RECOVERY CHARACTERISTICS OF THE SIMULATED $\frac{1}{20}$ -SCALE MODEL OF THE
McDONNELL XF2H-1 AIRPLANE WITH THE WING-TIP TANKS FULLY LOADED

[Loading point 3 on table II and figure 3; flaps neutral; cockpit closed; recovery attempted by rapid rudder reversal except as noted (recovery attempted from, and steady-spin data presented for, rudder-with spins); right erect spins]

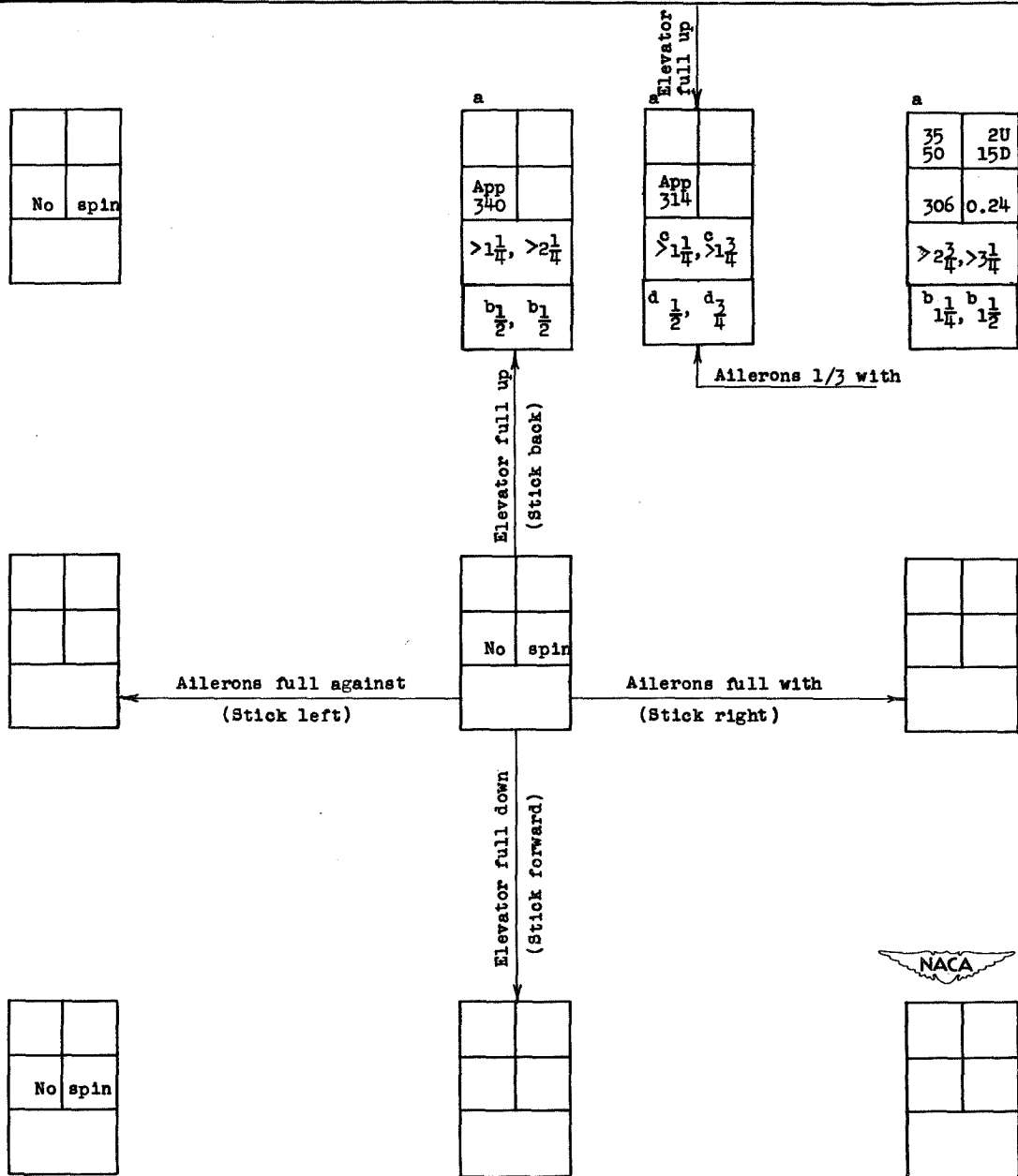

- ^aWandering spin, oscillatory in pitch.
- ^bRecovery attempted by simultaneous full reversal of the rudder and elevator.
- ^cRecovery attempted by reversal of rudder from full with to 2/3 against the spin.
- ^dRecovery attempted by simultaneous reversal of the rudder from full with to 2/3 against the spin and the elevator from full up to 1/3 down.

Model values converted to corresponding full-scale values.
U inner wing up
D inner wing down

α (deg)	ϕ (deg)
V (fps)	Ω (rps)
Turns for recovery	

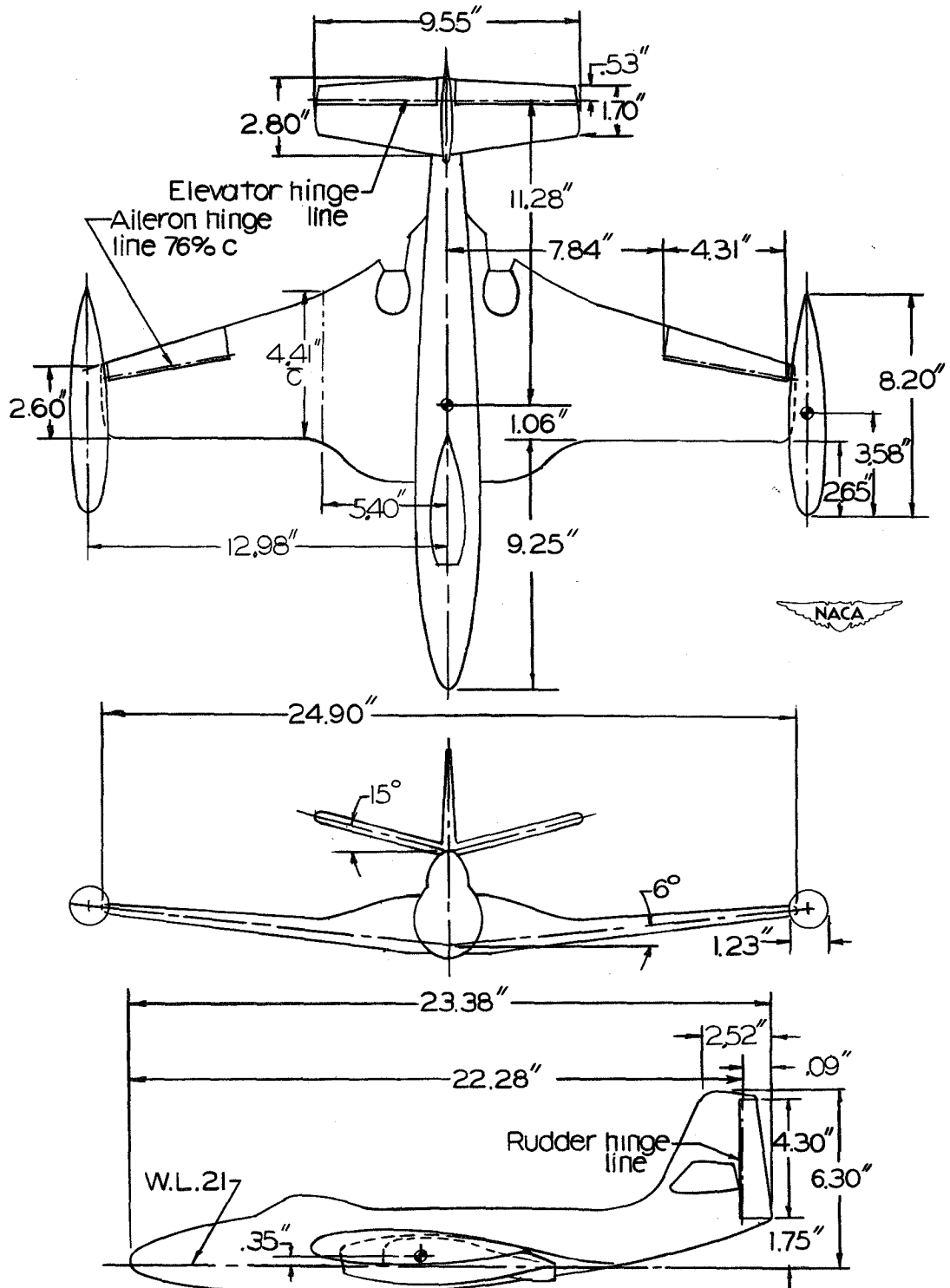

Figure 1. Drawing of the simulated $\frac{1}{20}$ scale model of the McDonnell XF2H-1 airplane as tested in the free-spinning tunnel. Center of gravity is indicated for the empty tip-tanks loading.

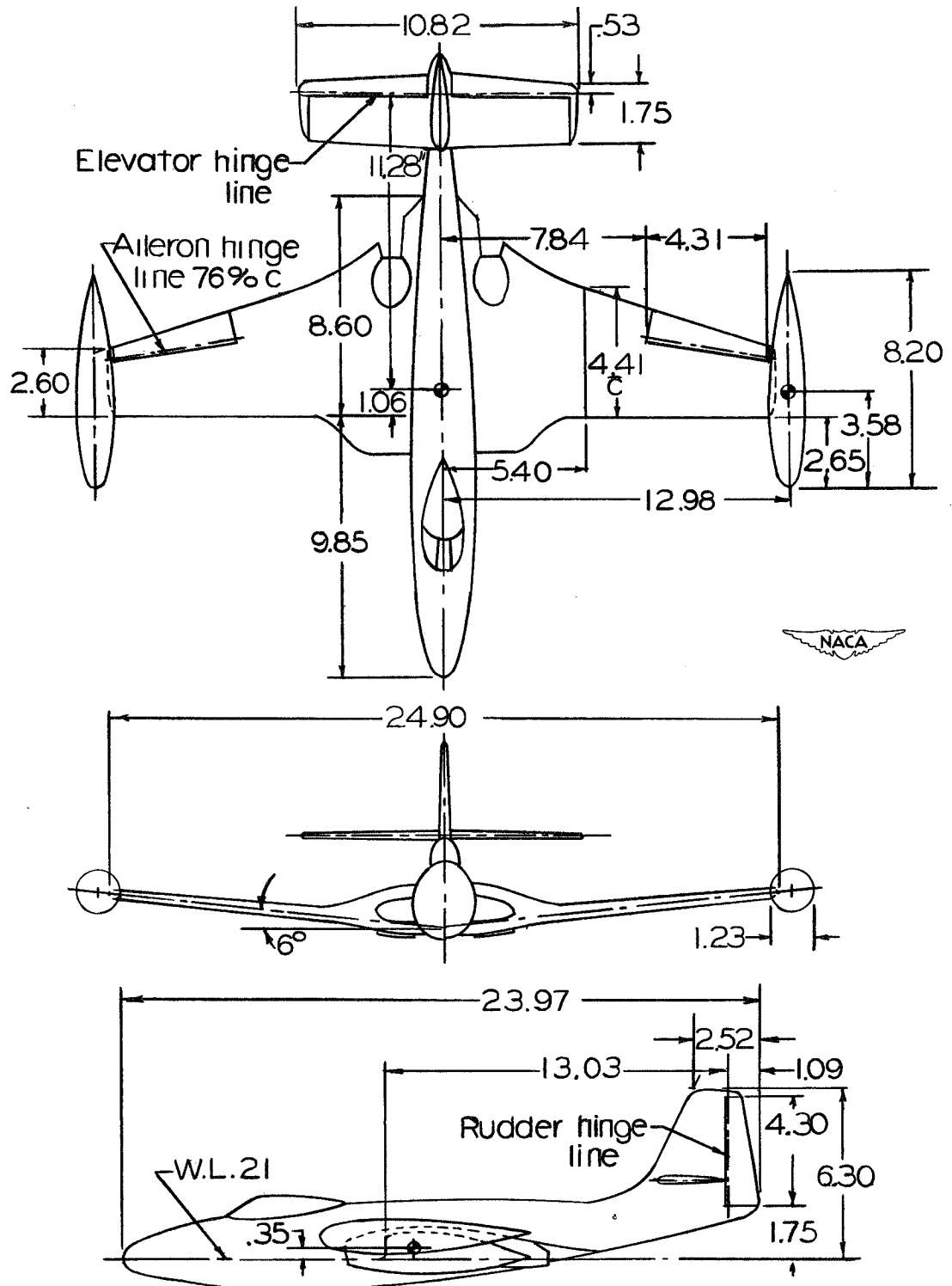

Figure 2.- Three-view drawing of the McDonnell XF2H-1 airplane. Dimensions are for a $\frac{1}{20}$ -scale model in inches. Center of gravity is shown for the empty tip-tanks loading.

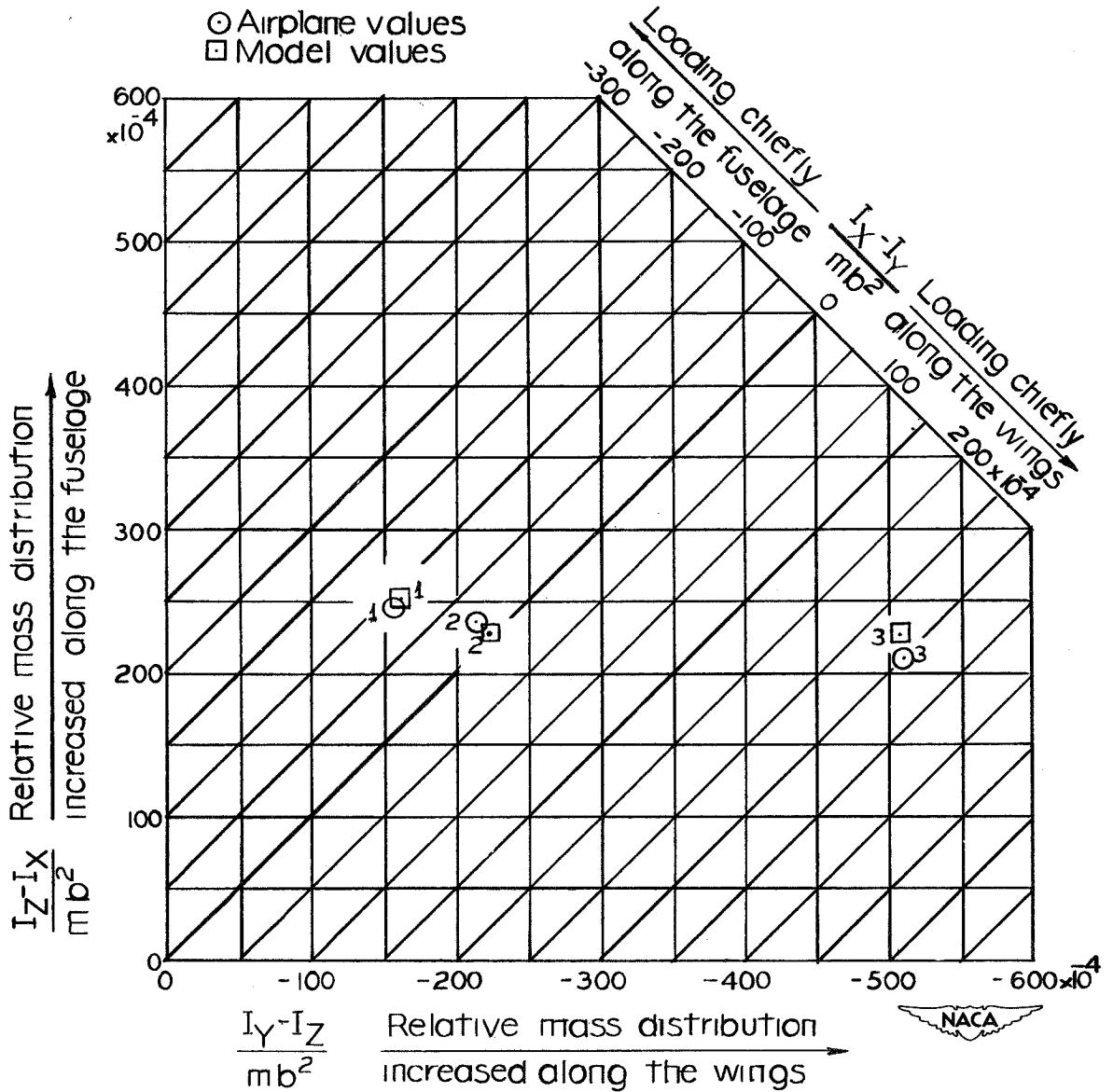

Figure 3.- Mass parameters possible on the McDonnell XF2H-1 airplane and tested on the simulated $\frac{1}{20}$ -scale model.

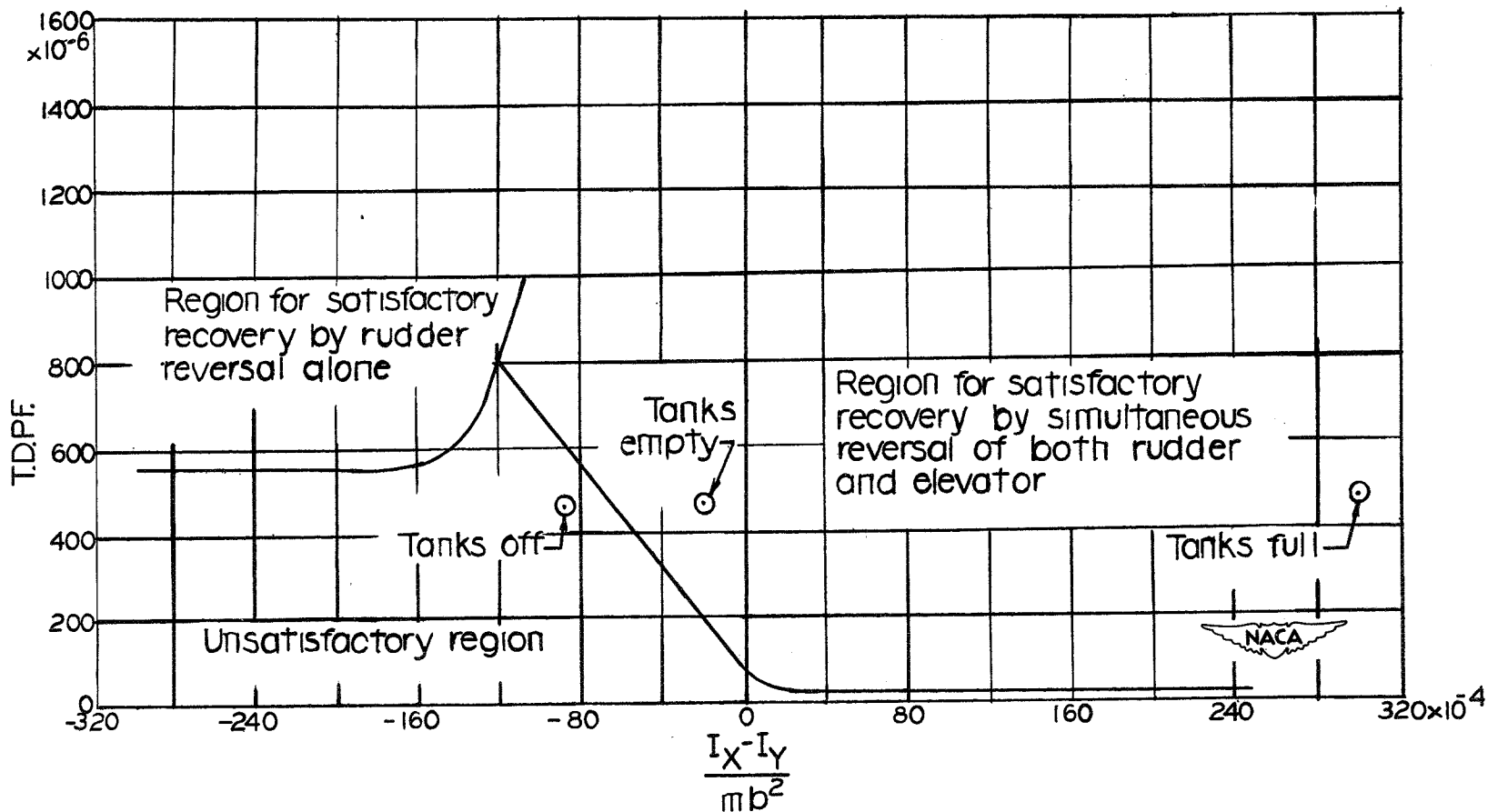

Figure 4.-Spin design requirements.