

NASA Flight Operations of Ikhana and Global Hawk



Herman Posada
NASA Dryden Flight Research
Center
July 2009





Western States Fire Mission Modifications

IKHANA

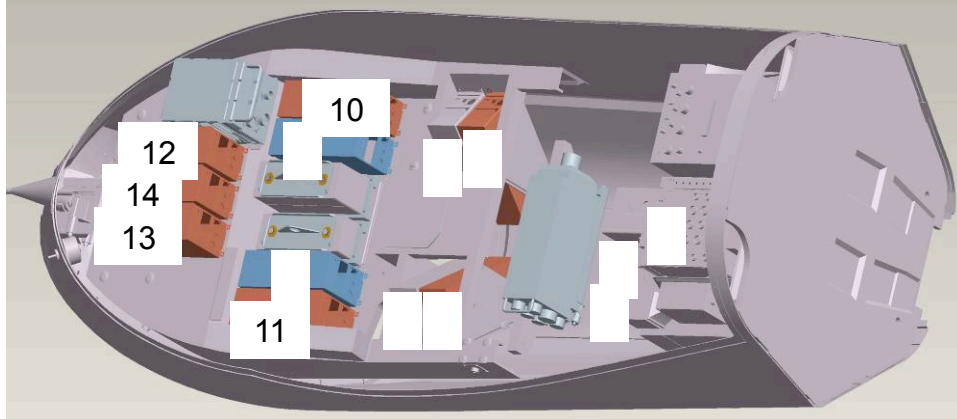

Back-up battery power increased to 3 hours

Wiring connections from pod to power distribution, GPS antenna, and SatCom system

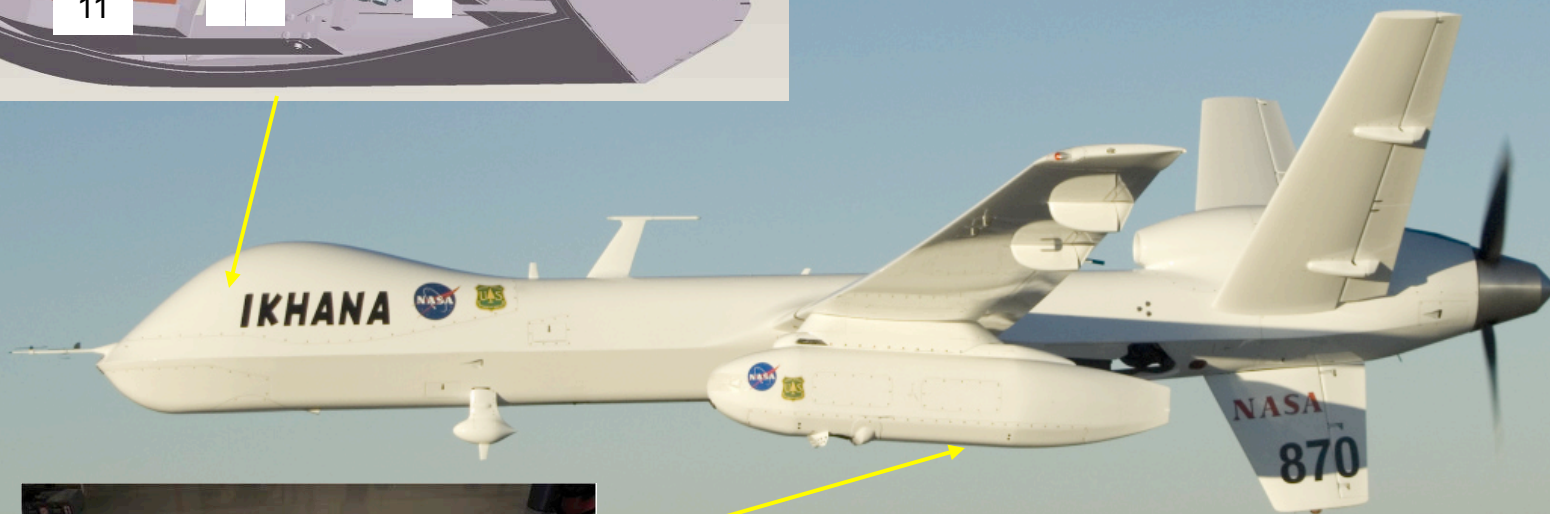

Infrared Wildfire Scanner



Ground Systems

IKHANA

- Mobile Ground Control Station
 - Dual pilot control station
 - Electronic navigation charts
 - Weather
 - 6 Engineering/Science workstations
 - Range safety workstation
 - Intercom system throughout
 - Overhead mission displays
 - Telephones
 - Remote video from aircraft start-up/shut-down site
 - Downlink video and data recording
- Mobile 2.4m Ku SatCom Antenna
 - Dual redundant receiver/transmitters

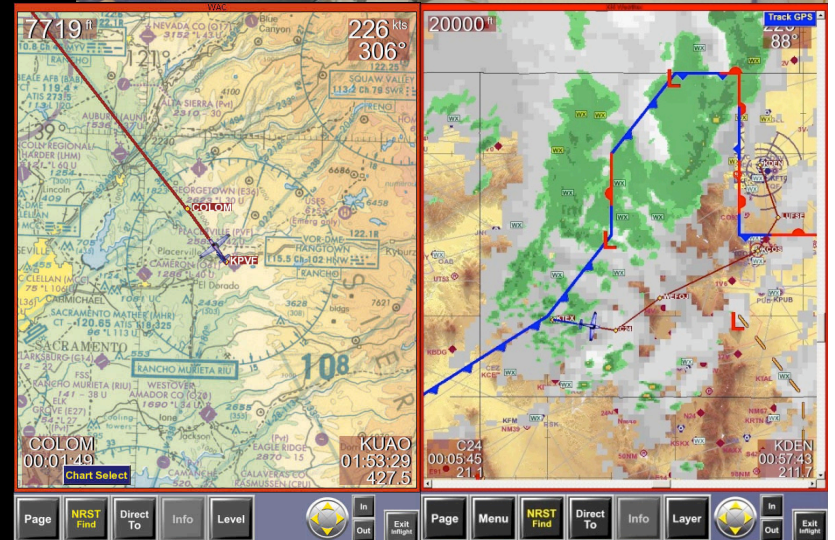



2007 Western States Fire Mission Objectives

IKHANA

Mission

- Demonstrate capabilities of UAS to overfly and collect sensor data on widespread fires throughout Western US.
- Demonstrate long-endurance mission capabilities (20-hours+).
- Image multiple fires (greater than 4 fires per mission), to showcase extendable mission configuration and ability to either linger over key fires or station over disparate regional fires.
- Demonstrate new UAV-compatible, autonomous sensor for improved thermal characterization of fires.
- Provide automated, on-board, terrain and geo-rectified sensor imagery over OTH satcom links to national fire personnel and Incident commanders.
- Deliver real-time imagery to (within 10-minutes of acquisition).
- Demonstrate capabilities of OTS technologies (GoogleEarth) to 'serve' and display mission-critical sensor data, coincident with other pertinent data elements to facilitate information processing (WX data, ground asset data, other satellite data, R/T video, flight track info, etc).



Operations Concept

IKHANA

How to fly the mission

- Chase aircraft required below 18k in the U.S. National Airspace (NAS)
- Air traffic control (ATC) used for collision avoidance above 18,000 ft
- NASA Dryden uses restricted airspace to climb to cruise altitude before exiting into the NAS
- Since Ikhana not qualified for Reduced Vertical Separation Minima (RVSM), operations are limited to 18,000 ft to FL 290 or above FL 410
- Transponder and radio communication required

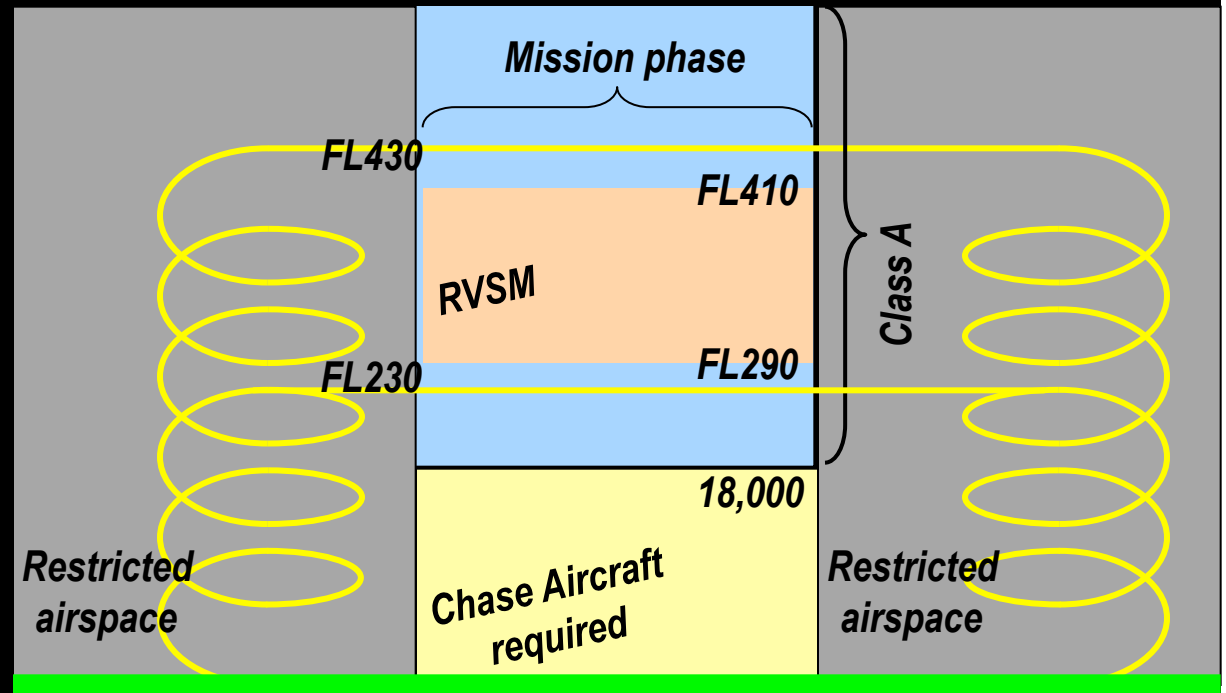

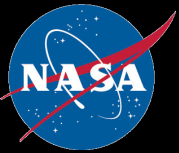

Certificate of Authorization (COA) Boundary Request

IKHANA

3 Operational Zones

Each zone includes no more than 3 ARTCC areas

639000 sq. miles

From Mexican border to the Canadian border

States covered
California, Nevada,
Oregon, Washington,
Utah, Montana,
Wyoming, Idaho





Range Safety Protection Zones

IKHANA

KEEP-OUT ZONES

Defined and “Owned”
by DFRC Range Safety

Can be changed or
updated before or
during flight with
concurrence of a DFRC
Range Safety Officer
(RSO)

 **NOMINAL
AIRCRAFT**

 **UNHEALTHY
AIRCRAFT**

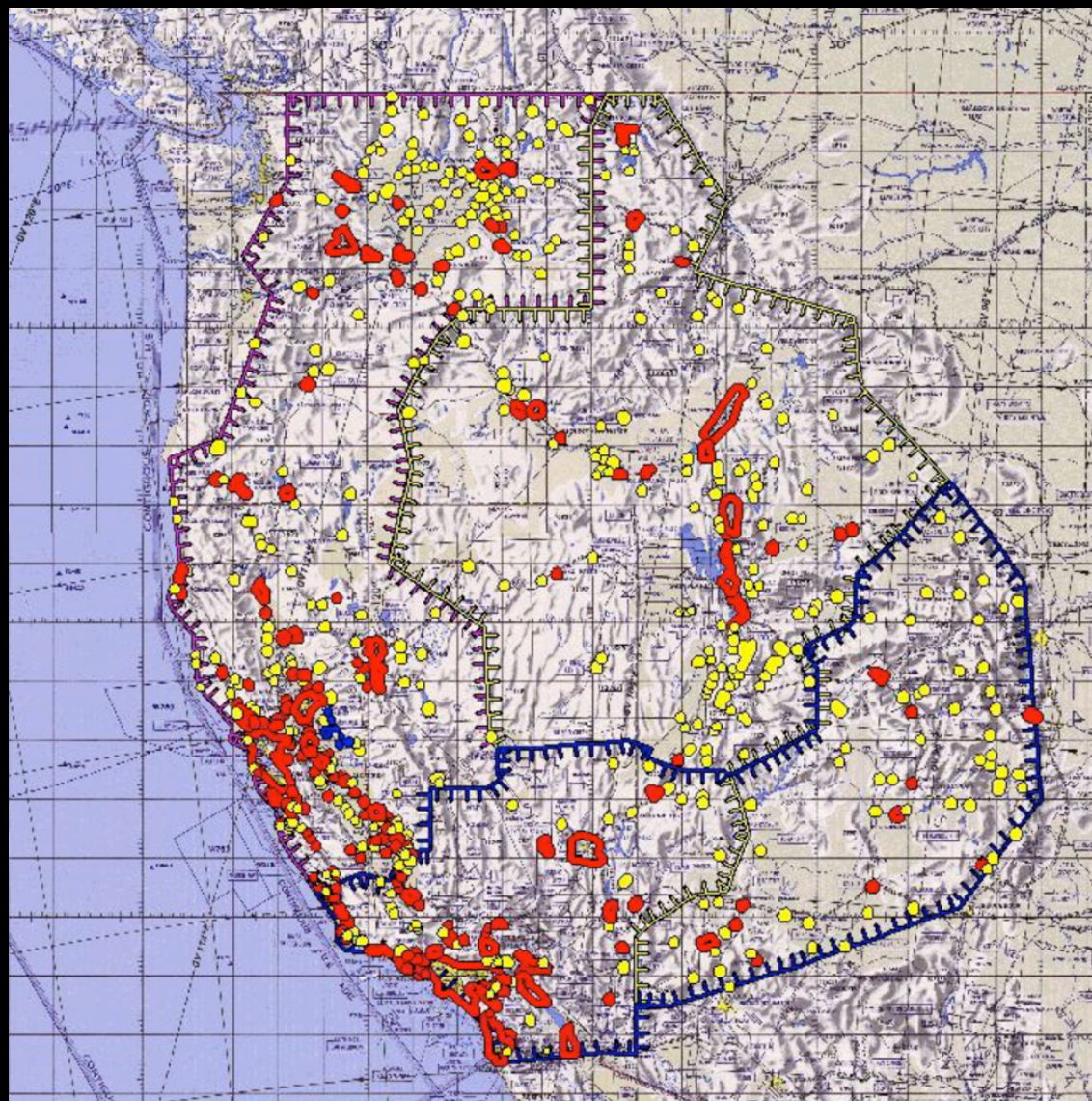



Routes A, B, C

IKHANA

Defined Routes for each Zone

Over/near forested areas

Avoid population areas

Avoid directly above mountains when possible

- Weather when lost link

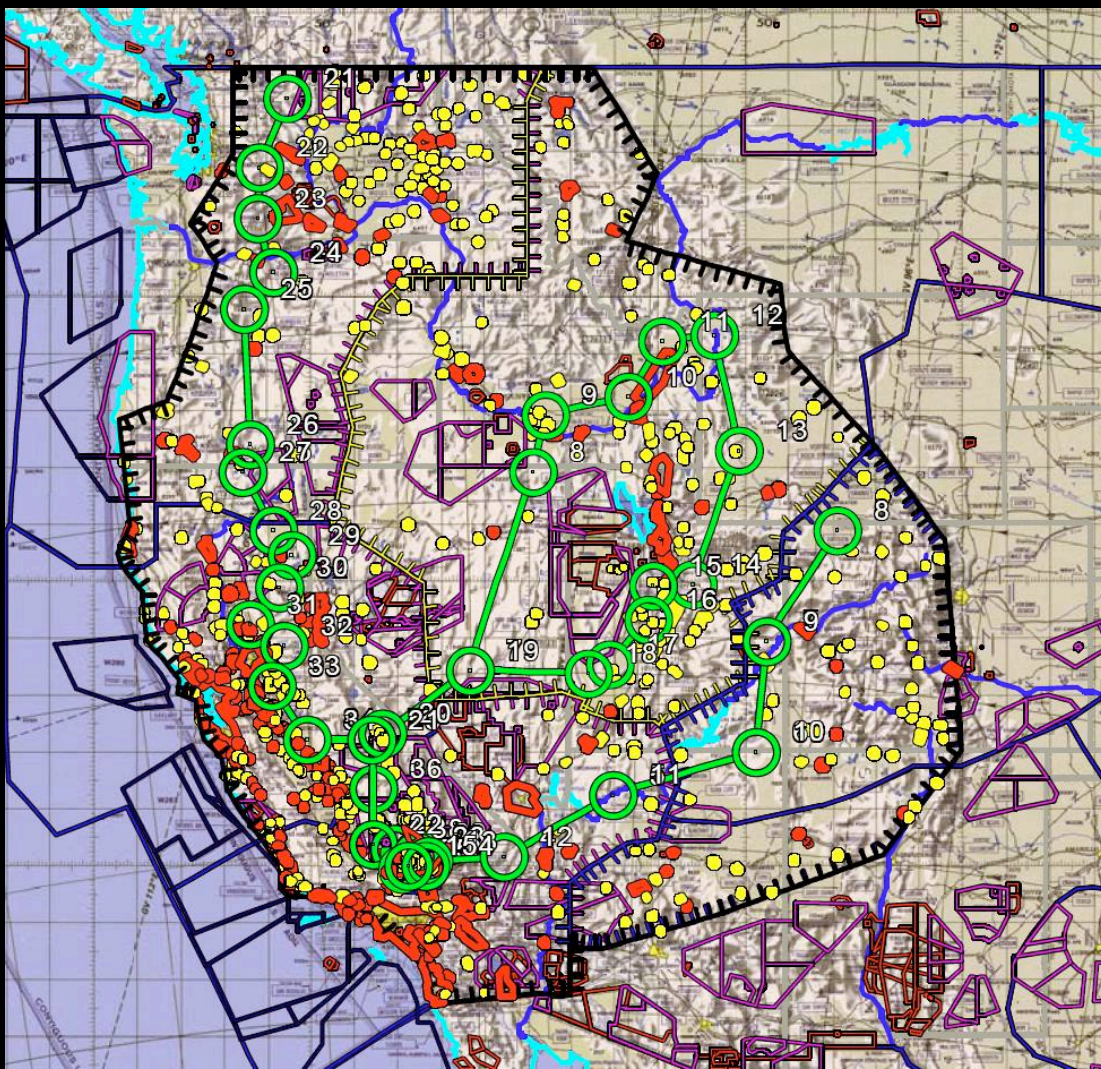



Primary Emergency Landing Sites

IKHANA

Radius =400 nmi

**Minimum Range
on Battery
Power**

**Aircraft has
single generator**

**Landing
agreements
negotiated with
each site**



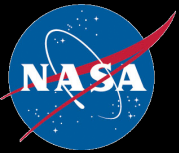

Secondary Emergency Landing Sites

IKHANA

Radius=50 nmi (minimum glide from 23,000 ft)

Over 280 sites identified

Categorized Green, Yellow, Purple, Red by pilots

Selected in unpopulated areas. Abandoned runways, dry lakebeds, flat ground, ditch areas

Primary purpose is to protect public

Actively managed during each mission

“Owned” by DFRC Range Safety and changeable

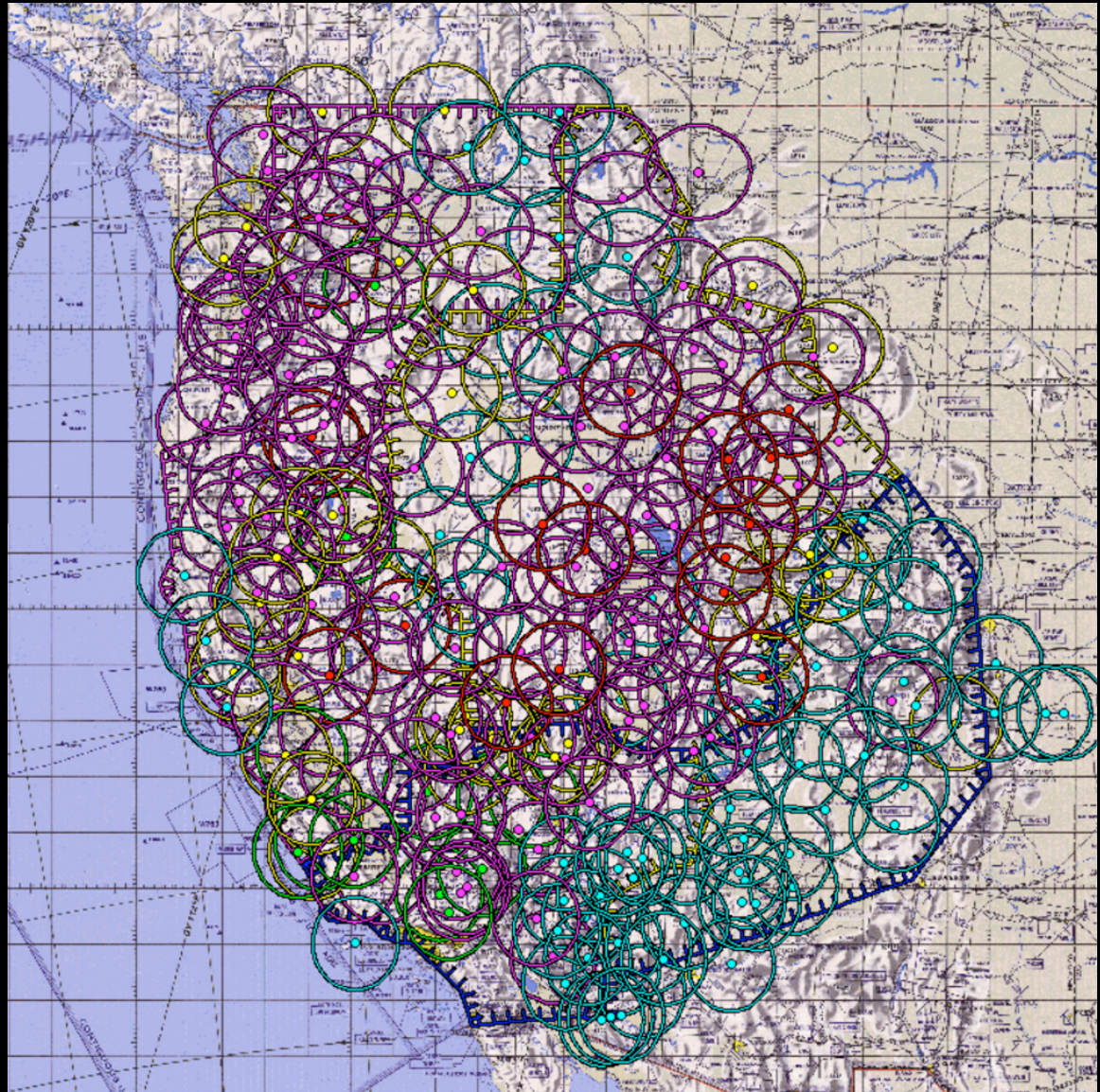



Mac Gillivray

Near Adelaida, CA

(Abandoned landing strip)

35° 38' 39.52" N

120° 51' 01.37" W

Elev. 1454 ft

Paved

Length: 3000 ft

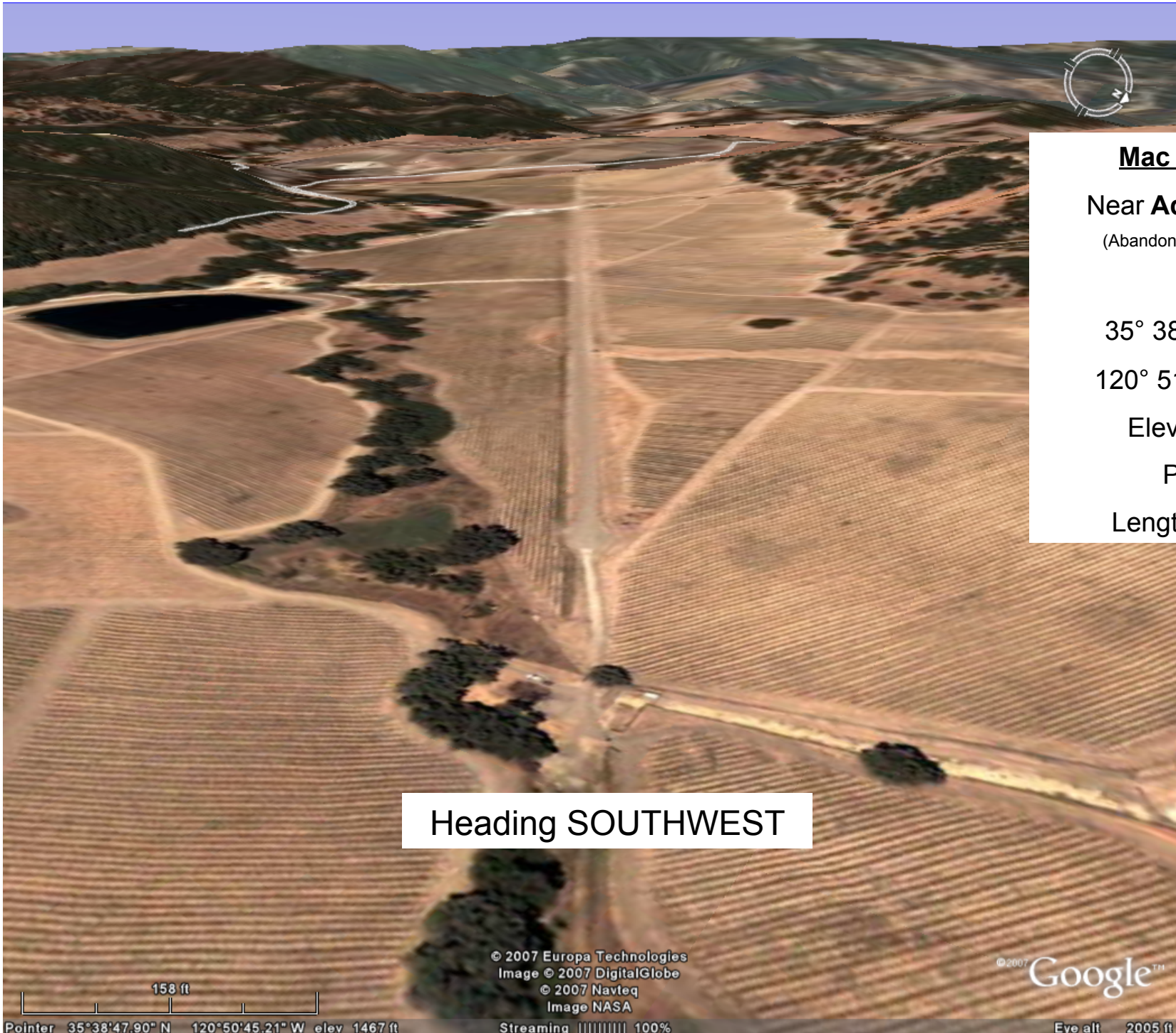

Mac Gillivray

Near **Adelaida, CA**

(Abandoned landing strip)

35° 38' 39.52" N

120° 51' 01.37" W

Elev. 1454 ft

Paved

Length: 3000 ft

Heading SOUTHWEST

© 2007 Europa Technologies
Image © 2007 DigitalGlobe
© 2007 Navteq
Image NASA

©2007 Google™



Pointer 35°38'47.90" N 120°50'45.21" W elev. 1467 ft

Streaming 100%

Eye alt 2005 ft



Chart Case Professional

IKHANA

CHART CASE

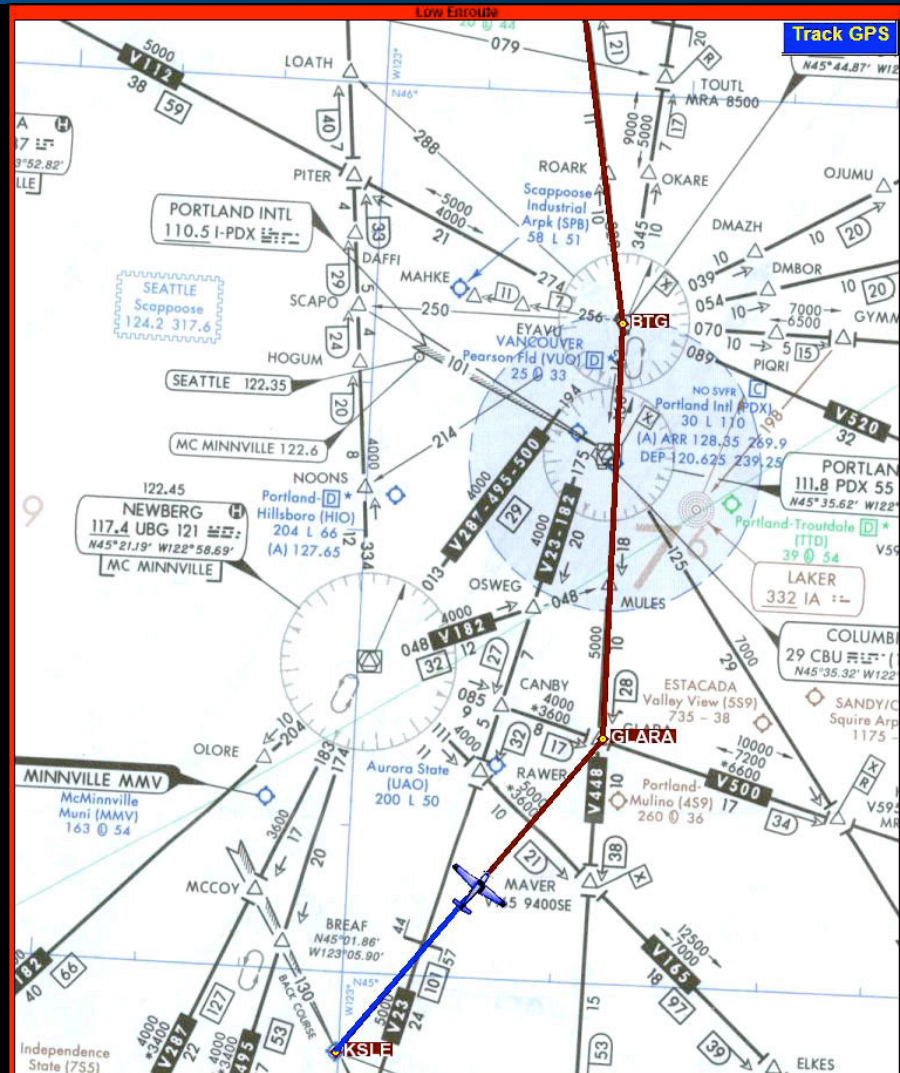

Navigation controls for the topographic chart, including buttons for Page, NRST Find, Direct To, Info, Level, and a directional pad. Additional controls include In, Out, and Exit Inflight.

Navigation controls for the enroute chart, including buttons for Page, Menu, NRST Find, Direct To, Info, Layer, and a directional pad. Additional controls include In, Out, and Exit Inflight.

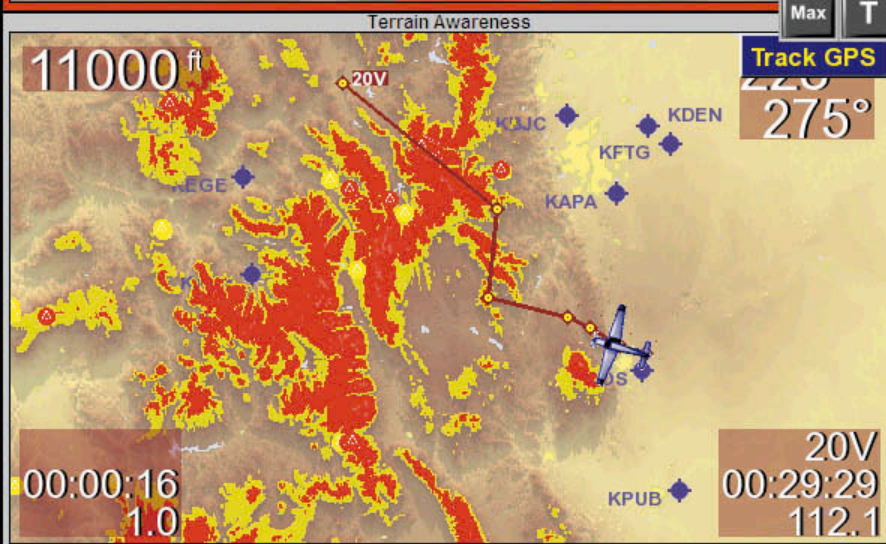

Chart Case Professional

IKHANA

CHART CASE WITH XM WEATHER

HITS - CAUTION - GPS Derived data, No Pitch or Bank Information - CAUTION - HITS



Navigation controls: Page, NRST Find, Direct To, Info, Layer, In, Out, Exit Inflight.

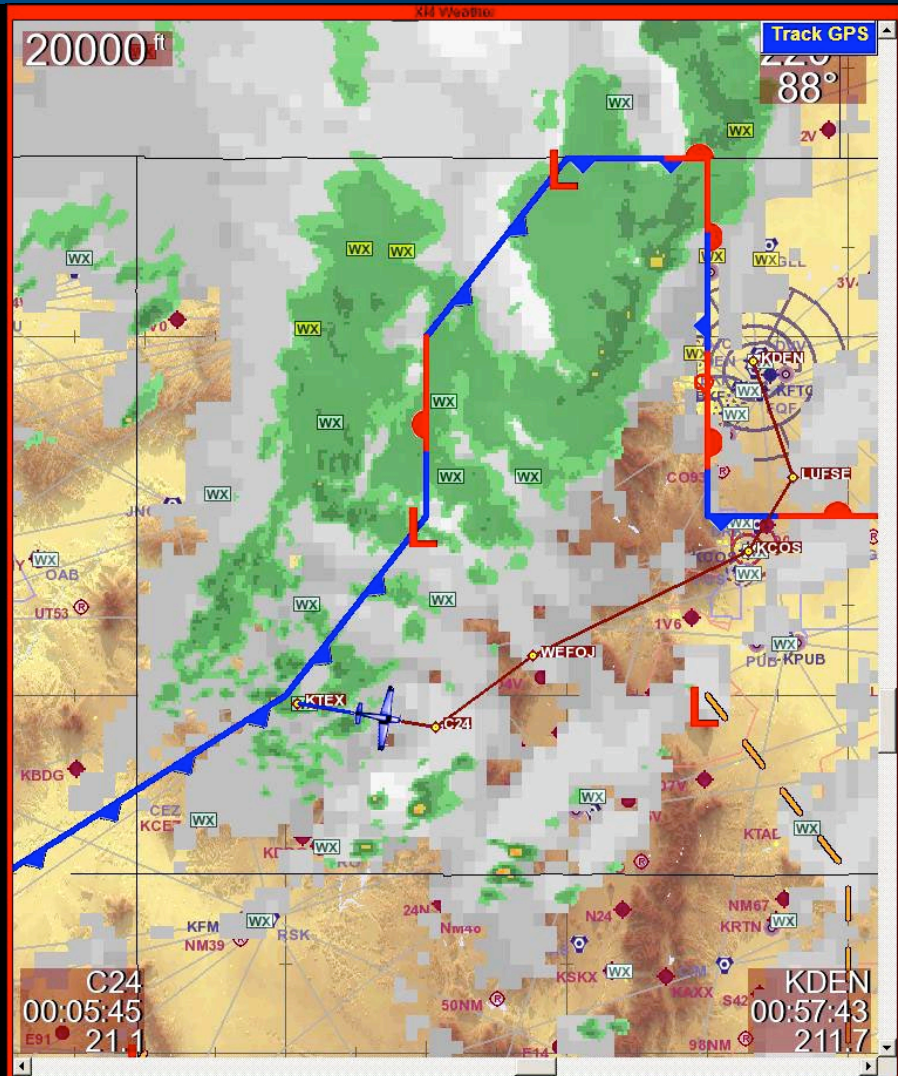

Navigation controls: Page, Menu, NRST Find, Direct To, Info, Layer, In, Out, Exit Inflight.



COA Application Provisions

IKHANA

- Only for “4-5” flights, 1 per week
 - But... wildfire emergencies could occur that would require quick turnaround and possibly more flights
- Stay 5 nm away from Zone boundaries
- Stay 10 nm away from International borders (Canada, Mexico)
- Public Use aircraft
- NASA self-certifies for airworthiness



COA: Special Provisions

IKHANA

- Remain within 75 nm of 'backbone' route
- 3 business day mission notification to FAA
 - With "specific routes" identified
- IFR Flight Plan submitted 24 hours in advance
- Flight Plan
 - Point to point is acceptable
 - Application was submitted as a "hub and spoke"
 - in FRD format (fix-radial-distance)
 - No more than 48 elements (fixes + loiter times)
- Mission Planning telecon with affected ATC Centers 24 hours prior to mission



COA: Special Provisions (con't)

IKHANA

- No flight into forecasted “moderate or severe” turbulence
- No flight in area where convective SIGMET has been issued
- No flight in area of known or forecast icing
- No flight in area of affected by GPS testing, solar storms or RAIM outages
- Contact list maintained for all ATC Centers and Ikhana GCS



COA: Special Provisions (con't)

IKHANA

- Lost link procedure
 - Maintain altitude
 - Continue on filed flight plan (the route) for 15 min
 - Does not mean “keep going straight ahead for 15 minutes”
 - If in a loiter area, stay in there for at least 15 minutes
 - Squawk 7600
 - Aircraft will turn right, if it has to retrace the flight plan
 - Aircraft will return to R-2508/R-2515 the way it came out (usually)



Approved COA Area

IKHANA

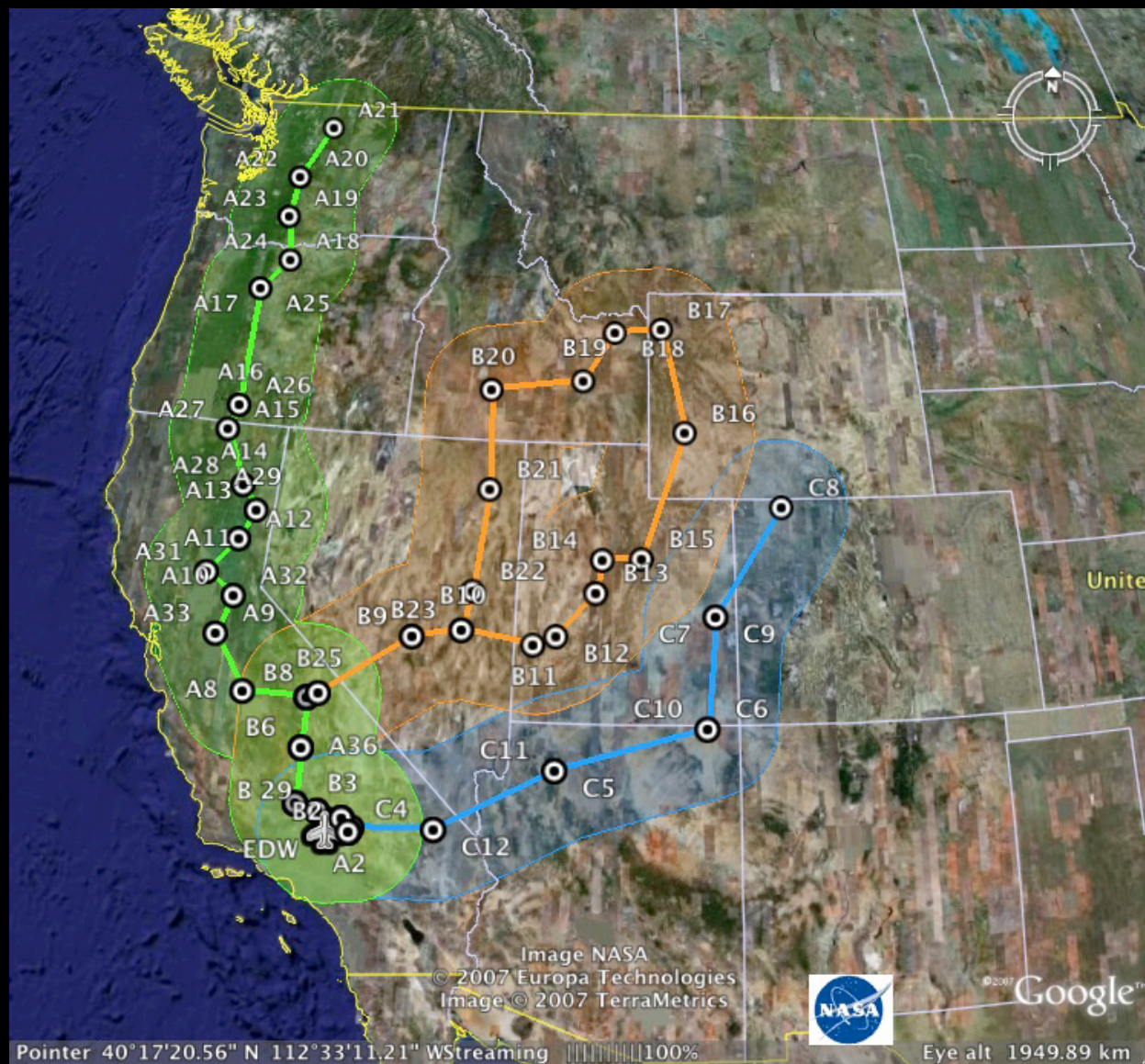

Ikhana Western States Fire Missions 2007

1st Fire Mission 8/16/07
9.5 hours
1400 nmi

2nd Fire Mission 8/29/07
16.1 hours
2500 nmi

3rd Fire Mission 9/7/07
20 hours
3200 nmi

4th Fire Mission 9/27/07
10 hours
1800 nmi

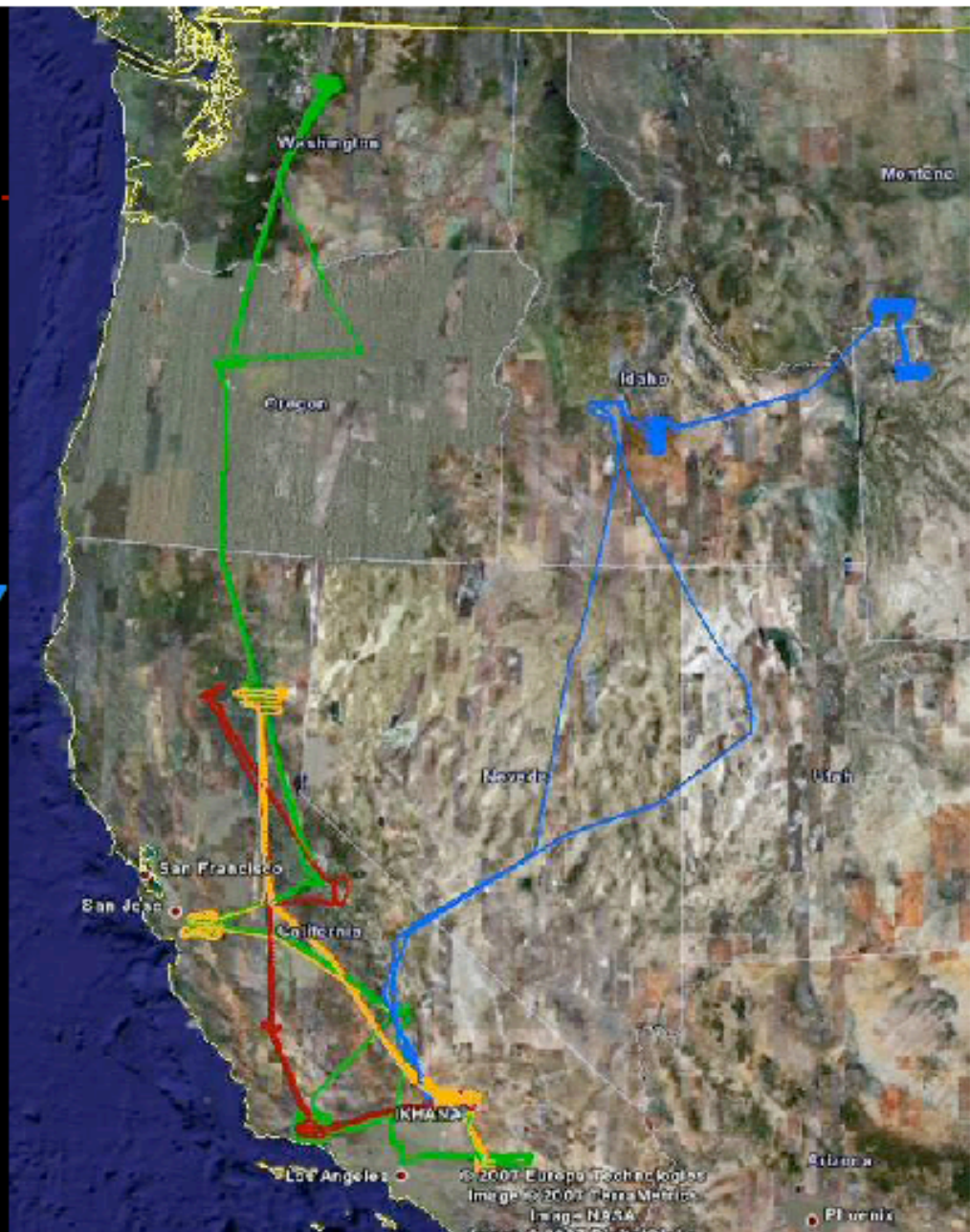



WSFM #1 - Zaca Fire

IKHANA

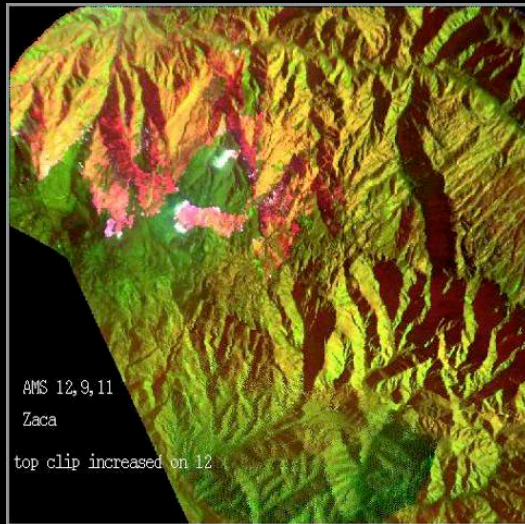

- Delivered real-time data to Incident Command on Zaca; well received, clamored for more data
- Director, Fire and Aviation Management, USFS, R5: “I was standing in Area Command for the Zaca incident on the morning of the first flight. Our conversation surrounded the "fog of war" existing due to an inversion on the southeast corner of the fire... the incident management teams did not know where the fire was, and that information was critical to modify their strategy and initiate action. The intel provided by the UAV, real time and geospatially oriented, answered that critical question and saved precious hours. Yes, indeed, it was a success. I look forward to the eventual inclusion of this technology and platform as a standard component of our arsenal. The reduction in cost, exposure to air crews currently flying infrared sorties, and the real time and extended nature of the intel provided are all advantageous to our mission. Thank you and all those with the foresight before who saw the potential and reached out in cooperation to make it a reality.”

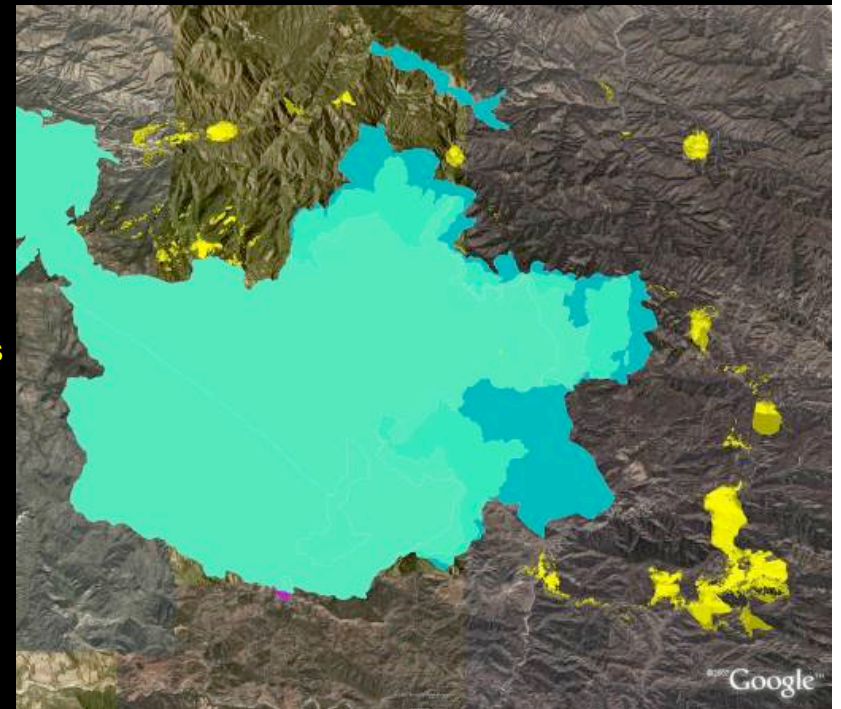

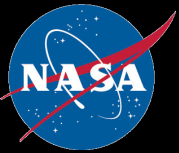

WSFM #2 - Aug 29-30, 2007

IKHANA

- Real-time ATC routing around poor weather saved the mission
- Collected and transmitted real-time fire data on eight fires spread through CA (Jackrabbit), ID (Trapper Ridge, Castle Rock, Granite Creek, and Hardscrabble), MT (WH Fire), and WY (Columbine Fire).
- Made repeat passes over each, spending most time over Castle Rock, as this was a high priority fire for US, threatening Ketchum and Sun Valley, ID.
- Delivered real-time data to Incident Command on Castle Rock; used for operations and redeployment of resources on the fire based on our data.
- Collected coincident UAV data with a MODIS satellite data overpass on castle Rock...major science accomplishment
- Tremendous amount of national publicity for NASA, USFS, and FAA.

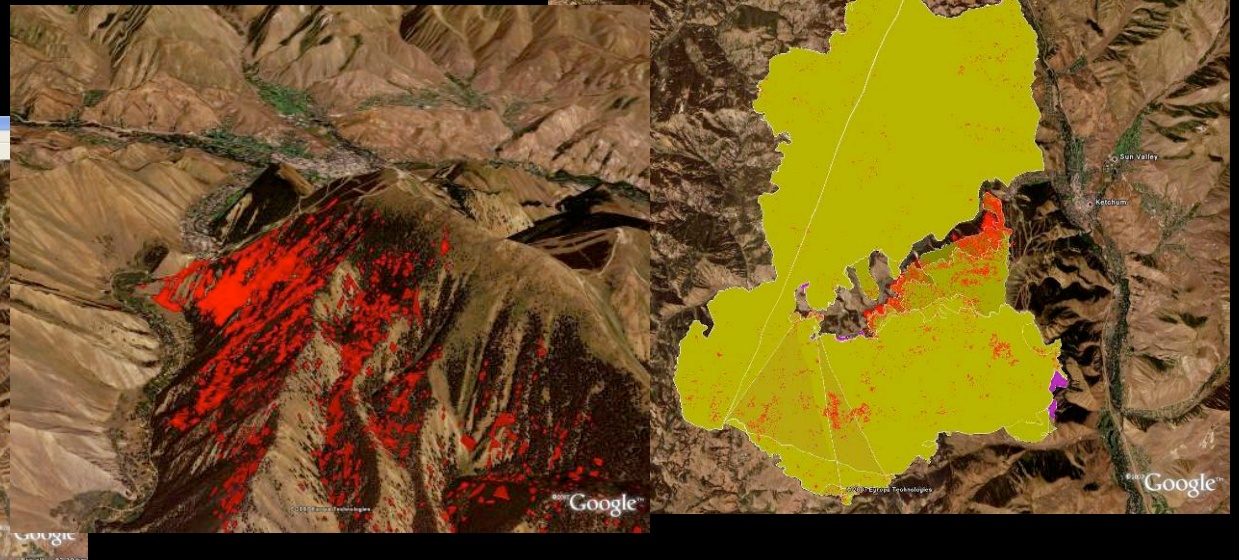
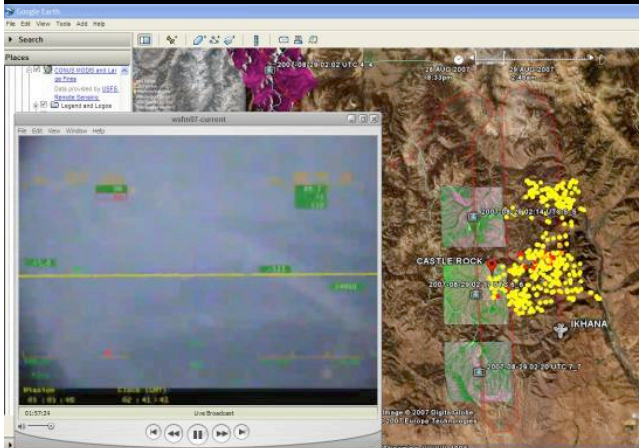
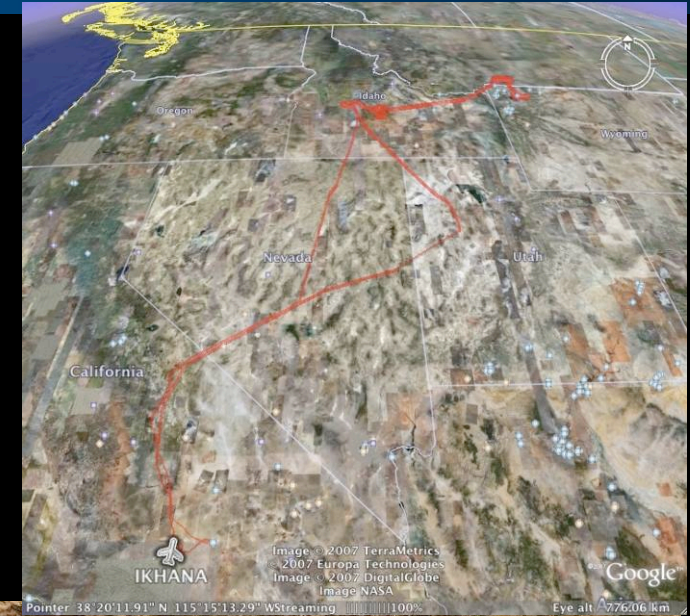



WSFM #3 - September 7-8, 2007

IKHANA

- Collected and transmitted real-time fire data on eleven fires spread through CA (Butler, North, Fairmont, Grouse, Lick, Bald, Moonlight, Zaca), OR (GW & Big Basin Fires), and WA (Domke Lake and South Omak Fires),
- Made repeat passes over most, (total of 18 fire visits) spending significant time over high priority fires (Lick, Moonlight, and GW)

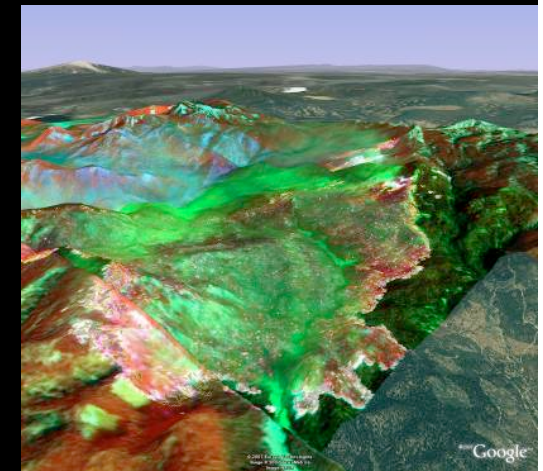
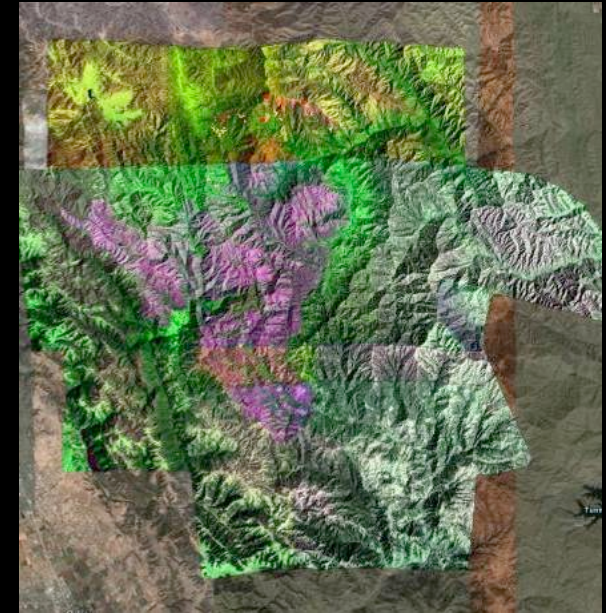
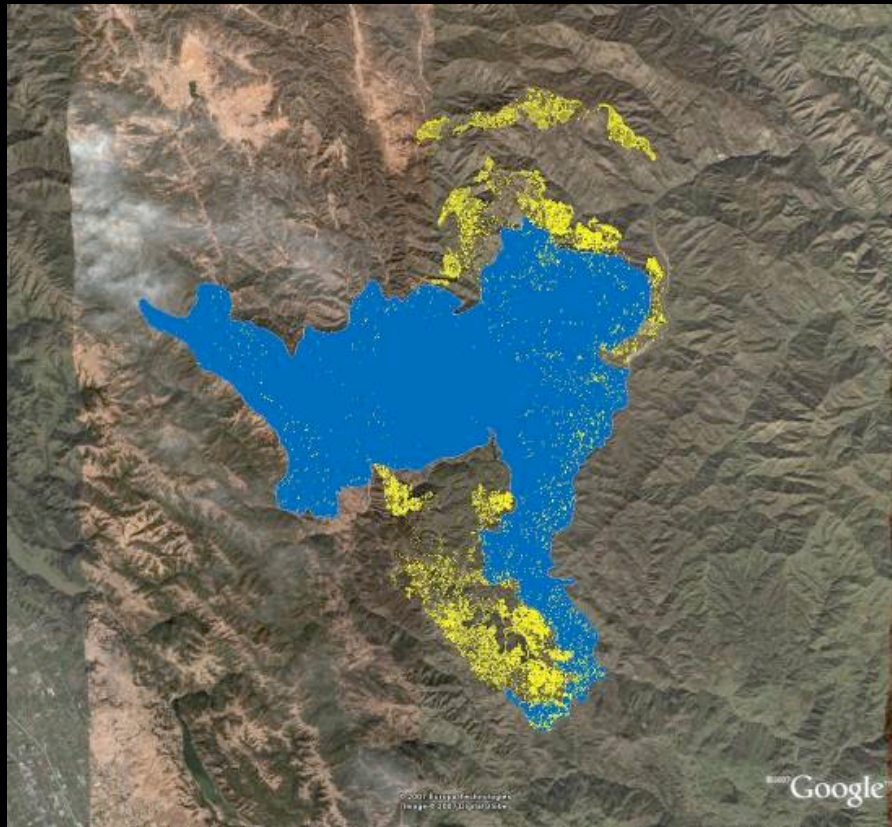



California Emergency Wildfire Response

IKHANA

- Oct 20-21: High winds (>50 MPH) drive wildfires in 4 southern California counties
- Oct 22nd: Ikhana team began preparation for a possible fire mission
- Two impediments to launching a mission
 - Failed hard drive in the wildfire sensor
 - Ikhana wings being modified for fiber-optic wing sensor demonstration
 - Tiger team assembled to assess airworthiness

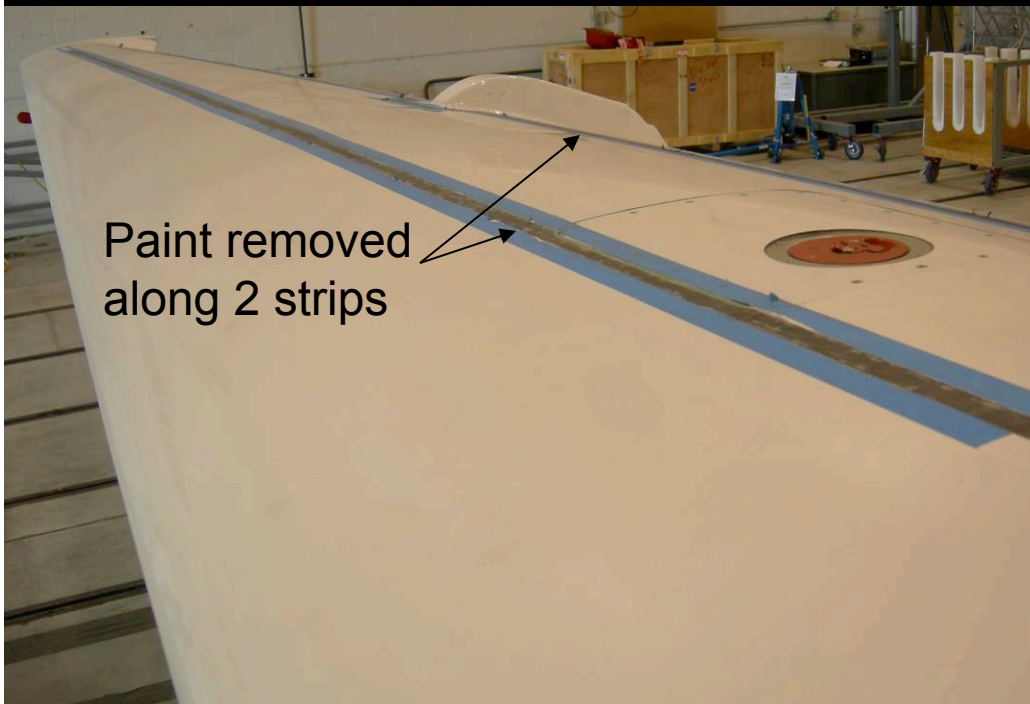



California Emergency Wildfire Response

IKHANA

Oct 22nd - Monday

- Ikhana Project team contacted by California Office of Emergency Services requesting imagery of Southern California wildfires
 - Kim Zagaris, Chief Fire and Rescue Branch
 - 500,000 people evacuated
 - More than 11 fires burning
- Planning telecons held with NASA teams and USFS
- FAA notified
- Range safety office began reviewing population centers around fire areas
- NASA Ames and USFS teams deploy to Southern California
- Wing repair completed

Oct 23rd - Tuesday

- Sensor hard drive repaired and verified
- FAA extended 75 nm COA limit to the south
 - Could not extend COA to within 10 nm of Mexican border (Harris fire)
- Mission plan submitted to FAA
- Tech Brief of mission plan delivered to NASA Dryden Management

Oct 24th - Wednesday

- Launched 1st emergency response mission @ 9am



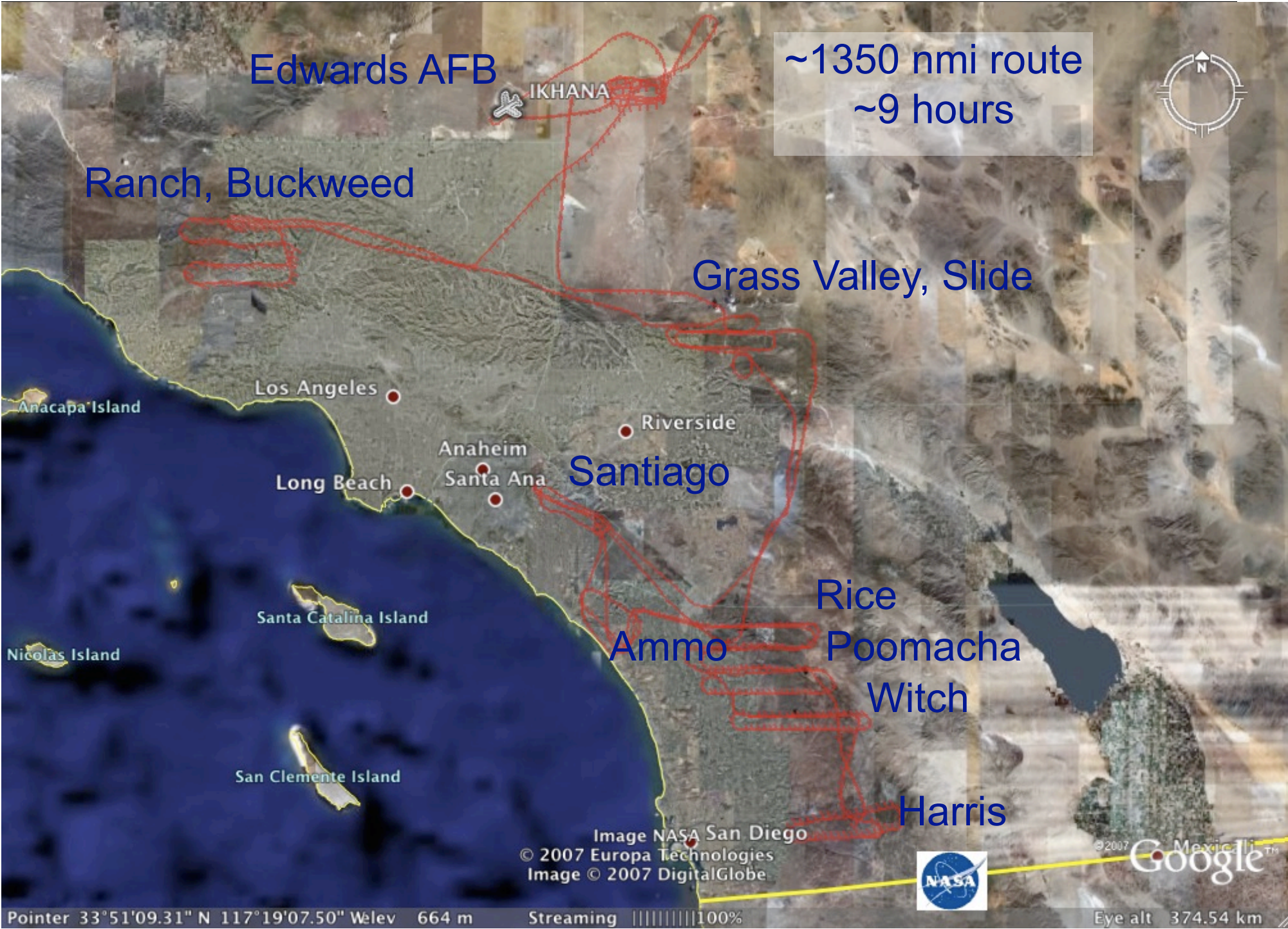

Edwards AFB

IKHANA

~1350 nmi route
~9 hours

Ranch, Buckweed

Grass Valley, Slide

Los Angeles

Riverside

Anaheim

Santiago

Long Beach

Santa Ana

Rice

Ammo

Poomacha

Witch

Harris

Image NASA San Diego
© 2007 Europa Technologies
Image © 2007 DigitalGlobe



©2007 Google



WSFM #5 - Ammo Fire, Oct 24th

IKHANA

Hot spots in yellow

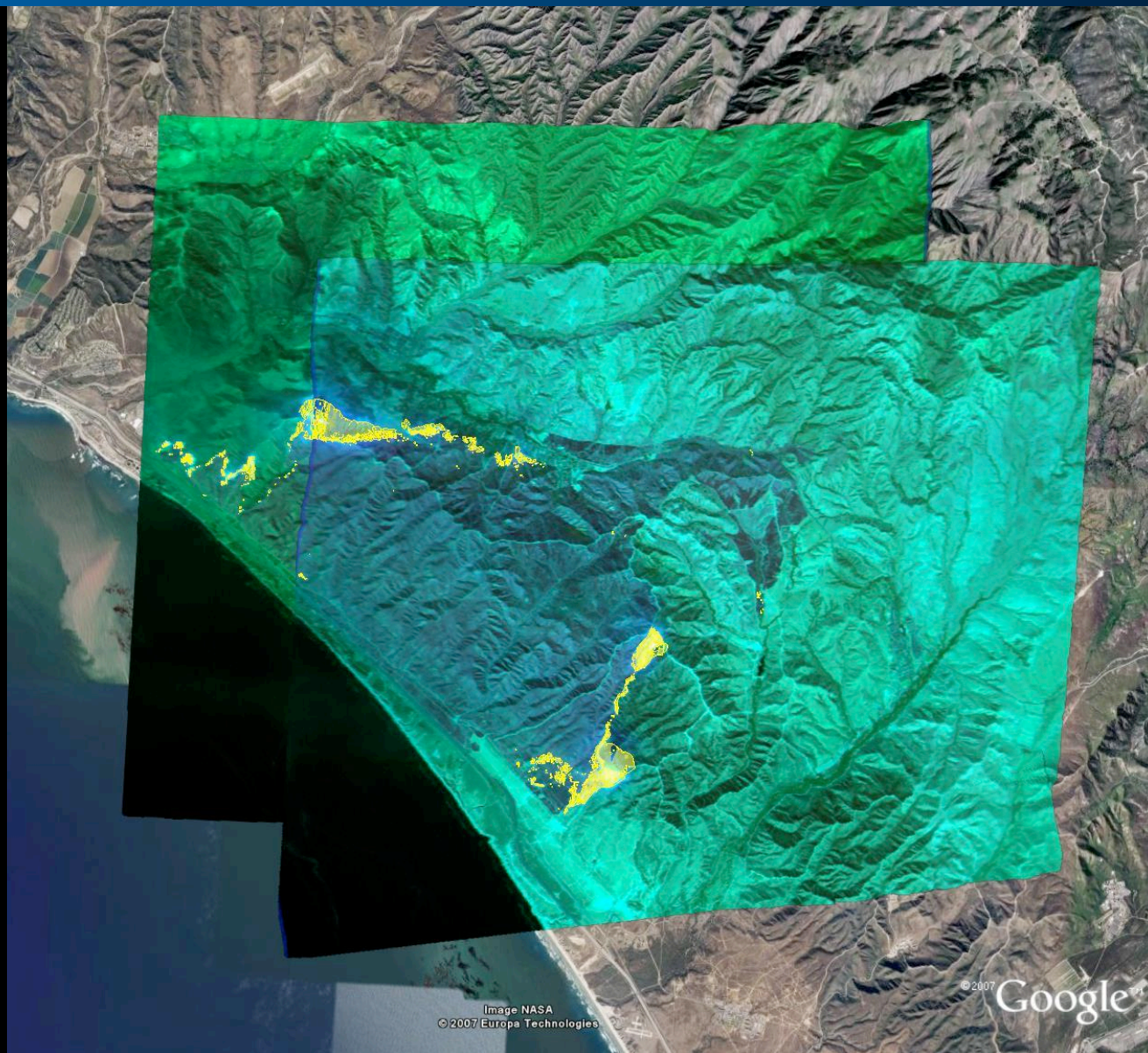



WSFM #6 - Oct. 25th

IKHANA

Hot spots in yellow

**Poomacha / Rice Fires –
3D with Hot Detects**

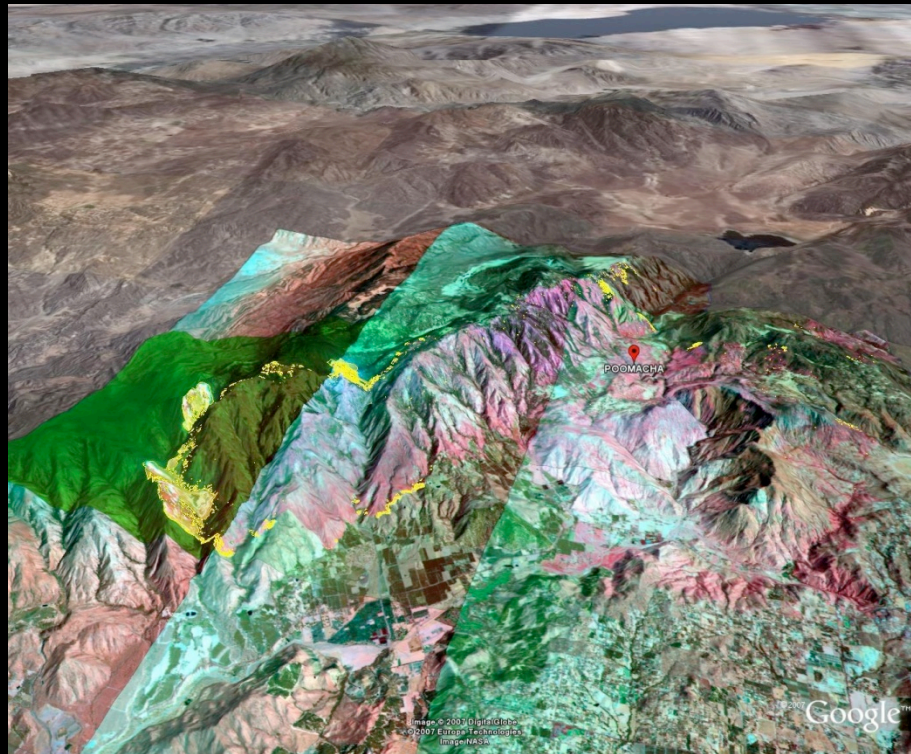

**Grass Valley / Slide Fires -
3D with Hot Detects**

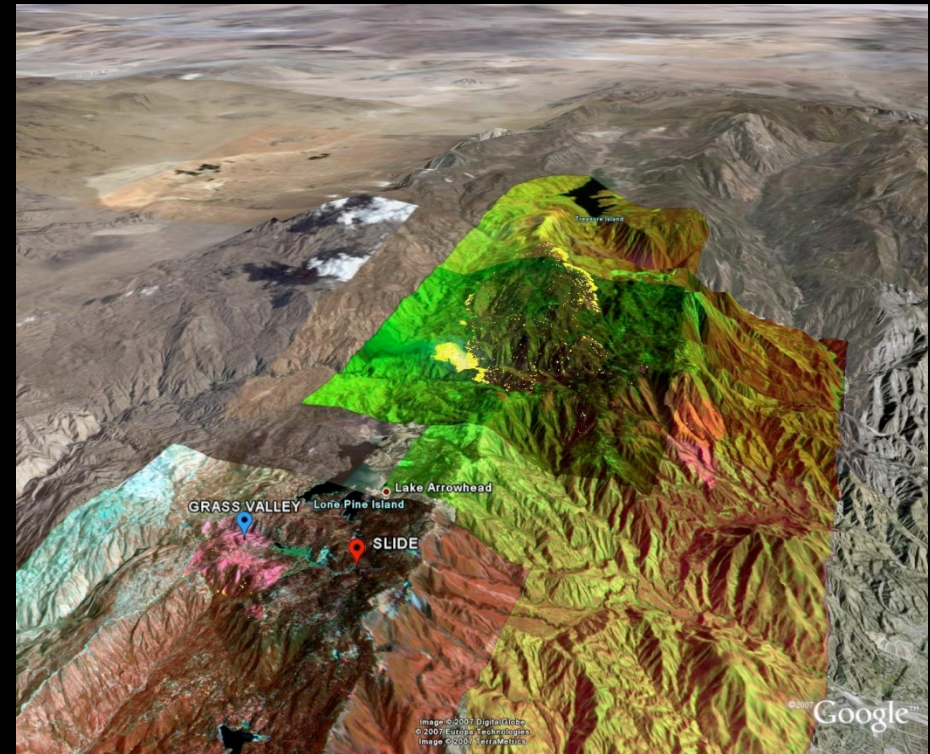



WSFM #7 - Oct. 26th

IKHANA

SANTIAGO FIRE

Hot spots in yellow

**Santiago Fire –
3D with Hot Detects**



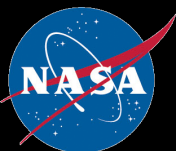

WSFM #8 - Ammo Burn Area, Oct. 28th

IKHANA

AMMO FIRE

**Sensor optimized
for Burn Area
Emergency
Response (BAER)
imagery**

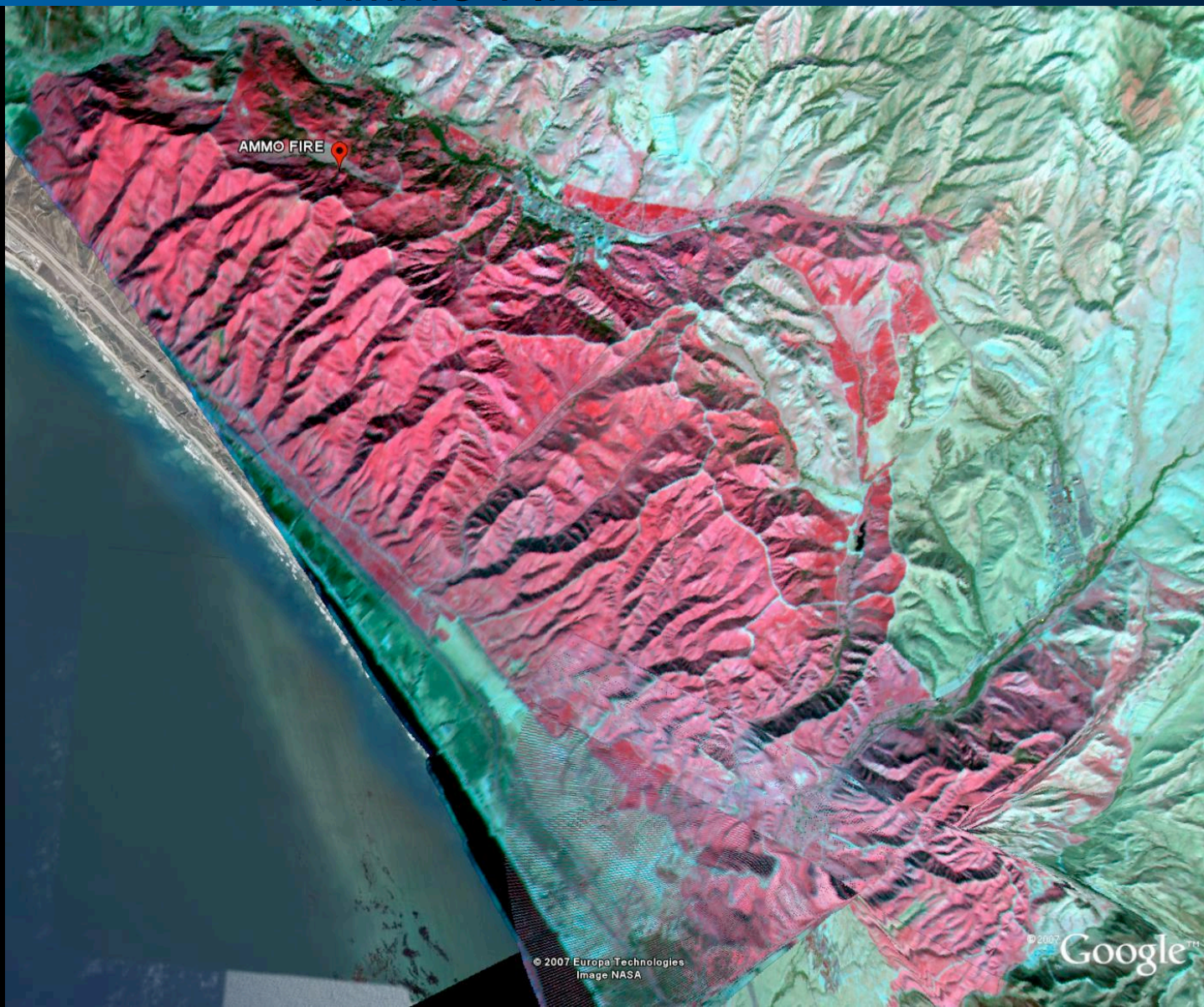



WSFM #8 - Santiago Fire, Oct. 28th

IKHANA

SANTIAGO FIRE

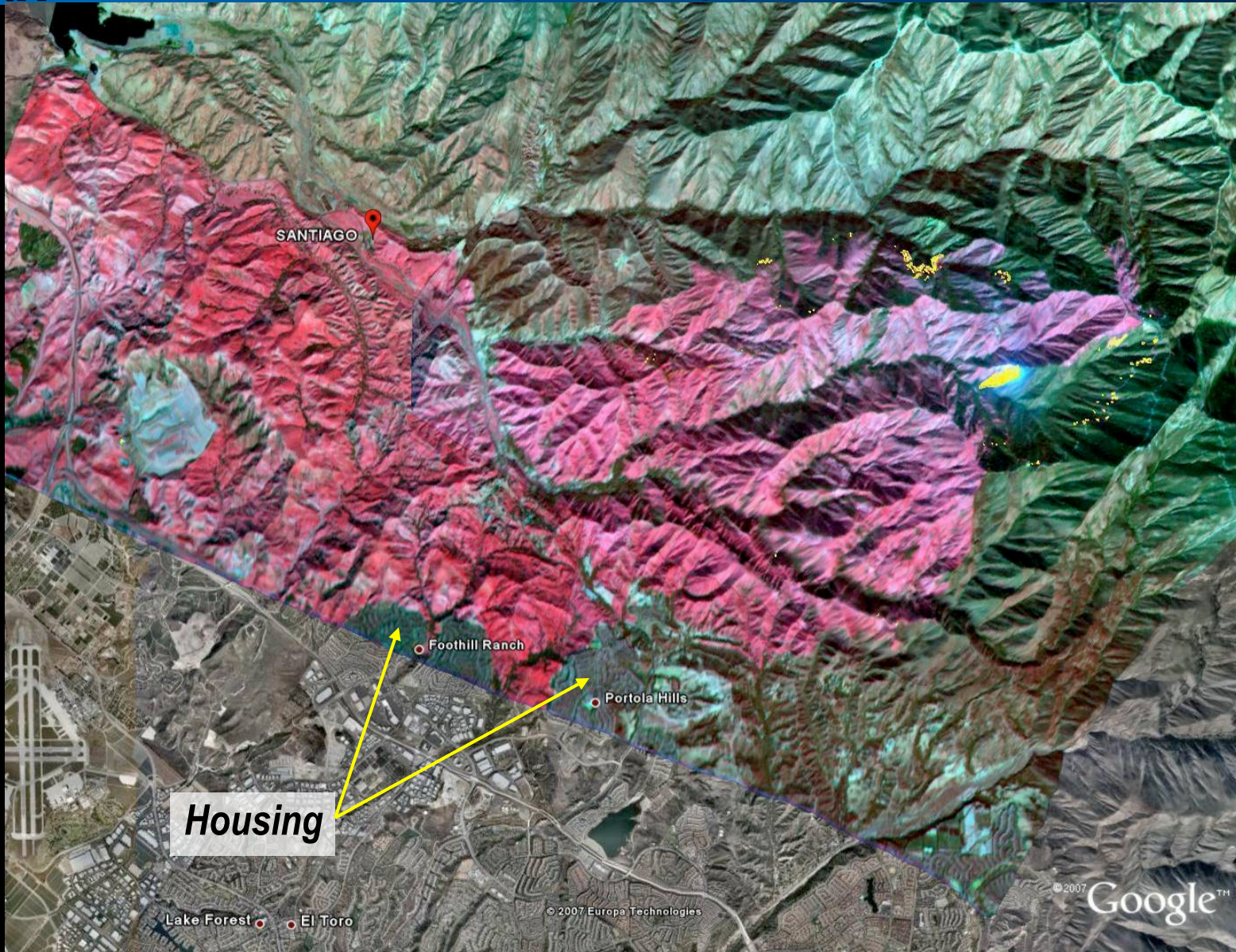



WSFM #4-#8 Southern California Results

IKHANA

- Four 9-hr missions flown
 - 5 day period covering Wednesday, Thursday, Friday, Sunday
 - Post flight debrief with DFRC team
 - Post flight/preflight brief with FAA HQ and LA Center
- Air Traffic Control gave excellent support
 - Mission plans flown in reverse
 - Real time requests for revisits of active fires
 - Added new fire during mission
 - Moved fire loiter points as fires moved
- Thermal infrared imagery delivered in near real-time (5 to 15 minutes) to:
 - Emergency ops: FEMA, NIFC, NorthCom, California EOC
 - Individual Fire Incident Commands
- Ventura County Fire Chief reported:
 - “Intel” was used tactically to fight the fires
 - “Intel” was used strategically to prioritize fires and allocate resources between fires
 - “Intel” was used to allow some fires to burn into each other



2007 WSFM Challenges

IKHANA

- GPS Testing – 250+ nm RADIUS
 - Nellis Range
 - China Lake
- C-band frequency access
 - Competing with Gray Butte Operations
- Emergency landing site permission
- Weather
 - Wind
 - Clouds
 - Icing
 - Thunderstorms
- Airfield use outside of normal operating hours
- Long missions

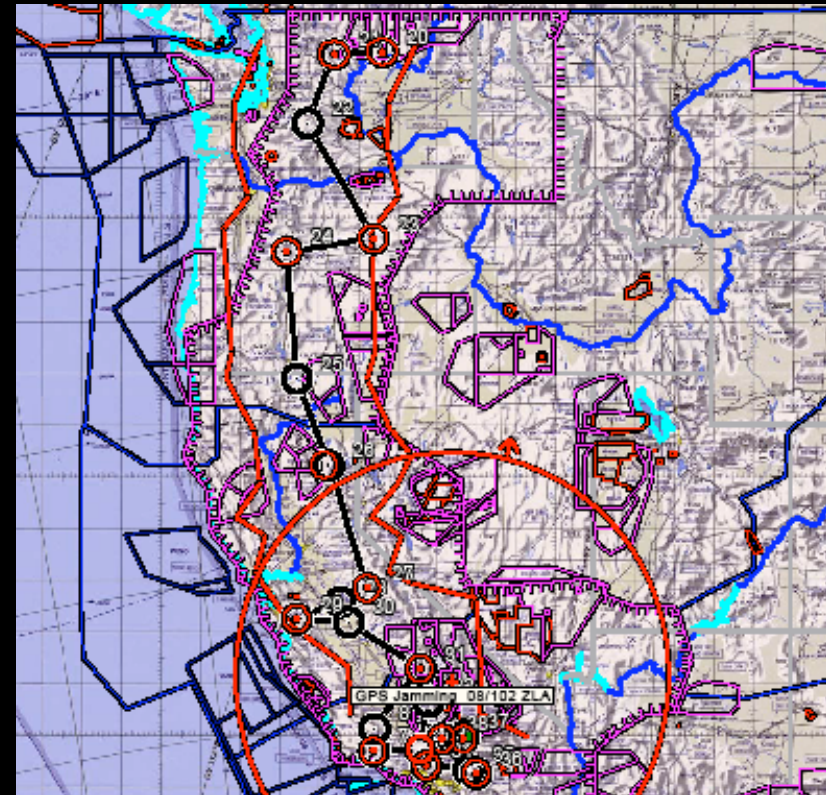



Credit where Credit is Due

IKHANA

- THE FAA HQ UAPO (UAS) Office
 - Not possible without GREAT cooperation and communication
- FAA ATC Centers and Controllers
 - Los Angeles, Oakland, Seattle, Salt Lake, Albuquerque, Denver
- USAF
 - Gray Butte for Command/Control frequency flexibility
 - Nellis Range for GPS Testing flexibility
- DFRC Range Safety Office (RSO) - Population Keep-out Zones
- Secondary Emergency Landing Site Selection Team
 - Project mgmt, RSO, Pilots, Operations
 - Identified, analyzed, categorized, prioritized, and cataloged over 280 sites
- General Atomics

NASA Global Hawk: A New Tool for Earth Science Research

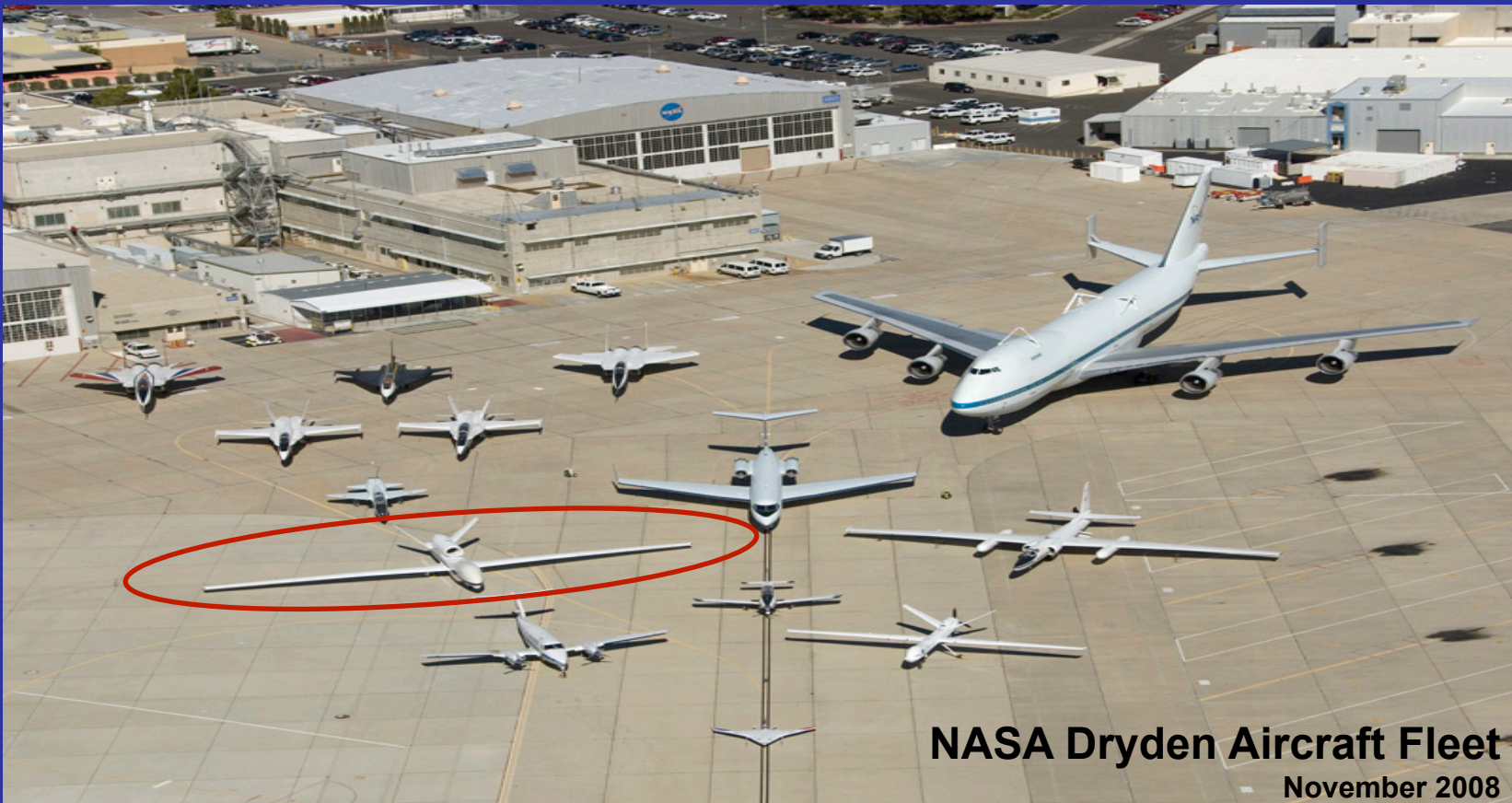

NASA Dryden Aircraft Fleet
November 2008





Global Hawk Block Approach

BLOCK 0 (ACTD)



- 7 Aircraft with ISS (EO/IR/SAR)
- First flight FY98, GWOT in FY02
- 2 Transferred to NASA for Environmental Research in FY07
- 1 USAF Test Bird at Edwards AFB



BLOCK 10



- 7 AF; 2 Navy aircraft
- Raytheon ISS (EO/IR/SAR Sensor)
- Operational in CENTCOM Jan 06
- Training & MCE at Beale AFB

BLOCK 20



- 6 USAF aircraft
- Raytheon Enhanced ISS (longer range)
- NG-ES LR-100 ELINT
- IOT&E and Fielding in 2009

BLOCK 30 (MULTI-SIGINT)



- 26 Vehicles – SIGINT Fielding in FY11
- Raytheon Enhanced ISS (longer range)
- NG-MS Adv Signals Intel Payload (ASIP)
- Operational 25+ Years; 40,000 Flight Hours

BLOCK 40



- 15 Planned, Air National Guard
- MP-RTIP AESA Radar (NG-IS with Raytheon and NG-ES as Subs)
- Ground/Maritime Radar Surveillance
- IOT&E and Fielding in FY10

NOTIONAL BLOCK X

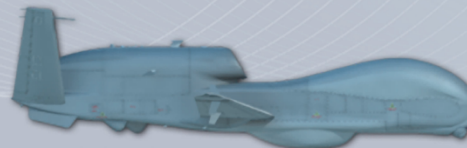

- BAMS (Broad Area Maritime Surveillance) USN Program
- Ballistic Missile Tracking, Abn IR System
- SPIRITT, LIDAR & FOPEN for USAF
- International – New Payloads
- NOAA – Environmental Surveillance

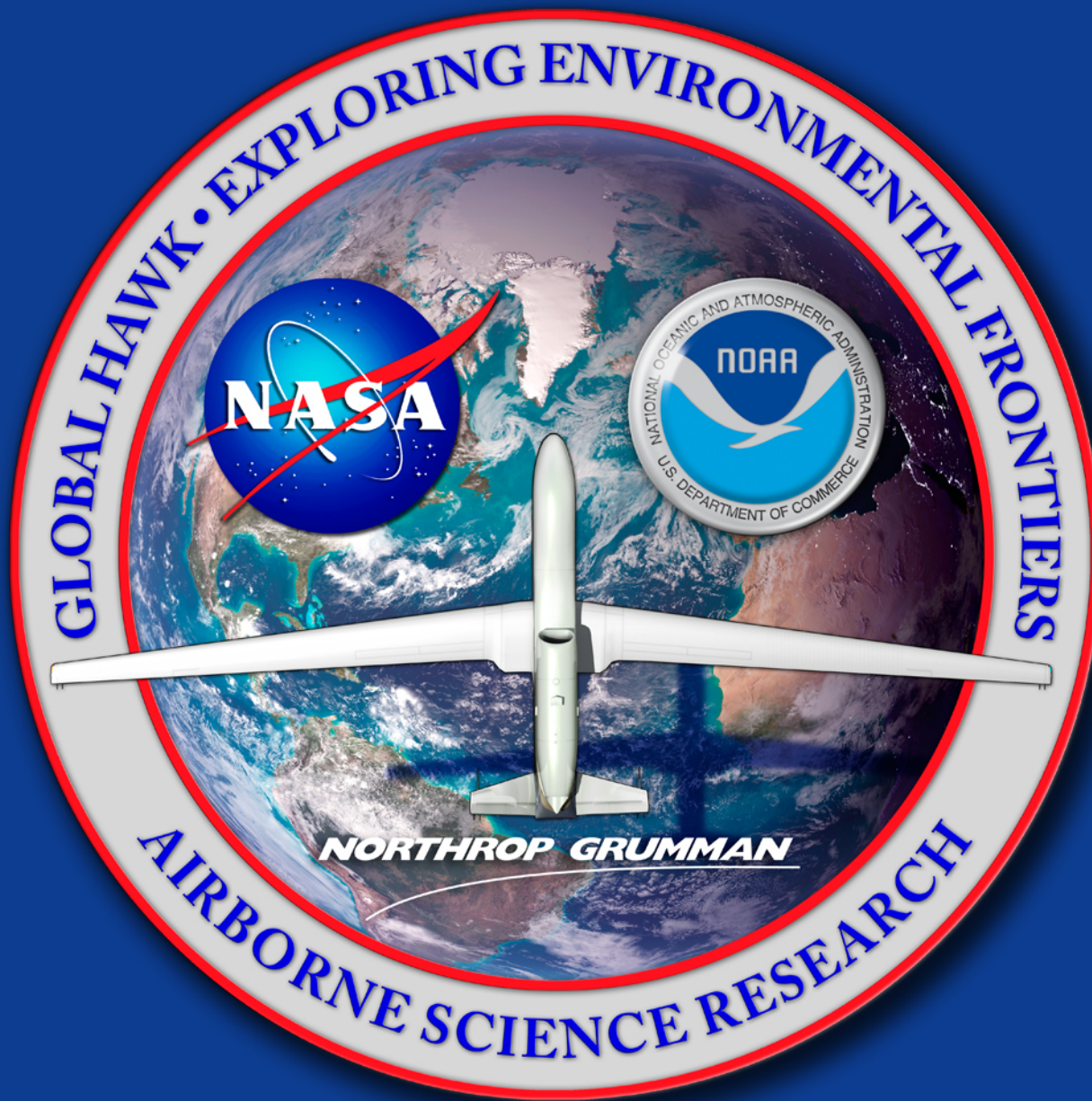

GLOBAL HAWK • EXPLORING ENVIRONMENTAL FRONTIERS

NORTHROP GRUMMAN

AIRBORNE SCIENCE RESEARCH



Global Hawk Specs

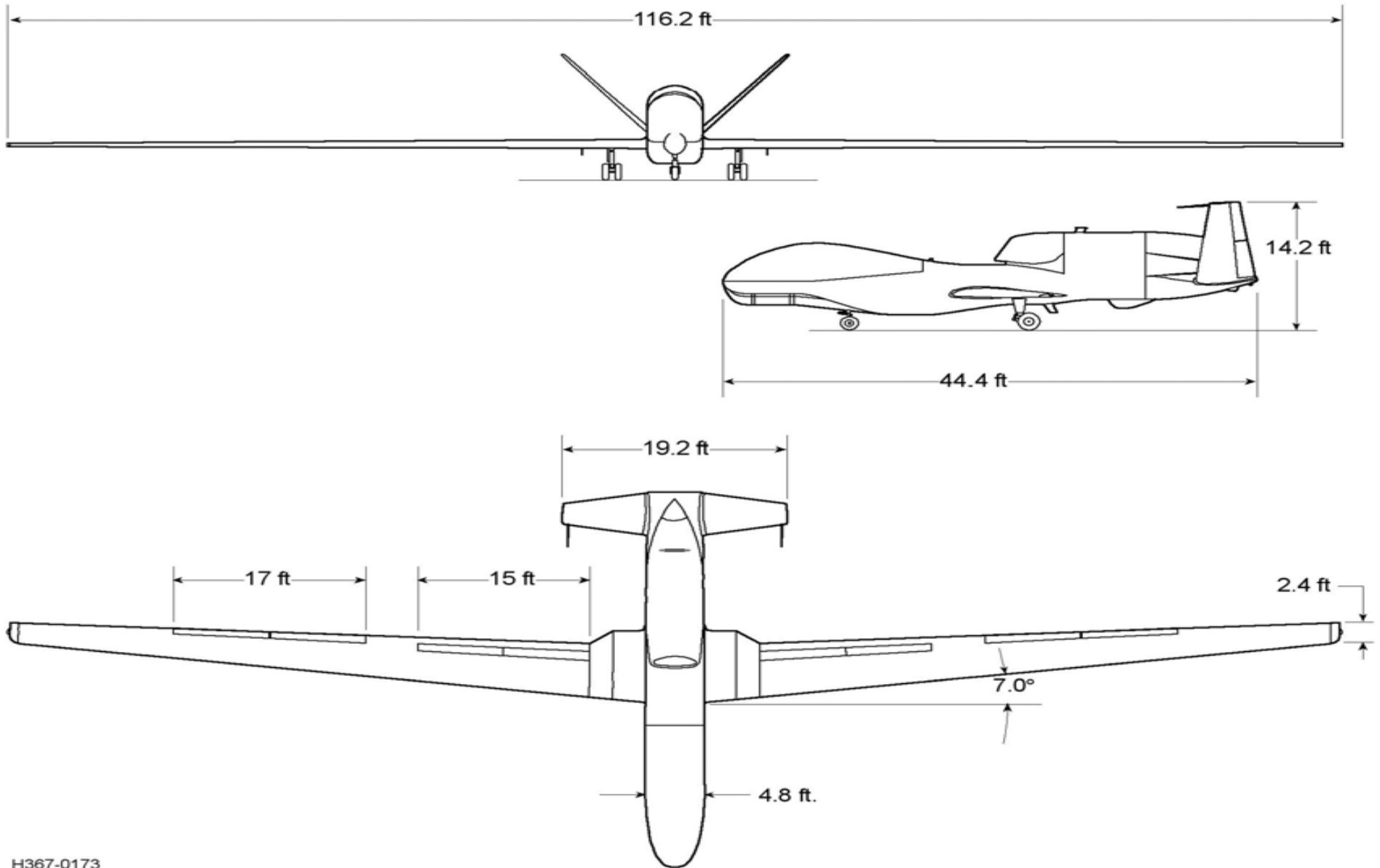

Global Hawk Specs

- Range >10,000 nmi
- Endurance >31.5 hours
- Maximum Altitude 65,000 feet
- Gross Weight 26,750 lbs
- Fuel Capacity 15,300 lbs
- True Airspeed 335 knots
- Payload Weight 1000-1500 lbs
- Payload Power 10 kVA
- Payload Volume >100 ft³
- Airfield requirement 8,000 x 150 feet
- Engine AE-3007H
- Fuel JP-8
- AV-1 <600 flight hours
- AV-6 <200 flight hours
- Autonomous all phases of flight



NORTHROP GRUMMAN

Global Hawk Operational Capability

Four Mission Regions, with Arcs of Constant On-Station Times

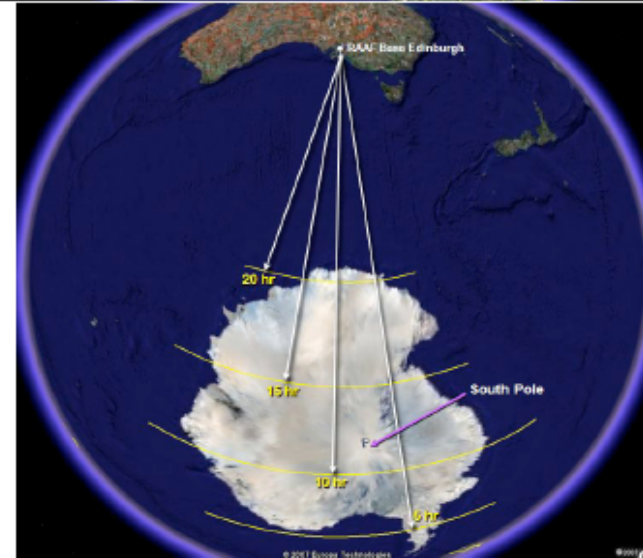
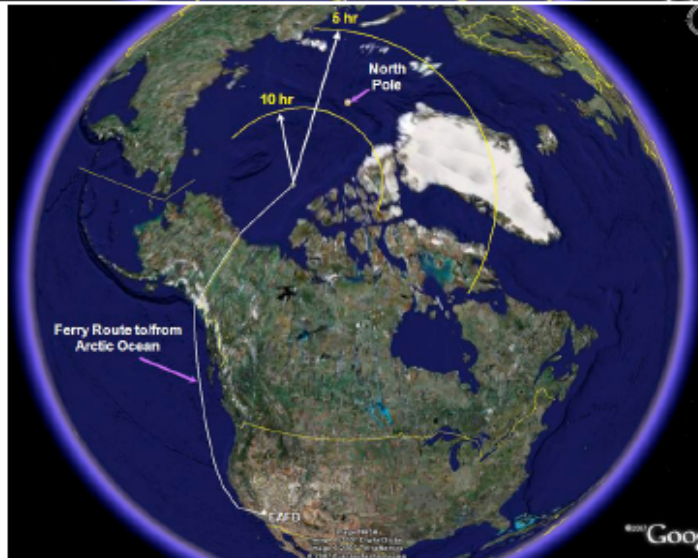
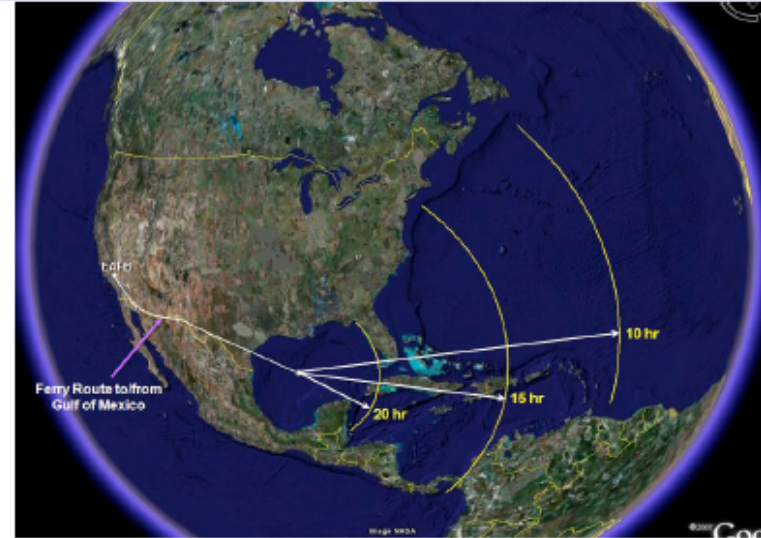
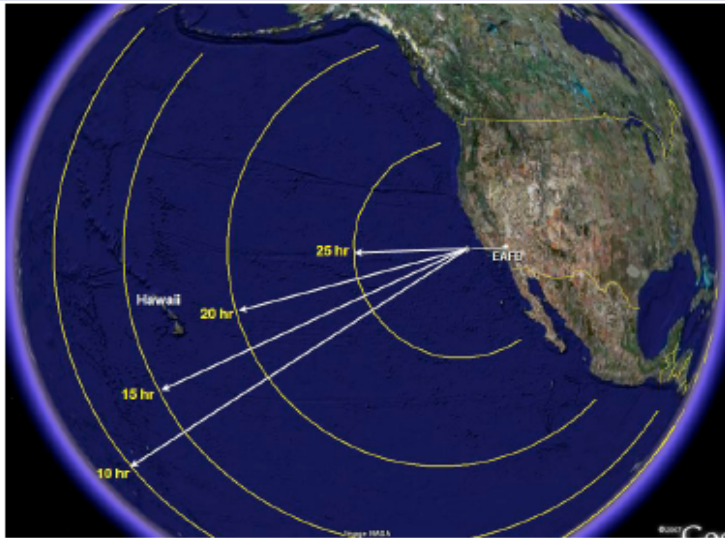



NASA Global Hawks





Global Hawk ship 006 NASA 872





Dryden Global Hawk



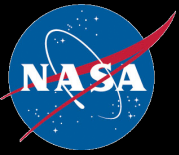

Dryden Global Hawk



















GHOC (Global Hawk Ops Center)



Global Hawk Operations Center (GHOC)

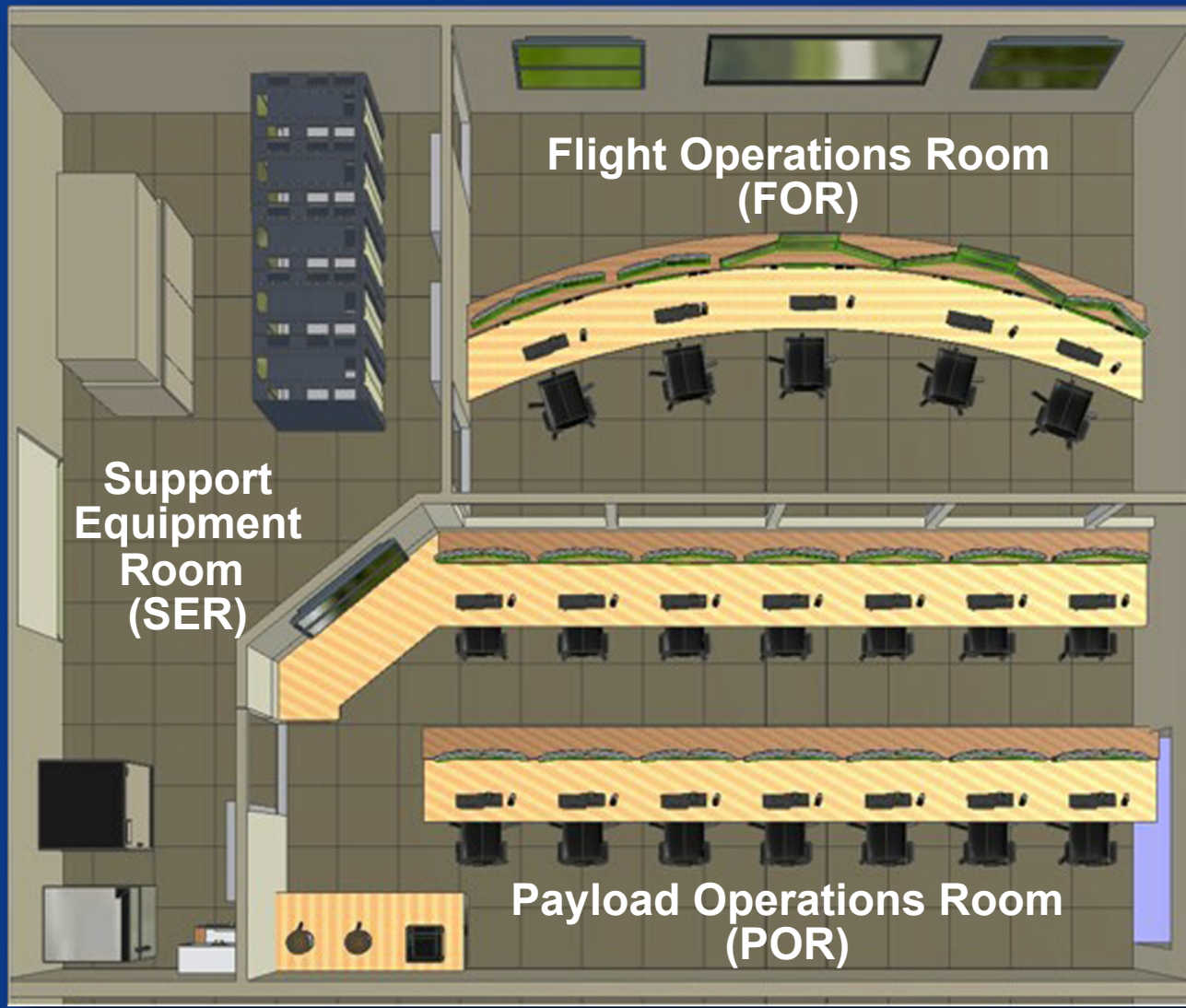



DFRC Global Hawk Operations Center (GHOC)





GHOC





Roll out ceremony



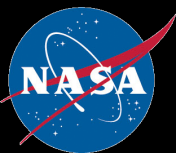

15 Jan 09: NASA/NGC Roll-out Ceremony

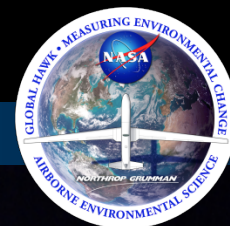



Global Hawk Pacific

GloPac 2009

Global Hawk Pacific Science Campaign (GloPac '09)



- Flights planned for Sept-Oct 2009
- Flights will be conducted over the Pacific Ocean, and possibly over parts of the Arctic
- 11 Instruments, sponsored by NASA and NOAA

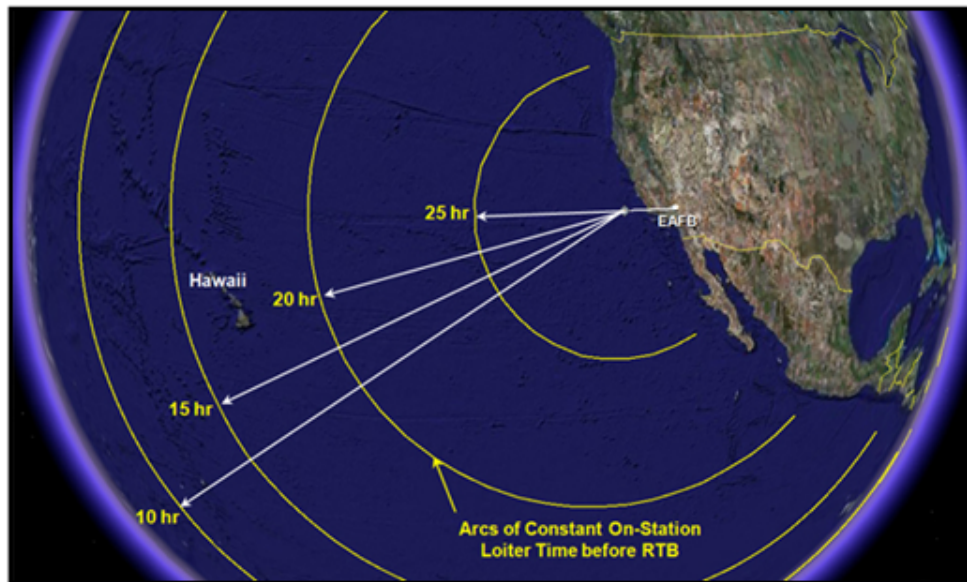

GloPac '09 Payloads

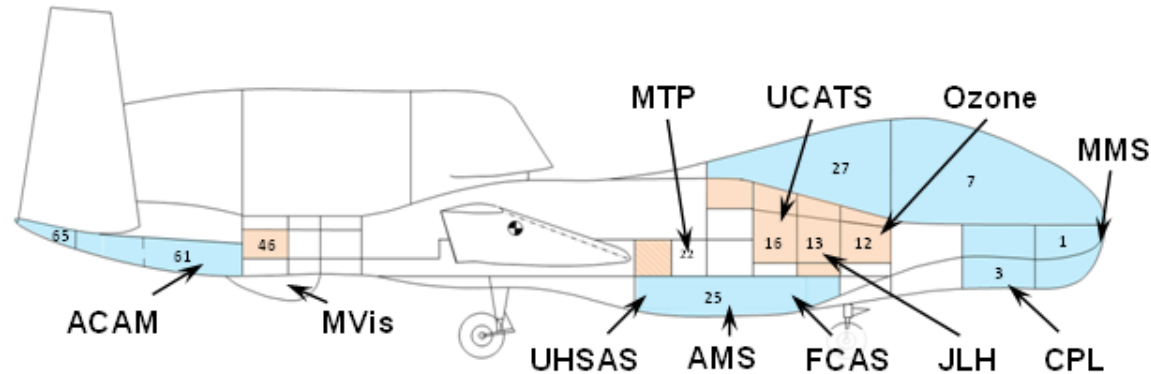

- ACAM** - Cross-track scanning spectrographs of NO_2 , O_3 , & aerosols.
- AMS** - Multi-spectral scanner for upper tropospheric water vapor meas.
- CPL** - Backscatter LIDAR for hi-res profiling of clouds & aerosols.
- FCAS** - Aerosol size and concentration measurements.
- MMS** - Science quality aircraft state variable measurements.
- MPT** - Passive microwave radiometer meas. of O_2 thermal emissions.
- MVis** - Time-lapse nadir color digital imagery w/ georeferencing.
- Ozone** - Dual-beam UV photometer for accurate O_3 measurements.
- UCATS** - Dual gas chromatographs for N_2O , SF_6 , H_2 , CO , & CH_4 meas.
- UHSAS** - Ultra-high sensitivity aerosol spectrometer.
- ULH** - In-situ hi-accuracy atmospheric water vapor measurements.

GloPac '09 Mission Planning

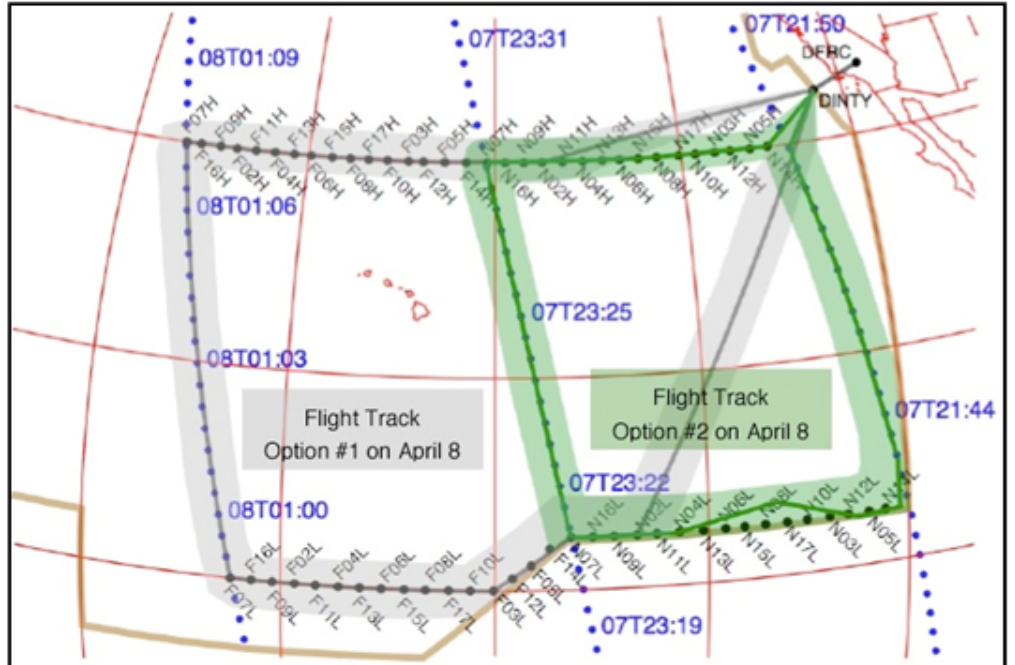
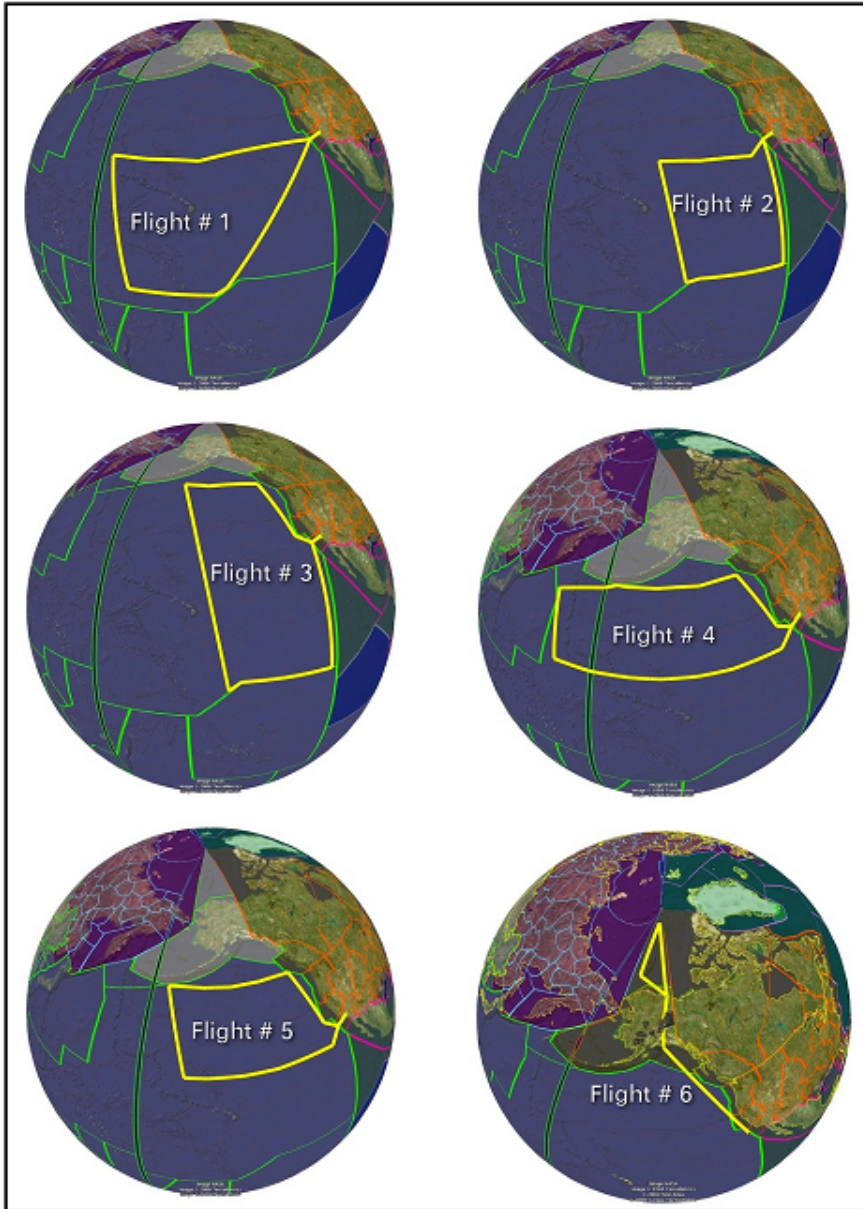

Cloud Physics Lidar (CPL)

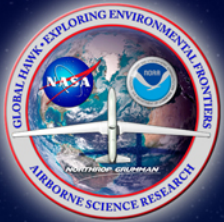

Matthew McGill, Goddard Space Flight Center

Stan Scott, Goddard Space Flight Center

Shane Wake, Goddard Space Flight Center

Marcos Sirota, Sigma Space Corporation

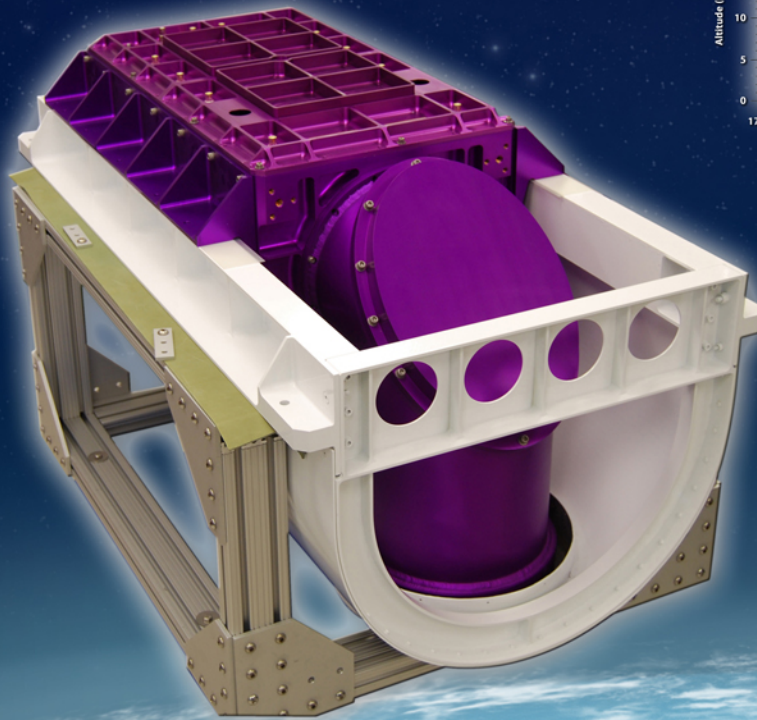

CPL 532 nm Attenuated Backscatter Profiles

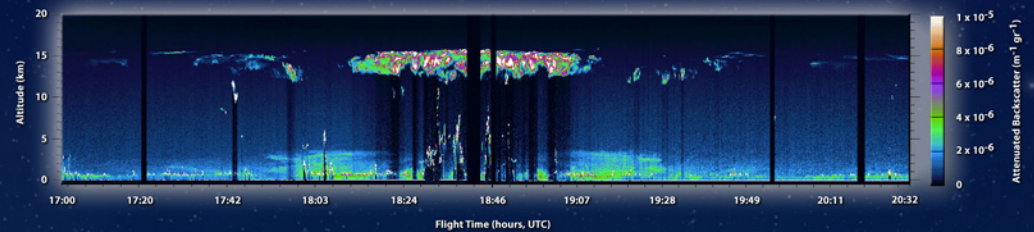

Example of CPL data showing 532 nm backscatter profiles. The image is representative of airborne lidar data, showing cloud height and internal structure (including cirrus, subvisible cirrus, low- and mid-level clouds, and multiple cloud layers) and boundary layer aerosol. In addition, a period of elevated aerosol, known to be Saharan dust, is evident in the middle of the time period.

CPL Optical Bench

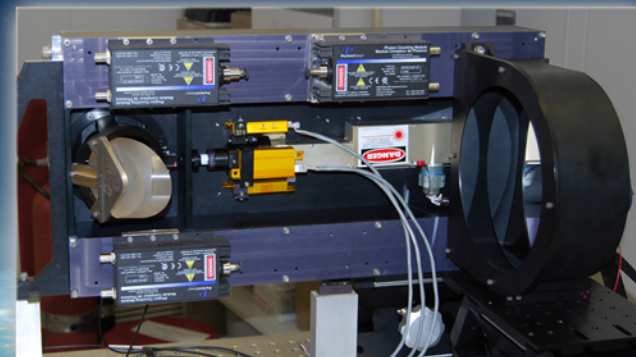

Ozone Photometer

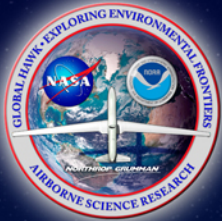

Ru-Shan Gao, NOAA Earth System Research Laboratory
Laurel Watts, NOAA Earth System Research Laboratory and CU CIRES
Steven Ciciora, NOAA Earth System Research Laboratory
David W. Fahey, NOAA Earth System Research Laboratory



Ozone Photometer Without Cover

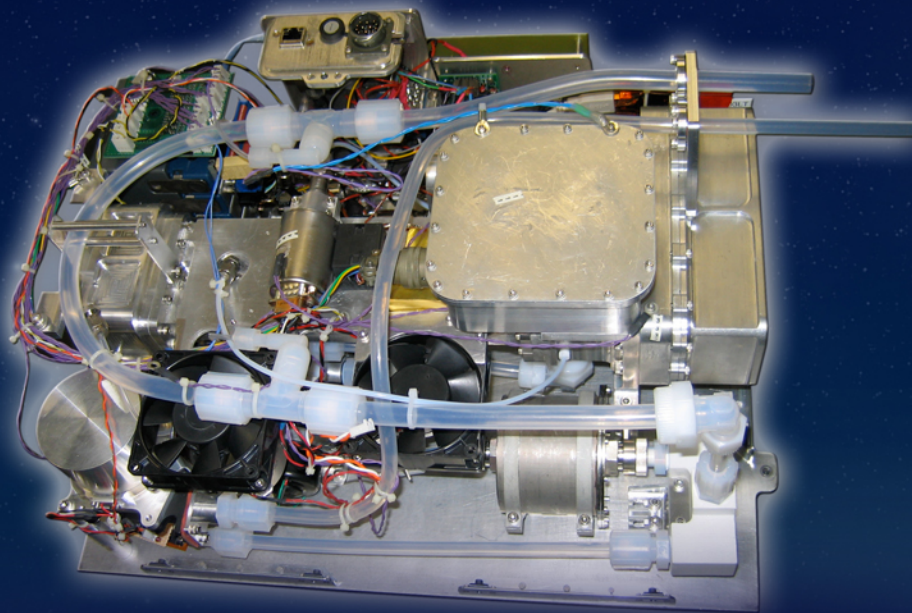

Ozone Photometer in Flight Configuration

Ozone Optics Schematic

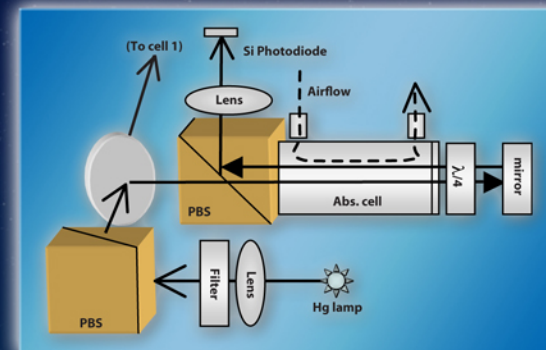

Schematic Diagram of the UAS Ozone Optics. A second cell, not shown, also includes a polarizing beamsplitter (PBS)/absorption cell/quarter waveplate ($\lambda/4$)/mirror/ $\lambda/4$ /PBS/lens optical path.

Specifications

Weight	37 lbs
Dimensions	19" x 13.5" x 8.5"
Data Rate	2 Hz
Accuracy	5% + Precision
Precision	$2 \times 10^{10} \text{ O}_3 \text{ cm}^{-3}$
Power Requirements (Avg)	28 V, 4.3 A (120 W)
Power Requirements (Max)	28 V, 5 A (140 W)
Operating Temperature	40° C maximum
Moving Parts	Valves
Consumables	None

UAS Laser Hygrometer (ULH)

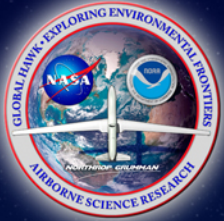

Robert L. Herman, Jet Propulsion Laboratory
Robert F. Troy, Jet Propulsion Laboratory
Anthony J. Scodary, Jet Propulsion Laboratory

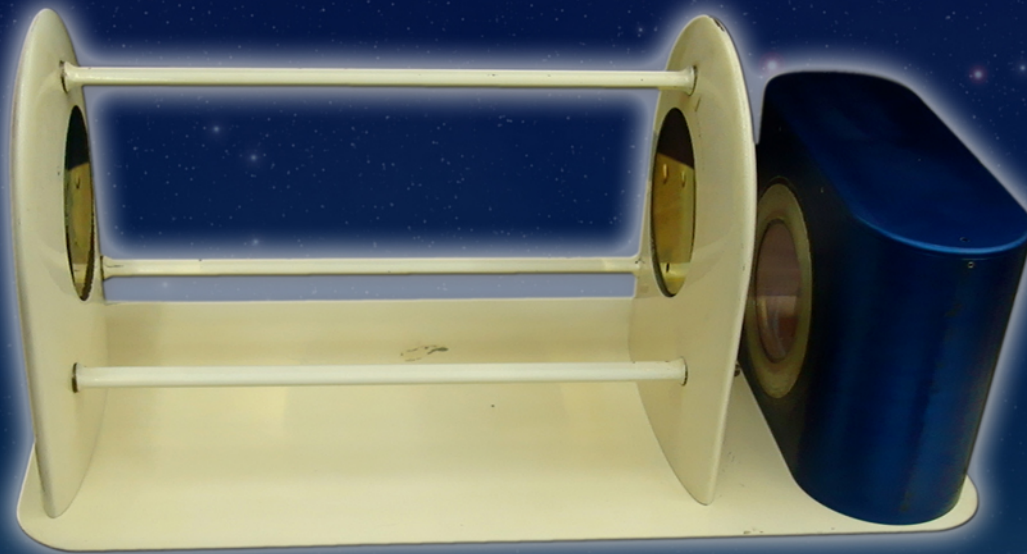

Microwave Temperature Profiler (MTP)

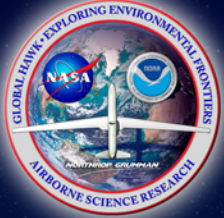

MJ Mahoney, Jet Propulsion Laboratory, California Institute of Technology
Richard Denning, Jet Propulsion Laboratory, California Institute of Technology



EU Russian Geophysica
EURPLEX - Kiruna, Sweden (2003)

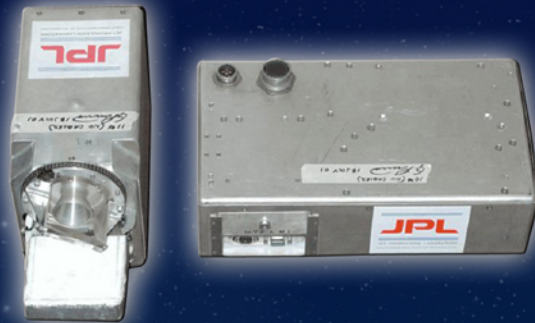

The MTP currently flies on the five research aircraft shown. The ER-2 MTP Server Unit (left) and the Data Unit (right) will be integrated into the Global Hawk for GloPac.



NASA DC-8
PAVE - Portsmouth, New Hampshire (2005)



NASA ER-2
TCSP - San Jose, Costa Rica (2005)



NASA WB-57F
CRAVE - San Jose, Costa Rica (2006)



NSF/NCAR Gulfstream V
START-08 - April - June (2008)

UAS Chromatograph for Atmospheric Trace Species (UCATS)

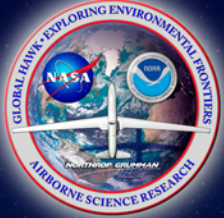

James W. Elkins, NOAA Earth Systems Research Laboratory
Fred L. Moore, NOAA Earth Systems Research Laboratory and CIRES
Samuel J. Oltmans, NOAA Earth Systems Research Laboratory

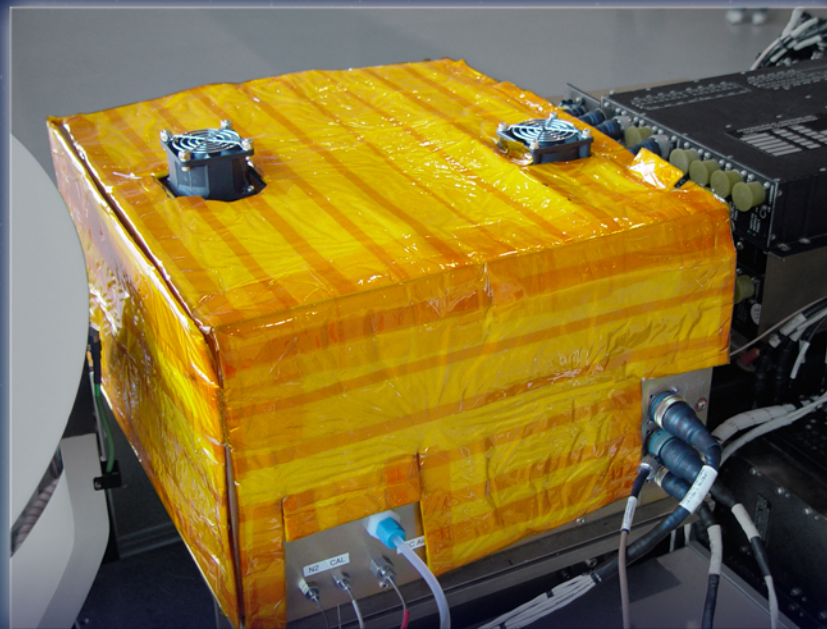

Meteorological Measurement Systems (MMS)

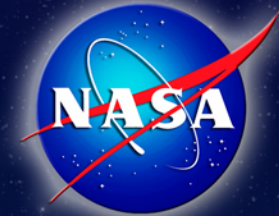
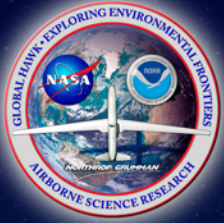

T. Paul Bui, Ames Research Center

Stuart W. Bowen, Bay Area Environment Research Institute

Cecilia Chang, Bay Area Environment Research Institute

Jonathan Dean-Day, Bay Area Environment Research Institute

Leonhard Pfister, Ames Research Center



ER-2 and WB57 Coordinated Flight Temperature Comparison

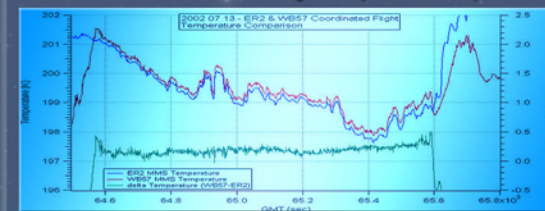

ER-2 and WB57 Coordinated Flight Vertical Wind Speed Comparison

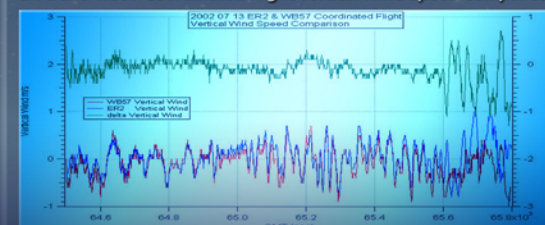

Airborne Compact Atmospheric Mapper (ACAM)

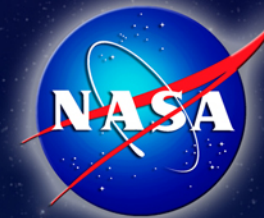

Dr. Scott Janz, Goddard Space Flight Center
Dr. Paul Newman, Goddard Space Flight Center

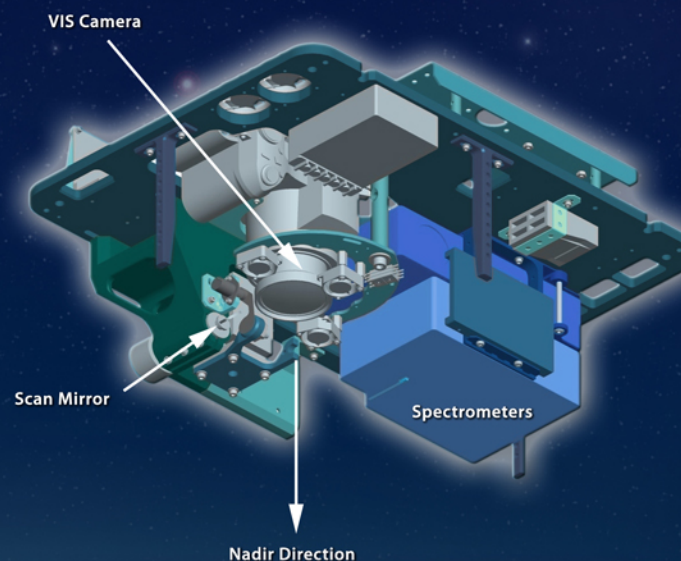
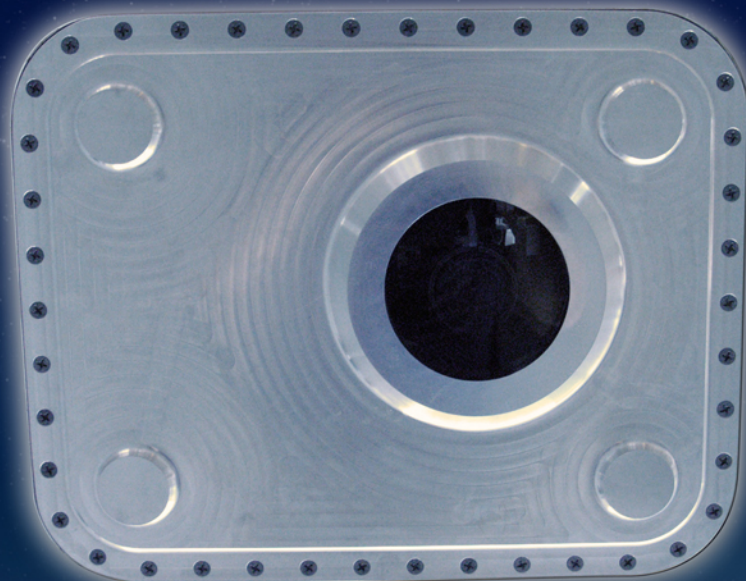

Description



UAVSAR

Scott Hensley, UAVSAR Chief Scientist, Jet Propulsion Laboratory

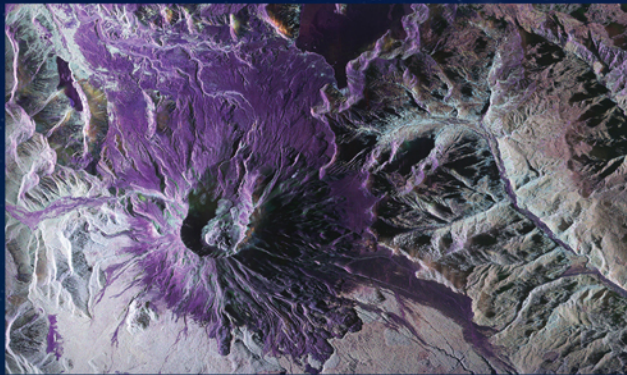
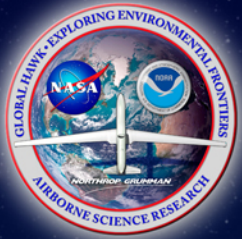

This false color, polarimetric image of Mount Saint Helens was collected by UAVSAR in 2008 from an altitude of 41,000 feet on board the Gulfstream III aircraft.





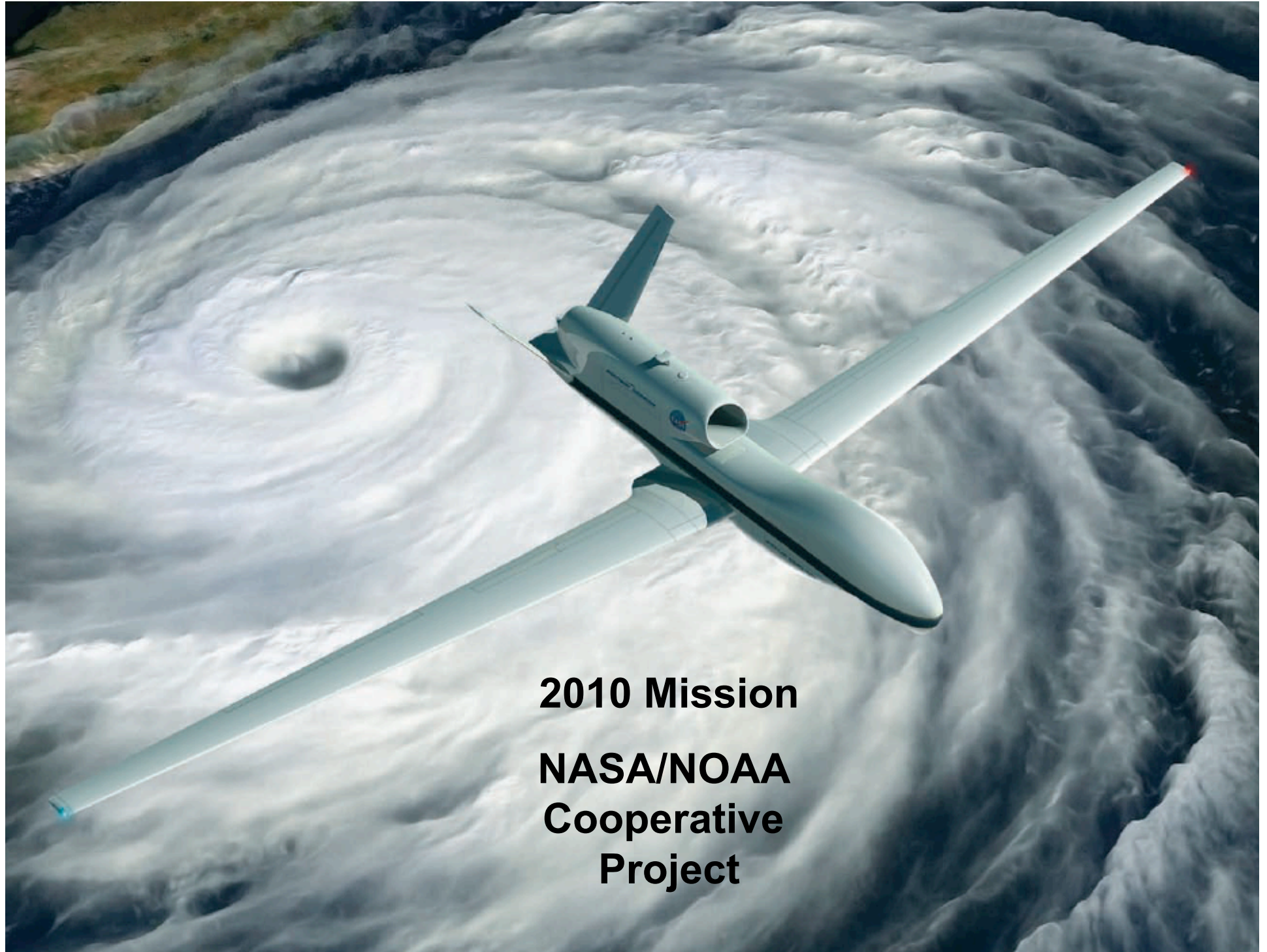

**2010 Mission
NASA/NOAA
Cooperative
Project**

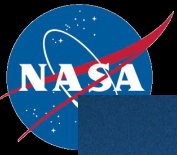

IK



