

terrain. Data are communicated between modules via fast serial links in the module interfaces.

An Axel n amounts to a train carrying $n/2 - 1$ instrument modules. The instrument modules contain additional computational units that, in addition to processing of instrument readings, contribute to coordination of motion. In other words, the “intelligence” of an Axel n , and thus the sophistication of the maneuvers that it can perform, increase with n . The symmetrical design of the modules enables them to operate in any stable orientation, including upsidedown; this feature contributes to robustness of operation in rough terrain. A fully developed Axel n would be able to diagnose itself to detect non-functional modules.

Going beyond the description in the cited prior article, the following additional major items of the hardware can now be reported.

Also contained within the axle of an Axel2 is a stereoscopic pair of electronic cameras to be used for navigation across terrain, for scientific observations, and for guidance in docking maneuvers.

Each module interface is an electro-mechanical module located at the mid-length of the axle of an Axel2. The module interface carries female parts of mating mechanisms, while instrument modules carry the male parts. The mating mechanisms include conical mating surfaces that correct for small initial misalignments to facilitate

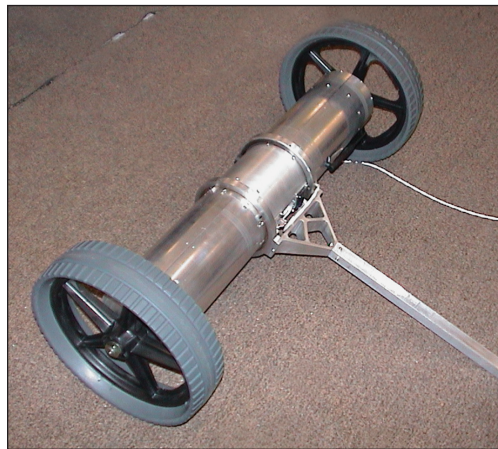

Figure 1. This Two-Wheeled Vehicle is a prototype of an Axel2.

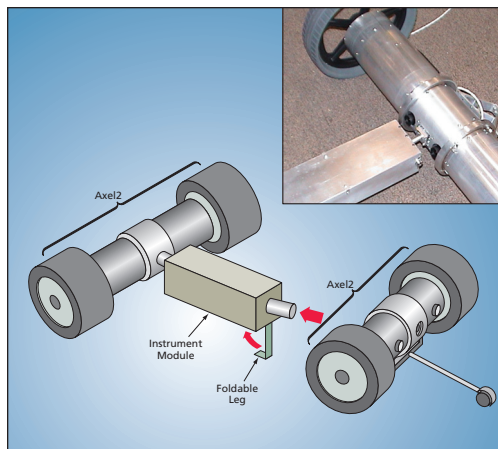

Figure 2. The Prototype Axel2 and a Prototype Instrument Module are depicted here during a docking maneuver that ends in coupling at the module interface.

autonomous coupling of an Axel2 with an instrument module.

Information on the Axel n software has become available since the prior article was published. To enable self-diagnosis and automatic reconfiguration of modular hardware, the architecture of the Axel n software provides for autonomous adaptation of the software to the hardware reconfiguration. More specifically, an Axel n uses software that can determine when physical reconfiguration is necessary (e.g., in response to task requirements or hardware failures), controls the hardware reconfiguration, and reconfigures itself to conform to the changed hardware configuration.

The capability for autonomous reconfiguration of the hardware depends heavily on the supporting software. One of the goals of the development of the Axel n system is to simplify and generalize through modularity. The reconfigurable software architecture mirrors the modularity of the hardware by providing that, as hardware modules are connected or disconnected, associated software modules are also put into or taken out of operation.

This work was done by Ayanna Howard, Issa Nesnas, Barry Werger, Daniel Helmnick of Caltech; Murray Clark and Raymond Christian of Arkansas Tech; and Raymond Cipra of Purdue University for NASA's Jet Propulsion Laboratory. For more information, contact iaoffice@jpl.nasa.gov. NPO-30890

⚙️ Thermostatic Valves Containing Silicone-Oil Actuators

NASA's Jet Propulsion Laboratory, Pasadena, California

Flow-splitting and flow-mixing thermally actuated spool valves have been developed for controlling flows of a heat-transfer fluid in a temperature-regulation system aboard the Mars Science Laboratory (MSL) rover. Valves like these could also be useful in terrestrial temperature-regulation systems, including automobile air-conditioning systems and general refrigeration systems. These valves are required to provide smoother actuation over a wider temperature range than the flow-splitting, thermally actuated spool valves used in the Mars Explorer Rover (MER). Also, whereas the MER valves are unstable (tending to oscillate) in certain transition temperature ranges, these valves are required not to oscillate.

The MER valves are actuated by thermal expansion of a wax against spring-loaded piston rods (as in common automotive thermostats). The MSL valves contain similar actuators that utilize thermal expansion of a silicone oil, because silicone-oil actuators were found to afford greater and more nearly linear displacements, needed for smoother actuation, over the required wider temperature range. The MSL valves also feature improved spool designs that reflect greater understanding of fluid dynamics, consideration of pressure drops in valves, and a requirement for balancing of pressures in different flow branches.

This work was done by Pradeep Bhandari, Gajanana C. Birur, David P. Bame, Paul B.

Karlmann, and Mauro Prina of Caltech and William Young and Richard Fisher of Pacific Design Technology for NASA's Jet Propulsion Laboratory.

In accordance with Public Law 96-517, the contractor has elected to retain title to this invention. Inquiries concerning rights for its commercial use should be addressed to:

*Innovative Technology Assets Management
JPL*

Mail Stop 202-233

4800 Oak Grove Drive

Pasadena, CA 91109-8099

E-mail: iaoffice@jpl.nasa.gov

Refer to NPO-45843, volume and number of this NASA Tech Briefs issue, and the page number.