



Radioisotope Electric Propulsion Centaur Orbiter Spacecraft Design Overview

*Steve Oleson, Melissa McGuire, Tim Sarver-Verhey, Jeff Juergens, and Tom Parkey
Glenn Research Center, Cleveland, Ohio*

*John Dankanich
Gray Research, Cleveland, Ohio*

*Doug Fiehler
ASRC Aerospace, Cleveland, Ohio*

*John Gyekenyesi and Joseph Hemminger
N&R Engineering, Cleveland, Ohio*

*Jim Gilland
Ohio Aerospace Institute, Brook Park, Ohio*

*Tony Colozza, Tom Packard, and Thahn Nguyen
Analex Corporation, Cleveland, Ohio*

*Paul Schmitz
Power Computing Solutions, Cleveland, Ohio*

*Paul Ostdiek, Rob Gold, Carey Lisse, and Karl Hibbits
Johns Hopkins University, Applied Physics Laboratory, Laurel, Maryland*

NASA STI Program . . . in Profile

Since its founding, NASA has been dedicated to the advancement of aeronautics and space science. The NASA Scientific and Technical Information (STI) program plays a key part in helping NASA maintain this important role.

The NASA STI Program operates under the auspices of the Agency Chief Information Officer. It collects, organizes, provides for archiving, and disseminates NASA's STI. The NASA STI program provides access to the NASA Aeronautics and Space Database and its public interface, the NASA Technical Reports Server, thus providing one of the largest collections of aeronautical and space science STI in the world. Results are published in both non-NASA channels and by NASA in the NASA STI Report Series, which includes the following report types:

- **TECHNICAL PUBLICATION.** Reports of completed research or a major significant phase of research that present the results of NASA programs and include extensive data or theoretical analysis. Includes compilations of significant scientific and technical data and information deemed to be of continuing reference value. NASA counterpart of peer-reviewed formal professional papers but has less stringent limitations on manuscript length and extent of graphic presentations.
- **TECHNICAL MEMORANDUM.** Scientific and technical findings that are preliminary or of specialized interest, e.g., quick release reports, working papers, and bibliographies that contain minimal annotation. Does not contain extensive analysis.
- **CONTRACTOR REPORT.** Scientific and technical findings by NASA-sponsored contractors and grantees.

- **CONFERENCE PUBLICATION.** Collected papers from scientific and technical conferences, symposia, seminars, or other meetings sponsored or cosponsored by NASA.
- **SPECIAL PUBLICATION.** Scientific, technical, or historical information from NASA programs, projects, and missions, often concerned with subjects having substantial public interest.
- **TECHNICAL TRANSLATION.** English-language translations of foreign scientific and technical material pertinent to NASA's mission.

Specialized services also include creating custom thesauri, building customized databases, organizing and publishing research results.

For more information about the NASA STI program, see the following:

- Access the NASA STI program home page at <http://www.sti.nasa.gov>
- E-mail your question via the Internet to help@sti.nasa.gov
- Fax your question to the NASA STI Help Desk at 443-757-5803
- Telephone the NASA STI Help Desk at 443-757-5802
- Write to:
NASA Center for AeroSpace Information (CASTI)
7115 Standard Drive
Hanover, MD 21076-1320



Radioisotope Electric Propulsion Centaur Orbiter Spacecraft Design Overview

*Steve Oleson, Melissa McGuire, Tim Sarver-Verhey, Jeff Juergens, and Tom Parkey
Glenn Research Center, Cleveland, Ohio*

*John Dankanich
Gray Research, Cleveland, Ohio*

*Doug Fiehler
ASRC Aerospace, Cleveland, Ohio*

*John Gyekenyesi and Joseph Hemminger
N&R Engineering, Cleveland, Ohio*

*Jim Gilland
Ohio Aerospace Institute, Brook Park, Ohio*

*Tony Colozza, Tom Packard, and Thahn Nguyen
Analex Corporation, Cleveland, Ohio*

*Paul Schmitz
Power Computing Solutions, Cleveland, Ohio*

*Paul Ostdiek, Rob Gold, Carey Lisse, and Karl Hibbits
Johns Hopkins University, Applied Physics Laboratory, Laurel, Maryland*

Prepared for the
44th Joint Propulsion Conference and Exhibit
cosponsored by the AIAA, ASME, SAE, and ASEE
Hartford, Connecticut, July 21–23, 2008

National Aeronautics and
Space Administration

Glenn Research Center
Cleveland, Ohio 44135

This report contains preliminary findings,
subject to revision as analysis proceeds.

Trade names and trademarks are used in this report for identification
only. Their usage does not constitute an official endorsement,
either expressed or implied, by the National Aeronautics and
Space Administration.

Level of Review: This material has been technically reviewed by technical management.

Available from

NASA Center for Aerospace Information
7115 Standard Drive
Hanover, MD 21076-1320

National Technical Information Service
5285 Port Royal Road
Springfield, VA 22161

Available electronically at <http://gltrs.grc.nasa.gov>

Contents

Abstract.....	1
I. Introduction	1
II. Assumptions and Approach	3
A. Growth, Contingency and Margin Policy.....	3
III. Mission Description	3
A. Trajectory	5
B. Mission Analysis Analytic Methods	6
1. Trojan Flyby Analysis	6
C. Mission Analysis Event Timeline	7
D. Mission Trajectory Details	7
E. Launch Vehicle Details	8
IV. Science and Science Instruments Overview.....	8
V. System Design.....	11
A. Configuration Details	11
B. MEL	12
C. Power Equipment List (PEL)	12
D. System Level Summary.....	13
E. Design Concept Drawing and Description	14
VI. Subsystem Breakdown	14
A. Attitude Control System (ACS)	14
B. Communications.....	15
C. C&DH	16
D. Avionics Trades.....	17
1. Avionics Concerns, Comments, Recommendations	17
VII. Electrical Power System.....	17
A. Power Requirements.....	17
B. ASRG Design Attributes	18
C. Power Trades.....	19
VIII. Structures and Mechanisms.....	20
IX. Propulsion and Propellant Management.....	22
A. Propulsion and Propellant Management Design and MEL	23
1. Main EP System (Xe).....	23
2. Secondary RCS System (Hydrazine)	24
B. Propulsion and Propellant Management Recommendation.....	25
X. Thermal Control	26
XI. Cost	27
Conclusions and Further Work	28
Appendix—Acronyms and Abbreviations.....	29
References.....	31

Radioisotope Electric Propulsion Centaur Orbiter Spacecraft Design Overview

Steve Oleson, Melissa McGuire,
Tim Sarver-Verhey, Jeff Juergens,
and Tom Parkey

National Aeronautics and Space Administration
Glenn Research Center
Cleveland, Ohio 44135

John Dankanich
Gray Research
Cleveland, Ohio 44135

Doug Fiehler
ASRC Aerospace
Cleveland, Ohio 44135

John Gyekenyesi and Joseph Hemminger
N&R Engineering
Cleveland, Ohio 44135

Jim Gilland
Ohio Aerospace Institute
Brook Park, Ohio 44142

Tony Colozza, Tom Packard,
and Thahn Nguyen
Analex Corporation
Cleveland, Ohio 44135

Paul Schmitz
Power Computing Solutions
Cleveland, Ohio 44135

Paul Ostdiek, Rob Gold, Carey Lisse,
and Karl Hibbits
Johns Hopkins University
Applied Physics Laboratory
Laurel, Maryland 20723

Abstract

Radioisotope electric propulsion (REP) has been shown in past studies to enable missions to outer-planetary bodies including the orbiting of Centaur asteroids. Key to the feasibility for REP missions are long life, low power electric propulsion (EP) devices, low mass radioisotope power systems (RPS) and light spacecraft (S/C) components. In order to determine what are the key parameters for EP devices to perform these REP missions a design study was completed to design an REP S/C to orbit a Centaur in a New Frontiers cost cap. The design shows that an orbiter using several long lived (~200 kg Xenon throughput), low power (~700 W) Hall thrusters teamed with six (150 W each) Advanced Stirling Radioisotope Generators (ASRG) can deliver 60 kg of science instruments to a Centaur in 10 yr within the New Frontiers cost cap. Optimal specific impulses for the Hall thrusters were found to be around 2000 sec with thruster efficiencies over 40%. Not only can the REP S/C enable orbiting a Centaur (when compared to an all chemical mission only capable of flybys) but the additional power from the REP system can be reused to enhance science and simplify communications.

I. Introduction

The Collaborative Modeling and Parametric Assessment of Space Systems (COMPASS) team was approached by the NASA In-Space Project to perform a design session to develop REP S/C Conceptual Designs (with Cost/Risk/Reliability) for missions of three different classes: New Frontiers Class Centaur Orbiter (with Trojan Flyby), Flagship, and Discovery Class. (COMPASS is a multidisciplinary collaborative engineering team whose primary purpose is to perform integrated vehicle systems analysis and provide trades and designs for both Exploration and Space Science Missions.) The designs will allow trading of current and future propulsion systems. The results will directly support technology development decisions. The mission class documented in this final report is the New Frontiers class orbiter mission to a Centaur body, with a Trojan flyby along the trajectory.

Past studies have shown that REP can enable orbiters for outer planetary small bodies.¹⁻⁶ The mission design detailed in this report is an REP powered EP science orbiter to the Centaur Thereus with arrival

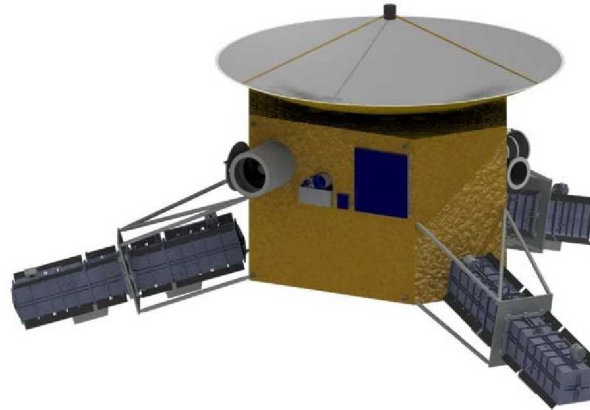

Figure 1.—Conceptual REP Science S/C

10 yr after launch. Along the trajectory, approximately 1.5 yr into the mission, the REP S/C does a flyby of the Trojan asteroid, Tlepolemus. The total ΔV of the trajectory is 8.4 km/s. The REP S/C is delivered to orbit on an Atlas 551 class launch vehicle with a Star 48 B solid rocket stage. Figure 1 shows the conceptual S/C reported on in this document.

Table 1 summarizes the REP S/C and mission. It is evident that the largest systems are power and propulsion, which enable the timely mission to orbit a Centaur. While the power is more abundant than usual for S/C of this class, it is not large. The additional power used for transit is available for science and communications at the Centaur. Preliminary assessments point towards the use of higher power communications to reduce Deep Space Network time (DSN) and reduce operations costs.

TABLE 1.—MISSION AND S/C SUMMARY

Mission	10 yr mission, orbit Centaur (Thereus) in 9 yr, flyby Trojan (Tlepolemus) in 1.5 yr, 8.4 km/s	Total mass with growth
Launch	Atlas 551/Star 48, C_3 97.28 km ² /s ²	1260 kg (wet)
Science	Six instruments consuming 60 W, remote imaging (WAC and NAC cameras, LIDAR, near-IR spectral mapping) and in-situ sampling (NIGMS, DFM), 130 Mb per day	57 kg
Power	Six ASRGs with multilayer insulation (MLI), attached (loaded) in pairs, 900 W end of life (EOL) (10-yr)	199 kg
Propulsion	Primary electric: 3+1 Long Life Hall Thrusters, operated serially, 500 kg Xe propellant load, 650 W into thruster, 1920 sec Isp, 170 kg Xe throughput each, single string Power Processing Units (PPU) (95%), thruster feed, thruster 30,000 hr Secondary chemical: Blowdown hydrazine, 28 kg propellant, 8 of 0.25 lbf thrusters	137 kg
Mechanical	Hexagonal Al-Li bus with propulsion and science decks, capable of carrying 6 g launch loads	118 kg
Communications	220 W, 8 kb/s Data rate, Ka Band, 2.1 m antenna	52 kg
Command and Data Handling (C&DH)	RAD 750 computer with 16 GB storage capacity	45 kg
Attitude Determination and Control (AD&C)	2 Star cameras, Inertial Measurement Unit (IMU), 4 reaction wheels, hydrazine propulsion	22 kg
Thermal	MLI and heaters, ASRG isolated	49 kg

The main design challenge for an REP S/C is minimizing S/C masses while integrating a significant Xe propellant and multiple RPS. Fortunately, Xe propellant is very dense and can be stored in carbon fiber overwrapped tanks. The selected RPS was ASRG due to their high efficiency and subsequently small plutonium load for the power delivered. The best balance of power and thrust was found to be around 900 W EOL, with 700 W being fed to the electric thruster power processors. The remaining 200 W was for housekeeping. This power requirement was provided by six ASRGs, each containing about 0.9 kg of plutonium for a total of 5.4 kg. By comparison the New Horizons (NH) S/C, using an 80% loaded RTG had 11 kg of plutonium.

Besides the obvious advantage of enabling orbiting a Centaur, the REP approach also provides much more power to the science and communications system once the asteroid is reached when compared to a chemical flyby system. During this design it was found that the power was actually more valuable to the communication system. While additional power for science will require additional mass allowance, the communication and data storage systems and operations can be reduced by allowing for higher power communications and either a smaller antenna or reduced DSN time.

The goal of the REP science S/C is to send a science payload to a Centaur class body. The Centaurs are planetary bodies in orbit about the Sun and located between the orbits of Jupiter and Neptune. These bodies are typically asteroidal to comet-like in appearance and physical makeup. If possible, the mission flight plan will include a flyby of one of the Jupiter Trojan asteroids. The Trojan asteroids occupy one of the Lagrange points created by Jupiter and the Sun.

The science mission objective is to determine the origin and evolution of Centaurs and Trojan bodies. For example: What is the density, volume, rotation state, albedo of the “typical” Centaur? Are Centaurs the direct descendants of Kuiper Belt Objects (KBOs)? How do Centaurs compare to the icy small satellites of Saturn (Phoebe, Hyperion) that are supposedly KBOs?

II. Assumptions and Approach

The following section contains the mission description of the class of mission being designed in this REP study. All the following details are the most current available at the time of this design session. This study is focusing on a New Frontiers Class Mission design.⁷⁻⁹

A. Growth, Contingency and Margin Policy

Mass Growth: For dry mass elements in the system design, the COMPASS team uses the AIAA–R–020A–1999, *Recommended Practice for Mass Properties Control for Satellites, Missiles, and Launch Vehicles*.¹¹

AIAA–R–020A–1999 provides percent mass growth specified by level of design maturity and specific subsystem. The percent growth factors are applied to each subsystem, after which the total system growth of at the vehicle level is calculated. The COMPASS team desired total growth to be 30%, and an additional growth is carried at the system level in order to achieve a total system growth of a 30% limit on the dry mass of the system. Note that for designs requiring propellant, growth in propellant is either book kept in the propellant itself or in the ΔV used to calculate the propellant necessary to fly a mission.

The COMPASS team uses the Discover Announcement of Opportunity (AO) definitions of contingency and mass margin. A launch margin of 10% is assumed for the launch system. The COMPASS team uses a 30% margin on the bottoms up power requirements in modeling the power system except for EP power. A margin of 30% on this power would require an excessive increase in power system mass. Consequently, lower power trajectories are considered to handle degradation of power to the electric thrusters. See Section VII for the power system assumptions.

III. Mission Description

The primary requirement for the mission is orbit a Centaur class body in the minimum amount of time while delivering the maximum payload. Along the trajectory, a flyby of a Trojan asteroid was incorporated into the mission profile to provide early science opportunity and provide comparison between Trojans and Centaurs. The representative Centaur body chosen for the mission was Thereus. Thereus was found to be representative of several Centaur targets in terms of required delivery ΔV . A complete description of the mission design and trades can be found in AIAA–2008–4518.

Figure 2 shows the grouping of Centaur objects in the solar system region around Saturn, Uranus, and Neptune. The orbits of the known Centaurs and Neptune Trojans are show in Green. (Graphic taken from wikipedia.org⁶). The inclination of the orbit is the Y-axis. Using this mapping of Centaur bodies, and the

low thrust mission analysis code Varitop, a suite of trajectories to Centaur bodies was flown to find a mission that would fit the science requirements and deliver the inert mass from the bottoms up S/C system design.

While the initial Centaur body selection is done over a wide range of bodies, the iterative process of mission and system design done during the design session limits the selection of Centaur bodies to those who's trajectory C_3 is similar to the performance C_3 of the Expendable Launch Vehicle (ELV) (Atlas 551/Star 48B) to accommodate the inert mass of the S/C design.

Next, Figure 3 shows the Centaur body target comparison in terms of mission performance parameters of launch mass, necessary propellant mass and delivered payload mass to the target, as well as total mission ΔV . The two red-boxed areas are the potential target centaurs that fit within the initial assumed performance of the REP S/C and thrusters.

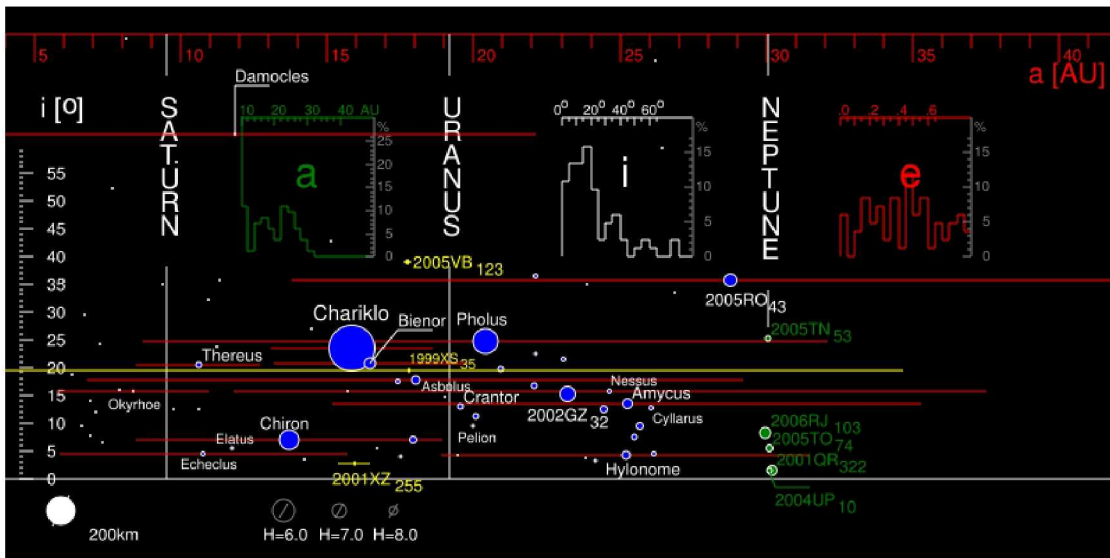

Figure 2.—Centaur Body Distribution.

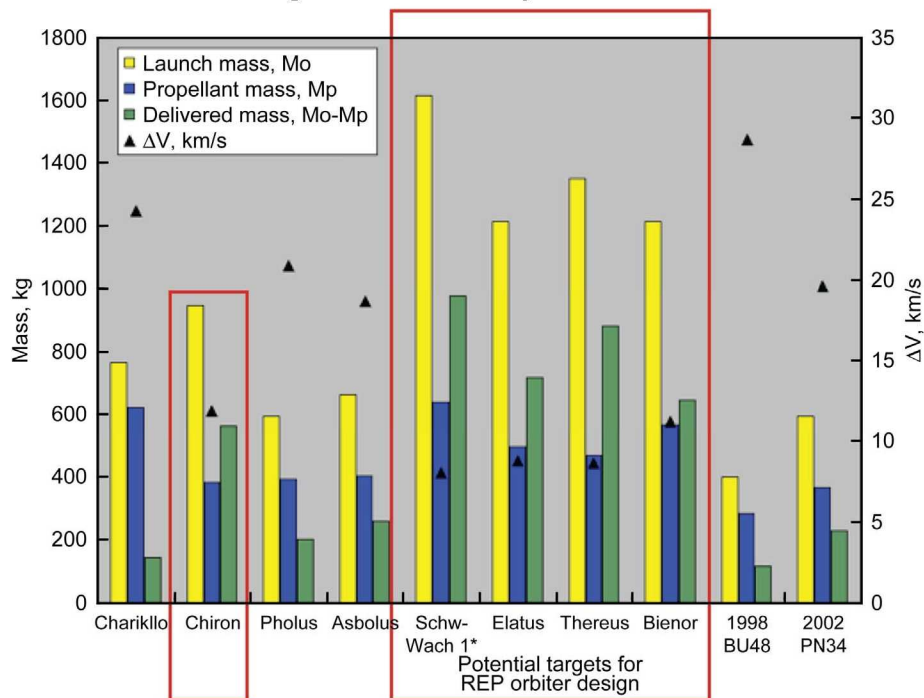

Figure 3.—Performance comparison.

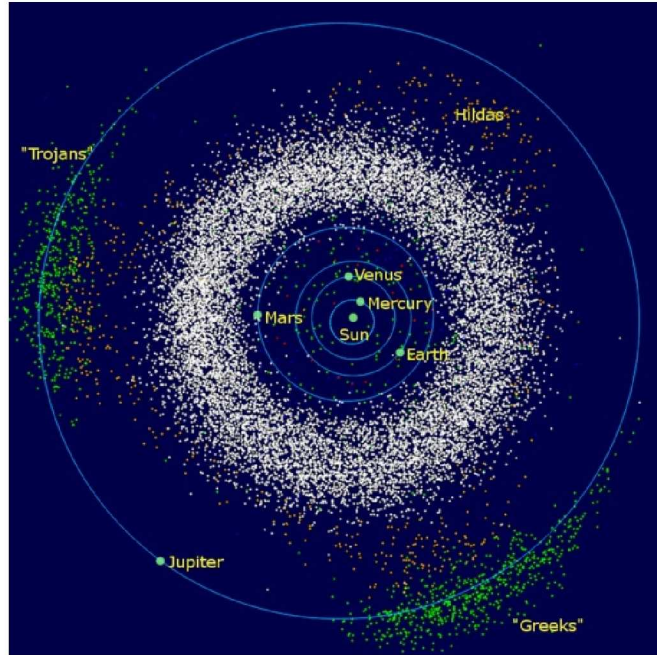

Figure 4.—Distribution of Trojan Asteroids in Jupiter's Orbit.

Figure 4 shows the distribution of the Trojan asteroids in the orbit of Jupiter.⁷ The clusters of green objects located behind Jupiter in its orbit are the Trojans, and the clusters in front of Jupiter in its orbit are the Greeks. Both areas in the Jovian orbit have been added into the trade space of objects to flyby along the way to the Centaur object.

A. Trajectory

The Centaur, Thereus, was chosen as representative of Centaurs parameters. There is no coast phase in the mission but a 10% thrust margin is included in the analysis. The baseline trajectory parameters for the Thereus trajectory were:

- Launch Mass (Mo): 1260.2 kg (Atlas 551 performance to C₃)
- C₃: 97.28 km²/s²
- Launch date: November 15, 2024
- Fly-by date: August 7, 2026
- Arrival date: November 13, 2034
- Power: 650 W
- Specific Impulse: 2057 s
- ΔV: 8.93 km/s
- Propellant (Mp): 450.8 kg (used to perform ΔV)
- Mo – Mp: (1260 – 450) 809 kg
- Fly-by Target: Tlepolemus

This trajectory allowed for an REP inert mass of 809 kg. This inert mass includes the residuals and margin in the Xe propellant. The 450 kg is the ideal Xe propellant used to fly the ideal trajectory ΔV. With the 30% margin, and the extra Reaction Control System (RCS) propellant, which is not modeled in the ideal ΔV modeling via the low thrust trajectory, the REP S/C was able to fit inside this “inert” mass box. (See Table 7 to see the system masses, with margin, and S/C adapter to come up with the launch margin for the REP S/C.)

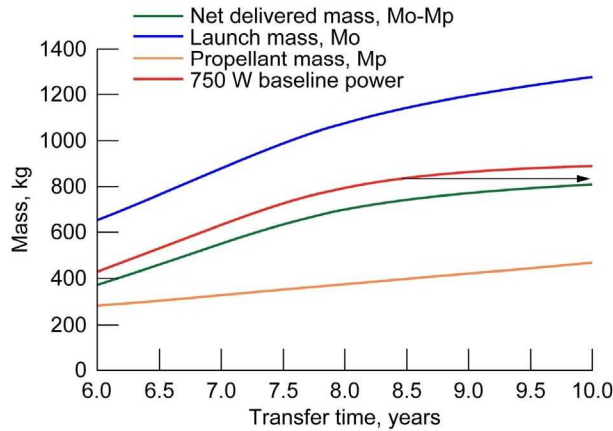

Figure 5.—Net Mass Delivered Versus Transfer Time

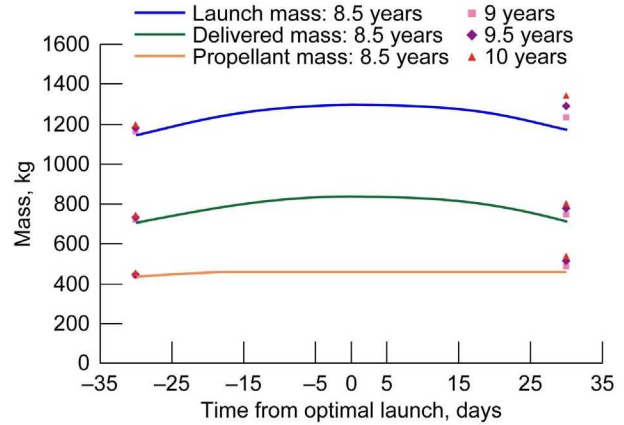

Figure 6.—Launch Window Analysis

Figure 6 shows the launch window analysis on the baseline Thereus trajectory. A 10-day launch window will result in minimal impact to the trajectory. A 20-day launch window may require slightly longer trip time. Re-optimizing the trajectory to include coast periods could alleviate this issue.

B. Mission Analysis Analytic Methods

The low thrust mission analysis performed for this mission was done using the low thrust optimization code Varitop, developed at the NASA Jet Propulsion Laboratory (JPL). Typically a maximum duty cycle of 90% is imposed on the trajectory optimization using the updated Septop. Because Varitop does not have that feature, the thrust and therefore efficiency was reduced to 90% of the anticipated performance. This interjected 10% thrust margin artificially puts 10% coasting times into the trajectory to alleviate the launch window analysis implications in Figure 6. The optimization parameters for running this trajectory are listed in Table 2.

TABLE 2.—MISSION ANALYSIS ASSUMPTIONS

Launch vehicle	Atlas 551 w/ Star 48	Optimized
Launch vehicle contingency	10%	Fixed
Epoch date	April 22, 2024	Fixed
Launch date	November 15, 2024	Optimized
Mission duration	10 yr	Fixed
Thruster power	750 W	Fixed
Thruster efficiency	Hall Curve	Fixed
Specific impulse	1800 s	Fixed

The thruster performance was modeled using the thruster curves shown in Figure 7. These are based on a single operating point thruster performance estimates provided by the NASA Glenn Research Center’s (GRC) Electric Propulsion Division. The specific impulse and sensitivity was initially optimized for the mission and then was fixed for parametric analyses on the chosen system.

1. Trojan Flyby Analysis

Given the launch dates for the optimal Thereus trajectory, the possibility of encountering a Trojan asteroid are greater for the Thereus mission than they were for the Bienor mission. Figure 8 shows the potential Trojan flybys as the REP science S/C passes through the asteroid belt. It can be seen that multiple Trojans are within flyby range without any targeting necessary by the S/C, and therefore, without extra propellant budgeting necessary.

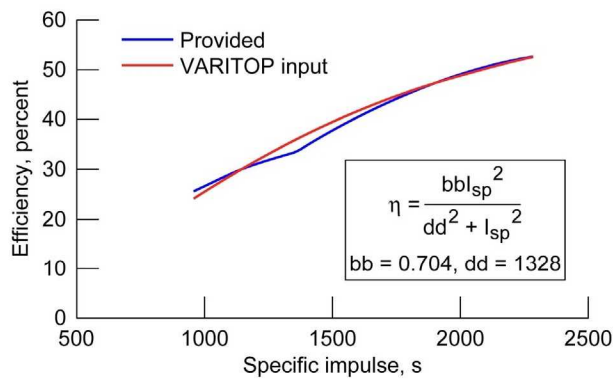

Figure 7.—Thruster Performance Modeling Assumptions

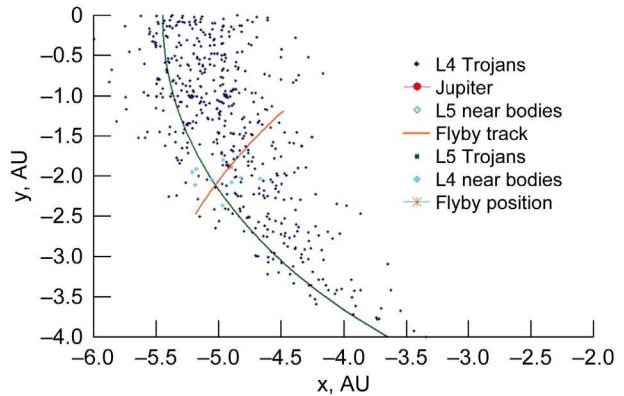

Figure 8.—Potential Trojan Flybys Along Trajectory

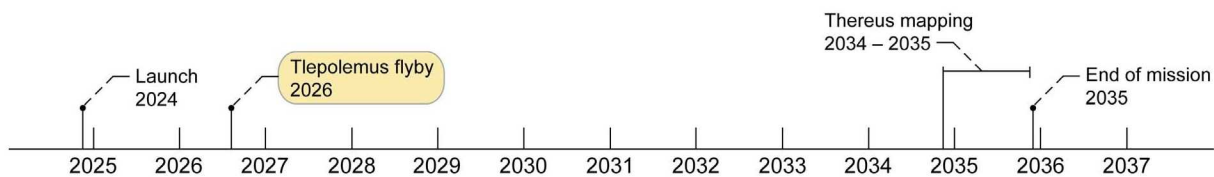

Figure 9.—Mission timeline.

Based on the available Trojan asteroids during the flyby, the Trojan, Tlepolemus, was chosen as the flyby target. Tlepolemos is the named Trojan nearest to the Earth in an orbit closer than any other of the Trojans to Earth’s orbit.

C. Mission Analysis Event Timeline

- Launch date: November 15, 2024
- Fly-by Trojan date: August 7, 2026
- Arrival at Centaur date: November 13, 2034

A benefit of this mission and trajectory is that First Science with a Trojan Flyby is available less than 2 yr after launch. This allows for testing of the science instruments for the final Centaur mission along with the capture of interesting science data of a Trojan asteroid. Figure 9 shows the relative mission timeline of the major events in the mission: Trojan flyby, Centaur body arrival and science mapping.

D. Mission Trajectory Details

Figure 10 shows the trajectory to Thereus with a flyby of the Trojan asteroid Tlepolemus. Note that that orbit in blue is the “circular” orbit of the Earth about the Sun. The green orbit is the Trojan asteroid belt, and the aqua blue orbit is that of the Centaur body Thereus. The small triangle on the orbit of Thereus indicates perihelion. The goal of the arrival at Thereus is to arrive at the Centaur body prior to its perihelion, in order to take science data at the Centaur as it goes through its closest approach to the Sun and encounters its maximum temperatures and has the highest probability of activity.

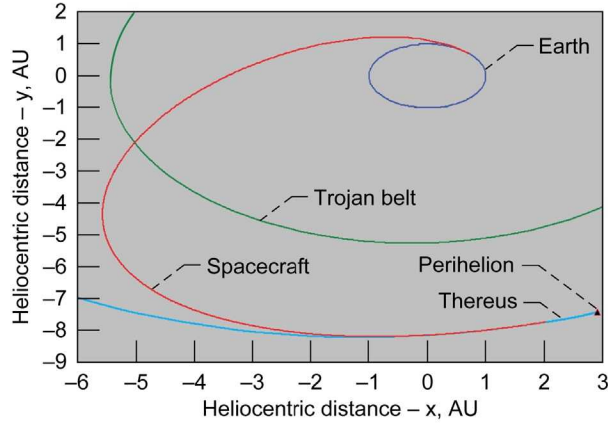

Figure 10.—Trajectory from Earth to Thereus with Trojan Asteroid flyby.

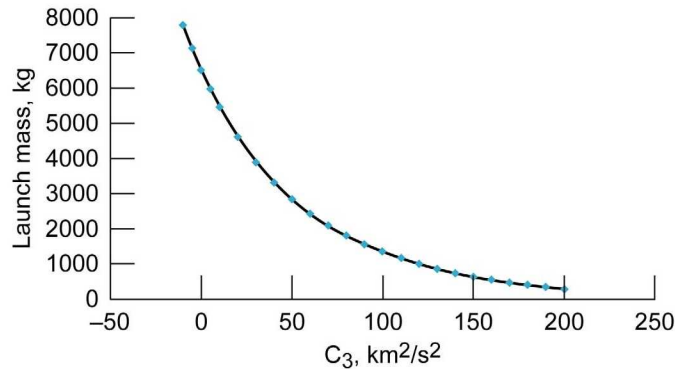

Figure 11.—Launch mass versus C_3 .

The Concept of Operations (CONOPS) of the mission is based on that of the Deep Space One mission that validated EP technology with the flight of the NSTAR engine.⁸⁻⁹ The Ground Trajectory Planning updates monthly. Orbit Determination occurs weekly via an on-board camera every 4 to 6 hr. The “Autonav” system can overwrite, during retargeting, a real-time ephemeris, schedules, and executes events and navigation update computations. The Reduced State Encounter Navigation (RSEN) operations mode begins several hours prior to encounters and maintains visual lock from the Earth to the REP S/C.

E. Launch Vehicle Details

The baseline Launch Vehicle is the Atlas 551 with a Star 48 solid propellant upper stage. The Launch Vehicle performance versus launch C_3 is shown in Figure 11. The launch vehicle contingency was assumed to be 10%, and was generated using the low thrust trajectory code Varitop. This data assumed that the Star 48 had already performed its burn. Consequently, the mass of the Star 48 will not be included in the REP S/C MEL.

Figure 12 shows the packaging of the REP S/C and Star 48 engine in the Atlas 551 short 5 m payload fairing. Note that the Atlas V payload shroud volume more than accommodates the REP Science orbiter S/C, leaving plenty of room for design changes such as the antenna diameter or number of ASRGs.

IV. Science and Science Instruments Overview

The initial desired science payload from the Applied Physics Laboratory (APL) consisted of six core instruments base-lined for the Centaur REP mission study. The instruments in order of priority are: (1)

LORRI (imager); (2) New THEMIS (thermal mapping); (3) LIDAR (ranging and topography); (4) NGIMS (gas spectrometer); 5) WAC; and 6) NIMS. The instruments are not required to have a separate processor and will interface directly with the Main Processor of the REP Bus because Centaurs cross the orbits of the planets, their own orbits are unstable, evolving rapidly. This makes the Centaur mission a challenging one. However, in doing the design, the science instrument NGIMS was removed from the package to save on mass, cost and power.

The proposed mission includes a flyby of a Trojan asteroid with limited science to be performed during that flyby. Once at the Centaur body, up to a year of science mission operations will be performed. Therefore, there must be enough power and attitude control propellant to sustain the vehicle for that amount of time.

Table 3 lists the major details (mass, power, cost, etc.) of the six science instruments developed by APL for inclusion on the REP Centaur conceptual S/C being designed in this session. Note that not all of the instruments were used in this design in order to save on mass. Table 4 lists the MEL for the science instruments as modeled in the COMPASS design session.

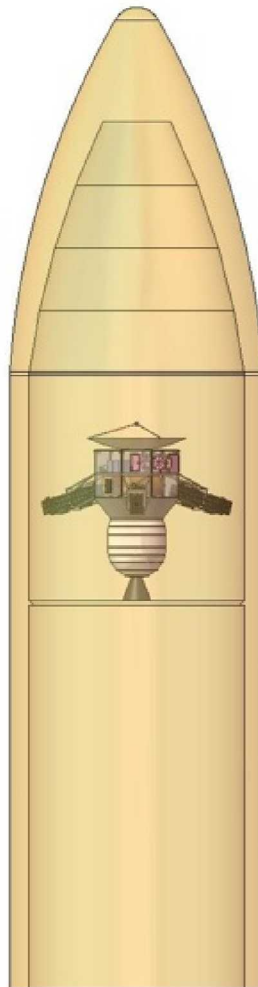

Figure 12.—REP S/C in Atlas 551 Payload Shroud.

TABLE 3.—SCIENCE INSTRUMENTS FOR CENTAUR MISSION

Instrument name	Mass (kg)	Power (W)	Dimensions (cm)	Output data rate
LORRI	8.32	2.11	62 by 48 by 35.5	12.6 Mbps
WAC	0.6	4	14.5 by 9.2 by 7.6	??
NIMS	18	12 W average 13 W peak	83 by 37 by 39 (optics) 20 by 25 by 13 (electronics)	11.52 kbps
LIDAR	5	16.5 W average 20.7 peak	37.5 by 21.6 by 22.9	51 bps
NGIMS	10.50	24	19 by 24.7 by 36.2	1.5 Kbps

*(A total of 13 Mbits/day will be baselined and allocated between the instruments)

TABLE 4.—REP SCIENCE S/C TOP LEVEL BOTTOMS-UP MASTER EQUIPMENT LIST (MEL)

Description	QTY	Unit Mass	CBE Mass	Growth	Growth	Total Mass
REP Centaur Mission 6ASRG (10-11-2007)		(kg)	(kg)	(%)	(kg)	(kg)
REP Spacecraft (Payload and Stage)			1071.00	11.68%	125.14	1196.14
Science Payload			44.12	30.00%	13.24	57.36
APL Science Instruments			25.52	30.00%	7.66	33.18
LORRI	1	8.32	8.32	30.00%	2.50	10.82
misc.	1	12.2	12.20	30.00%	3.66	15.86
LIDAR	1	5.0	5.00	30.00%	1.50	6.50
NGIMS	0	10.5	0.00	30.00%	0.00	0.00
Additional Science Instruments			18.60	30.00%	5.58	24.18
WAC	1	0.60	0.60	30.00%	0.18	0.78
NIMS	1	18.00	18.00	30.00%	5.40	23.40

The science CONOPS is as follows:

Orbital CONOPS:

- The S/C will orbit the Centaur Body for 1 yr
- The S/C will orbit the body in the plane of Earth’s sky (i.e., the S/C will always be able to communicate with the Earth and will not eclipse behind the body)
- Upon approach to the body, the LORRI instrument will be required to capture at least two optical navigation images per day
- The minimum daily science collection will be 130 Mb while in orbit
 - The instruments and recorder allow for a higher collection rate if desired
- Primary ground contact operations concept:
 - Three 8 hr contacts per week using the DSN—70 m Dish, yields 24 hr/week of contact time
 - Translates into ~19.5 hr/week of actual downlink time (6.5 hr/contact)
 - Possible ~1 Gbits/day of science/housekeeping collection
- Assumed minimum 45 kbits/s downlink at 70 m dish with 100 W of radio frequency (RF) radiated power
 - DSN Total 1 yr Orbital Cost: FY07 \$7.4M [\$23M for 1 yr of 7 tracks per week]

Trojan flyby CONOPS:

- Science collection at the Trojan flyby consists of two data collection periods:
 - For 10 days leading up to closest approach to the asteroid, the LORRI instrument will be capturing at least 6 images per day

- Assume 50% duty cycle of the EP thrusters during this time
 - The 3 days of closest approach (1 day before, 1 day during, 1 day after) will consist of all instruments collecting data
- Assume 0% duty cycle of the EP thrusters during this time
 - It is estimated that ~ 8 Gbits of science data will be collected during the entire flyby
- Total non-thrusting period during asteroid flyby would be approximately 12 days broken down as follows:
 - 5 days of non-thrusting leading up to closest approach
 - 3 days of non-thrusting during closest approach
 - 52 hr of data downlink for 8 Gbits during nonthrusting periods
- Assume 70 m dish and S/C can downlink at minimum 45 kbits/s
 - 2 days of contingency

V. System Design

Figure 13 shows the basic design of the Centaur REP driven S/C. From the top down in this diagram, the REP S/C consists of a 2.1 m antenna dish located on the top for relay to the DSN. Below the dish sits the payload deck where the science instruments (shown in purple and grey) and avionics instruments are mounted. There are six ASRG units, mounted by twos (dark blue grey) to the S/C bus superstructure, all pointing out perpendicularly from the main body of the S/C, two Xe tanks (orange), a He pressurization tank, four Xe Hall EP Thrusters, and a Star 48 solid rocket engine sitting directly below the propellant management equipment. This stack will be mounted in the Atlas 551 payload fairing.

The REP S/C will be launched on an Atlas 551 with Star 48 Upper Stage (similar to NH launch). The payload will be located in the middle of the REP/Star 48 motor stack just below the antenna dish. To first order, the S/C configuration is built around the following major components:

A. Configuration Details

- Bottom propulsion/power deck
 - ~500 kg of Xe in two Composite Overwrapped Pressure Vessel (COPV) tanks
 - Six advanced RPS
- Stacked by twos
- Supported by ends with plate struts

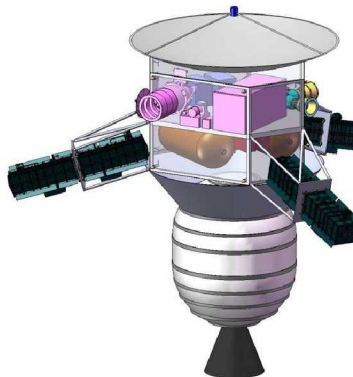

Figure 13.—Baseline Conceptual REP S/C Design on Top of Star 48 Rocket Motor

- Three or more advanced Hall or Ion propulsion systems
- Thrusting mostly tangential
 - Hydrazine secondary propulsion system
- Top payload/avionics deck
 - 2.1 m dish antenna
 - Four Science payloads—side pointing
 - Avionics/Communications/Guidance, Navigation and Control (GN&C)
- Bottom launch vehicle interface

B. MEL

The Bottoms-Up MEL for the final six ASRG mission designed is shown in Table 5.

TABLE 5.—MEL

Description	QTY	Unit Mass	CBE Mass	Growth	Growth	Total Mass
REP Centaur Mission 6ASRG (10-11-2007)		(kg)	(kg)	(%)	(kg)	(kg)
REP Spacecraft (Payload and Stage)			1071.00	11.68%	125.14	1196.14
Science Payload			44.12	30.00%	13.24	57.36
REP Bus			1026.88	10.90%	111.91	1138.79
Attitude Determination and Control			18.40	20.00%	3.68	22.08
Command and Data Handling			33.30	34.26%	11.41	44.71
Communications and Tracking			39.00	34.10%	13.30	52.30
Electrical Power Subsystem			169.82	16.97%	28.82	198.64
Thermal Control (Non-Propellant)			42.81	15.00%	6.42	49.23
Propulsion			107.99	26.56%	28.68	136.67
Propellant			517.57	0.00%	0.00	517.57
Structures and Mechanisms			97.99	20.00%	19.60	117.59

C. Power Equipment List (PEL)

The power listing for nominal loads is modeled using a 900 W max power (with 30% margin on all but EP system) budget. A 30% margin is added on all but REP systems (thruster able to handle lower powers down to 500 W). Table 6 lists the concepts of operations and what items are turned on at which point on the mission trajectory. The PEL clearly shows that at least 200 W (including margin) will be needed for S/C during EP thrusting.

TABLE 6.—PEL PER SUBSYSTEM OVER MISSION PHASES

	Propulsion (W)	Avionics (W)	Comm. (W)	Thermal (W)	GN&C (W)	Power (W)	Science (W)	CBE total (W)	30 % margin	Total (W)
Launch	0	24	0	33	27	63	0	146	48.63	195
Star 48 Operation	0	24	420	33	27	63	0	566	174.63	741
S/C separation	16	24	420	33	27	63	0	582	174.63	757
S/C checkout	16	24	420	33	36	63	60	652	195.48	847
REP thrusting	700	24	0	33	29	63	2	850	49.86	900
REP coast	16	24	0	33	29	63	2	166	49.86	216
Communications	16	53	420	33	29	63	2	615	184.44	799
Flyby	16	53	420	33	29	63	60	673	201.87	875
Centaur targeting	700	24	0	33	29	63	2	850	49.86	900
Centaur science	16	53	0	33	29	63	60	253	75.87	329
Centaur communications	16	53	420	33	29	63	60	673	201.87	875

TABLE 7.—SYSTEM INTEGRATION SUMMARY SHEET: SYSTEM LEVEL GROWTH TRACKING

COMPASS study: Radioisotope Electric Propulsion (REP)			Study Date	11/26/07	
GLIDE container: REP_Sept2007: Thereus_6ASRG			COMPASS REP Design		
REP Spacecraft Master Equipment List Rack-up (Mass)					
WBS	Main Subsystems	CBE Mass (lkg)	Growth (kg)	Total Mass (kg)	Aggregate Growth (%)
01	REP Spacecraft (payload and bus)	1071.0	125.1	1196.1	
01.1	Science Payload	44.1	13.2	57.4	30.0%
01.2	REP Bus	1026.9	111.9	1138.8	
01.2.1	Attitude Determination and Control	18.4	3.7	22.1	20.0%
01.2.2	Command and Data Handling	33.3	11.4	44.7	34.3%
01.2.3	Communications and Tracking	39.0	13.3	52.3	34.1%
01.2.4	Electric Power	169.8	28.8	198.6	17.0%
01.2.5	Thermal Control	42.8	6.4	49.2	15.0%
01.2.6	Propulsion	108.0	28.7	136.7	26.6%
01.2.7	Propellant	517.6			
01.2.8	Structures and Mechanisms	98.0	19.6	117.6	20.0%
Estimated REP Spacecraft Dry Mass		553	125	678.6	22.6%
Estimated REP Spacecraft Wet Mass		1071	125	1196.1	
System Level Growth Calculations				Total Growth	
Desired System Level Growth		553	166	719.5	30.0%
Additional Growth (carried at system level)			41		7.4%
Total Wet Mass with Growth		1071	166	1237.0	
Available Launch Performance to C3 (kg)				1250.2	
Launch margin available (kg)				13.2	

D. System Level Summary

Table 7 breaks out the system level summary of the REP S/C designed in this COMPASS session. The bottoms up masses of the subsystem with the growth estimates applied per line item in the subsystem yielded a total growth on the dry mass of 22.6%. Since the desired total growth is 30% per COMPASS operating procedure, an additional 7.4% of dry mass is carried as system level growth. This mass is “flown” through the mission, and adds to the inert mass that the propulsion system has to push around with the trajectory ΔV .

The performance of the Atlas 551 launch vehicle to the mission C_3 of $97 \text{ km}^2/\text{s}^2$ is 1260 kg. A S/C adapter mass of 10 kg is taken out of that number to give the available launch performance of 1250 kg to the C_3 as reported in Table 7. The total wet mass of the S/C of 1237 kg is subtracted from the available launch performance. The remaining 13 kg is the launch margin available.

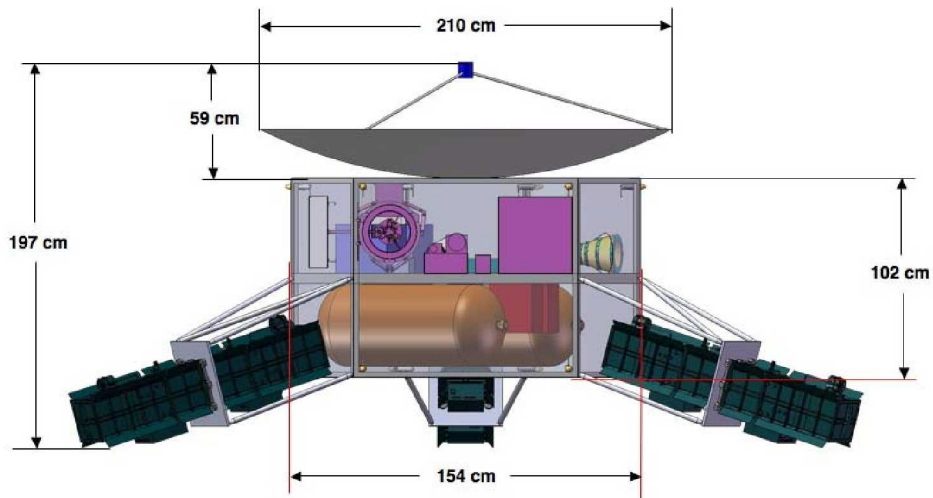

Figure 14.—REP Science S/C Dimensions

E. Design Concept Drawing and Description

Figure 14 shows a side view of the REP Centaur S/C, without the Star 48 engine attached with dimensions. All dimensions are in metric units.

VI. Subsystem Breakdown

A. Attitude Control System (ACS)

The starting design is borrowed from NH:

- ACS hydrazine
- Two Star Trackers (Adcole Corporation¹⁰). These star trackers were the ones used on the NH S/C
- Eight Sun Sensors (EDO Corporation, Barnes Engineering Division)
- Four Reaction Wheels (Valley Forge Bearcat 5 Nms reaction wheel¹¹)
- GN&C software run on main C&DH computers

Table 8 lists the items in the ACS MEL for the COMPASS REP S/C design. All growth allowances follow the AIAA mass growth allowance (MGA) schedule in Section II.A.

Figure 15 shows the avionics deck of the REP S/C. This deck is where all the electronics are located. The graphic has all non-electronics items in the S/C invisible, and highlights the components of Avionics, ACS, Power and Communications, aside from the main antenna, and the science instruments (all labeled at the bottom of the graphic).

Analysis into the amount of ΔV necessary for station keeping and attitude control throughout the mission life needs to be performed to determine whether the 50 m/s assumption is sufficient. Additionally, further research is necessary to determine whether the star trackers and sun sensors are capable of operating at the distances of the Centaur bodies at the EOL of the trajectory.

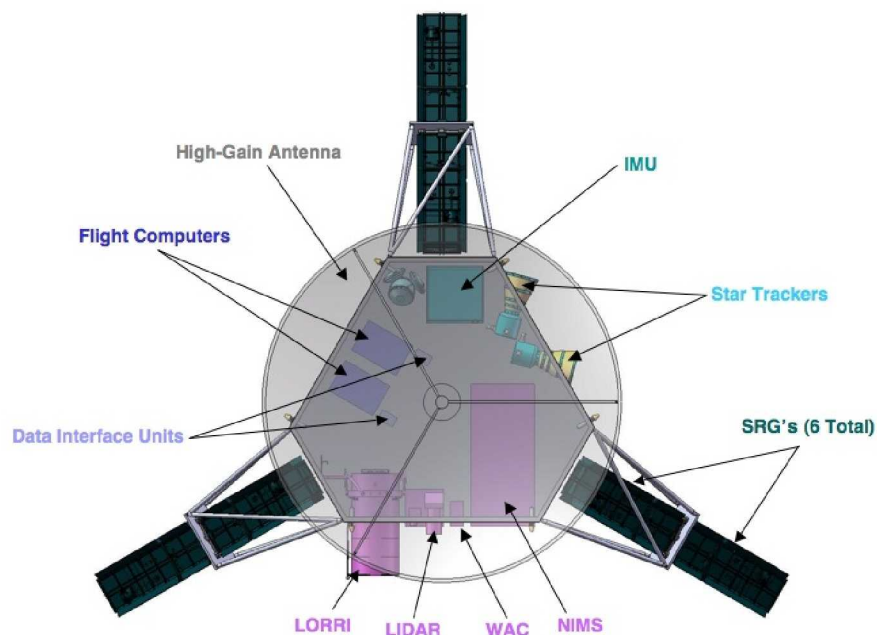

Figure 15.—Science and Avionics Deck of REP S/C

TABLE 8.—ACS BOTTOMS-UP MEL

Description	QTY	Unit Mass	CBE Mass	Growth	Growth	Total Mass
		(kg)	(kg)	(%)	(kg)	(kg)
REP Centaur Mission 6ASRG (10-11-2007)						
REP Spacecraft (Payload and Stage)			1071.00	11.68%	125.14	1196.14
REP Bus			1026.88	10.90%	111.91	1138.79
Attitude Determination and Control			18.40	20.00%	3.68	22.08
Guidance, Navigation, & Control			18.40	20.00%	3.68	22.08
Sun Sensors	8	0.01	0.04	20.00%	0.01	0.05
Reaction Wheels	4	1.27	5.08	20.00%	1.02	6.10
Star Trackers	2	3.19	6.38	20.00%	1.28	7.66
IMU	1	6.90	6.90	20.00%	1.38	8.28

B. Communications

Provide uplink and downlink capability throughout the primary and/or extended mission. Meet science mission requirements of 8 hr/day of downlink pointed to Earth with a minimum 6.3 kbps downlink at 34-m disk (or about 147 Mbits/day of downlink including a minimum of 10% for housekeeping).

Assume DSN will be capable of supporting Ka-Band downlink via 70-m or 34-m antenna by 2024. The design is based on the NH concept of two onboard radioisotope power systems (IEMs). The overall harness requirements are reduced if the NH IEM design is implemented.

- REP orbiter communications subsystem consists of
 - A fixed 2.1-m diameter X/Ka-Band high gain antenna (HGA)
 - Two IEMs, based on the NH, housing many S/C functions, including C&DH, instrument interface circuitry, telemetry interface, solid state recorder, and receiver and exciter sections of the communications subsystem
 - Two 200-W Traveling Wave Tube Amplifier (TWTA) to provide high power RF (downlink output)
 - RF switch assembly to interconnect antenna with two TWTAs and the rest of communications subsystem
 - Cabling
- Ka-Band downlink to 34-m ground stations
 - Ka-Band downlink frequency: 32 GHz
- X-Band support between orbiter and Earth’s 34-m and 70-m ground stations
 - Forward frequency: 8.4 GHz
 - Return frequency: 7.75 GHz
 - Use of a fixed 2.1-m HGA
 - 200 W RF power
 - TT&C will share the uplink and downlink bandwidth

Table 9 lists the items in the Communications system MEL for the COMPASS REP S/C design. All growth allowances follow the AIAA MGA schedule in Section II.A, and do not contain the additional 8.8% carried at the system level.

TABLE 9.—REP COMMUNICATIONS SYSTEM MEL

Description	QTY	Unit Mass	CBE Mass	Growth	Growth	Total Mass
		(kg)	(kg)	(%)	(kg)	(kg)
REP Centaur Mission 6ASRG (10-11-2007)						
REP Spacecraft (Payload and Stage)			1071.00	11.68%	125.14	1196.14
REP Bus			1026.88	10.90%	111.91	1138.79
Communications and Tracking			39.00	34.10%	13.30	52.30
X/Ka High Gain Antenna			27.00	31.48%	8.50	35.50
Transmitter/Receiver	2	4.00	8.00	30.00%	2.40	10.40
Power Amp	2	3.00	6.00	30.00%	1.80	7.80
Switch Unit	0	0.00	0.00	0.00%	0.00	0.00
Antenna	1	9.00	9.00	30.00%	2.70	11.70
Band Pass Filter	0	0.00	0.00	0.00%	0.00	0.00
Band Reject Filter	0	0.00	0.00	0.00%	0.00	0.00
Sensor	0	0.00	0.00	0.00%	0.00	0.00
Cabling	2	2.00	4.00	40.00%	1.60	5.60
Diplexer	0	0.00	0.00	0.00%	0.00	0.00
Coupler	0	0.00	0.00	0.00%	0.00	0.00
Misc#1	0	0.00	0.00	0.00%	0.00	0.00
Misc#2	0	0.00	0.00	0.00%	0.00	0.00
Ka-band Antenna			0.00	0.00%	0.00	0.00
Transponder	0	0.00	0.00	0.00%	0.00	0.00
RF Assembly	0	0.00	0.00	0.00%	0.00	0.00
Processing Module	0	0.00	0.00	0.00%	0.00	0.00
Antenna	0	0.00	0.00	0.00%	0.00	0.00
Communications Instrumentation			12.00	40.00%	4.80	16.80
Coaxial Cable	2	6.00	12.00	40.00%	4.80	16.80
Installation - Mounting & Circuitry	0	0.00	0.00	0.00%	0.00	0.00

C. C&DH

The design requirements and assumptions, from the science payload and the REP Bus, for the C&DH system were as follows:

- Storage for 7 days of data or fly-by (estimated 16 GB)
- Avionics for systems command, control, and health management
- Payload control will be done by the C&DH system
- Single Fault Tolerant Avionics
- All electronics are ≥ 65 Krad avionics
- Cabling mass is estimated as 50% of the avionics hardware
- Avionics spares are cold spares to minimize power consumption
- NH S/C was used as the starting point for the avionics hardware design

All avionics components used in the design are based on commercially available components from British Aerospace (BAE) and SEAKR Engineering, Inc. (SEAKR). There are two independent avionics boxes to provide for single fault tolerance. Each avionics box contains a GN&C/C&DH RAD6000 processor, 256 MB GN&C solid-state memory card, SSR card, a Comm. interface card, and a payload interface card. The 1553 processor is used for communications between the GN&C processor and GN&C hardware, i.e., star trackers, IMUs, etc. The GN&C and C&DH computers communicate via the 1553 bus. This new REP avionics design is based on the NH S/C. With the exception of GN&C and C&DH, the processors for each IEM are combined into one, using either RAD6000 or RAD750.

Table 10 lists the components used in the COMPASS C&DH MEL design. These are the inputs from the subsystem lead. All growth allowances follow the AIAA MGA schedule in Section II.A, and do not contain the additional 8.8% carried at the system level.

TABLE 10.—AVIONICS MEL MASS DETAILS

Description	QTY	Unit Mass	CBE Mass	Growth	Growth	Total Mass
		(kg)	(kg)	(%)	(kg)	(kg)
REP Centaur Mission 6ASRG (10-11-2007)						
REP Spacecraft (Payload and Stage)			1071.00	11.68%	125.14	1196.14
REP Bus			1026.88	10.90%	111.91	1138.79
Command and Data Handling			33.30	34.26%	11.41	44.71
Command & Data Handling			33.30	34.26%	11.41	44.71
Flight Computer	2	8.00	16.00	25.00%	4.00	20.00
Command and Telemetry Computer	0	0.00	0.00	0.00%	0.00	0.00
Data Interface Unit	2	2.00	4.00	30.00%	1.20	5.20
Data Bus Operations Amplifier	0	0.00	0.00	0.00%	0.00	0.00
Operations Recorder	2	1.10	2.20	30.00%	0.66	2.86
Command and Control Harness (data)	1	11.10	11.10	50.00%	5.55	16.65
Instrumentation & Wiring			0.00	0.00%	0.00	0.00
Operational Instrumentation, sensors	0	0.00	0.00	0.00%	0.00	0.00
Data Cabling	0	0.00	0.00	0.00%	0.00	0.00

D. Avionics Trades

1. Avionics Concerns, Comments, Recommendations

- Processing power of the RAD6000 is assumed to be adequate for GN&C, C&DH, and science payload
- Storage requirements are driven by fly-by storage needs
- Only one SSR would be active at a time and thus susceptible to SEUs
- Total radiation dose is a concern with all deep space missions. This preliminary design has attempted to use only hardware which has already been proven in a deep space mission to assure the life of the electronics over the 12-yr mission.

VII. Electrical Power System

A. Power Requirements

Overall to the power design is to minimize power for non-propulsion during EP operation (minimize plutonium needed). This baseline power system design consisted of six ASRGs for the generation of power.

Six ASRG's (12 GPHS) are designed to provide 960 W to power the REP S/C at beginning of life (BOL). The system is designed to provide 900 W to the REP S/C at EOL (10-yr). There are negligible thermal interactions between the ASRG's. Figure 16 shows a typical ASRG with the main components called out in the graphic. The six are connected together with via a Shunt Regulator/Bus Protection (RBI) assembly. This RBI isolates the ASRG's from S/C bus and each other and follows load demands from S/C bus. There is an approximately 6% loss through the RBI and monitoring circuitry (94% of power flows through to loads) with 53 W used for fault detection/monitoring. Included in this system is a bus Capacitance of 3000 μf which provides some bus rigidity. Power cabling and harness systems design assumes a 1% line loss.

Specific performance details on each ASRG unit are as follows:

Power:	160 W at 28 ± 0.2 V BOL
	150 W at 28 ± 0.2 V EOL (10 yr)
	End of mission (EOM) (Deep Space (14 yr)) –126 We
Mass:	19.5 kg with mounting isolator plate
Envelope:	30.5 cm W, 46 cm H, 76 cm L (12 in. W, 18 in. H, 30 in. L)
Specific Power:	8 We/kg

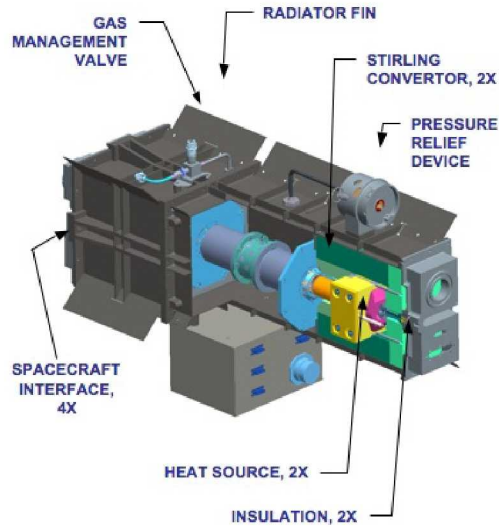

Figure 16.—ASRG CAD Model

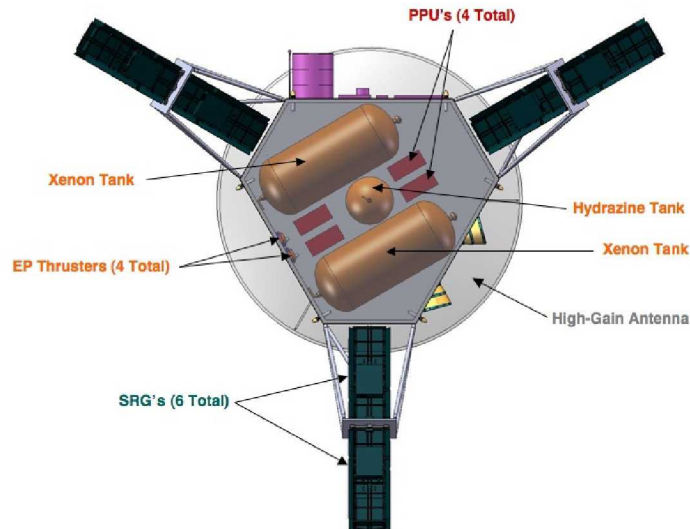

Figure 17.—Power and Propulsion System Deck

B. ASRG Design Attributes

- Two Stirling converters
 - Co-axially aligned for dynamic balance
 - One GPHS module per converter
- Integrated, single-fault tolerant controller
- Autonomous operation and fault isolation from S/C
- S/C disturbance torque requirement <35 N-m
 - Based on 1000 kg, 1-m cube S/C with 5- μ rad pointing accuracy and a safety factor of 5

Table 11 lists the items in the Power system MEL for the COMPASS REP S/C design. All growth allowances follow the AIAA MGA schedule in Section II.A.

Figure 17 shows the power and propulsion deck of the REP S/C. The ASRGs are mounted to the bus structure via trusses, at a 120° angle between each other on opposite sides of the main bus.

TABLE 11.—POWER SYSTEM MEL FOR REP BUS

Description	QTY	Unit Mass	CBE Mass	Growth	Growth	Total Mass
REP Centaur Mission 6ASRG (10-11-2007)		(kg)	(kg)	(%)	(kg)	(kg)
REP Spacecraft (Payload and Stage)			1071.00	11.68%	125.14	1196.14
REP Bus			1026.88	10.90%	111.91	1138.79
Electrical Power Subsystem			169.82	16.97%	28.82	198.64
Radioisotope Power System			116.82	10.00%	11.68	128.50
RPS Main System	6	19.47	116.82	10.00%	11.68	128.50
Misc#2	0	0.00	0.00	0.00%	0.00	0.00
Power Management & Distribution			26.75	15.00%	4.01	30.76
Power management/control electronics	0	0.00	0.00	0.00%	0.00	0.00
Power distribution/monitoring wiring harness	0	0.00	0.00	0.00%	0.00	0.00
DC Switchgear/Shunt Regulator	1	26.75	26.75	15.00%	4.01	30.76
Misc#2	0	0.00	0.00	0.00%	0.00	0.00
Power Cable and Harness Subsystem (C and HS)			26.25	50.00%	13.13	39.38
Spacecraft Bus Harness	1	5.25	5.25	50.00%	2.63	7.88
PMAD Harness	1	5.25	5.25	50.00%	2.63	7.88
Electric Propulsion Harnes	1	5.25	5.25	50.00%	2.63	7.88
RPS to Spacecraft Harness	1	5.25	5.25	50.00%	2.63	7.88
Power Cabling	1	5.25	5.25	50.00%	2.63	7.88

C. Power Trades

For the power system, two other options are as follows:

Option 1—(Not used since more power was needed than the 10/1 power ratio allowable on the dual-windings allowed. Significant advantages to the mission exist if the full ASRG power is available during non-thrusting periods.)

- Direct drive the Hall thrusters
- Through the use of dual wound alternator (providing 600 and 28 V, 100 Hz AC)
- 10/1 power ratio on dual alternators
- The 600 V AC converts to 400 V DC
- Power to Thrusters EOM 646 W
- Power to Payload EOM 76 W

Option 2—(Not used due to the heavy converter needed.)

- Each ASRG provides 28 V DC as designed
- DC/DC conversion to 400 V DC for hall thruster
- The current mass estimate of single 600 W DC/DC converter at 30 kg
- Eight ASRG provides (1120 W BOL, 1040 EOL) 750 W power into the thruster with excess 14 W EOL
- Loss of a single SRG would then provide ~650 W into Thruster

Table 12 lists the impact of trade in the number of ASRGs and total power available, as well as excess power to be radiated as mentioned in the Option 2 analysis up above.

TABLE 12.—TRADE ANALYSIS OF VARYING NUMBER OF SRGS

Number SRG	4	5	6	7	8
Power (EOL, 10 yr)	130	130	130	130	130
Total power EOL (W)	520	650	780	910	1040
Into thruster (w)	250	400	500	650	750
PPU, line loss	25	40	50	65	75
Housekeeping (cruise only)	155	155	155	155	155
Housekeeping margin (30%)	46.5	46.5	46.5	46.5	46.5
Excess	44	9	29	-7	14

VIII. Structures and Mechanisms

The REP S/C structure must contain necessary hardware for research instrumentation, avionics, communications, propulsion and power. It must be able to withstand applied loads from launch vehicle and provide minimum deflections, sufficient stiffness, and vibration damping. The goal of the design is to minimize weight of the components that make up the structure of the S/C bus, and must fit within confines of launch vehicle.

Because of the use of the Star 48 engine, the structure must be able to withstand an axial load of up to 6g maximum. The launch vehicle also imparts a maximum of 3.5g lateral acceleration. The structure must also accommodate a Conical Star 48 adapter. The hall thrusters must thrust through the center of mass (COM) and need to be canted. The structural design and S/C layout must accommodate a thruster gimbal angle.

The basic assumptions made in the design process of the S/C bus structure were:

- Material: Al alloy 2090-T3
- Space frame with tubular members
- Composite sandwich structure shelf assumed to be all Al using Al 2090-T3 face sheets and an Al honeycomb core with the trade name, Alcore Higrd.
- Welded and threaded fastener assembly

The basic structural design of the REP S/C shown in Figure 18 consists of:

- Tubular space frame in a hexagonal configuration
- Deck consists of a composite sandwich architecture with an Al 25 mm thick low density honeycomb core and 1.5 mm thick Al face sheets to mount hardware
- Thin sheets utilized as sheer panels and to enclose the structure
- Struts are used to support the paired SRGs externally. The SRGs are mounted to plates with vibration isolators.

All growth allowances follow the AIAA MGA schedule in Section II.A.

The Initial assumptions used in the design were: 2600 kg, 6g axial loading, 3.5g lateral loading (not concurrent with max axial loading), Al 2090-T3 and a 1.4 safety factor. The maximum stress in axial members was set at 58 MPa. Initial assumptions for lateral load capacity based on S/C heritage design.

Trade on the use of composite for the main bus compartment structure. The frame of the main bus is sized to accommodate volume and space requirements for antenna, SRGs, and instrumentation while fitting within confines of launch vehicle.

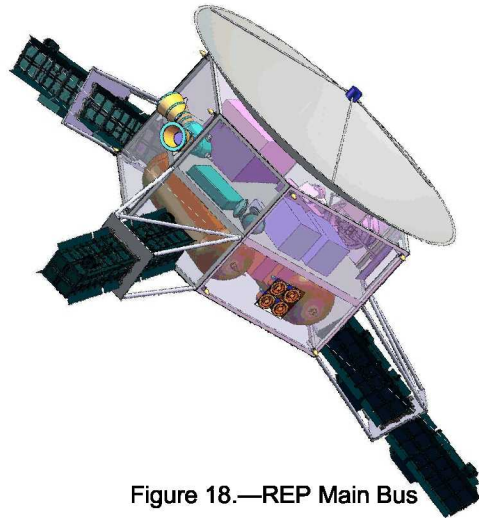

Figure 18.—REP Main Bus

TABLE 13.—REP SIX ASRG S/C STRUCTURES AND MECHANISMS BOTTOMS-UP MEL

Description	QTY	Unit Mass	CBE Mass	Growth	Growth	Total Mass
		(kg)	(kg)	(%)	(kg)	(kg)
REP Centaur Mission 6ASRG (10-11-2007)						
REP Spacecraft (Payload and Stage)			1071.00	11.68%	125.14	1196.14
REP Bus			1026.88	10.90%	111.91	1138.79
Structures and Mechanisms			97.99	20.00%	19.60	117.59
Structures			78.41	20.00%	15.68	94.09
Primary Structures			40.95	20.00%	8.19	49.15
Main Bus Structure	1	40.95	40.95	20.00%	8.19	49.15
Secondary Structures			37.45	20.00%	7.49	44.94
Balance Mass	0	0.00	0.00	0.00%	0.00	0.00
Tank Supports and Bracketry	1	18.18	18.18	20.00%	3.64	21.82
SRG Support structure	3	5.51	16.54	20.00%	3.31	19.85
SRG Vibration Isolation Hardware	3	0.91	2.73	20.00%	0.55	3.27
Mechanisms			19.58	20.00%	3.92	23.50
Adaptors and Separation			4.72	20.00%	0.94	5.67
Spacecraft Adapter	1	4.72	4.72	20.00%	0.94	5.67
Separation mechanism (pyros)	0	0.00	0.00	0.00%	0.00	0.00
Misc#1	0	0.00	0.00	0.00%	0.00	0.00
Installations			14.86	20.00%	2.97	17.83
Science Payload Installation	1	1.76	1.76	20.00%	0.35	2.12
C&DH Installation	1	1.33	1.33	20.00%	0.27	1.60
Communications and Tracking Installation	1	1.56	1.56	20.00%	0.31	1.87
GN&C Installation	1	0.74	0.74	20.00%	0.15	0.88
Electrical Power Installation	0	0.00	0.00	0.00%	0.00	0.00
Thermal Control Installation	1	3.03	3.03	20.00%	0.61	3.63
Electric Propulsion Installation	1	6.44	6.44	20.00%	1.29	7.73

Preliminary structural analysis and modeling was performed using the given launch loads and dimensions of the desired S/C bus. An additional installations mass was held for each subsystem in the mechanisms section of the structures system. These installations were modeled using 4% of the CBE dry mass of each of the subsystems. No growth margin was applied to that installation mass.

A more detailed structural analysis for loads and vibrations using a modeling tool, i.e., finite element analysis (FEA) would be beneficial in further modeling the structure with assurance of sustaining launch loads. Analysis is needed to look into using the current shelf face sheets, outer sheets, and/or support struts substituted with graphite/polymer composites for further weight savings but possibly at increased cost.

IX. Propulsion and Propellant Management

The REP Centaur mission is a relatively long life mission. The goal of each subsystem and the propulsion system is to minimize the overall mass of the REP bus in order to deliver the maximum amount of payload. The mission requirements that impact the choice of EP system components are as follows:

- Approximately 10 yr mission (~600 kg throughput)
- 500 to 1000 W total power
- Essentially constant power from ASRG power supply
- Preliminary optimum Isp ~2050 sec

The baseline system redundancy assumption was based on single string units. In other words, a propulsion system unit consists of a string of thruster, PPU, gimbal, and propellant management system. Spares or redundant units are assumed to consist of all of the above subsystems. It is important to note that the mission is already modeled with a 90% duty cycle. So, 10% of the time, the S/C is coasting along its trajectory. The baseline propulsion system design consists of the following items:

- One active 750 W long life Hall engine with two extra engines for lifetime issues and one cold spare
- Four PPUs: no cross-strap
- Two-axis range of motion: TBD
- 5.0% Xe navigation allowance, 3.6% Xe residuals
- PSI cylindrical COPV Xe tanks
- Off-the-shelf (OTS) hydrazine system with NH heritage

Hall thruster and PPU performance and masses were based on published or in-house calculations by the GRC RPP branch. Thruster performance over a range of specific impulse was examined as a series of custom designs, rather than a single thruster design throttled over a range of Isp. Thruster mass was assumed to be 50% greater than a commercial thruster (SPT-70), which operates at a similar power level. PPU performance and mass were based on a single module of a PPU unit under development and test at GRC.

The trades considered in designing the two major propulsion systems on the S/C (main and RCS) are as follows:

- ACS hydrazine
 - OTS blow-down similar to NH
 - Single tank with ~20 kg hydrazine

The possible main EP system options to be considered for this design are:

- New Advanced Technology Small Hall Thruster
 - Based on ongoing HiVHAC program at GRC
 - Optimized design to allow up to 2000 s Isp at powers below 1 kW
 - Allows long life needed for mission
- Derated HiVHAC

- Maximum Isp at 1 kW ~1570 s
- Performance inadequate for range of REP missions
- Commercial-off-the-shelf (COTS)
 - SPT-70/BPT-600
 - 600 W, ~ 1500 s
 - Limited life/throughput (35 to 50 kg)
- Low power (20 cm) Ion

The Advanced Hall thruster option was initially chosen both for its potential for Direct Drive operation (see power system discussion), and for its superior performance in terms of efficiency (or equivalently, thrust-to-power) at the low power levels characteristic of REP. The 20 cm ion thruster projected performance was inferior to that of the Hall below 1 kW and at 2000 sec or less Isp. The commercial Hall thrusters increased system mass and complexity through the increased number of propulsion strings (13 or more) needed to meet lifetime and redundancy requirements.

The possible EP thruster system options, once an EP thruster type has been chosen, to be considered are:

- Hall
 - Standard PPU
 - “Direct Drive” from Stirling Alternator

Because of limitations in the ASRG alternator design, the “Direct Drive” option was discarded and a standard PPU option was selected.

A. Propulsion and Propellant Management Design and MEL

1. Main EP System (Xe)

The main EP system is comprised of:

- Four extended life, High Isp Hall Thrusters (one operating)
 - Thruster performance
 - 30,000 hr life, 300 to 700 V
- Two cylindrical, COPV high pressure (2800 psi) Xe tanks
- Propellant distribution system: Single string PMS to each thruster from balanced tank feed
- Thermal details of prop system
 - Number of heaters on tanks, etc.
- Total propellant
 - 540 kg used
 - 8.6% Residual + Margin

Figure 20 is a schematic of the EP system and propellant management tankage, etc. The main EP subsystem is comprised of: four HIVAC Hall Thrusters—three operating, one spare, gimbals on each thruster for thrust vector control, two carbon-overwrapped (COPV) titanium-lined high-pressure cylindrical storage tanks for the Xe propellant (nominal), Xe distribution system based on newly developed pressure and flow control units and four PPU for delivering power to each ion thruster.

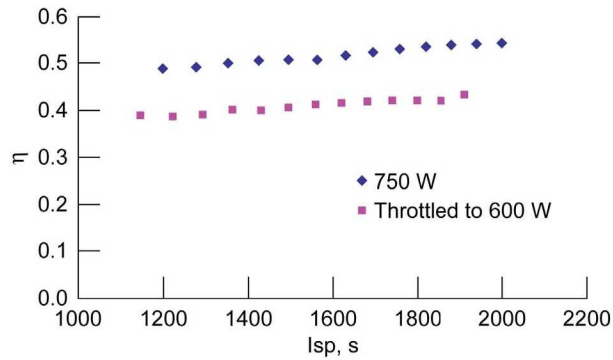

Figure 19.—Assumed Performance of Small Hall Thruster.

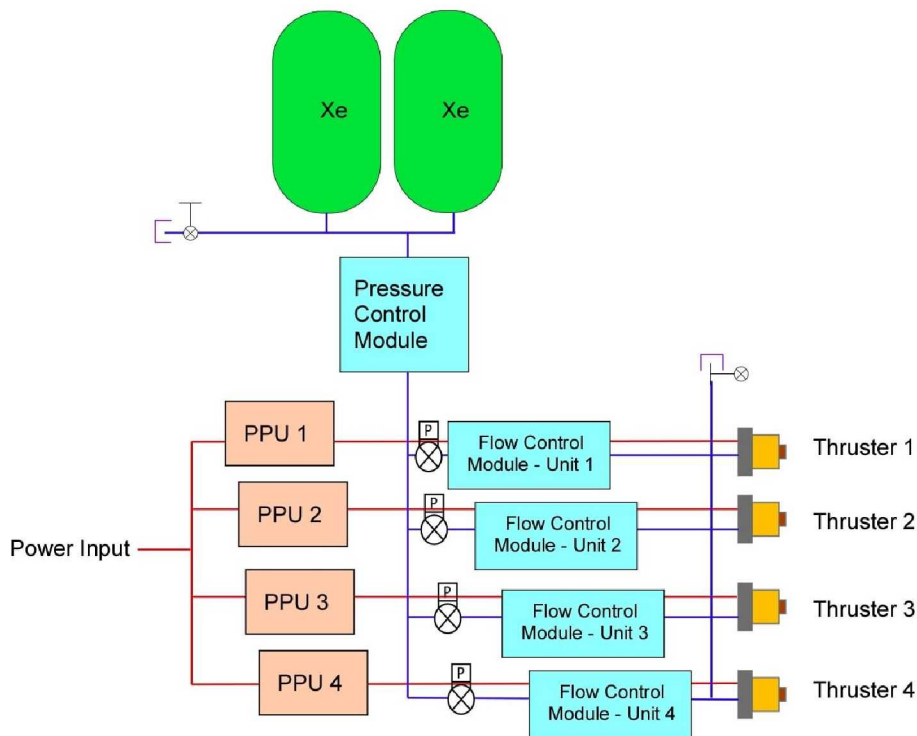

Figure 20.—EP System Schematic

2. Secondary RCS System (Hydrazine)

The attitude-reaction control propulsion subsystem is comprised of: eight 0.25 lbf monoprop thrusters placed around S/C body The Rocket Research MR-103H monomethyl hydrazine and nitrogen tetroxide (MMH/NTO) thrusters were used. Fuel is stored in an Al-Li metallic tank single spherical tank using a blow down pressurization with discrete He pressurization system (Cassini heritage). The propellant distribution system used a design similar to systems developed for the Constellation program, including fault tolerance configuration. Multiple tank and line heaters are included in the mass model to prevent propellants from freezing. Additionally, insulation is included for some elements. The Instrumentation included is a nominal suite of temperature and pressure sensors.

Table 15 lists the propellant used in this mission. Note, the margins and residuals are called out as separate line items in this mass listing, and no additional WGS is necessary on the propellants.

B. Propulsion and Propellant Management Recommendation

Future trades to reduce mass on the main propulsion system are as follows:

- Lower power ion thruster (8 cm)
- Re-optimize mission for lower Isp or higher power to capture HiVHAC or COTS regime

Further trades on the secondary propulsion system to reduce mass are

- Utilize primary propulsion for some maneuvering, and modeling the trade between attitude control using Wheels versus propulsion.

TABLE 14.—ELECTRIC AND CHEMICAL PROPULSION SYSTEM MELS

Description	QTY	Unit Mass	CBE Mass	Growth	Growth	Total Mass
		(kg)	(kg)	(%)	(kg)	(kg)
REP Centaur Mission 6ASRG (10-11-2007)						
REP Spacecraft (Payload and Stage)			1071.00	11.68%	125.14	1196.14
REP Bus			1026.88	10.90%	111.91	1138.79
Propulsion			107.99	26.56%	28.68	136.67
Primary EP System			9.00	12.00%	1.08	10.08
Primary EP Thrusters	4	2.25	9.00	12.00%	1.08	10.08
EPS Power Processing and Control	0	0.00	0.00	0.00%	0.00	0.00
EPS Structure			0.00	0.00%	0.00	0.00
EP Thruster Pod	0	0.00	0.00	0.00%	0.00	0.00
EP Thruster Boom	0	0.00	0.00	0.00%	0.00	0.00
Misc #1	0	0.00	0.00	0.00%	0.00	0.00
EPS Thermal Control Subsystem			0.00	0.00%	0.00	0.00
EPS Multi-Layer Insulation	0	0.00	0.00	0.00%	0.00	0.00
EPS Heaters and Sensors	0	0.00	0.00	0.00%	0.00	0.00
Misc #1	0	0.00	0.00	0.00%	0.00	0.00
Propellant Management			66.29	31.18%	20.67	86.96
Xe propellant tank(s)	2	27.39	54.77	30.00%	16.43	71.21
High Pressure Feed System	1	7.62	7.62	30.00%	2.29	9.90
Low Pressure Feed System	0	0.00	0.00	0.00%	0.00	0.00
Residual Xe Propellant (non deterministic)	0	0.00	0.00	0.00%	0.00	0.00
Temperature sensors	1	3.90	3.90	50.00%	1.95	5.85
Power Processing Unit (PPU)			16.00	12.00%	1.92	17.92
PPU Mass	4	4.00	16.00	12.00%	1.92	17.92
Cabling	0	0.00	0.00	0.00%	0.00	0.00
Reaction Control System			16.70	30.00%	5.01	21.71
RCS Tank Subassembly	1	2.79	2.79	30.00%	0.84	3.62
RCS Propellant Management Subassembly	1	9.45	9.45	30.00%	2.83	12.28
RCS Thruster Subassembly	2	2.23	4.46	30.00%	1.34	5.80

TABLE 15.—PROPELLANT MEL

Description	QTY	Unit Mass	CBE Mass	Growth	Growth	Total Mass
		(kg)	(kg)	(%)	(kg)	(kg)
REP Centaur Mission 6ASRG (10-11-2007)						
REP Spacecraft (Payload and Stage)			1071.00	11.68%	125.14	1196.14
REP Bus			1026.88	10.90%	111.91	1138.79
Propellant			517.57	0.00%	0.00	517.57
Primary EP Propellant			489.53	0.00%	0.00	489.53
Primary EP Propellant Used	1	450.76	450.76	0.00%	0.00	450.76
Primary EP Propellant Residuals (Unused)	1	16.23	16.23	0.00%	0.00	16.23
Primary EP Propellant Performance Margin (Ur	1	22.54	22.54	0.00%	0.00	22.54
RCS Propellant			27.94	0.00%	0.00	27.94
RCS Used	1	27.26	27.26	0.00%	0.00	27.26
RCS Residuals	1	0.68	0.68	0.00%	0.00	0.68
Pressurant	1	0.10	0.10	0.00%	0.00	0.10

X. Thermal Control

The thermal requirements for the REP Centaur were to provide a means of cooling the S/C during operation as well as provide heat to vital components and systems to maintain a minimum temperature throughout the mission. The goal of the thermal control system is to provide for the rejection of heat and maintain a safe operating environment for the electronics and other systems on the S/C.

The maximum heat load to be rejected by the thermal system was 125 W from the electronics, and the desired operating temperature for the electronics and propellant was 300 K. The ASRGs have dedicated built in thermal control systems and therefore were not part of the S/C thermal system. The system was modeled for Deep Space Operation. The radiator always sees deep space with a small (0.05) view factor to the Sun.

The assumptions utilized in the analysis and sizing of the thermal system were based on the operational environment. It was assumed that the worst case operational conditions would be in near Earth space. The following assumptions were utilized to size the thermal system.

- The view factors for the radiator to the Earth, lunar surface and ASRG radiators were assumed to be 0.1, 0.25 and 0.1 respectively.
- The maximum angle of the radiator to the Sun was 15°.
- The radiator temperature was 320 K.

The thermal system is used to remove excess heat from the electronics and other components of the system as well as provide heating to thermally sensitive components during periods of inactivity. Excess heat is collected from a series of Al cold plates located throughout the interior of the S/C. These cold plates have heat pipes integrated into them. The heat pipes transfer heat from the cold plates to the radiator, which radiates the excess heat to space. The portions of the heat pipes that extend from the S/C body and are integrated to the radiator are protected with a micro meteor shield. The radiator has exterior louvers on it to provide some control over its heat transfer capability.

TABLE 16.—THERMAL SYSTEM MEL

Description	QTY	Unit Mass	CBE Mass	Growth	Growth	Total Mass
		(kg)	(kg)	(%)	(kg)	(kg)
REP Centaur Mission 6ASRG (10-11-2007)						
REP Spacecraft (Payload and Stage)			1071.00	11.68%	125.14	1196.14
REP Bus			1026.88	10.90%	111.91	1138.79
Thermal Control (Non-Propellant)			42.81	15.00%	6.42	49.23
Active Thermal Control			16.90	15.00%	2.54	19.44
Heaters	15	1.00	15.00	15.00%	2.25	17.25
Thermal Control/Heaters Circuit	2	0.20	0.40	15.00%	0.06	0.46
Data Acquisition	1	1.00	1.00	15.00%	0.15	1.15
Thermocouples	50	0.01	0.50	15.00%	0.08	0.58
Misc#1	0	0.00	0.00	15.00%	0.00	0.00
Misc#2	0	0.00	0.00	15.00%	0.00	0.00
Passive Thermal Control			23.76	15.00%	3.56	27.33
Heat Sinks	4	3.46	13.85	15.00%	2.08	15.93
Heat Pipes	1	1.02	1.02	15.00%	0.15	1.17
Radiators	1	2.34	2.34	15.00%	0.35	2.69
MLI (Multi Layer Insulation)	1	3.77	3.77	15.00%	0.57	4.33
Temperature sensors	25	0.01	0.25	15.00%	0.04	0.29
Phase Change Devices	0	0.00	0.00	15.00%	0.00	0.00
Thermal Coatings/Paint	1	0.93	0.93	15.00%	0.14	1.07
Micro Meteor shielding	0	0.00	0.00	15.00%	0.00	0.00
Spacecraft RTG MLI	1	0.00	0.00	15.00%	0.00	0.00
Spacecraft Engine MLI	1	1.60	1.60	15.00%	0.24	1.84
Semi-Passive Thermal Control			2.15	15.00%	0.32	2.47
Louvers	1	1.35	1.35	15.00%	0.20	1.55
Thermal Switches	4	0.20	0.80	15.00%	0.12	0.92

The radiator was sized with approximately 50% margin in its heat rejection area. This added margin insures against unforeseen heat loads, degradation of the radiator and increased view factor toward the Sun or other thermally hot body not accounted for in the analysis. To provide internal heating for the electronics and propulsion systems a series of electric heaters are utilized. These heaters are controlled by an electronics controller, which reads a series of thermocouples through a data acquisition system. MLI is also utilized on the S/C, and propellant system to regulate and maintain the desired temperatures.

XI. Cost

The following items represent the assumptions in the costing analysis of the 6 ASRG REP S/C design. S/C costs reflect 50% confidence level. The ASRG is assumed to be flight ready by its own development project. The S/C fee is assumed at 10% and is not applied to science instruments (assumed to be furnished equipment). The NASA project office and technical oversight is based on 5% of all other costs. The costing for Phase A is based on 5% of S/C costs. The Launch services cost is based on guidance from 2003 New Frontiers AO. The 25% Reserves are not applied to Launch Services or RPS costs per 2003 New Frontiers AO. Table 17 shows the estimations for the REP S/C and science instruments life cycle costs (LCC).

Table 18 shows the costing per work breakdown structure (WBS) line items in the REP S/C MEL in FY08 \$M.

TABLE 17.—REP S/C AND SCIENCE INSTRUMENTS LCC

REP Thereus—New Frontiers Mission	
	FY08 \$M
NASA Project Office/Technical Oversight	31
Phase A	17
S/C with Science Instruments*	315
S/C Prime Contractor Fee (10%)	28
Launch Services	172
Mission Operations	94
Reserves (25%)	98
LCC	756

TABLE 18.—REP S/C COST PER MEL LINE ITEM IN FY08 \$M

WBS element	Element name	DDT&E total	Flight hardware	S/C total
01.1	Science Payload	22.7	12.3	35.0
01.1.1.a	LORRI	6.0	2.6	8.6
01.1.1.c	LIDAR	4.8	2.1	6.9
01.1.1.d	NGIMS			
01.1.2.a	WAC	1.2	0.5	1.7
01.1.2.b	NIMS	10.7	7.1	17.8
01.2.1	Attitude Determination and Control	9.0	7.6	16.6
01.2.1.a.a	Sun Sensors	1.4	3.0	4.5
01.2.1.a.b	Reaction Wheels	1.0	0.8	1.8
01.2.1.a.c	Star Trackers	0.9	1.8	2.7
01.2.1.a.d	IMU	5.7	1.9	7.6
01.2.2	C&DH	11.8	3.7	15.5
01.2.2.a.a	Flight Computer	2.6	3.0	5.5
01.2.2.a.c	Data Interface Unit	0.3	0.3	0.6
01.2.2.a.e	Operations Recorder	0.1	0.1	0.2
01.2.2.a.f	Command and Control Harness (data)	3.1	0.3	3.4
	Flight Software/Firmware	5.8		5.8
01.2.3	Communications and Tracking	8.9	4.6	13.5
01.2.3.a	X/Ka HGA			
01.2.3.a.a	Transmitter/Receiver	3.0	1.2	4.2

WBS element	Element name	DDT&E total	Flight hardware	S/C total
01.2.3.a.b	Power Amp	1.4	1.1	2.5
01.2.3.a.d	Antenna	2.3	1.6	3.9
01.2.3.a.h	Cabling	0.6	0.2	0.8
01.2.3.c.a	Coaxial Cable	1.7	0.4	2.1
01.2.4	EP Subsystem	3.8	125.4	129.2
01.2.4.a.a	RPS Main System		123.4	123.4
01.2.4.b	Power Management & Distribution	2.7	1.1	3.8
01.2.4.c	Power Cable and Harness Subsystem (C and HS)	1.1	0.9	2.0
01.2.5	Thermal Control (Non-Propellant)	3.6	1.0	4.7
01.2.5.a	Active Thermal Control	0.5	0.8	1.2
01.2.5.b	Passive & Semi-Passive Thermal Control	3.2	0.3	3.4
01.2.6	Propulsion	10.0	6.8	16.8
01.2.6.a.a	Primary EP Thrusters	0.8	1.2	2.0
01.2.6.b.a	Xe propellant tank(s)	1.4	0.7	2.1
01.2.6.b	Balance of propellant management system	2.0	0.7	2.7
01.2.6.c.a	PPU Mass	2.1	2.8	4.9
01.2.6.d	RCS			
01.2.6.d.a	RCS Tank Subassembly	0.1	0.0	0.2
01.2.6.d.b	RCS Propellant Management Subassembly	1.7	0.8	2.5
01.2.6.d.c	RCS Thruster Subassembly	1.9	0.5	2.4
01.2.8	Structures and Mechanisms	4.7	4.0	8.7
01.2.8.a	Structures	4.5	3.8	8.3
01.2.8.b.e	S/C Adapter	0.2	0.2	0.4
SUBTOTAL		74.6	165.4	240.1
SYSTEMS INTEGRATION		46.3	29.1	75.3
Integration, Assembly & Check Out		3.8	5.2	9.0
System Test Operations		4.4		4.4
Ground Support Equipment		7.9		7.9
System Engineering & Integration		14.8	16.4	31.1
Project Management		8.4	7.5	15.9
Launch Operations & Orbital Support		7.0		7.0
TOTAL PRIME COST		120.9	194.5	315.4

Conclusions and Further Work

In order to determine the key parameters for EP devices to perform these REP missions a design study was completed to design an REP S/C to orbit a Centaur in a New Frontiers cost cap. The design shows that an orbiter using several long lived (~200 kg Xe throughput), low power (~700 W) Hall thrusters teamed with six ASRGs (150 W each) can deliver 60 kg of science instruments to a Centaur in 10 yr within the New Frontiers cost cap. Optimal specific impulses for the Hall thrusters were found to be around 2000 sec with thruster efficiencies over 40%. Not only can the REP S/C enable orbiting a Centaur (when compared to an all chemical mission only capable of flybys) but the additional power from the REP system can be reused to enhance science and simplify communications.

Key to the feasibility for REP missions are long life, low power EP devices, low mass RPS and light S/C components. Performance of the REP mission could be improved by increasing ASRG power density and increasing thruster lifetime and efficiency. Further work is needed to trade ASRG mounting methods, optimizing structures (utilize more composites), and optimizing communications performance/mass based on the additional power available from the ASRG system.

Appendix—Acronyms and Abbreviations

ACS	Attitude Control System
AD&C	Attitude Determination and Control
Al	aluminum
AO	Announcement of Opportunity
APL	Applied Physics Laboratory
ASRG	Advanced Stirling Radioisotope Generators
BAE	British Aerospace
C&DH	Command and Data Handling
CBE	current best estimate
COM	center of mass
COMPASS	COLlaborative Modeling and Parametric Assessment of Space Systems
CONOPS	Concept of Operations
COPV	Composite Overwrapped Pressure Vessel
COTS	commercial-off-the-shelf
DSN	Deep Space Network
ELV	Expendable Launch Vehicle
EOL	end of life
EOM	end of mission
EP	Electric Propulsion
FEA	finite element analysis
GLIDE	GLobal Integrated Design Environment
GN&C	Guidance, Navigation & Control
GPHS	General Purpose Heat Source
GRC	NASA Glenn Research Center
He	helium
HGA	high gain antenna
HIVHAC	High Voltage Hall Accelerator
IEM	integrated electronics modules
IMU	Inertial Measurement Unit
IR	infrared
JPL	NASA Jet Propulsion Laboratory
KBO	Kuiper Belt Objects
LCC	life cycle costs
Li	lithium
LIDAR	Light Detection and Ranging
LORRI	Long Range Reconnaissance Imager
MEL	master equipment list
MGA	mass growth allowance
MLI	multilayer insulation
MMH/NTO	monomethyl hydrazine and nitrogen tetroxide
NAC	narrow angle camera
NH	New Horizon
NIGMS	Neutral Gas and Ion Mass Spectrometer
NIMS	Near Infrared Mapping Spectrometer
OTS	off the shelf
PEL	power equipment list
PMAD	Power Management and Distribution
PPU	Power Processing Units
RBI	Regulator/Bus Protection

RCS	Reaction Control System
REP	Radioisotope Electric Propulsion
RF	radio frequency
RPS	radioisotope power systems
RSEN	Reduced State Encounter Navigation
S/C	spacecraft
SEAKR	SEAKR Engineering, Inc.
SEP	solar electric power
SEU	Singe Event Upset
TBD	to be determined
THEMIS	Thermal Emission Imaging System
TWTA	Traveling Wave Tube Amplifier
WAC	wide angle camera
WBS	work breakdown structure
Xe	xenon

References

1. Oleson, S.R., Gefert, L., Patterson, M., Schreiber, J., Benson, S., McAdams, J., Ostdiek, P., "Outer Planet Exploration with Advanced Radioisotope Electric Propulsion," IEPC-2001-0179, International Electric Propulsion Conference, Pasadena, CA, Oct. 2001.
2. Oleson, S.R., Gefert, L., Schreiber, J., McAdams, J., "Sub-Kilowatt Radioisotope Electric Propulsion for Outer Solar System Exploration," Forum on Innovative Approaches to Outer Planetary Exploration 2001-2020, Lunar and Planetary Institute, Houston, TX, Feb. 2001.
3. Noble, R.J., "Radioisotope Electric Propulsion of Small Payloads for Regular Access to Deep Space," AIAA 93-1897, 29th Joint Propulsion Conference, Monterey, CA, 1993.
4. Noble, R.J., "Radioisotope Electric Propulsion for Small Robotic Space Probes," J. British Interplanetary Society, Vol. 49, pp. 455-468, 1996.
5. Noble, R. J., "Radioisotope Electric Propulsion of Sciencecraft to the Outer Solar System and Near-Interstellar Space," Nuclear News, Nov. 1999, pp 34-40.
6. Oleson, S.R., Benson, S., Gefert, L., Patterson, M., Schreiber, J., "Radioisotope Electric Propulsion for Fast Outer Planetary Orbiters", AIAA-2002-3967, 38th Joint Propulsion Conference, Indianapolis, IN, Jul. 2002.
7. NASA New Frontiers Program (<http://newfrontiers.larc.nasa.gov/>)
8. NASA Discovery Program (<http://discovery.nasa.gov/program.html>)
9. NASA Solar System Exploration Office (<http://solarsystem.nasa.gov/missions/future4.cfm>)
10. APL/JPL New Horizons Spacecraft website (<http://pluto.jhuapl.edu/>)
11. ANSI/AIAA R-020A-1999, Recommended Practice for Mass Properties Control for Satellites, Missiles, and Launch Vehicles
12. Jewitt, A. Delsanti The Solar System Beyond The Planets, to appear in the book Solar System Update, Springer-Praxis Ed., Horwood, Blondel and Mason, 2006)
13. List of Centaurs and Scattered-Disk Objects (<http://cfa-www.harvard.edu/iau/lists/Centaurs.html>)
14. NSTAR Engine References for Deep Space One (<http://nmp-techval-reports.jpl.nasa.gov/>)
15. John R. Brophy, Roy Y. Kakuda, James E. Polk, John R. Anderson, Michael G. Marcucci, David Brinza, Michael D. Henry, Kenneth K. Fujii, Kamesh R. Mantha, John F. Stocky, "Ion Propulsion System (NSTAR) DS1 Technology Validation Report."
16. Adcole Corporation (<http://www.adcole.com/en/>)
17. Valley Forge Bearcat 5 Nms reaction wheel (<http://www.vfct.com/aerospace/wheels/wheels2.html>)
18. NASA MESSENGER spacecraft webpage (<http://messenger.jhuapl.edu/>)

REPORT DOCUMENTATION PAGE			Form Approved OMB No. 0704-0188		
<p>The public reporting burden for this collection of information is estimated to average 1 hour per response, including the time for reviewing instructions, searching existing data sources, gathering and maintaining the data needed, and completing and reviewing the collection of information. Send comments regarding this burden estimate or any other aspect of this collection of information, including suggestions for reducing this burden, to Department of Defense, Washington Headquarters Services, Directorate for Information Operations and Reports (0704-0188), 1215 Jefferson Davis Highway, Suite 1204, Arlington, VA 22202-4302. Respondents should be aware that notwithstanding any other provision of law, no person shall be subject to any penalty for failing to comply with a collection of information if it does not display a currently valid OMB control number.</p> <p>PLEASE DO NOT RETURN YOUR FORM TO THE ABOVE ADDRESS.</p>					
1. REPORT DATE (DD-MM-YYYY) 01-07-2009		2. REPORT TYPE Technical Memorandum		3. DATES COVERED (From - To)	
4. TITLE AND SUBTITLE Radioisotope Electric Propulsion Centaur Orbiter Spacecraft Design Overview			5a. CONTRACT NUMBER		
			5b. GRANT NUMBER		
			5c. PROGRAM ELEMENT NUMBER		
6. AUTHOR(S) Oleson, Steve; McGuire, Melissa; Sarver-Verhey, Tim; Juergens, Jeff; Parkey, Tom; Dankanich, John; Fiehler, Doug; Gyekeyesi, John; Hemminger, Joseph; Gilland, Jim; Colozza, Tony; Packard, Tom; Nguyen, Thahn; Schmitz, Paul; Ostdiek, Paul; Gold, Rob; Lisse, Carey; Hibbits, Karl			5d. PROJECT NUMBER		
			5e. TASK NUMBER		
			5f. WORK UNIT NUMBER WBS 346620.02.01.02.03.01		
7. PERFORMING ORGANIZATION NAME(S) AND ADDRESS(ES) National Aeronautics and Space Administration John H. Glenn Research Center at Lewis Field Cleveland, Ohio 44135-3191			8. PERFORMING ORGANIZATION REPORT NUMBER E-16578-1		
9. SPONSORING/MONITORING AGENCY NAME(S) AND ADDRESS(ES) National Aeronautics and Space Administration Washington, DC 20546-0001			10. SPONSORING/MONITOR'S ACRONYM(S) NASA		
			11. SPONSORING/MONITORING REPORT NUMBER NASA/TM-2009-215488; AIAA-2008-5179		
12. DISTRIBUTION/AVAILABILITY STATEMENT Unclassified-Unlimited Subject Categories: 12, 13, 18, 20, 88, and 91 Available electronically at http://gltrs.grc.nasa.gov This publication is available from the NASA Center for AeroSpace Information, 443-757-5802					
13. SUPPLEMENTARY NOTES					
14. ABSTRACT Radioisotope electric propulsion (REP) has been shown in past studies to enable missions to outer-planetary bodies including the orbiting of Centaur asteroids. Key to the feasibility for REP missions are long life, low power electric propulsion (EP) devices, low mass radioisotope power systems (RPS) and light spacecraft (S/C) components. In order to determine what are the key parameters for EP devices to perform these REP missions a design study was completed to design an REP S/C to orbit a Centaur in a New Frontiers cost cap. The design shows that an orbiter using several long lived (~200 kg Xenon throughput), low power (~700 W) Hall thrusters teamed with six (150 W each) Advanced Stirling Radioisotope Generators (ASRG) can deliver 60 kg of science instruments to a Centaur in 10 yr within the New Frontiers cost cap. Optimal specific impulses for the Hall thrusters were found to be around 2000 sec with thruster efficiencies over 40 percent. Not only can the REP S/C enable orbiting a Centaur (when compared to an all chemical mission only capable of flybys) but the additional power from the REP system can be reused to enhance science and simplify communications.					
15. SUBJECT TERMS Electric propulsion; Hall thrusters; Asteroids; Design analysis; Radioisotope power system; Xenon; Stirling engine					
16. SECURITY CLASSIFICATION OF:			17. LIMITATION OF ABSTRACT	18. NUMBER OF PAGES	19a. NAME OF RESPONSIBLE PERSON
a. REPORT U	b. ABSTRACT U	c. THIS PAGE U			STI Help Desk (email: help@sti.nasa.gov)
			UU	37	19b. TELEPHONE NUMBER (include area code) 443-757-5802

