

Flight Validation of a Handling Qualities Metric for a Damaged Aircraft

NASA



*Integrated Resilient
Aircraft Control*

Objectives 13.5 X 4.5 inches	Analysis 13.5 X 9 inches	Results 13.5 X 19 inches
Technical Challenges 13.5 X 7 inches	Solution 13.5 X 16 inches	
Technical Approach 13.5 X 13.5 inches		Conclusions 13.5 X 6 inches

**These are survivable accidents
But....**

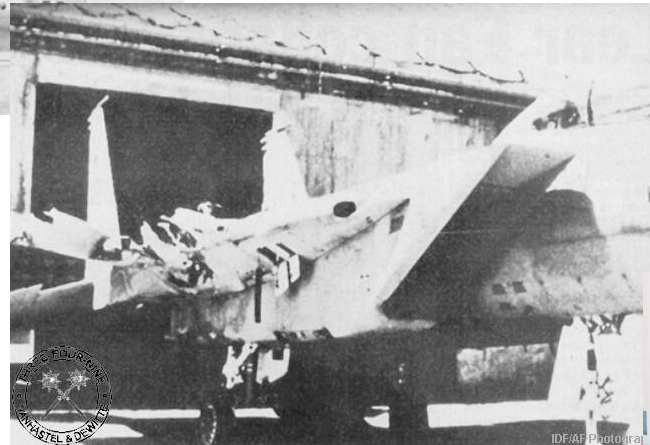

**Damage may cause a
large amount of cross-
coupling not usually
present in fixed wing
aircraft**

Objectives

- Develop an asymmetric handling qualities metric to predict cross coupling effects of a damaged aircraft
 - Initial use of U.S Army Aeronautical Design Specification ADS-33
 - Modification as required based on flight test results
- Simulation and Flight Validation of proposed metric
 - F-16 VISTA (March 2010)
 - F-18 Full Scale Test bed (Potential Early Experiment)
 - Flight Simulators (GTM, ACFS, F-18 HILS)
- Provide flight validated metric and tool box to control law designers

Cross-Coupling



- Control input causes undesired aircraft response in more than one axis:
 - Pitch due to roll stick input
 - Roll due to pitch stick input
- Common in helicopters

- Usually not an issue in fixed wing aircraft except:
 - Asymmetric Aircraft Designs
 - Damaged Aircraft



F-16 Variable Stability In-flight Simulator Test Aircraft (VISTA)



- **Problem Statement: Develop a handling qualities metric for an aircraft with failed control surfaces**
 - For good in-axis response (roll response due to lateral stick, pitch response due to longitudinal stick) the desire is to track the onboard reference model. Cooper Harper ratings are sufficient when evaluating in-axis response.
 - For good off-axis response (roll response due to longitudinal stick, pitch response due to lateral stick) it is desired that the response be minimized. Ideally, there should be no cross-coupling between pitch and roll. Currently there are no well established criteria to determine how much the cross-coupling needs to be reduced for acceptable handling qualities. Cross-coupling levels can be compared before and after adaption to show if an improvement was made; however better cross-coupling metrics are required to assess effectiveness of the adaptation and measure the severity of the failure.

U.S. Army Aerodynamic Design Standard ADS-33

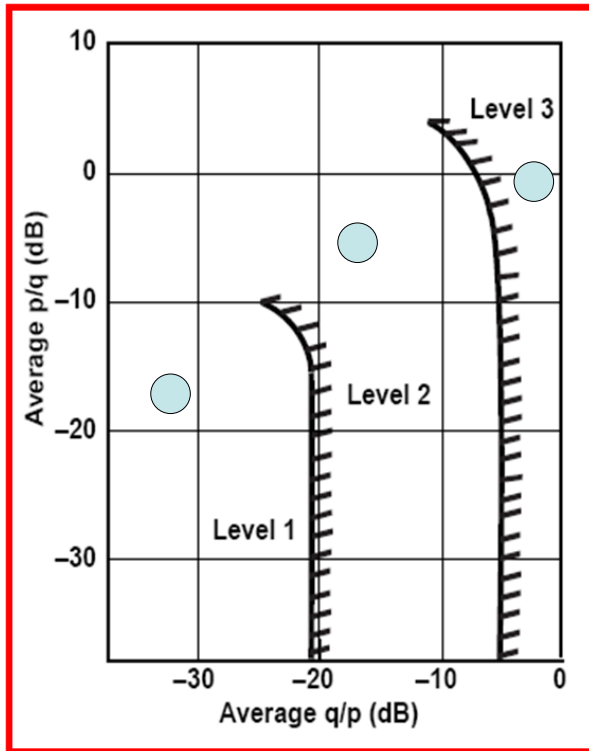

- Originally developed for the RAH-66 Comanche Helicopter
- Cross Coupling was a primary focus from the beginning
- Requires measurement of on-axis and off-axis response to control inputs
- Proposed by Hoh Aeronautics Inc (HAI) for use on damaged aircraft
- Flight test on F-16 VISTA will allow first evaluation on a fixed wing aircraft with induced cross-coupling



Cross-Coupling Control Law

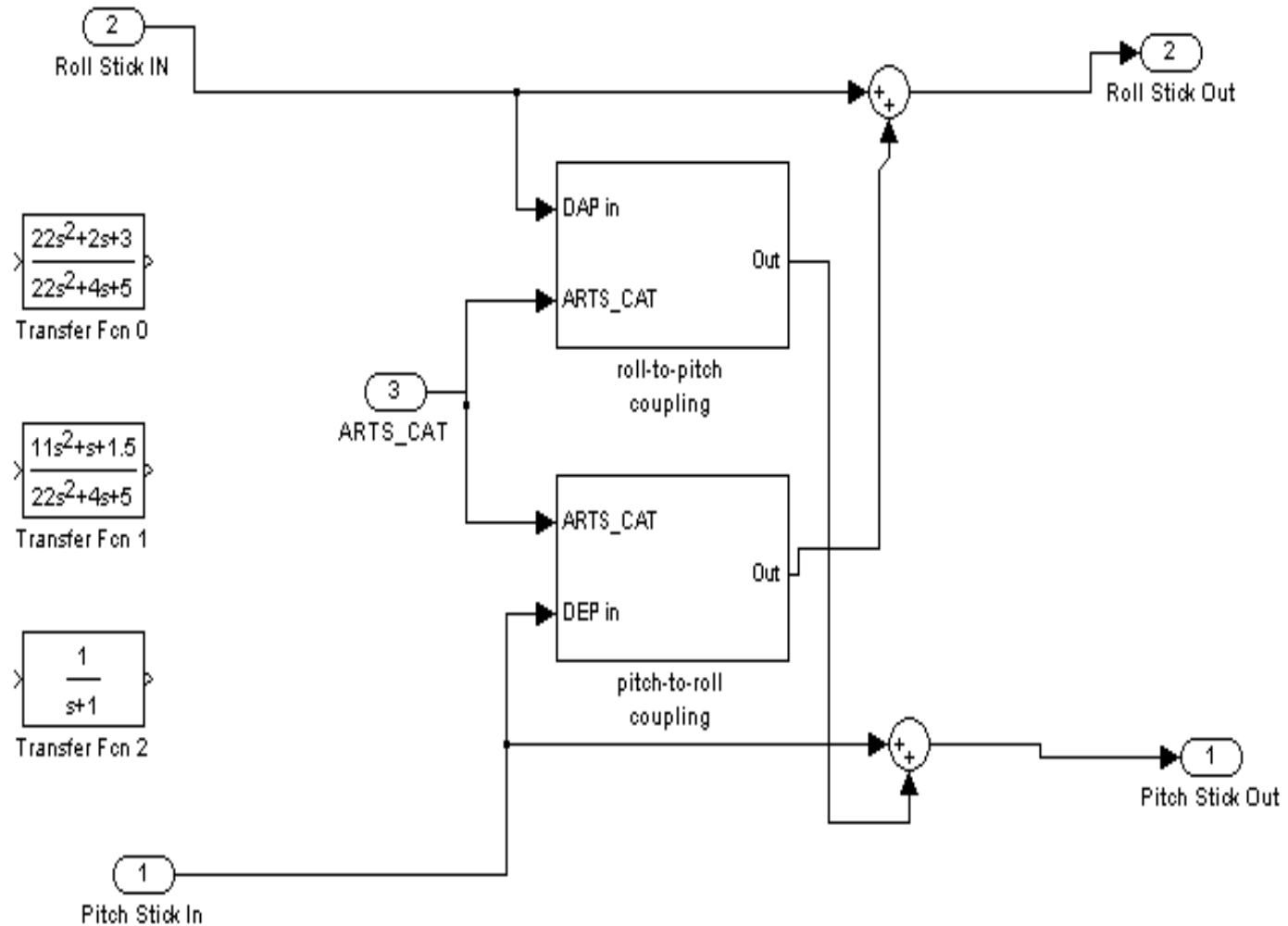

Method

- Simple modification to baseline aircraft control laws allows varying levels of cross-coupling (pitch due to roll, roll due to pitch) to be induced into the test aircraft
- The goal was to come up with modifications to allow varying predicted levels of handling qualities. A secondary goal was to design modifications to the control laws that were difficult for the pilot to compensate for.
- Pitch and roll frequency sweeps of the modified control system were performed. Data was evaluated using the cross-coupling handling qualities metric to determine predicted handling qualities.
- Predicted handling qualities will be compared with actual pilot ratings during the flight test phase.

Development

- **Initial cross-coupling control laws were developed in the NASA DFRC F-18 Simulation due to availability.**
- **Control laws developed in the F-18 simulation will be implemented in the USAF TPS F-16 VISTA simulation, evaluated, and modified as required.**
- **Final cross-coupling control law design will be loaded into the F-16 VISTA Computer and tested by Calspan Corporation in support of the flight test effort.**



Analysis

- Pitch and roll frequency sweeps will be performed for each cross-coupling control law stick input.
- Data will be analyzed using the cross-coupling handling qualities metric to determine predicted handling qualities
- Results from the metric will be compared with pilot ratings and comments from the test flights.

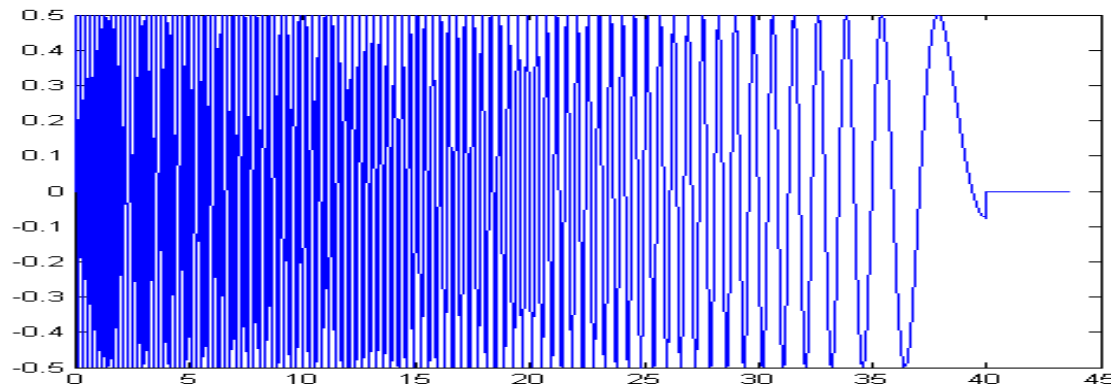
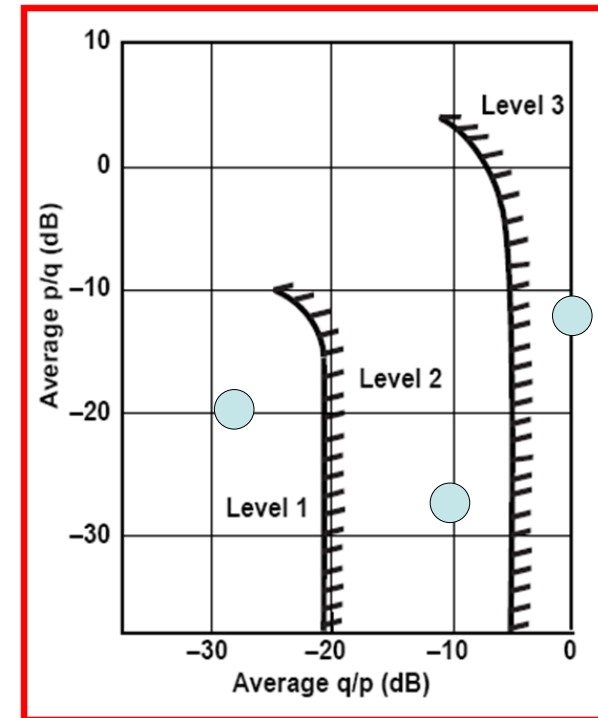

HAVE COUPLE

- Test Management Program (TMP) with USAF Test Pilot School
- Flown on F-16 Variable Stability In-flight Simulator Test Aircraft (VISTA)
- Aircraft control laws will be modified to introduce varying levels of cross coupling
- Subject pilots will be given a handling qualities task (formation flight, 3g tracking) and asked to provide Cooper-Harper ratings and comments
- Pilot ratings will be compared to those predicted by the HQ metric
- Over 10 TPS Student Pilots will participate. Possibility of participation by NASA Test Pilots.
- Student run to provide experience in running a flight test program
- Participation by NASA and HAI will ensure good research data
- Low program cost for number of flights (\$50K)
- Flight scheduled for March 2010



Future Work



- **Possible Future F-18 Full Scale Test Bed Experiment**
- **Experiment developed in NASA DFRC F-18 simulator as part of the HAVE COUPLE Effort**
- **Experiment will be auto-coded for ARTS testing and V&V**
- **Could serve as a simulated failure for evaluation of research control laws**
- **Would provide an additional flight validation of the metric for low level of effort**

Simulation Studies

- **Simplicity of cross-coupling control law allows easy implementation in various flight simulations.**
- **Simulator evaluation would provide a wider range of aircraft that could be tested as well as a larger number of subject pilots**
- **Possible candidates include:**
 - **NASA Ames Advanced Concepts Flight Simulator (ACFS)**
 - **NASA Langley 757 and GTM Simulations**
 - **USAF TPS Handling Qualities Simulation**



Conclusions

- Cross-coupling, is usually not a problem for fixed wing aircraft except for asymmetrical and damaged aircraft.
- Currently no good metric exists to determine amount of cross-coupling in a damaged aircraft. ADS-33, developed for helicopters, may provide a useful metric for fixed wing aircraft.
- The HAVE COUPLE project, to be flown on F-16 VISTA, will provide the first opportunity to flight validate this handling qualities metric.
- Future validation in flight simulators and other test aircraft such as F-18, will allow greater confidence in this tool.
- The final goal is a metric that can be used by control law designers to determine the magnitude of cross-coupling in an aircraft and the effectiveness of a control in reducing it.