

The performance of the basic scanning terahertz heterodyne imaging system is limited by a number of factors, the most prominent one being frequency instability of the lasers. The figure depicts a more complex prototype system that incorporates an IF stabilization subsystem that increases the achievable frequency stability and dynamic range. This system utilizes two mixers denoted the reference and signal mixers, and the signal from each laser is split into two beams denoted the reference and signal beams. One of the lasers is slightly detuned so that their frequencies differ by an IF between 1 and 3 MHz. The IF outputs of the two mixers are equal in frequency; however, they differ in amplitude and phase because of the loss and phase shift suffered by the signal beam that passes through the

specimen and impinges on the signal mixer.

The IF output of the signal mixer becomes one of two inputs to a third mixer that is part of the IF stabilization subsystem. In a fourth mixer that is also part of the IF stabilization subsystem, the IF output of the reference mixer is mixed with a stable 14.6-MHz oscillator signal, and the resulting signal becomes the other input to the third mixer. The output of the third mixer and thus the output of the IF stabilization subsystem is a signal that has a stable frequency of 14.6 MHz but exhibits variations in amplitude and phase according to the loss and phase shift of the signal beam passing through the specimen. An improved system with an IF of 24 GHz has now been completed with a dynamic range of 100 dB

(Figure 2), 100 pixels/second, and penetration of 25 mm.

This work was done by Peter Siegel and Robert Dengler of Caltech for NASA's Jet Propulsion Laboratory. Further information is contained in a TSP (see page 1).

In accordance with Public Law 96-517, the contractor has elected to retain title to this invention. Inquiries concerning rights for its commercial use should be addressed to:

*Innovative Technology Assets Management
JPL*

Mail Stop 202-233

4800 Oak Grove Drive

Pasadena, CA 91109-8099

(818) 354-2240

E-mail: iaoffice@jpl.nasa.gov

Refer to NPO-40474, volume and number of this NASA Tech Briefs issue, and the page number.



Master Clock and Time-Signal-Distribution System

This system has a modular, flexible architecture and is user-friendly.

NASA's Jet Propulsion Laboratory, Pasadena, California

A timing system comprising an electronic master clock and a subsystem for distributing time signals from the master clock to end users is undergoing development to satisfy anticipated timing requirements of NASA's Deep Space Network (DSN) for the next 20 to 30 years. The developmental system is intended to supplant the aging DSN frequency and timing subsystem (FTS), which, while historically reliable, is complex, has limited distribution capacity and has become increasingly difficult to operate and sustain. This system has a modular, flexible, expandable architecture that is easier to operate and maintain than the present FTS. Replicas of this system could be useful in laboratories and other facilities in which there are stringent timing requirements that could include requirements to distribute precise time signals over long distances.

The system [to be installed in each Deep Space Communications Complex (DSCC) in the original DSN application] includes three major hardware assemblies interconnected by an infrastructure of fiber-optic cables (see figure). One major hardware assembly is the master clock assembly (MCA), wherein time signals are generated in synchronism with a 100-MHz reference signal from an atomic frequency standard, denoted the "online" standard.

The MCA is set to Universal Coordinated Time and generates a system time code (STC) for distribution of time-of-day and timing-rate information to the entire DSCC. The STC is sent, via fiber-optic cables, to a distribution assembly (DA). The DA contains 10 distribution modules (DMs), each of which reconstitutes the STC and transmits the signal, either to a second-stage DA for additional fan-out or to a time-code translator (TCT), which serves as a timing reference interface for an end user. The TCT compensates for transmission delays from the MCA and can generate a variety of time codes and pulse rates as required.

The MCA, the DAs, and the TCTs reside in standardized chassis that are hot-swappable and include dual redundant power supplies. The MCA and DA chassis are identical; the TCT chassis are different and match those of the TCTs of the FTS. The back of each TCT can accommodate four plug-in modules to provide different time-code and pulse rate outputs.

For high reliability, the system includes, from the perspective of each end user, two flywheel oscillators. One flywheel oscillator is part of the MCA. The main purpose of this flywheel oscillator is to maintain MCA time in the event of loss or interruption of the reference sig-

nal from the online standard. While the timing performance slowly deteriorates in the absence of the reference signal, the complex remains operational until the reference signal can be restored. A second flywheel oscillator is part of each TCT. This oscillator enables the TCT to continue to generate time-code and pulse-rate outputs in the event of interruption of time signals anywhere in the distribution infrastructure. The TCT flywheel oscillator is allowed to run for a holdover interval up to 12 hours — more than enough time for diagnosis and repair.

This system is designed to be user-friendly, requiring minimal expertise and minimal human intervention for clock setup and diagnosis of faults. In the original DSN application, operators already have an overabundance of status and fault information to analyze. In this system, the only status or fault information provided to operators is that which facilitates isolation of a failure to the module level. Local alarm indications in a TCT, visible as lighted front-panel light-emitting diodes (LEDs), are summed together and communicated back to the applicable DA by simply blanking one pulse of a 1-pulse-per-second monitor return signal. A missing-pulse detector circuit in each DM in each DA responds to a

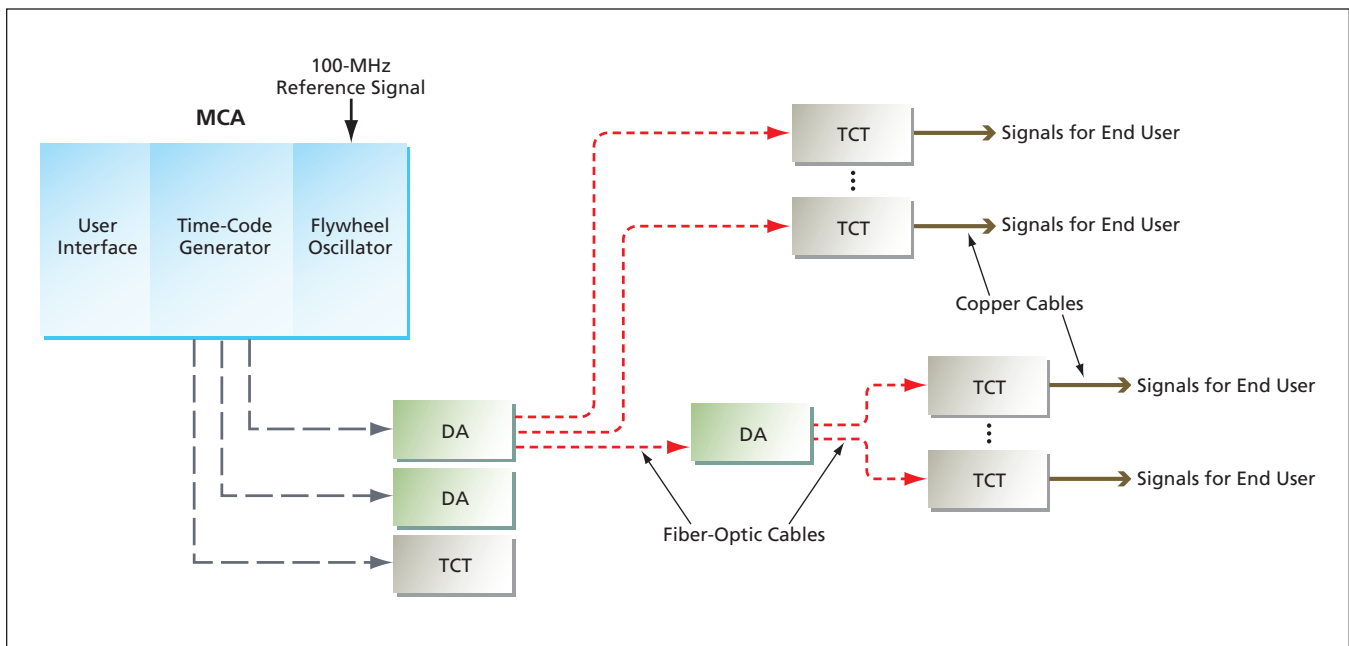

The **Timing System** consists of hardware modules interconnected by fiber-optic cables. This block diagram is a highly simplified representation: The real system has a more complex fan-out, with more modules, cables, and end users.

blanked pulse by turning on an LED in the DM. Each DA chassis contains one alarm representing the summed alarms of all 10 of its DMs. This alarm is passed further back up the hierarchy or collected by a status summary monitor

computer visible to operators. With modularity and simple “go/no-go” monitoring and alarm information, operators can maintain operations with little understanding of the nuances of the precise timing system.

This work was done by Robert Tjoelker, Malcolm Calhoun, Paul Kuhnle, Richard Sydnor, and John Lauf of Caltech for NASA's Jet Propulsion Laboratory. Further information is contained in a TSP (see page 1). NPO-40851

Synchronous Phase-Resolving Flash Range Imaging

Complete range images are generated, without scanning, at a video frame rate.

NASA's Jet Propulsion Laboratory, Pasadena, California

The figure is a simplified diagram of an apparatus, now undergoing development, for range imaging based on measurement of the round-trip phase delay of a pulsed laser beam. Variants of this apparatus could be used to provide range information needed for navigation of autonomous robotic ground vehicles and robotic aircraft, and for navigation and aiming in numerous military applications.

The apparatus would operate in a staring mode. A pulsed laser would illuminate a target. Laser light reflected from the target would be imaged on a very-large-scale integrated (VLSI)-circuit image detector, each pixel of which would contain a photodetector and a phase-measuring circuit. The round-trip travel time for the reflected laser light incident on each pixel, and thus the distance to the portion of the target imaged in that pixel, would be measured in terms of the phase difference between

(1) the photodetector output pulse and (2) a local-oscillator signal that would have a frequency between 10 and 20 MHz and that would be synchronized with the laser-pulse-triggering signal.

This apparatus offers several advantages over prior laser range imagers (essentially, scanning lidar systems based on explicit measurement of round-trip pulse travel times). A typical scanning lidar system consumes tens of watts of power, must be large because of the need for complex optics and mechanical scanning, and must include a clock running at a frequency of the order of a gigahertz. Moreover, because of the need for mechanical scanning to build up a range image, it is not possible to achieve an update rate (frame rate) sufficient for most applications.

In contrast, because of its staring mode of operation, the developmental apparatus could utilize simpler optics and would contain no moving parts. Be-

cause of the elimination of mechanical scanning and the use of VLSI circuitry, the power demand of this apparatus would be only about 100 mW. Moreover, because a complete range image could be constructed for each successive laser pulse, it would be possible to achieve an update rate, greater than the standard video frame rate of 30 Hz, that would be sufficient for most robotic applications. It has been estimated that the apparatus could provide a range resolution of 1 cm. The maximum range of the apparatus would depend on the details of the design and the specific application: for example, on the basis of the minimum detectable photocurrent density, the maximum range would be about 1 km for a 15°-wide field of view or about 100 m for a 60°-wide field of view.

A prototype of the phase-measuring VLSI image detector has been demonstrated. In each pixel, the output of the photodiode and the local-oscillator sig-