

smaller (and, hence, less massive) than is a tank needed for transporting the same mass of gas according to the conventional method.

Upon arrival at the destination, the transport tank would be connected to the tank to be recharged via a transfer line that would include a second low-power electric heater. The relief valve would be disconnected and the line to the gas system opened, causing the pressure in the transport tank to rise to the system pressure. The transport

tank and transfer-line electric heaters would be turned on, causing the contents of the tank to expand under high pressure and flow out through the transfer line. The transfer-line heater would further warm the flowing fluid to room temperature. The relative power levels of the electric heaters would be set to ensure that the fluid expelled from the tank by the tank heater could be delivered as room-temperature gas to the tank to be recharged. The transfer of gas would

be complete once the remaining gas inside the transport tank had been heated to room temperature. By virtue of the difference between densities, at completion, the majority of the mass of the transported cryogenic fluid would have been converted to gas and transferred to the recharged tank.

*This work was done by Eugene K. Ungar and Warren P. Ruumelle of Johnson Space Center and William Carl Bohannon of The Boeing Co. Further information is contained in a TSP (see page 1). MSC-24343-1*

## Water-Vapor Raman Lidar System Reaches Higher Altitude

Signal-to-noise ratios are increased over those of prior such systems.

NASA's Jet Propulsion Laboratory, Pasadena, California

A Raman lidar system for measuring the vertical distribution of water vapor in the atmosphere is located at the Table Mountain Facility (TMF) in California. Raman lidar systems for obtaining vertical water-vapor profiles in the troposphere have been in use for some time. The TMF system incorporates a number of improvements over prior such systems that enable extension of the altitude range of measurements through the tropopause into the lower stratosphere.

One major obstacle to extension of the altitude range is the fact that the mixing ratio of water vapor in the tropopause and the lower stratosphere is so low that Raman lidar measurements in this region are limited by noise. Therefore, the design of the TMF system incorporates several features intended to maximize the signal-to-noise ratio. These features include (1) the use of 355-nm-wavelength laser pulses having an energy (0.9 J per pulse) that is high relative to the laser-pulse energy levels of prior such systems, (2) a telescope having a large aperture (91 cm in diameter) and a narrow field of view (angular width  $\approx 0.6$  mrad), and (3) narrow-band-pass (wavelength bandwidth 0.6 nm) filters for the water-vapor Raman spectral channels. In addition to the large-aperture telescope, three telescopes having apertures 7.5 cm in diameter are used to collect returns from low altitudes.

The receiver portion of this lidar system has a total of eight channels (see figure). These include three channels for the water-vapor Raman returns at a wavelength of 407 nm, three channels for the nitrogen Raman returns at a wavelength of 387 nm, and two channels for elastic-

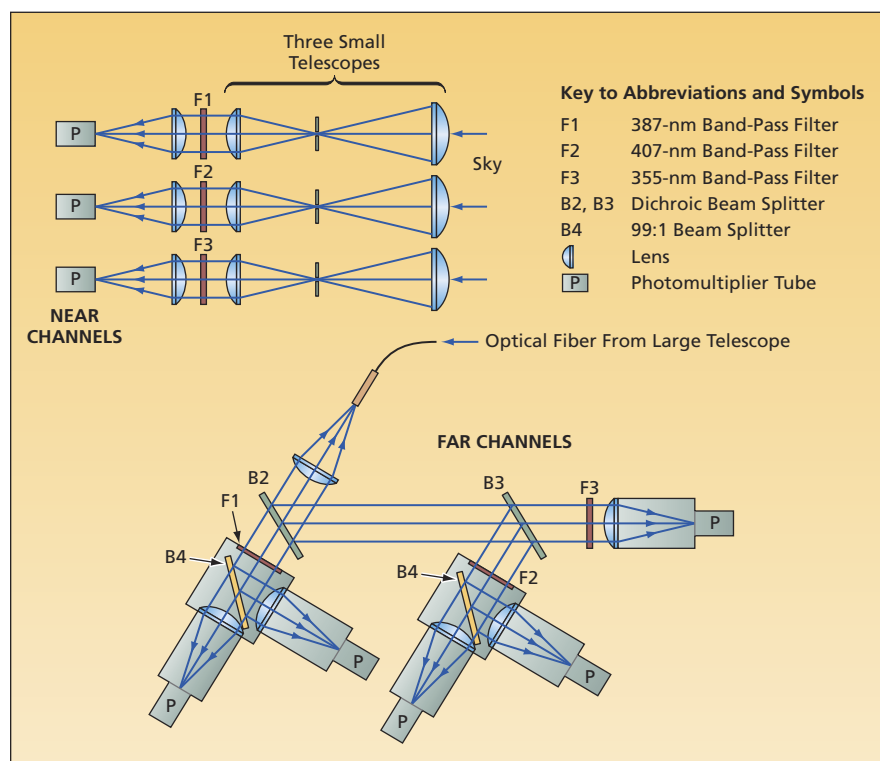

These Partly Schematic Optical Layouts show the paths followed by Raman and elastically scattered returns collected by a large telescope and three smaller telescopes.

scattering returns at the laser wavelength of 355 nm. Three of the channels (a 387-, a 407-, and a 355-nm channel), denoted the near channels, process the Raman and elastic returns collected by the three smaller telescopes. The remaining five channels, denoted the far channels, process the Raman and elastic returns collected by the large telescope. The elastic-scattering returns are used primarily for deriving temperature profiles. The light in each channel is meas-

ured by use of a photomultiplier tube, the output of which is fed to a commercially available optical-transient recorder operating as a photon-counting multi-channel scaler. The altitude interval of each bin of the scaler is 7.5 m, but typically, bins are summed together in groups of 10, yielding discretization of altitude in increments of 75 m.

The light collected by the large telescope is focused into an optical fiber, which delivers the light to a lens that

collimates the light into a series of beam splitters. Among the beam splitters are a 99:1 beam splitter for each of the two Raman wavelength bands. In addition to extending the dynamic range of the photon counting system, this arrangement enables better corrections for pulse pile-up saturation effects than

could otherwise be made. The arrangement is such as to make the 387- and 407-mm Raman signals in the large-telescope 1-percent splitter outputs approximately equal in magnitude to the corresponding signals from the smaller telescopes; this makes it possible to use the signals from the small telescopes to

correct for effects of overlap of photon pulses in signals from the large telescope collected from low altitudes.

*This work was done by Thierry Leblanc and I. Stewart McDermid of Caltech for NASA's Jet Propulsion Laboratory. Further information is contained in a TSP (see page 1). NPO-45007*

## Compact Ku-Band T/R Module for High-Resolution Radar Imaging of Cold Land Processes

This module can be used in phased-array antennas for radar or communications.

NASA's Jet Propulsion Laboratory, Pasadena, California

Global measurement of terrestrial snow cover is critical to two of the NASA Earth Science focus areas: (1) climate variability and change and (2) water and energy cycle. For radar backscatter measurements, Ku-band frequencies, scattered mainly within the volume of the snowpack, are most suitable for the SWE (snow-water equivalent) measurements. To isolate the complex effects of different snowpack (density and snow-grain size), and underlying soil properties and to distinctly determine SWE, the space-based synthetic aperture radar (SAR) system will require a dual-frequency (13.4 and 17.2 GHz) and dual-polarization approach.

A transmit/receive (T/R) module was developed operating at Ku-band frequencies to enable the use of active electronic scanning phased-array antenna for wide-swath, high-resolution SAR imaging of terrestrial snow cover. The T/R module has an integrated calibrator, which compensates for all environmental- and time-related changes, and results in very stable power and amplitude characteristics. The module was designed to operate over the full frequency range of 13 to 18 GHz, although only the two frequencies, 13.4 GHz and 17.2 GHz, will be used in this SAR radar application. Each channel of the transmit module produces >4 W (35 dbm) over the operating bandwidth of 20 MHz. The stability requirements of <0.1 dB receive gain accuracy and <0.1 dB transmit power accuracy over a wide temperature range are achieved using a self-correction scheme, which does real-time amplitude calibration so that the module characteristics are continually corrected. All the calibration circuits are within the T/R module.

The timing and calibration sequence is stored in a control FPGA (field-programmable gate array) while an internal 128Kx8bit high-speed RAM (random access memory) stores all the calibration values. The module was designed using advanced components and packaging techniques to achieve integration of the electronics in a 2x6.5x1-in. (5x17x2.5-

cm) package. The module size allows 4 T/R modules to feed the 16x16-element subarray on an antenna panel. The T/R module contains four transmit channels and eight receive channels (horizontal and vertical polarizations). Each channel contains GaAs MMIC (monolithic microwave integrated circuit) amplifiers, a 5-bit phase shifter, and a programmable

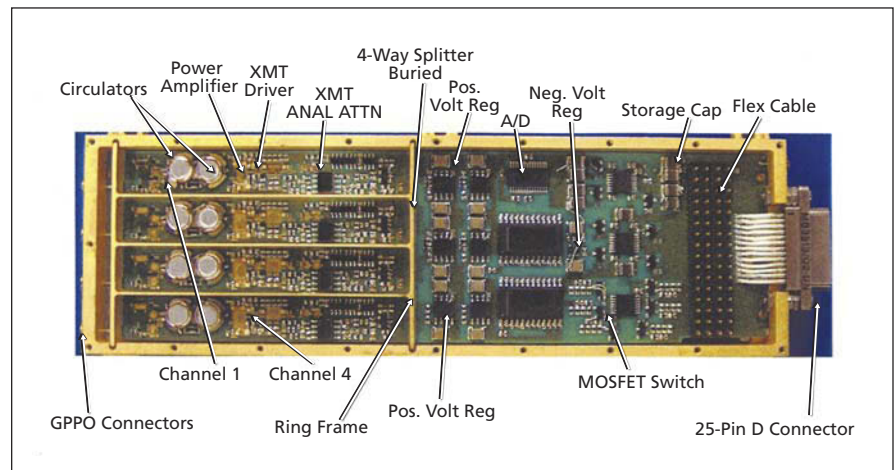

Figure 1 Transmission Side of the T/R Module showing the components.

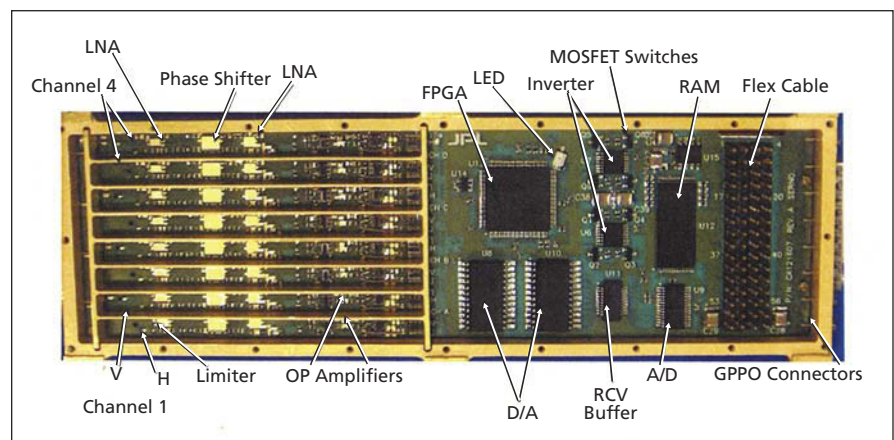

Figure 2. Receiving Side of the T/R Module showing the components.