

rial of interest is much smaller than in ordinary twist drilling, ordinary hammering, or ordinary steady pushing.

Examples of properties that could be measured by use of an instrumented tool bit include electrical conductivity, permittivity, magnetic field, magnetic permeability, temperature, and any other properties that can be measured by fiber-optic sensors. The problem of instrumenting a probe of this type is simplified, relative to the problem of attaching electrodes in a rotating drill bit, in two ways:

(1) Unlike a rotating drill bit, a bit of this type does not have flutes, which would compound the problem of ensuring contact between sensors and the side wall of a hole; and (2) there is no need for slip rings for electrical contact between sensor electronic circuitry and external circuitry because, unlike a rotating drill, a tool bit of this type is not rotated continuously during operation.

One design for a tool bit of the present type is a segmented bit with a segmented, hinged support structure (see figure). The bit and its ultrasonic/sonic actuator are supported by a slider/guid-

ing fixture, and its displacement and preload are controlled by a motor. For deployment from the folded configuration, a spring-loaded mechanism rotates the lower segment about the hinges, causing the lower segment to become axially aligned with the upper segment. A latching mechanism then locks the segments of the bit and the corresponding segments of the slider/guiding fixture. Then the entire resulting assembly is maneuvered into position for drilling into the ground.

Another design provides for a bit comprising multiple tubular segments with an inner alignment string, similar to a foldable tent pole comprising multiple tubular segments with an inner elastic cable connecting the two ends. At the beginning of deployment, all segments except the first (lowermost) one remain folded, and the ultrasonic/sonic actuator is clamped to the top of the lowermost segment and used to drive this segment into the ground. When the first segment has penetrated to a specified depth, the second segment is connected to the upper end of the first segment to

form a longer rigid tubular bit and the actuator is moved to the upper end of the second segment. The process as described thus far is repeated, adding segments until the desired depth of penetration has been attained.

Yet other designs provide for bits in the form of bistable circular- or rectangular-cross-section tubes that can be stowed compactly like rolls of flat tape and become rigidified upon extension to full length, in a manner partly similar to that of a common steel tape measure. Albeit not marketed for use in tool bits, a bistable reeled composite product that transforms itself from a flat coil to a rigid tube of circular cross section when unrolled, is commercially available under the trade name RolaTube™ and serves as a model for the further development of tool bits of this subtype.

This work was done by Yoseph Bar-Cohen, Mircea Badescu, Theodore Iskenderian, Stewart Sherrit, Xiaoqi Bao, and Randel Lindemann of Caltech for NASA's Jet Propulsion Laboratory. Further information is contained in a TSP (see page 1). NPO-45289

Compact Rare Earth Emitter Hollow Cathode

This rare earth insert for ion and Hall thrusters has longer life and resistance to poisoning.

NASA's Jet Propulsion Laboratory, Pasadena, California

A compact, high-current, hollow cathode utilizing a lanthanum hexaboride (LaB_6) thermionic electron emitter has been developed for use with high-power Hall thrusters and ion thrusters. LaB_6 cathodes are being investigated due to their long life, high current capabilities, and less stringent xenon purity and handling requirements compared to conventional barium oxide (BaO) dispenser cathodes. The new cathode features a much smaller diameter than previously developed versions that permit it to be mounted on axis of a Hall thruster ("internally mounted"), as opposed to the conventional side-mount position external to the outer magnetic circuit ("externally mounted"). The cathode has also been reconfigured to be capable of surviving vibrational loads during launch and is designed to solve the significant heater and materials compatibility problems associated with the use of this emitter material. This has been accomplished in a compact design with the capability of high-emission current (10 to 60 A). The compact, high-current design has a

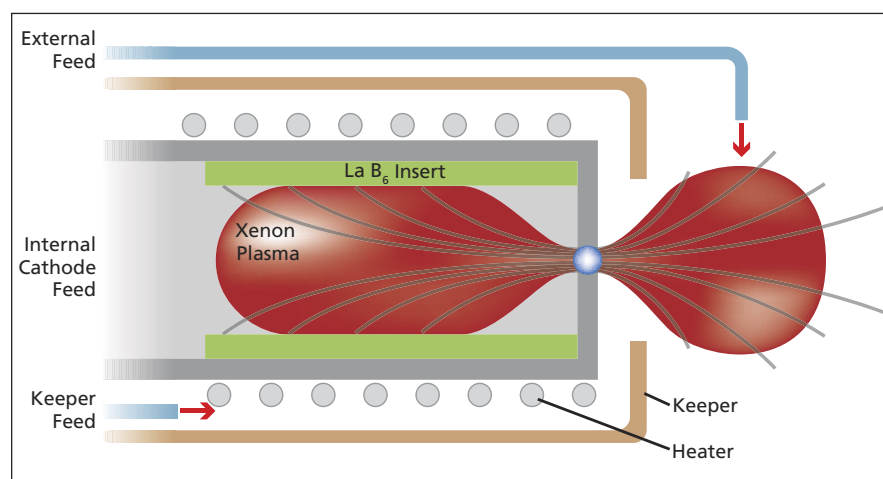

A Schematic of the Hollow Cathode with external gas feeds either directly into the cathode plume or into the cathode keeper gap, both of which feed gas into the plasma exterior to the insert region.

keeper diameter that allows the cathode to be mounted on the centerline of a 6-kW Hall thruster, inside the iron core of the inner electromagnetic coil.

Although designed for electric propulsion thrusters in spacecraft station-keeping, orbit transfer, and inter-

planetary applications, the LaB_6 cathodes are applicable to the plasma processing industry in applications such as optical coatings and semiconductor processing where reactive gases are used. Where current electrical propulsion thrusters with BaO emitters have limited

life and need extremely clean propellant feed systems at a significant cost, these LaB₆ cathodes can run on the crudest-grade xenon propellant available without impact. Moreover, in a laboratory environment, LaB₆ cathodes reduce testing costs because they do not require extended conditioning periods under hard vacuum. Alternative rare earth emitters, such as cerium hexaboride (CeB₆) can be used in this configuration with possibly an even longer emitter life.

This cathode is specifically designed to integrate on the centerline of a high-power Hall thruster, thus eliminating the asymmetries in the plasma discharge common to cathodes previ-

ously mounted externally to the thruster's magnetic circuit. An alternative configuration for the cathode uses an external propellant feed. This diverts a fraction of the total cathode flow to an external feed, which can improve the cathode coupling efficiency at lower total mass flow rates. This can improve the overall thruster efficiency, thereby decreasing the required propellant loads for different missions. Depending on the particular mission, reductions in propellant loads can lead to mission enabling capabilities by allowing launch vehicle step-down, greater payload capability, or by extending the life of a spacecraft.

This work was done by Ronald Watkins of Columbus Technologies and Dan Goebel and Richard Hofer of Caltech for NASA's Jet Propulsion Laboratory. Further information is contained in a TSP (see page 1).

In accordance with Public Law 96-517, the contractor has elected to retain title to this invention. Inquiries concerning rights for its commercial use should be addressed to:

*Innovative Technology Assets Management
JPL*

Mail Stop 202-233

4800 Oak Grove Drive

Pasadena, CA 91109-8099

E-mail: iaoffice@jpl.nasa.gov

Refer to NPO-44923, volume and number of this NASA Tech Briefs issue, and the page number.

⚙️ High-Precision Shape Control of In-Space Deployable Large Membrane/Thin-Shell Reflectors

Real-time reflector surface figure control uses piezoelectric polymer actuators.

NASA's Jet Propulsion Laboratory, Pasadena, California

This innovation has been developed to improve the resolutions of future space-based active and passive microwave antennas for earth-science remote sensing missions by maintaining surface figure precisions of large membrane/thin-shell reflectors during orbiting. The intention

is for these sensing instruments to be deployable at orbit altitudes one or two orders of magnitude higher than Low Earth Orbit (LEO), but still being able to acquire measurements at spatial resolution and sensitivity similar to those of LEO. Because active and passive mi-

crowave remote sensors are able to penetrate through clouds to acquire vertical profile measurements of geophysical parameters, it is desirable to elevate them to the higher orbits to obtain orbital geometries that offer large spatial coverage and more frequent observations. This capability is essential for monitoring and for detailed understanding of the life cycles of natural hazards, such as hurricanes, tropical storms, flash floods, and tsunamis.

Major components of this high-precision antenna-surface-control system include a membrane/thin shell reflector, a metrology sensor, a controller, actuators, and corresponding power amplifier and signal conditioning electronics (see figure). Actuators are attached to the back of the reflector to produce contraction/expansion forces to adjust the shape of the thin-material reflector. The wavefront-sensing metrology system continuously measures the surface figure of the reflector, converts the surface figure to digital data and feeds the data to the controller. The controller determines the control parameters and generates commands to the actuator system. The flexible, piezoelectric polymer actuators are thus activated, providing the control forces needed to correct any distortions that exist in the reflector surface. Piezoelectric polymer actuators are very thin and flexible. They can be implemented on the back of the membrane/thin-shell

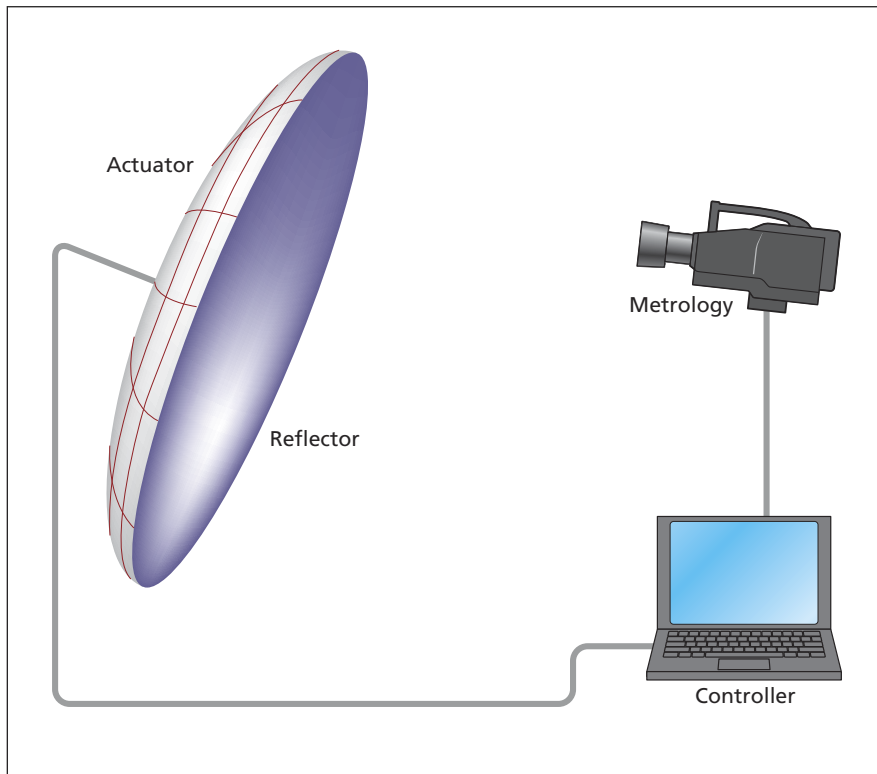

The Major Components of the antenna surface control system are illustrated.