



### Capacitors Would Help Protect Against Hypervelocity Impacts

Marshall Space Flight Center, Alabama

A proposal investigates alternatives to the present "bumper" method of protecting spacecraft against impacts of meteoroids and orbital debris. The proposed method is based on a British high-voltage-capacitance technique for protecting armored vehicles against shaped-charge warheads.

A shield, according to the proposal, would include a bare metal outer layer separated by a gap from an inner metal layer covered with an electrically insulating material. The metal layers would constitute electrodes of a capacitor. A

bias potential would be applied between the metal layers. A particle impacting at hypervelocity on the outer metal layer would break apart into a debris cloud that would penetrate the electrical insulation on the inner metal layer. The cloud would form a path along which electric current could flow between the metal layers, thereby causing the capacitor to discharge. With proper design, the discharge current would be large enough to vaporize the particles in the debris cloud to prevent penetration of the spacecraft.

The shield design can be mass optimized to be competitive with existing bumper designs. Parametric studies were proposed to determine optimum correction between bias voltage, impacting particle velocity, gap space, and insulating material required to prevent spacecraft penetration.

*This work was done by David Edwards, Whitney Hubbs, and Mary Hovater of Marshall Space Flight Center. Further information is contained in a TSP (see page 1).*

MFS-31995-1

### Diaphragm Pump With Resonant Piezoelectric Drive

Resonance is used to amplify the stroke and thus the flow rate.

Lyndon B. Johnson Space Center, Houston, Texas

A diaphragm pump driven by a piezoelectric actuator is undergoing development. This pump is intended to be a prototype of lightweight, highly reliable pumps for circulating cooling liquids in protective garments and high-power electronic circuits, and perhaps for some medical applications. The pump would be highly reliable because it would contain no sliding seals or bearings that could wear, the only parts subject to wear would be two check valves, and the diaphragm and other flexing parts could be designed, by use of proven methods, for extremely long life. Because the pump would be capable of a large volumetric flow rate and would have only a small dead volume, its operation would not be disrupted by ingestion of gas, and it could be started reliably under all conditions.

The prior art includes a number piezoelectrically actuated diaphragm pumps. Because of the smallness of the motions of piezoelectric actuators (typical maximum strains only about 0.001), the volumetric flow rates of those pumps are much too small for typical cooling applications. In the pump now undergoing development, mechanical resonance would be utilized to amplify the motion generated by the piezoelectric actuator and

thereby multiply the volumetric flow rate.

The prime mover in this pump would be a stack of piezoelectric ceramic actuators, one end of which would be connected to a spring that would be part of a spring-and-mass resonator structure. The "mass" part of the resonator struc-

ture would include the pump diaphragm (see Figure 1). Contraction of the spring would draw the diaphragm to the left, causing the volume of the fluid chamber to increase and thereby causing fluid to flow into the chamber. Subsequent expansion of the spring would

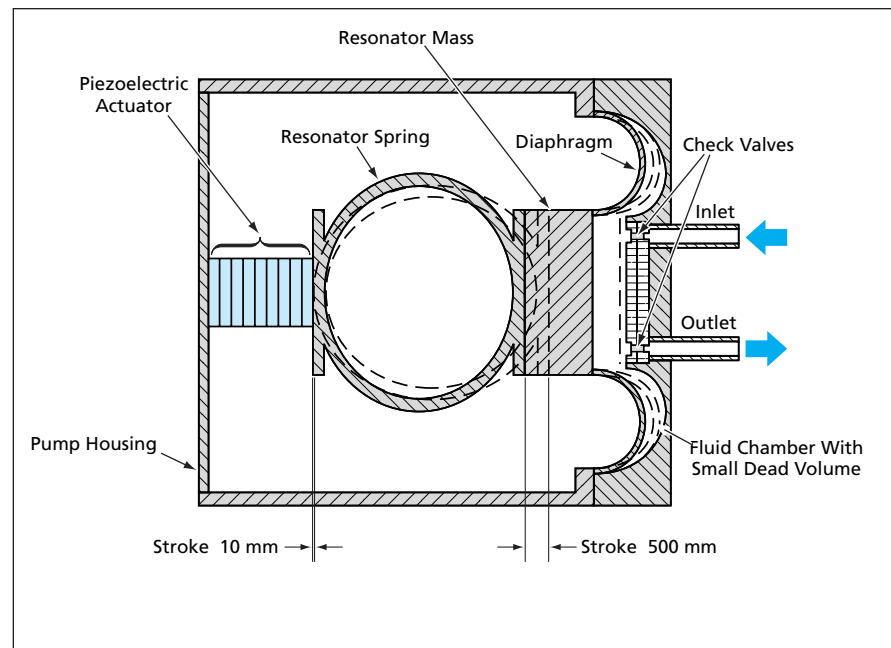

Figure 1. The Spring-and-Mass Resonator, if properly designed and constructed, would amplify the stroke of the piezoelectric stack by a factor of the order of 20.

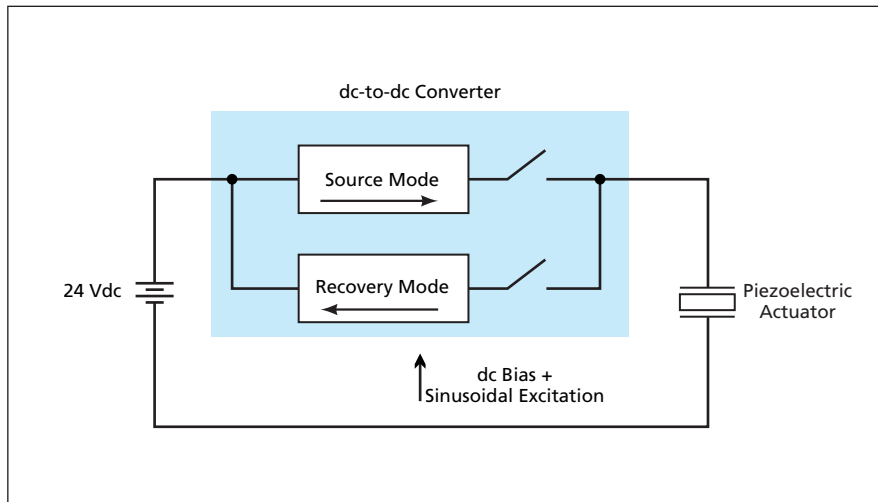

Figure 2. This Circuit Would Recover Energy returned by the piezoelectric actuator during each cycle of oscillation, thereby minimizing the power demand of the pump.

push the diaphragm to the right, causing the volume of the fluid chamber to decrease, and thereby expelling fluid from the chamber. The fluid would enter and leave the chamber through check valves.

The piezoelectric stack would be driven electrically to make it oscillate at the resonance frequency of the spring-and-mass structure. This frequency could be made high enough (of the order of 400 Hz) that the masses of all components could be made conve-

niently small. The resonance would amplify the relatively small motion of the piezoelectric stack (a stroke of the order of 10  $\mu\text{m}$ ) to a diaphragm stroke of the order of 0.5 mm. The exact amplification factor would depend on the rate of damping of oscillations; this, in turn, would depend on details of design and operation, including (but not limited to) the desired pressure rise and volumetric flow rate. In order to obtain resonance with large displacement, the damping rate must be low enough that

the energy imparted to the pumped fluid on each stroke is much less than the kinetic and potential energy exchanged between the mass and spring during each cycle of oscillation.

To minimize the power demand of the pump, a highly efficient drive circuit would be used to excite the piezoelectric stack. This circuit (see Figure 2) would amount to a special-purpose regenerative, switching power supply that would operate in a power-source mode during the part of an oscillation cycle when the excitation waveform was positive and in a power-recovery mode during the part of the cycle when the excitation waveform was negative. The circuit would include a voltage-boosting dc-to-dc converter that would convert between a supply potential of 24 Vdc and the high voltage needed to drive the piezoelectric stack. Because of the power-recovery feature, the circuit would consume little power. It should be possible to build the circuit as a compact unit, using readily available components.

*This work was done by Michael G. Izenson, Robert J. Kline-Schoder, and Martin A. Shimko of Creare, Inc. for Johnson Space Center. For further information, contact the Johnson Commercial Technology Office at (281) 483-3809. MSC-23112*

## Improved Quick-Release Pin Mechanism

Lyndon B. Johnson Space Center, Houston, Texas

An improved quick-release pin mechanism supplants a prior such mechanism in which the pin bears a shear load to hold two objects together. The prior mechanism, of a ball-locking design, can fail when vibrations cause balls to fall out. The load-bearing pin is an outer tube with a handle at one end (hereafter denoted the near end). Within the outer tube is a spring-loaded inner tube that includes a handle at its near end and a

pivoting tab at its far end. The pin is inserted through holes in the objects to be retained and the inner tube is pushed against an offset pivot inside the outer tube to make the tab rotate outward so that it protrudes past the outer diameter of the outer tube, and the spring load maintains this configuration so that the pin cannot be withdrawn through the holes. Pushing the handles together against the spring load moves the lock-

ing tab out far enough that the tab becomes free to rotate inward. Then releasing the inner-tube handle causes the tab to be pulled into a resting position inside the outer tube. The pin can then be pulled out through the holes.

*This work was done by Jay M. Wright of Johnson Space Center. For further information, contact the Johnson Innovative Partnerships Office at (281) 483-3809. MSC-23298*

## Designing Rolling-Element Bearings

Marshall Space Flight Center, Alabama

Bearing Analysis Tool (BAT) is a computer program for designing rolling-element bearings for cryogenic turbomachines. BAT provides a graphical user interface (GUI) that guides the entry of data to develop mathematical models

of bearings. The GUI breaks model data into logical subsets that are entered through logic-driven input screens. The software generates a three-dimensional graphical model of a bearing as the data are entered. Most data-

entry errors become immediately obvious in the graphical model. BAT provides for storage of all the data on a shaft/bearing system, enabling the creation of a library of proven designs. Data from the library can be trans-