

Active Flow Control of Lifting Surface With Flap – Current Activities and Future Directions

G. Ahmadi, P. Marzocca, R. Jha,
B. Alstorm, S. Obied, P. Kabir and A. Shahrabi

Department of Mechanical and Aeronautical Engineering
Clarkson University, Potsdam, NY 13699-5725

Outline

- **Objectives**
- **Design of the Experimental Airfoil**
- **Synthetic Jet**
- **Control Strategies**
- **Future Plans**
- **Concluding remarks**

Airfoil With Hinged Flap

The main objective is to develop effective active control strategies for separation control of an airfoil with a single hinge flap. The specific objectives are:

- **Develop of an active control architecture for flow control around an airfoil with flap.**
- **Design, fabricate, and wind tunnel test of a high lift wing (with flap) with integrated actuators and sensors.**

- **Design, development and fabrication of synthetic jet actuators. Performance testing of the synthetic jet actuators.**
- **Develop appropriate control strategy for application to the airfoil.**
- **Wind tunnel testing of the high lift wing at various angles of attack and flap positions with closed loop flow control.**

Wind Tunnel Setup

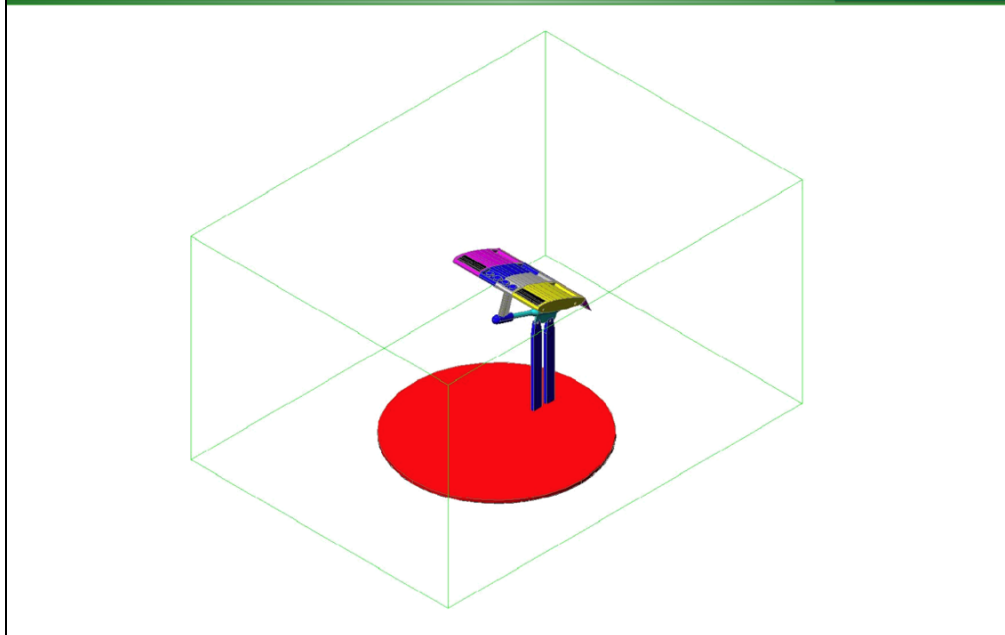

Wind Tunnel Setup

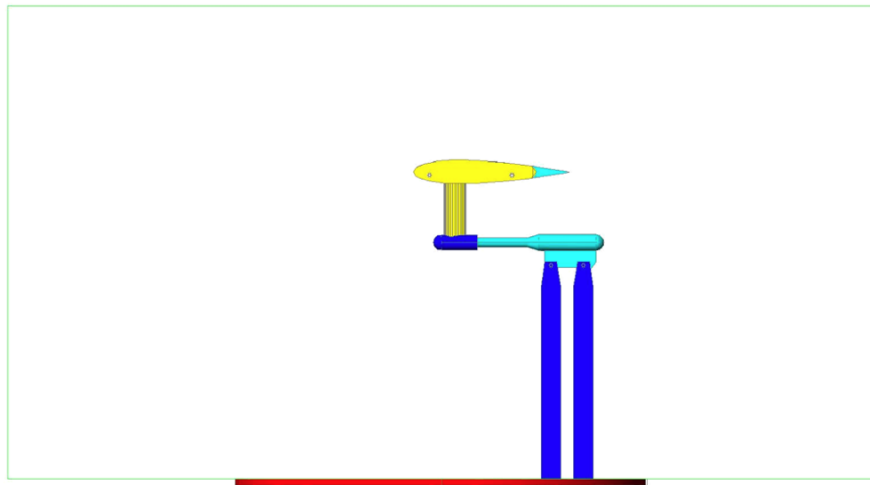

Wing With Circular Endplates

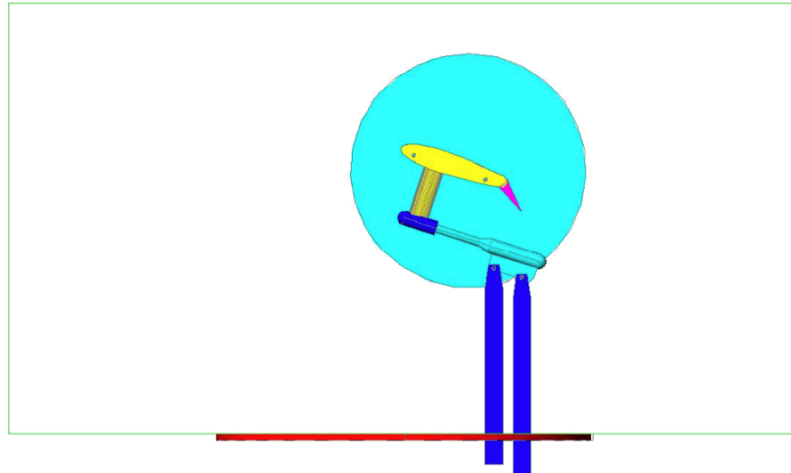

Separation Control

Kiedaisch et al. used steady blowing (open loop)
Pneumatic system for flow control actuators

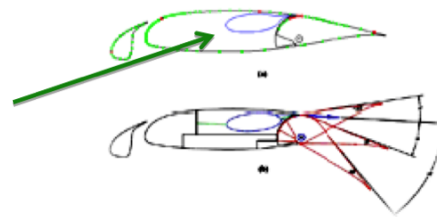

Kiedaisch et al. (2007)

Melton et al used piezo-based actuator (open loop)

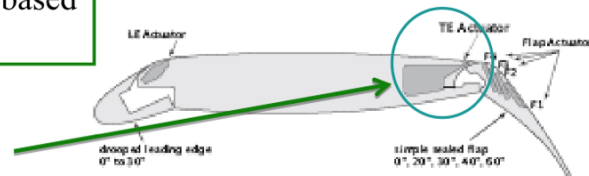

Melton et al. (2006)

The intent of this slide is to introduce flow control experimental that have a similar wing configuration.

- The unused TE actuator cavity is similar to the Clarkson AFOSR Wing

Airfoil With Hinged Flap

Clarkson
UNIVERSITY

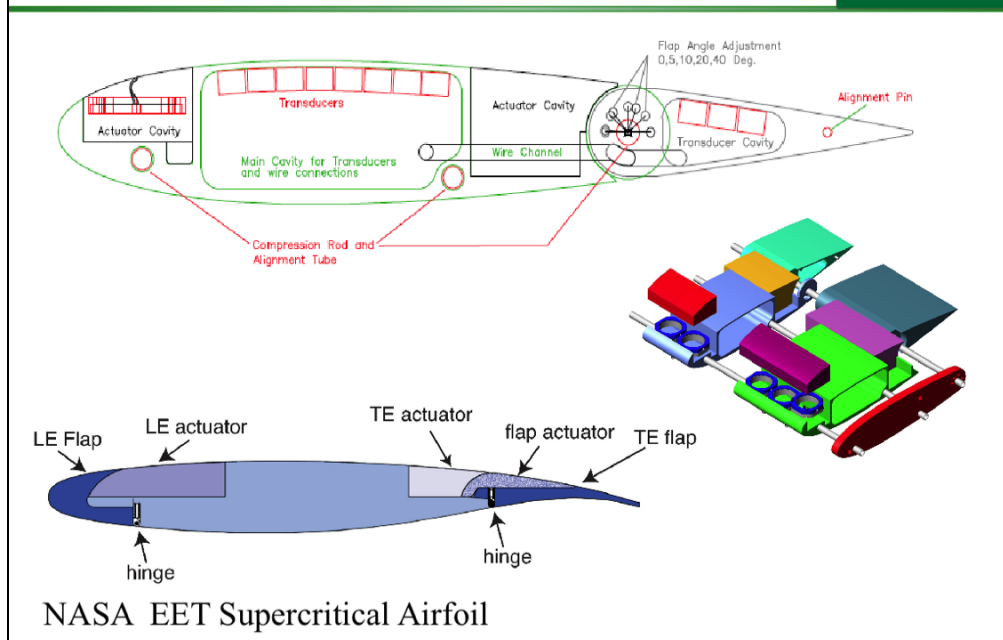

**You may wish to point out that the TE actuator cavity on the NASA EET wing is similar to ours and note also the LE actuator is at angle to the surface of the wing

Technical Challenges (Actuators)

1. The use and configuration of piezo-based ZNMF actuators; specifically the use of unimorphs and the enclosure/cavity design to produce the frequency response required to force the flow at its coupled natural frequencies (Separation bubble, Shear layer and Wake frequencies)

2. Orifice depth and orientation of the jet; typically the orifice is a straight rectangular or axisymmetric channel through which the jet is issued. It has been suggested by Williams and Fabris [2000] and Rowley [2001] that the actuator is more effective when the slot is oriented in the streamwise direction and less than 45 degrees the surface of wing. This design criterion can be applied to Zero Net Mass Flux actuators (as opposed to Positive Net Mass Flux actuators Shaw [1998])

These technical challenges will be discussed in the next few slides: **Jet Actuator Bench Test Articles Synthetic**

Wing Design

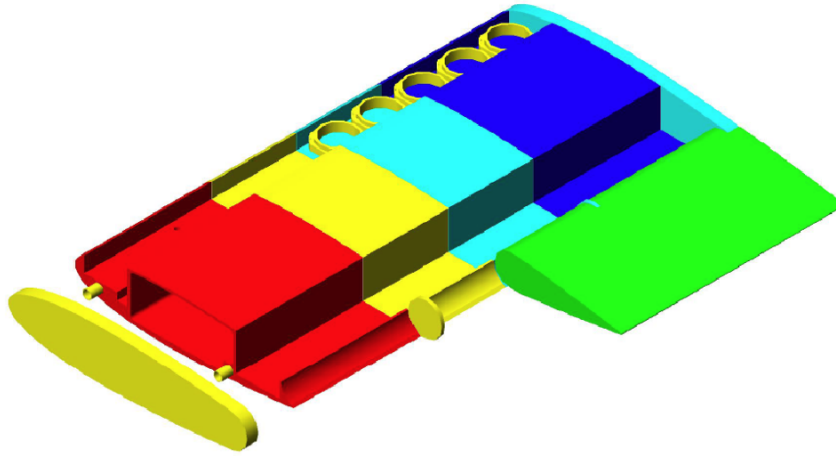

Wing Design

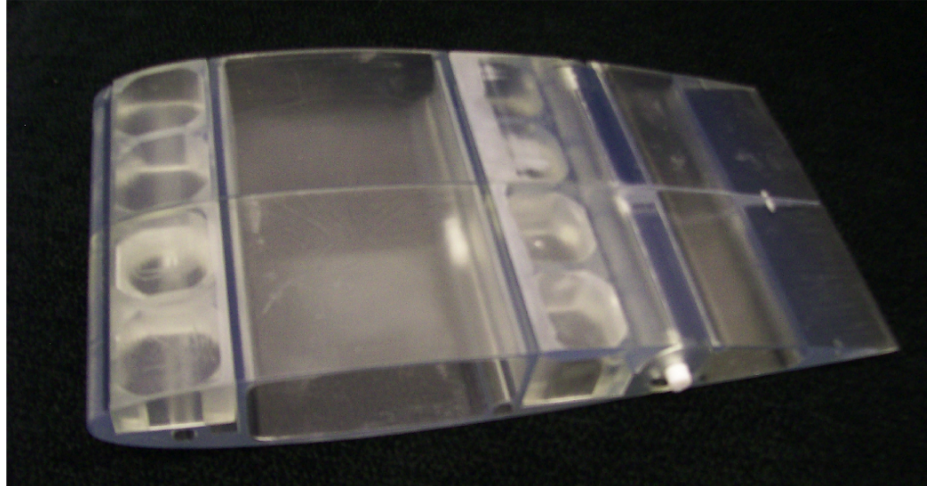

Wing Design

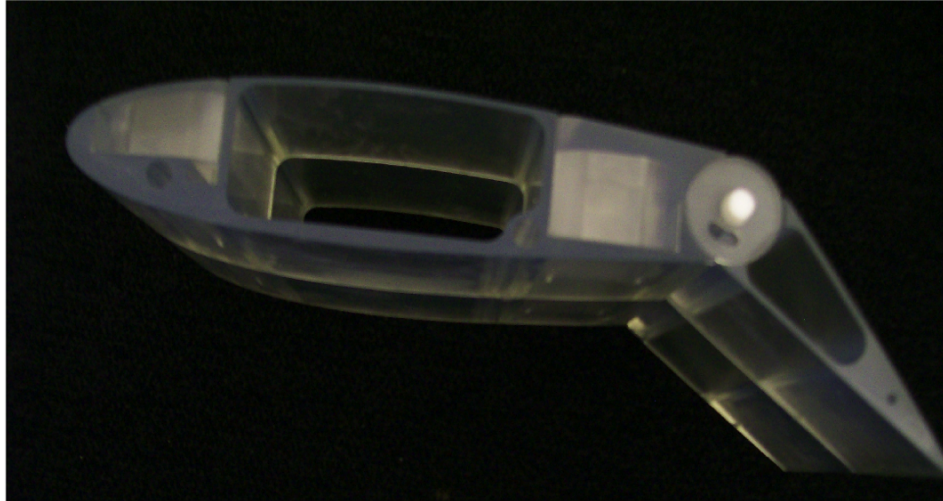

CFD Modeling

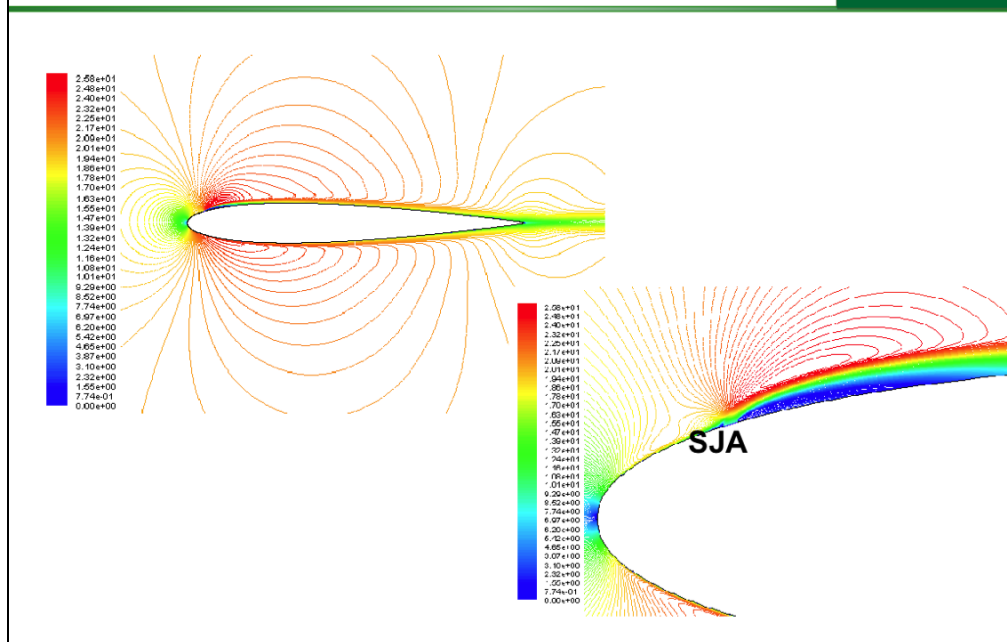

CFD Modeling

Clarkson
UNIVERSITY

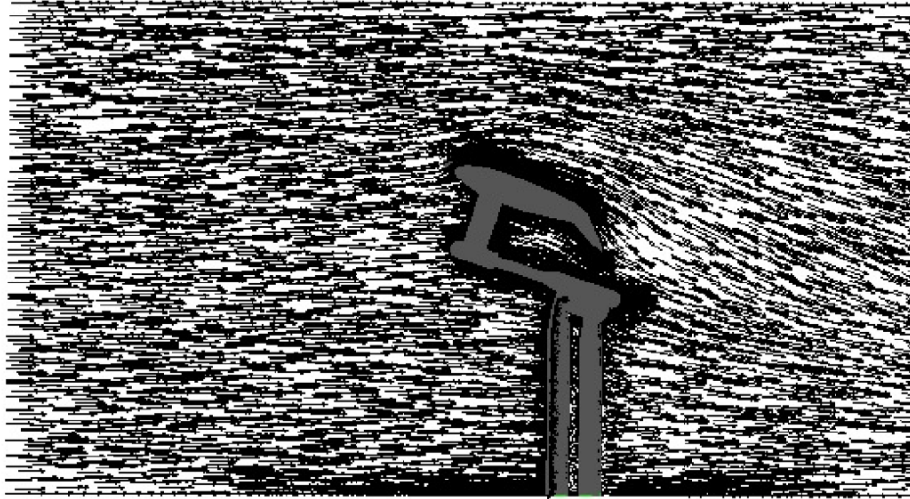

Synthetic Jet Actuators

Design Approaches:

- Design for maximum velocity (Rathnasingham & Breuer, 1997); Lockerby & Carpenter, 2004)
- Design for a broad bandwidth (Gallas, 2003)

Wing cavity space imposes constraints on the design a piezo-based actuator to achieve a broad frequency response whose natural frequency is centered at less than or equal to 500 Hz.

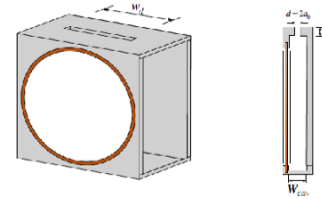
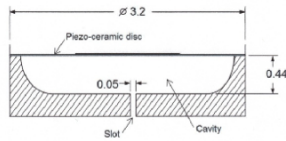
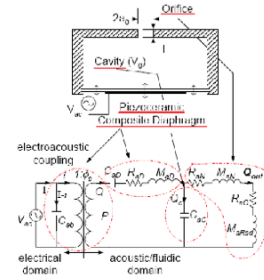

SJA Test Using Hot-Wire Anemometry

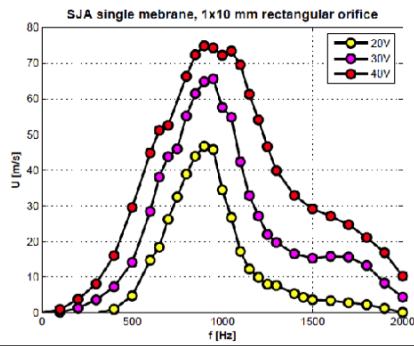
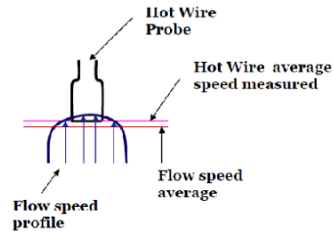

SJA specification	
Membrane type	SJM1
Slot width	10 mm
Slot height	1 mm
Orifice neck length	4 mm
Cavity volume	$\approx 1.1787e-6 \text{ m}^3$

SJA Test Using Hot-Wire Anemometry

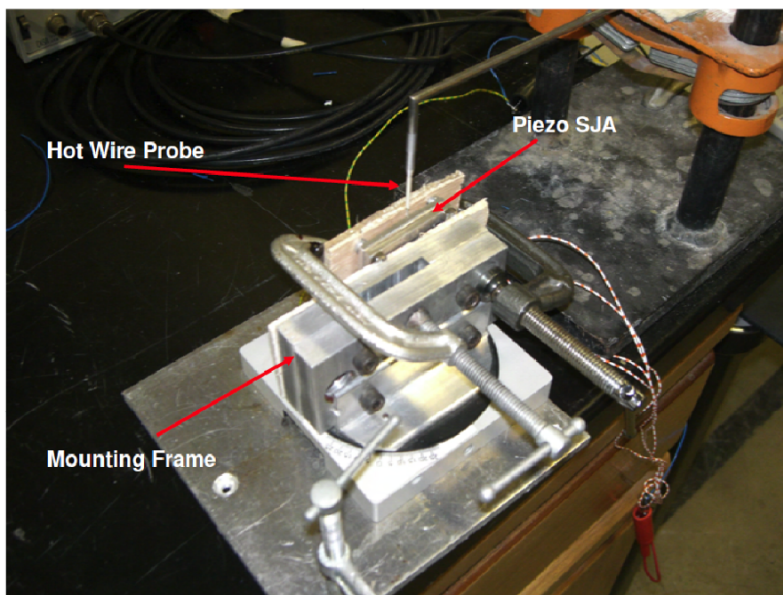

Synthetic Jet Actuators

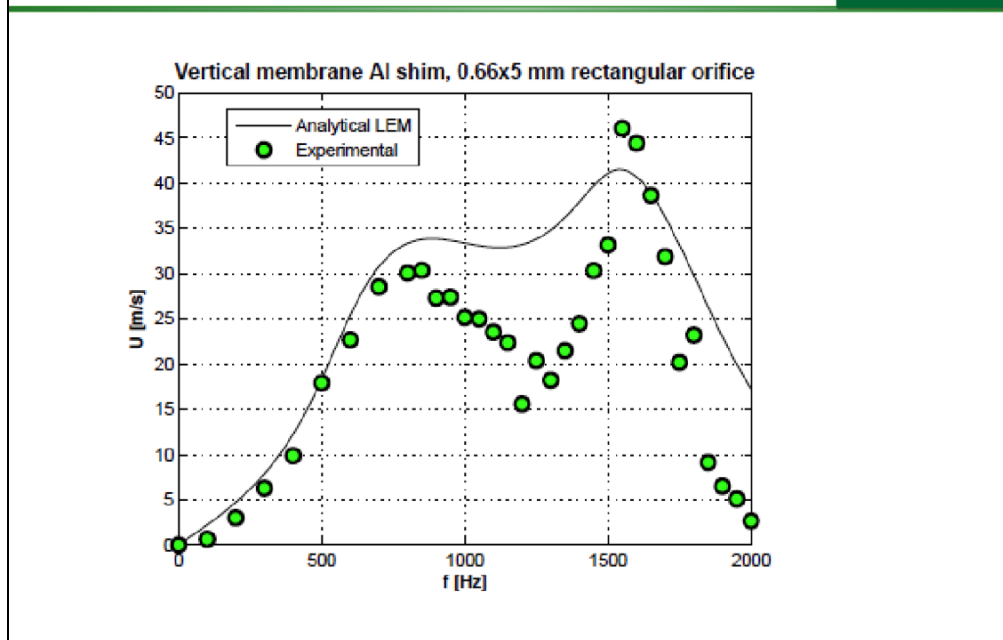

These are the results of some experimental work on SJA at Clarkson (Nicolini & Marzocca). After much discussion, we thought it might be advantageous to have an actuator who's frequency response has peaks close together forming a broad bandwidth actuator.

Synthetic Jet Actuators

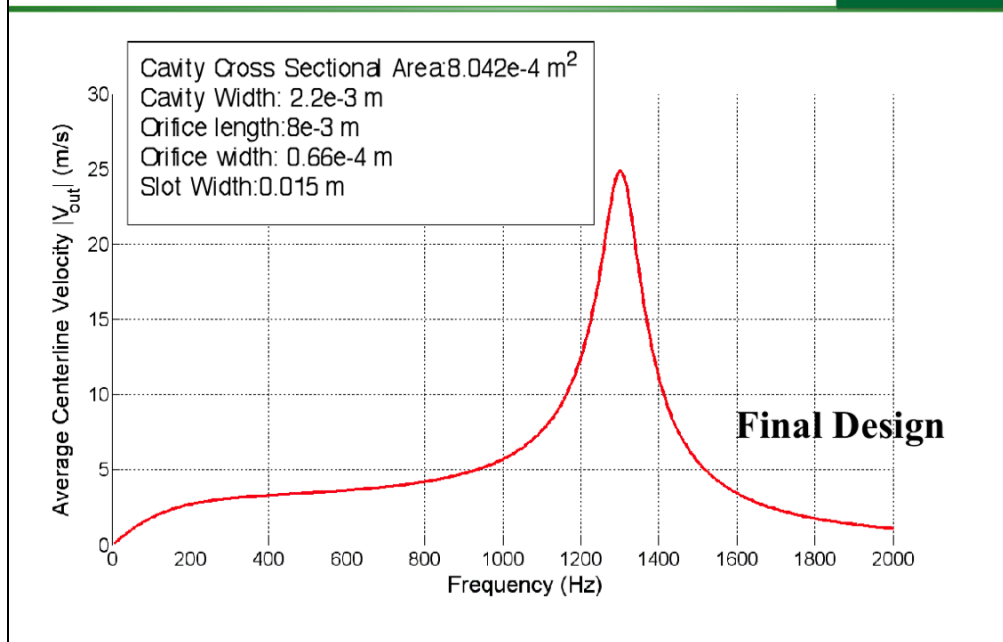

Nonlinear_loss_coefficient = 1

Cavity_cross_sectional_area(m²) = 8.042×10^{-4}

Cavity_width(m) = 2.2×10^{-3}

Orifice_length(m) = 8×10^{-3}

Orifice_radius(m) = 0.66×10^{-4}

Slot_width(m) = 0.015

Synthetic Jet Actuators

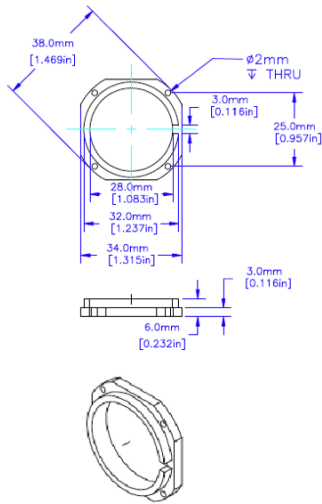

Bottom Ring

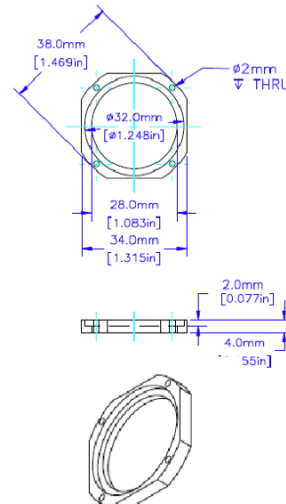

Top Ring

Synthetic Jet Actuators

Assembly

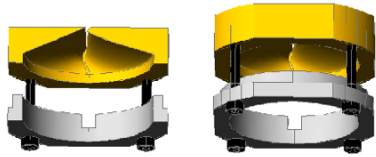

Type I

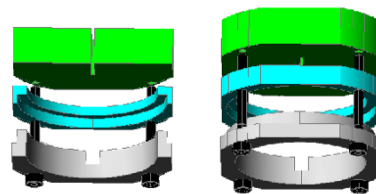

Type II

Here are the synthetic jet actuator assemblies: Here you can see the bottom and top rings and the covers with the orifices. Note the notch on the bottom rings; this is for the leads from the piezo benders.

The horn is generic here.

Control Strategies

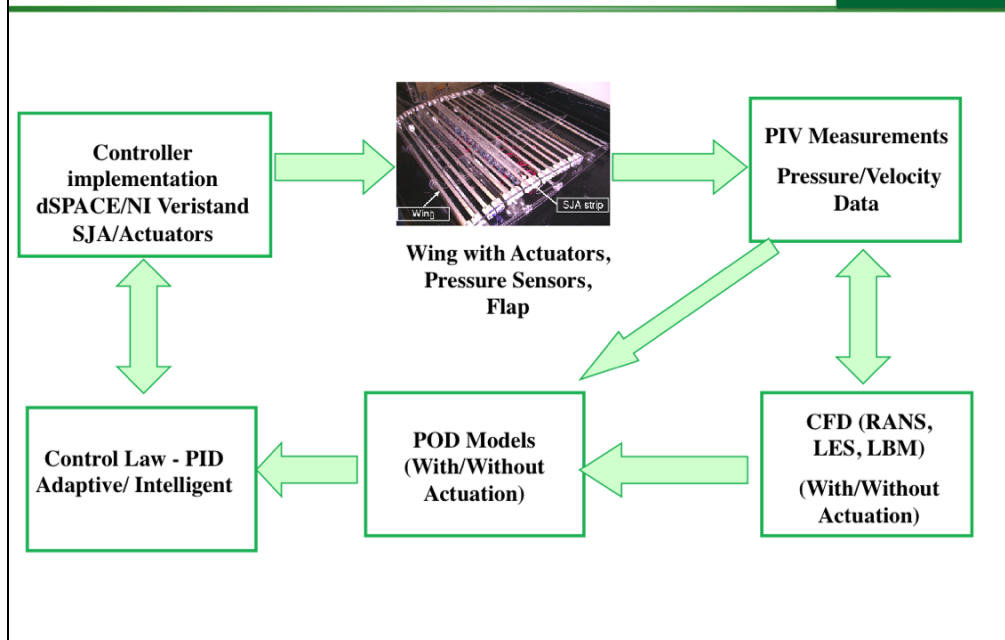

- Control system architecture (PID, LQR, Adaptive, Hybrid)
- Model based (POD/mLSE), System ID based
- Actuator – SJA (characteristics, number, location)
- Sensor – Surface pressure (type, number, location)
- Frequencies (SJA resonance, characteristic flow frequencies wake, shear layer, separation bubble)
- Implementation – SISO, MIMO
- Stability and robustness (unmodeled dynamics, uncertainties)
- ➡ **Complex dynamical system (turbulent, separated)**
Begin with simple controller and proceed carefully!

POD Based Controller

Turret flow control using pressure field POD (SU/AFRL, 2008)

Three different POD used for control

- Baseline POD

- Baseline+Actuated Lumped

- Split-POD (Baseline and Actuated/Orthogonal components)

Future Work Experimental Wing

- **Actuator Fabrication and Testing**
- **Actuator Array fabrication and assembly**
- **Integration into Clarkson AFOSR Wing**
- **Wing Tunnel Testing**

- The SJA Bench Test Articles (there are 2; an 1mm and 8mm orifice) will be characterized using a hot wire anemometry
- In addition an enclosure and horn will be manufactured and characterized also.

- The characterization results of the 3 actuators will compared. As our understanding of the compression driver horn combination improves; we will then explore in earnest what is required to integrate this type of actuator into the wing

Future Work

- **Two-Point Correlation –POD base**
- **Implementation of control Algorithm**
- **Testing and Assessment**

Acknowledgements

Clarkson-Syracuse-AFRL Collaborative Effort

The support of AFOSR/AFRL is gratefully acknowledged.

Thank you!

Questions?

Synthetic Jet Actuators

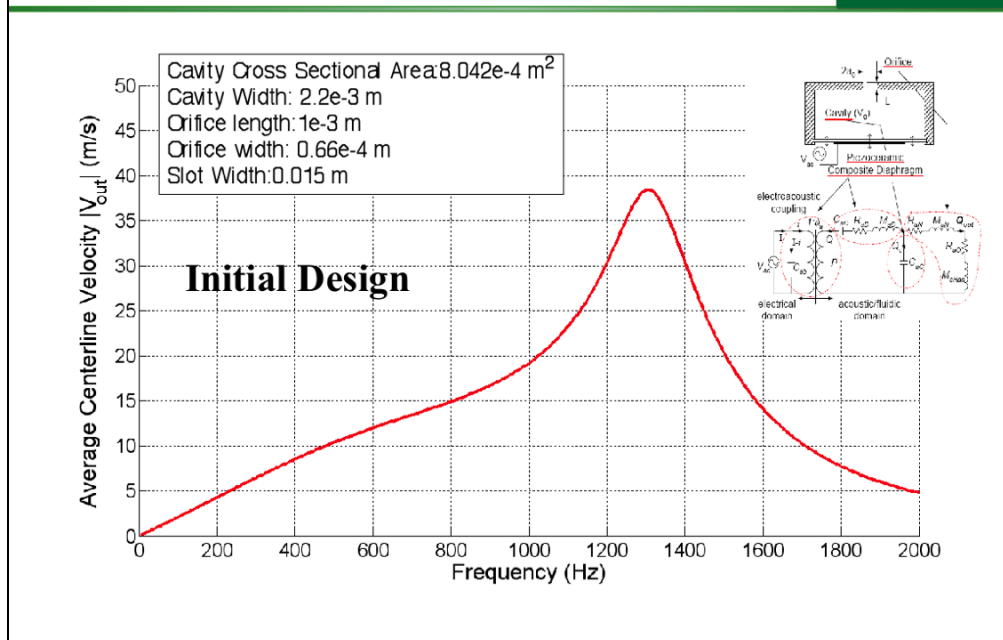

This is the initial design. The orifice length is 1 mm

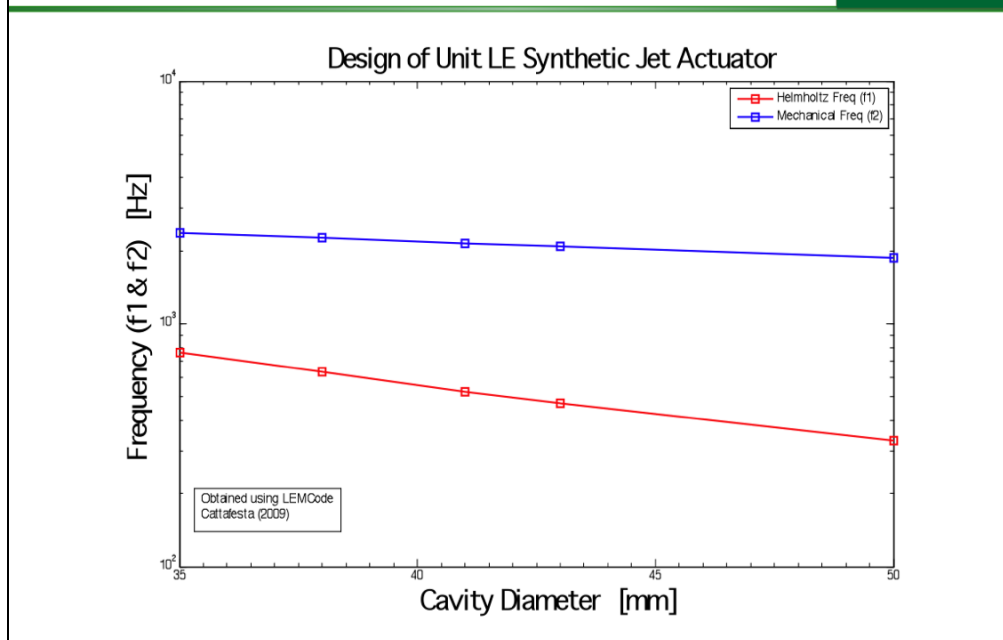

As the cavity diameter increases, the mechanical frequency of the unimorph decreases, but very slowly; indicating that we would have to use a much larger unimorph to achieve a $f < 1000$ Hz