

theme parks — a far cry from the utilitarian scope of neutral immersion as conceived in the early days of space-flight. Florooms would enable users to share experiences on a large scale — for example, immersive rock concerts or sporting events. A floroom could contain hundreds of flostations.

At present, the flostation is available in two versions. One is a static version, which includes the chair portion (the flochair) equipped with a hemispherical screen (the flodome) that is lowered over the occupant's head so the occupant's eyes are at the center of the dome

and the field of view is filled by an image generated on a standard liquid-crystal-display projector. The static version also includes shakers and loudspeakers mounted on a simple motorized reclining base. The other version is a dynamic one in that the flochair is mounted on a six-degree-of-freedom hydraulic base. The static version is intended for public and home use; the dynamic version is better suited to the space program.

Flostations could prove beneficial in applications beyond the space program for which they were originally developed. For example, they might be used

in medicine for pain-reduction therapy or to treat psychoses.

This work was done by Brian Park of Flogiston Corp. for Johnson Space Center.

In accordance with Public Law 96-517, the contractor has elected to retain title to this invention. Inquiries concerning rights for its commercial use should be addressed to:

*Flogiston Corp.
16921 Crystal Cave Drive
Austin, TX 78737*

Refer to MSC-22932, volume and number of this NASA Tech Briefs issue, and the page number.

Algorithm for Aligning an Array of Receiving Radio Antennas

Relative to prior such algorithms, this one requires less hardware.

NASA's Jet Propulsion Laboratory, Pasadena, California

A digital-signal-processing algorithm (somewhat arbitrarily) called "SUMPLE" has been devised as a means of aligning the outputs of multiple receiving radio antennas in a large array for the purpose of receiving a weak signal transmitted by a single distant source. As used here, "aligning" signifies adjusting the delays and phases of the outputs from the various antennas so that their relatively weak replicas of the desired signal can be added coherently to increase the signal-to-noise ratio (SNR) for improved reception, as though one had a single larger antenna. The method was devised to enhance spacecraft-tracking and telemetry operations in NASA's Deep Space Network (DSN); the method could also be useful in such other applications as both satellite and terrestrial radio communications and radio astronomy.

Heretofore, most commonly, alignment has been effected by a process that involves correlation of signals in pairs. This approach necessitates the use of a large amount of hardware — most notably, the $N(N-1)/2$ correlators needed to process signals from all possible pairs of N antennas. Moreover, because the incoming signals typically have low SNRs, the delay and phase adjustments are poorly determined from the pairwise correlations.

SUMPLE also involves correlations, but the correlations are not performed in pairs. Instead, in a partly iterative process, each signal is appropriately weighted and then correlated with a composite signal equal to the sum of the other signals (see Figure 1). One benefit

of this approach is that only N correlation phase wandering: In some other methods

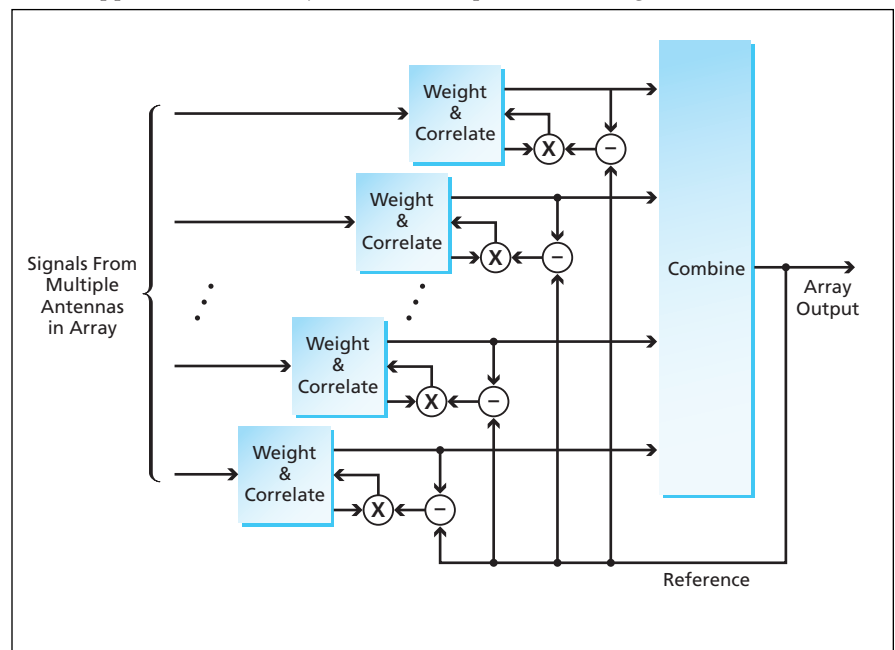

Figure 1. SUMPLE is a digital-signal-processing algorithm in which the signal received by each antenna in an array is correlated with the sum of all the other signals.

tors are needed; in an array of $N \gg 1$ antennas, this results in a significant reduction of the amount of hardware. Another benefit is that once the array achieves coherence, the correlation SNR is $N-1$ times that of a pair of antennas.

Two questions about the performance of SUMPLE have been investigated by computational simulation. The first question is that of how SUMPLE performs at the beginning of a signal-processing pass, before coherence is achieved among the antennas. The second is a question of

of correlation, one antenna is designated the reference antenna and all the other antennas are brought into alignment with it. However, in SUMPLE, all the antennas are aligned to what amounts to a "floating" reference. There is concern as to whether the phase of the floating reference wanders as a function of time, introducing unknown phase instability.

In one simulation, the combining loss as a function of time (equivalently, as a function of the number of iterations) was computed for a 100-antenna array by

use of SUMPLE. At the beginning of the simulated reception process, the signal phases were taken to be random, resulting in a very large combining loss. The

combining loss was found to decrease to a few tenths of a decibel in about eight iterations and to remain at this level thereafter (see Figure 2). Simulations of

many different array configurations yielded essentially the same results.

Answering the question of phase wandering, the simulations did, indeed, show slow phase variations of a few degrees over time intervals of 10 to 20 iterations. However, it was found that this wandering could be prevented by forcing, to zero, the total phase correction obtained by summing the individual corrections over all the antennas. Inasmuch as the phase corrections are meant to bring the antenna signals into alignment with each other, forcing the total phase correction to zero does not pose an obstacle to the achievement of array coherence.

SUMPLE has been tested on an array of 34-m-diameter antennas in the DSN. The results of this test have been found to agree with those of the simulations.

This work was done by David Rogstad of Caltech for NASA's Jet Propulsion Laboratory. Further information is contained in a TSP (see page 1).

The software used in this innovation is available for commercial licensing. Please contact Karina Edmonds of the California Institute of Technology at (818) 393-2827. Refer to NPO-40574.

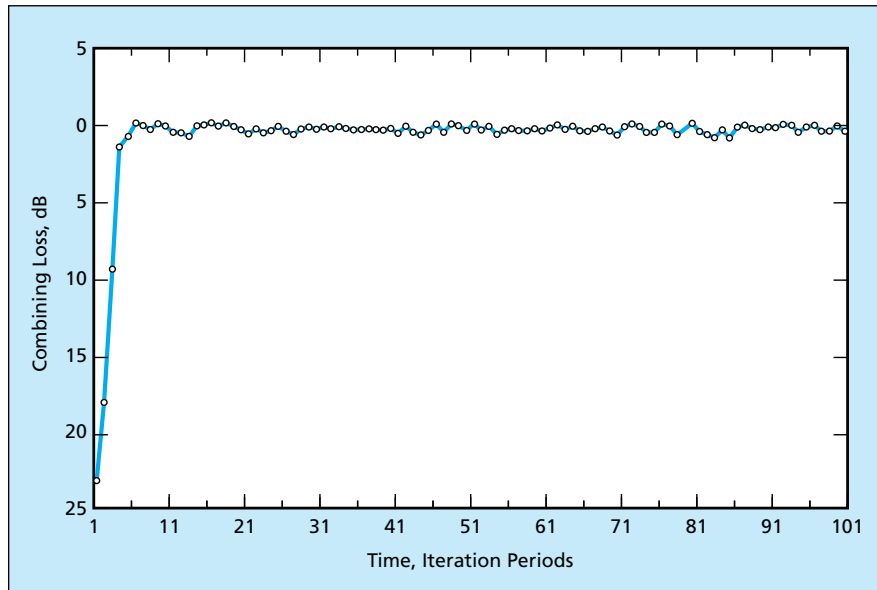

Figure 2. The Combining Loss of a 100-antenna array using SUMPLE was simulated for reception of a representative telemetry signal. The unit of time on the abscissa is an iteration period defined, for the purpose of this specific example, as an integration time of 5,000 telemetry-symbol periods.

Single-Chip T/R Module for 1.2 GHz

T/R modules can be made smaller and at lower cost.

NASA's Jet Propulsion Laboratory, Pasadena, California

A single-chip CMOS-based (complementary-metal-oxide-semiconductor-based) transmit/receive (T/R) module is being developed for L-band radar systems. Previous T/R module implementations required multiple chips employing different technologies (GaAs, Si, and others) combined with off-chip transmission lines and discrete components including circulators. The new design eliminates the bulky circulator, significantly reducing the size and mass of the T/R module.

Compared to multi-chip designs, the single-chip CMOS can be implemented with lower cost. These innovations enable cost-effective realization of advanced phased array and synthetic aperture radar systems that require integration of thousands of T/R modules.

The circulator is a ferromagnetic device that directs the flow of the RF (radio frequency) power during transmission and reception. During transmission, the circulator delivers the transmitted power from

the amplifier to the antenna, while preventing it from damaging the sensitive receiver circuitry. During reception, the circulator directs the energy from the antenna to the low-noise amplifier (LNA) while isolating the output of the power amplifier (PA). In principle, a circulator could be replaced by series transistors acting as electronic switches. However, in practice, the integration of conventional series transistors into a T/R chip introduces significant losses and noise.

The prototype single-chip T/R module contains integrated transistor switches, but not connected in series; instead, they are connected in a shunt configuration with resonant circuits (see figure). The shunt/resonant circuit topology not only reduces the losses associated with conventional semiconductor switches but also provides beneficial transformation of impedances for the PA and the LNA. It provides full single-pole/double-throw switching for the antenna, isolating the LNA from the transmitted signal and isolating the PA from the received signal. During reception,

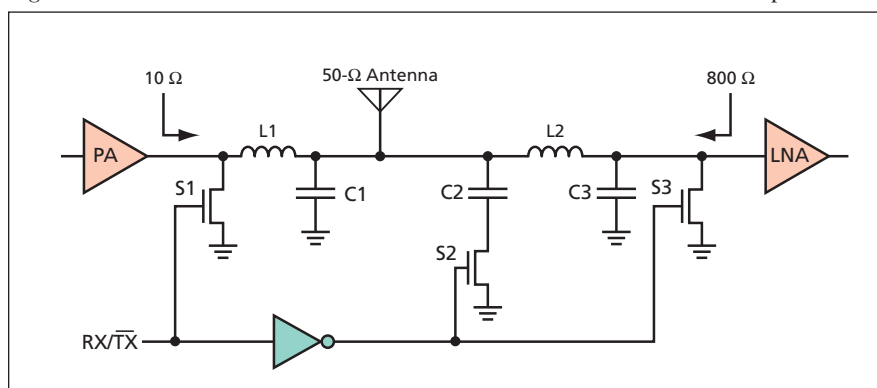

A 1.2-GHz Single-Chip T/R Circuit for a radar system eliminates a bulky circulator.