

## ELECTRODYNAMIC PROPULSION SYSTEM TETHER EXPERIMENT (T-REX)

L. Johnson  
NASA George C. Marshall Space Flight Center  
Huntsville, Alabama  
[c.les.johnson@nasa.gov](mailto:c.les.johnson@nasa.gov)

H. A. Fujii  
Kanagawa Institute of Technology  
Tokyo, Japan

J. R. Sanmartin  
Universidad Politecnica de Madrid  
Madrid, Spain

### ABSTRACT

A Japanese-led international team is developing a suborbital test of orbital-motion-limited (OML) bare wire anode current collection for application to electrodynamic tether (EDT) propulsion. The tether is a tape with a width of 25 mm, thickness of 0.05 mm, and is 300 m in length. This will be the first space test of OML theory. The mission will launch in the summer of 2010 using an S520 Sounding Rocket. During ascent, and above  $\approx 100$  km in attitude, the tape tether will be deployed at a rate of  $\approx 8$  m/s. Once deployed, the tape tether will serve as an anode, collecting ionospheric electrons. The electrons will be expelled into space by a hollow cathode device, thereby completing the circuit and allowing current to flow. The total amount of current collected will be used to assess the validity of OML theory. This paper will describe the objectives of the proposed mission, the technologies to be employed, and the application of the results to future space missions using EDTs for propulsion or power generation.

### NOMENCLATURE

$e$	electron charge
$I_e$	electron current
$I_i$	ion current
$L_b$	length of conductive beam
$L_t$	length of the tether
$m_e$	electron mass
$m_i$	ion mass
$N_\infty$	plasma density
$R_b$	radius of the boom
$T$	time
$w_b$	width of conductive beam
$w_t$	width of the tether
$\alpha$	proportionality constant
$\varepsilon$	supply voltage
$\gamma$	yield per unit bias (electrons per kV and impacting ion)

## INTRODUCTION

Selected by the Japan Aerospace Education Agency (JAXA) in 2007 for flight in 2010, a team of researchers led by Professor Fujii at Kanagawa Institute of Technology will develop and fly a sounding rocket payload that, for the first time, will demonstrate bare wire electron collection by an EDT in space.<sup>1</sup> Data sufficient to validate the performance of the bare wire anode's performance as predicted by OML theory will be obtained. In addition, the overall current collection efficiency of the tether system will be used to update performance models of future EDT propulsion and power systems being considered for space application by NASA, JAXA, and others.

## RESULTS AND DISCUSSION

### EXPERIMENT OBJECTIVES

The objectives of the experiment are summarized in Table 1.

**Table 1. The engineering and science objectives of the space tether experiment (T-Rex).**

Objective	Comment
Fast deployment of a bare EDT	Engineering: Deploy a bare, conductive tape tether in space
Fast ignition of a hollow cathode	Engineering: Ignite a hollow cathode in space for 180 s
Dynamics of tethered space robot	Engineering: Analyze a tethered robot system for a deployment/retrieval maneuver
Verification of EDT operation in ionospheric plasma	Science: Eject electrons from an ignited hollow cathode and collect electrons by using a bare EDT
Verification of OML theory	Science: Measure electron collection by a positively biased boom and a negatively biased bare EDT

The rocket will first deploy a 300-m aluminum tape tether within minutes of launch. The bias voltage of the vertically deployed tether, which results just from its orbital motion through Earth's magnetic field, is positive with respect to the ambient plasma at the top and negative at the bottom. The tether generates and forms part of a unique type of electrical circuit, which has been successfully demonstrated in space by flights of the plasma motor generator (PMG) in 1993<sup>2</sup> and the Tethered Satellite Systems (TSS-1 and TSS-1R) in 1992 and 1996.<sup>3</sup> Both missions deployed long conducting tethers from orbiting spacecraft and successfully generated a current. The tethered system extracts electrons from the ionospheric plasma at one end (upper or lower, depending upon the deployment direction and intended thrust motion) and then carries them through the tether to the other end, where they are returned to the plasma. The circuit is completed by currents in the plasma.<sup>4</sup>

The efficiency with which electrons are collected is predicted by a theory, which applies when their Debye length is much greater than the object's size—as it can also be stated, when the object is small with respect to its sheath size. This theory is known as OML.<sup>5</sup> The uninsulated tether will collect electrons along part of its length. The efficiency with which it collects will be used to determine the validity of OML predictions.

### EXPERIMENT IMPLEMENTATION

After launch, the sounding rocket will achieve a maximum altitude of  $\approx 300$  km. During ascent, a round conductive boom with a diameter of 1 cm and length of 20 m will be deployed, followed by the 300-m tape tether. The overall mission timeline is shown in Figure 1.

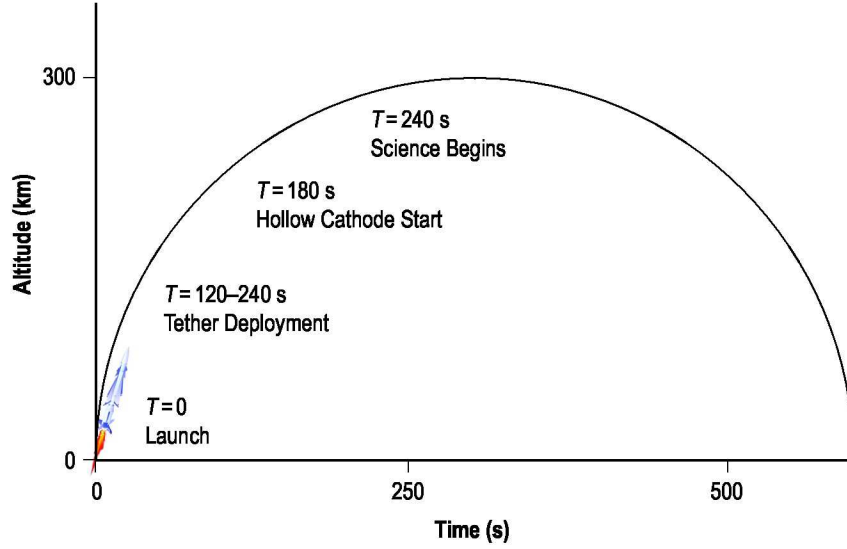

**Figure 1. Mission timeline from launch at  $T = 0$ .**

At the first stage of the experiment, the positive terminal of power supply is connected to the conductive boom with length,  $L_b$ , and the negative terminal of power supply the tape tether with width,  $w_b$ , (Fig. 2). Electrons collected by the boom cross supply to tape, where they leak at the rate of ion impacts plus secondary yield.  $I_e(\text{boom}) = I_i(\text{tape}) \times (1 + \gamma\alpha\varepsilon)$ , where  $\gamma\alpha\varepsilon \sim 0.15 \text{ e/kV}$  ion and the following equation is obtained:

$$eN_{\infty}L_b2R_b\sqrt{\frac{2e(1-\alpha)\varepsilon}{m_e}} = eN_{\infty}L_t\frac{2w_t}{\pi}\sqrt{\frac{2e\alpha\varepsilon}{m_i}} \times (1 + \gamma\alpha\varepsilon). \quad (1)$$

The plasma density will vary rapidly as the rocket ascends and descends, and the experiment will be conducted over six different voltages every 2 s for a total of 12 s: 0.5, 0.6, 0.7, 0.8, 0.9, and 1 kV. The maximum expected current will be 0.1 A.

During the next stage of the experiment, the negative terminal of the power supply will be switched to being connected to the hollow cathode, and the tape tether will be connected to the positive terminal (Fig. 3). Electrons collected by the tape tether will cross the supply and be ejected at the cathode. OML predicts the following:

$$I_e(\text{tape}) = eN_{\infty}L_t\frac{2w_t}{\pi}\sqrt{\frac{2e\varepsilon}{m_e}}. \quad (2)$$

The supply voltage,  $\varepsilon$ , sweeps across a range of values from 100 to 1,500 V during this phase. Each sweep will be obtained by either varying the voltage supply or across embedded resistors and will take 20 s.

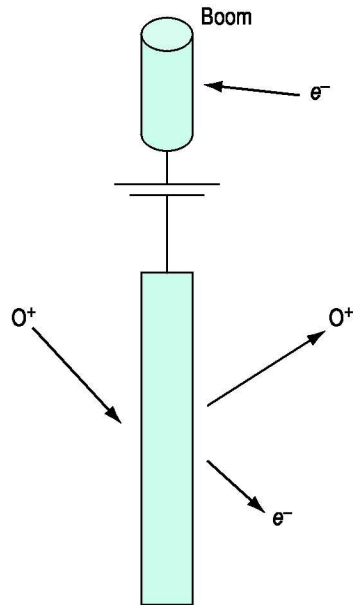

**Figure 2. Configuration for testing OML theory without the use of an active plasma contactor. The boom has a positive electrical bias.**

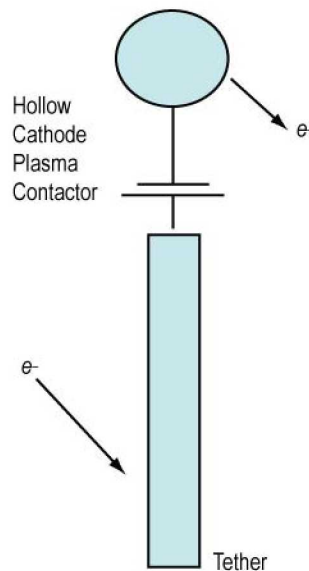
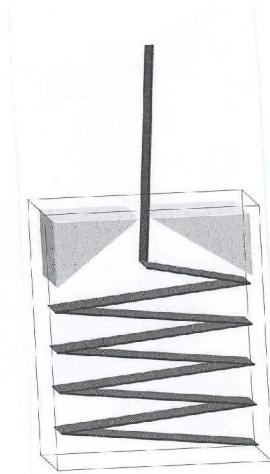

**Figure 3. Configuration for testing OML with the use of a plasma contactor.**

## EXPERIMENT HARDWARE

Instruments onboard the rocket will include Langmuir probes (for plasma diagnostics), a three-axis magnetometer (to measure the local magnetic field), accelerometers, and an ammeter (to measure the current at the onboard power supply).

The first objective of the experiment is to fully deploy the tape tether using a “new” deployment scheme that is actually derived from a very common technique used by firefighters in paying out very long firehoses. The tape will be folded and stacked into a box with an opening on one end—resembling a tissue box (Fig. 4). A spring will eject an endmass attached to the rocket by the tether. The tether will be deployed to its full 300-m length within 120 s. Three springs, with a total energy of 60 J, will kick off



**Figure 4. Concept drawing showing the T-Rex tape tether stored and being deployed from an open-ended box.**

the subsatellite with an initial velocity of 4 m/s. Braking is accomplished by applying a coating to the last several meters of the tether, increasing its deployment friction.

Colorado State University is contributing a fast-starting hollow cathode to the experiment. Hollow cathodes, which are devices that emit electron current into the plasma, have flown many times in space; but these heritage cathodes typically require both a lot of power and significant preignition conditioning before operation can commence. The Colorado State team has examined the cold start of the cathode and has found a way to reduce the conditioning time significantly by paying special attention to its storage environment.

#### ANTICIPATED RESULTS AND APPLICATIONS OF THE DATA

EDT thrusters work by virtue of the force a magnetic field exerts on a wire carrying an electrical current. This phenomenon was first observed by Ampere, one of the pioneers in the study of electromagnetic phenomena, around 180 years ago. The details of the force, which acts on any charged particle moving through a magnetic field (including the electrons moving in a current-carrying wire), were concisely expressed by Lorentz in 1895 in an equation that now bears his name. The force acts in a direction perpendicular to both the direction of current flow and the magnetic field vector. Electric motors make use of this force: a wire loop in a magnetic field is made to rotate by the torque the Lorentz force exerts on it due to an alternating current in the loop, timed so as to keep the torque acting in the same sense. The motion of the loop is transmitted to a shaft, thus providing work. Michael Faraday demonstrated the first simple electric motor in 1821.

Although the working principle of EDT thrusters is not new, its application to space transportation may be significant. In essence, an EDT thruster is just a clever way of getting an electrical current to flow in a long orbiting wire (the tether) so that the Earth's magnetic field will accelerate the wire, and consequently the payload attached to the wire. The direction of current flow in the tether, either toward or away from the Earth along the local vertical, determines whether the magnetic force will raise or lower the orbit.

The bias voltage of a vertically deployed metal tether, which results just from its orbital motion (assumed eastward) through Earth's magnetic field, is positive with respect to the ambient plasma at the top and negative at the bottom. This polarization is due to the action of the Lorentz force on the electrons in the tether. Thus, the "natural" current flow is the result of negative electrons being attracted to the upper end and then returned to the plasma at the lower end. The magnetic force in this case has a component opposite to the direction of motion, and thus leads to a lowering of the orbit and eventually to reentry. In this "generator" mode of operation, the Lorentz force serves both to drive the current and then to act on the current to decelerate the system. This operational mode was thoroughly verified to work in space by the TSS and PMG missions described above, but no measurements were made to quantify the resulting small orbital changes.

One of the most important features of tether thrusters is that they use renewable energy sources to drive the electrical current flow in either the orbit-raising or orbit-lowering modes. Sources inherent to Earth orbit are used. To raise the orbit, sunlight can be converted to the electrical energy required to drive the tether current. To lower the orbit, the orbital energy itself (supplied by the Earth-to-orbit launcher when it raises the system into orbit) is the energy source of the tether current via the action of the Lorentz force.

EDTs can be directly applied to a wide spectrum of uses in space. As a propulsion system, they include satellite deorbit, transfer of a satellite from one orbit to another, altitude maintenance for large spacecraft such as the International Space Station (ISS), and—since it works wherever there is a magnetic field and an ionosphere—planetary exploration missions.

Space is becoming increasingly cluttered with debris, from old satellites and rocket stages to bits of trash thrown overboard by early space travelers, and near-Earth space is becoming filled with collision hazards to current and future satellites. To mitigate the growth of this problem, a requirement that spacecraft deorbit themselves after completion of their mission is being considered by various governments. One method to do this would be to carry extra propellant so that the satellite can thrust to reentry. This requires a large mass of propellant, and every kilogram of propellant that must be carried reduces the weight available for payload. Moreover, it requires that the propulsion system must be functional after sitting in orbit for 10 years or more. EDTs provide a lower mass and potentially more reliable means of bringing old satellites out of orbit. A tether system could reside in a small package bolted to the satellite. When the end of the satellite's useful life is reached, a conducting tether several kilometers long would be deployed from the satellite, and the EDT propulsion orbit decay process would begin. The orbital decay process can be very rapid. Calculations indicate that a tether weighing as little as 2% of the satellite weight can bring a satellite out of some orbits in just a few weeks. (Compare that to *centuries* without any deorbit system.)

An EDT upper stage could be used as an orbit transfer vehicle (OTV) to move payloads within low-Earth orbit. The OTV would rendezvous with the payload and launch vehicle, grapple the payload, and maneuver it to a new orbital altitude or inclination *without the use of boost propellant*. The tug could then lower its orbit to rendezvous with the next payload and repeat the process. Conceivably, such a system could perform several orbital maneuvering assignments without resupply, making it relatively inexpensive to operate. However, due to the rapidly diminishing plasma density around the Earth, the tug would be limited to operation at altitudes of <2,300 km.

Outfitting the ISS with an electrodynamic reboost tether might eliminate the most critical and constraining dependency on Earth—propellant resupply. The ISS can supply its own power but not its own propellant.

A concept design for an EDT thruster capable of delivering 0.5–0.8 N of thrust to the ISS at a cost <10 kW of electrical power consists of a 10-km-long aluminum tether in the form of a thick ribbon (0.6 mm × 10 mm).<sup>6</sup> Despite its length, the tether would weigh only ≈200 kg. The tether reboost system would operate continuously and virtually eliminate the need for expensive resupply missions to keep the Station in orbit. Over its 10-year life, considerable cost savings might result. However, many questions, particularly those associated with crew safety, must be resolved before such a system can be placed on the Space Station. For example, a method for preventing recoil of a tether accidentally severed by a micrometeoroid orbital debris particle must be developed to mitigate the possibility of the tether wrapping itself around the Station or one of its critical components.

Perhaps the most exotic use of the technology would be to provide propulsion and power to spacecraft exploring the outer planets. The environment of the Jovian system has properties that are particularly favorable for use of an EDT. Specifically, the planet has a strong magnetic field and the mass of the planet dictates high orbital velocities, which when combined with the planet's rapid rotation rate, can produce very large relative velocities between the magnetic field and the spacecraft. In a circular orbit close to the planet, tether propulsive forces are found to be as high as 50 N, and power levels are as high as 1 MW.<sup>7</sup> With current spacecraft being extremely limited in power consumption due to their distance from the Sun (typically using <100 W), this level of available power could make available a whole new suite of science instruments such as high-power radar. However, the power levels are so high that power conversion, energy dissipation, and tether temperature become issues that must be addressed.

## SUMMARY AND CONCLUSION

The planned sounding rocket test of OML theory will be sufficient to validate bare wire tether anodes for future mission applications. In addition, a new type of tether deployment will be tested, possibly leading to a viable, survivable alternative to wire-type tethers used in past space missions.

## REFERENCES

1. Fujii, H. A.; Takegahara, H.; Oyama, K.; et al.: **A Proposed Bare-Tether Experiment On Board a Sounding Rocket**, *AIAA 2004-5718*, 2nd International Energy Conversion Engineering Conference, Providence, RI (August 16, 2004).
2. McCoy, J. E.; Grossi, M. D.; and Dobrowolny, M.: **Plasma Motor Generator (PMG) Flight Experiment Results**, Proceedings of the Fourth International Conference on Tethers in Space, Smithsonian Institution, Washington, DC, pp. 57–82 (1995).
3. Strim, B.; Pasta, M.; and Allais, E.: **TSS–1 Vs. TSS–1R**, Proceedings of the Fourth International Conference on Tethers in Space, Smithsonian Institution, Washington, DC, pp. 27–41 (1995).
4. Stone, N. H.; Wright, K.; Winningham, J. D.; et al.: **Identification of Charge Carriers in the Ionospheric Branch of the TSS-1 Tether Generated Current System**, Proceedings of the Fourth International Conference on Tethers in Space, Smithsonian Institution, Washington, DC, pp. 359–371 (1995).
5. Sanmartin, J. R.; Lorenzini, E. C.; Estes, R. D.; et al.: **Analysis of ProSEDS Test of Bare-Tether Collection**, 39th AIAA/ASME/SAE/ASEE Joint Propulsion Conference and Exhibit, Huntsville, AL (July 20–23, 2003).
6. Dankanich, J.; Bonometti, J.; Sorenson, K.; et al.: **Free Re-boost Electrodynamic Tether for the International Space Station**, *AIAA-2005-4545*, 41st AIAA/ASME/SAE/ASEE Joint Propulsion Conference and Exhibit, Tucson, AZ (July 10–13, 2005).
7. Gallagher, D. L.; Johnson, L.; Moore, J.; et al.: **Electrodynamic Tether Propulsion and Power Generation at Jupiter**, *NASA/TP—1998–208475*, Marshall Space Flight Center, AL, <<http://mtrs.msfc.nasa.gov/mtrs/98/tp208475.pdf>> (June 1998).

## GLOSSARY

EDT	electrodynamic tether
ISS	International Space Station
JAXA	Japan Aerospace Education Agency
OML	orbital-motion-limited
OTV	orbit transfer vehicle
PMG	plasma motor generator
T-Rex	Tether EXpeRiment
TSS	Tethered Satellite System





# Electrodynamic Propulsion System Tether Experiment (T-Rex)

**Les Johnson**

**NASA George C. Marshall Space Flight Center**

**H.A. Fujii**

**Tokyo Metropolitan Institute of Technology**

**J.R. Sanmartin**

**Universidad Politecnica de Madrid**





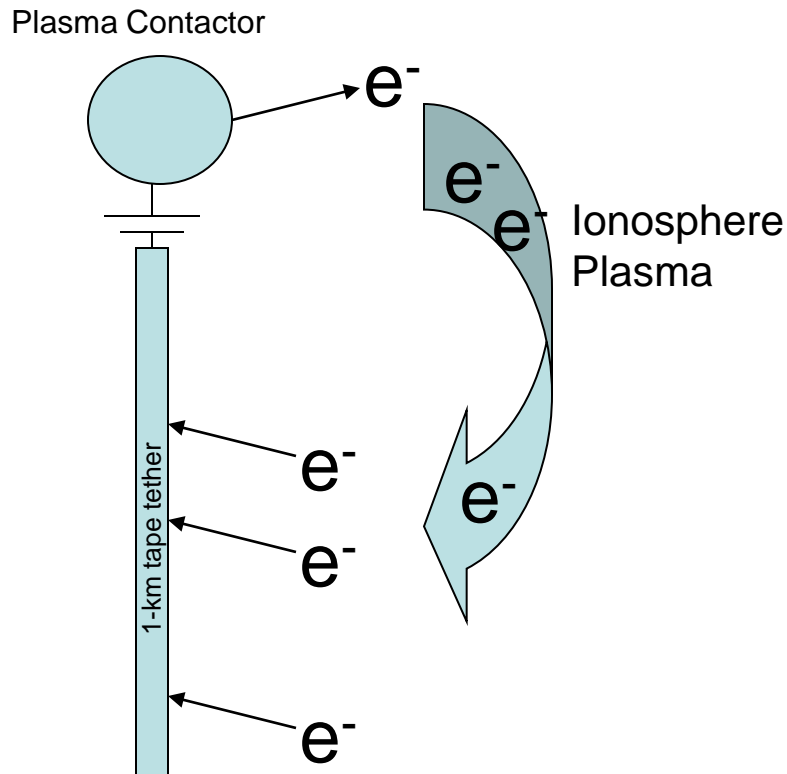

- **What is the experiment?**
  - Primary payload on an S-520 Sounding Rocket planned for ~~2009~~ 2010 launch
  - 300-meter conducting tape (tether) will be deployed to collect ionospheric current along its length
- **What are the objectives?**
  - Demonstrate the deployment of a “bare” electrodynamic tape tether in space
  - Test Orbital Motion Limited (OML) theory of bare tether current collection in space
- **Status: Waiting on new launch date**

Testing OML Theory an active plasma contactor. (The tether is biased positive.)



<u>Objective</u>	<u>Comment</u>
Fast deployment of a bare electrodynamic tether	Engineering: Deploy a bare, conductive tape tether in space
Fast ignition of a hollow cathode	Engineering: Ignite a hollow cathode in space for 180 seconds
Verification of electrodynamic tether operation in ionospheric plasma	Science: Eject electrons from an ignited hollow cathode and collect electrons by using a bare, electrodynamic tether
Verification of Orbit Motion Limited (OML) theory	Science: Measure electron collection by a positively-biased boom and a negatively-biased bare electrodynamic tether



# Mother / Daughter Payload Configuration

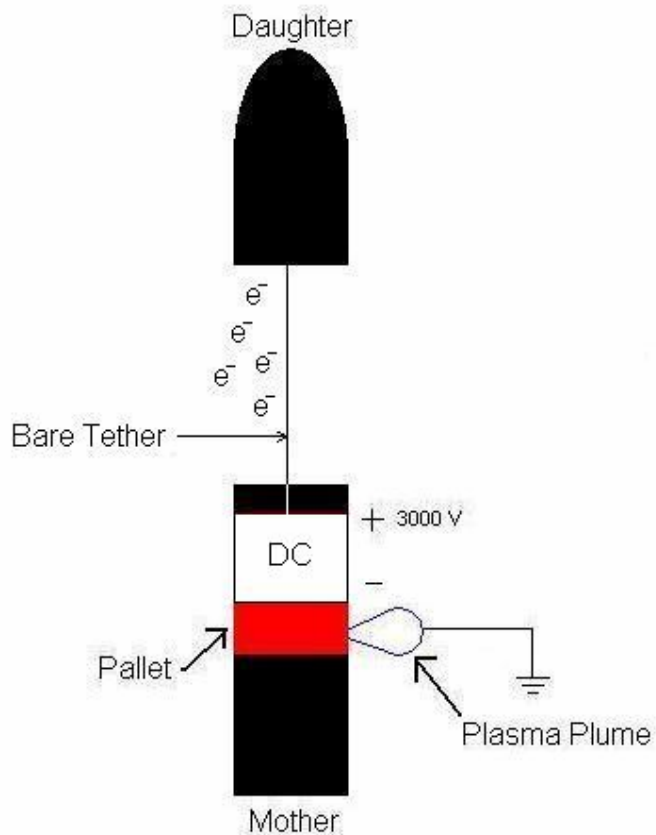



# • Mother / Daughter Payload Configuration (2)

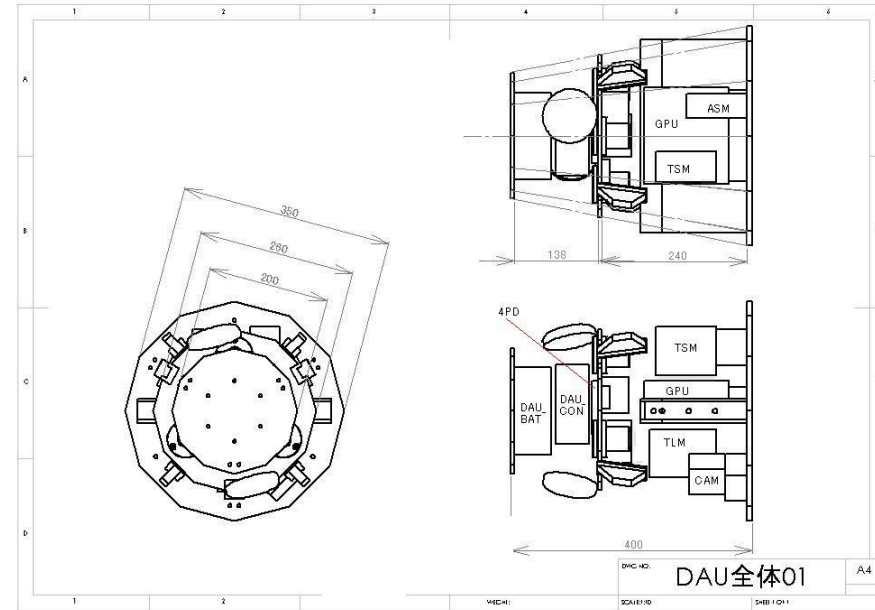
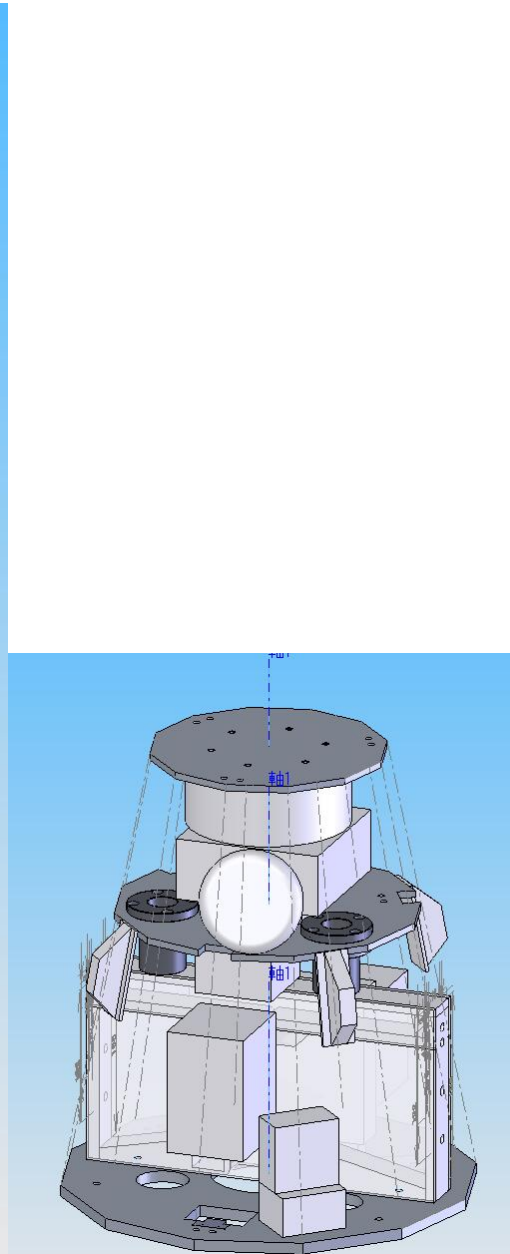
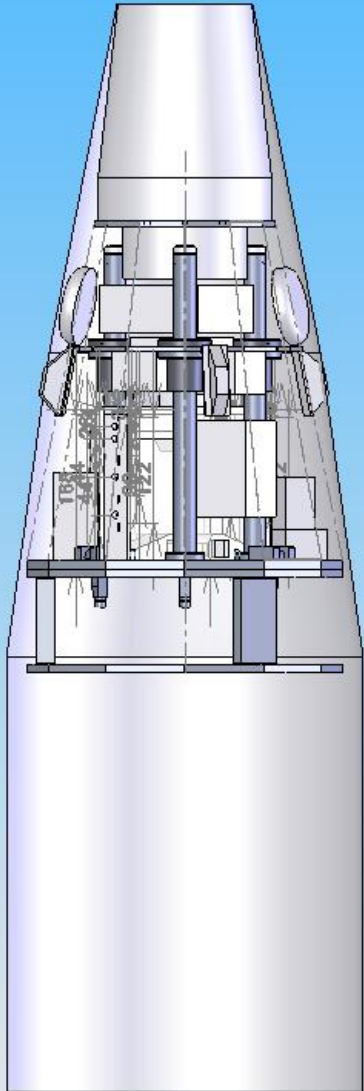

The daughter (upper part) and the mother (lower) modules



# Mission Profile



- **Nominal sounding rocket profile up to separation of payloads (350-km apogee; 4 - 5 minutes in space)**
- **Deployment of conductive boom**
- **Deployment of tape tether by ejection of upper payload**
- **Begin Experiment:**
  - Negative terminal of power supply is connected to the tape. The positive terminal is connected to the boom
  - Positive terminal of the power supply is connected to the tape. The negative terminal is connected to the hollow cathode.
- **Re-entry**

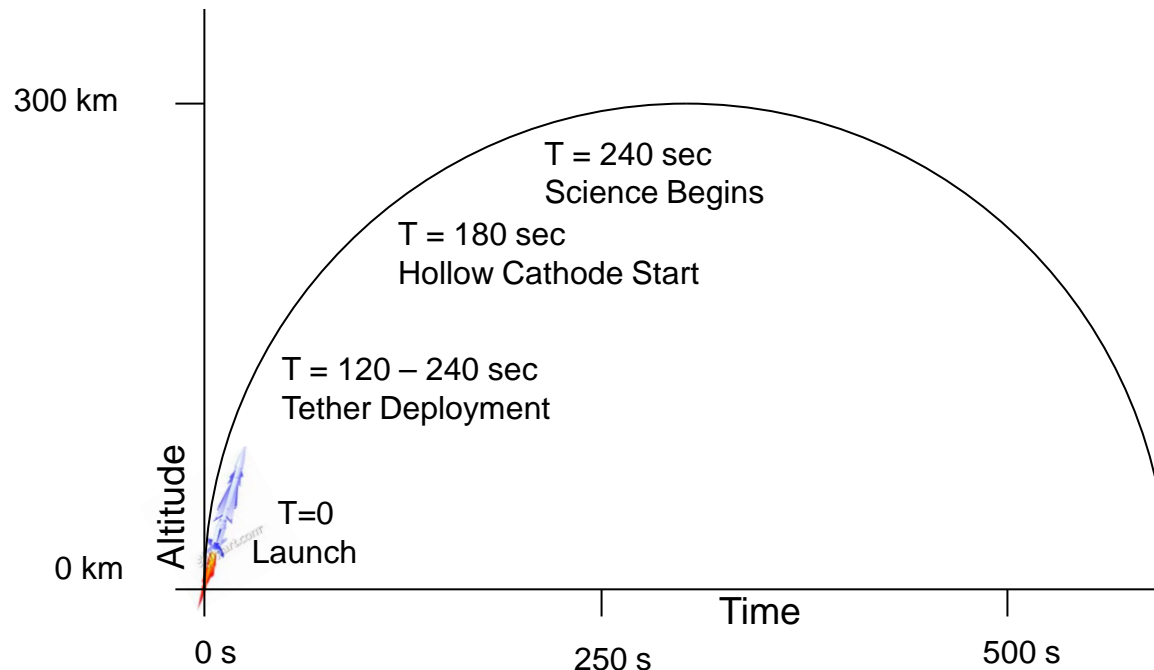

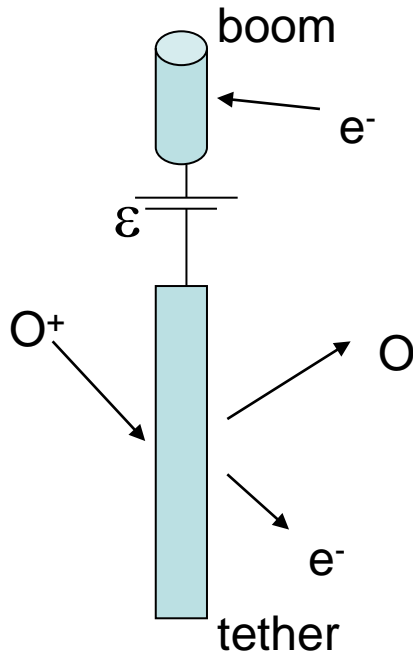

- The positive terminal of the power supply is connected to the conductive boom with length  $L_b$
- The negative terminal of the power supply is connected to the tape tether of width  $w_b$
- Electrons collected by the boom cross the supply to the tape, where they leak at the rate of ion impacts plus secondary yield
- As the plasma density varies during the flight, six different voltages will be used every 2 seconds for a total of 12 seconds
  - 0.5, 0.6, 0.7, 0.8, 0.9, 1.0 kV
  - The maximum current expected is 0.1 Ampere

The boom and tether are biased positive and negative, respectively.

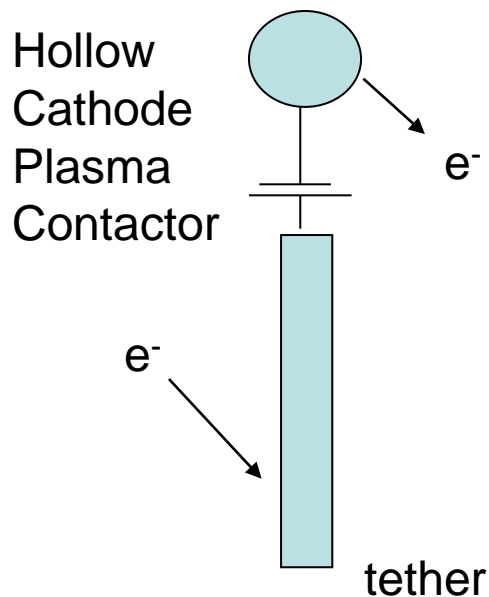

- The negative terminal of the power supply is connected to the hollow cathode
- The positive terminal of the power supply is connected to the tape tether
- Electrons collected by the tape tether cross the supply to be ejected by the hollow cathode
- The power supply sweeps across a range of values, from 100 V to 1500 V in 20 second intervals





# T-Rex Uses a Tape Tether



- Reinforced aluminum tape tether
- 300-meters long
- 25-mm wide
- 0.05 mm thick



- The tether experienced catastrophic arc discharge during partial vacuum testing



Pre-test sample

Post-test sample





# Tether Tested in Plasma Conditions

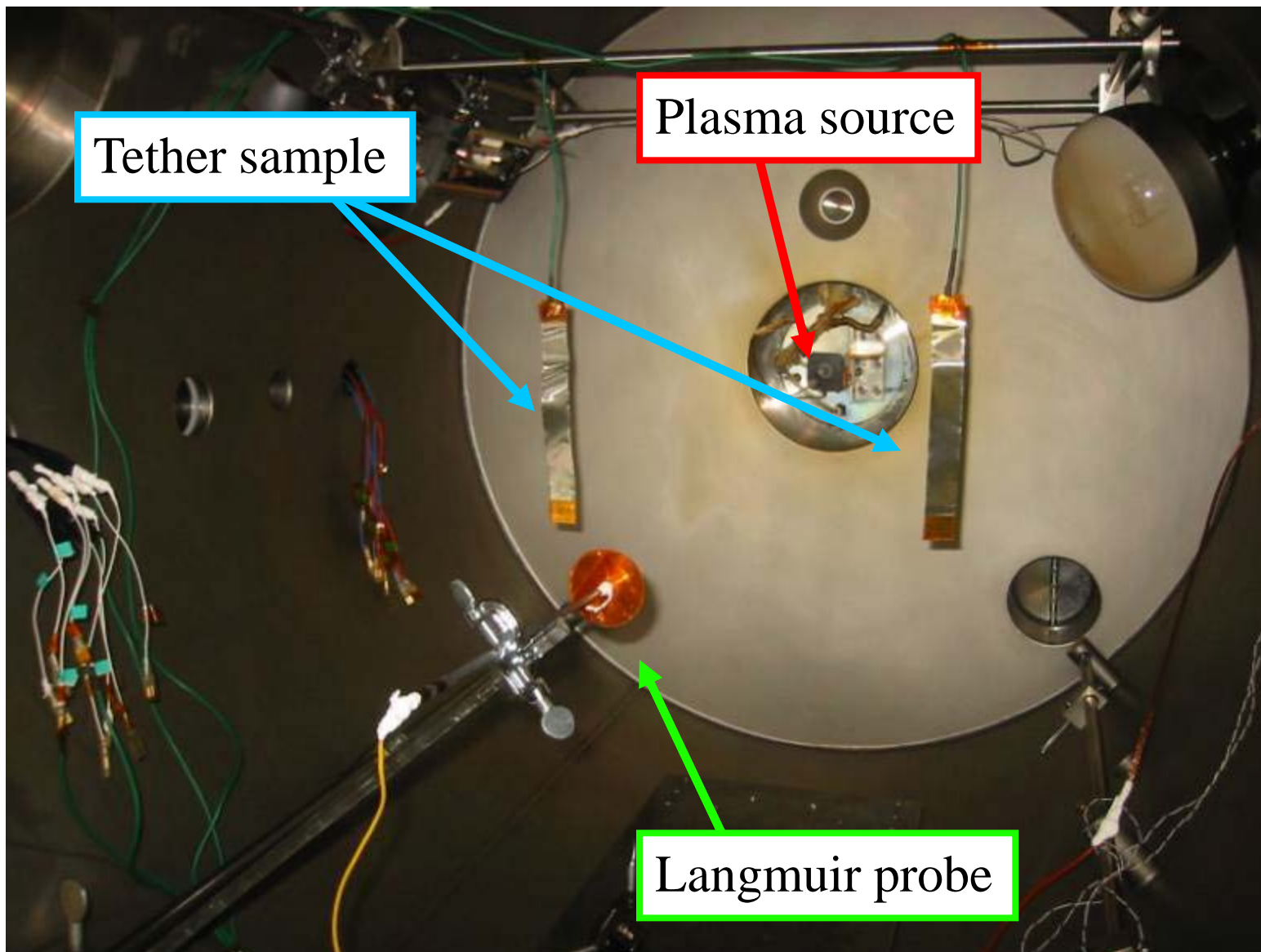



# T-Rex Required A New Deployer



- Spring ejects the endmass; onboard gas jet maintains deployment
- Tape tether is pulled from a box at 4 m/s
- Full deployment is expected at  $T = 120$  seconds
- Braking is accomplished by applying a coating to the last several meters of the tether to increase deployment friction

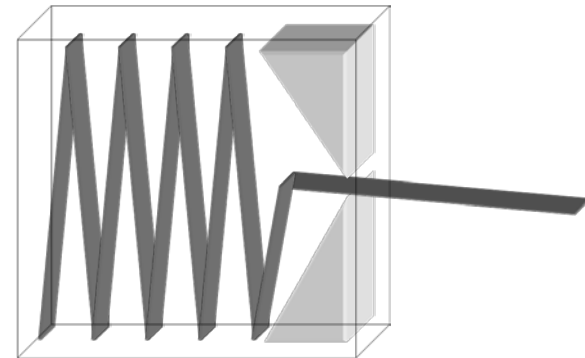

Note: NRL developed a tape tether deployer that was to be demonstrated by the ATEx experiment in 1999. The experiment was terminated before full deployment.



# Tether Deployment



- ED tether width 25mm, length 300m
- Daughter is ejected by a spring and tether is deployed. 20-kg Daughter is ejected with an initial velocity of 4m/s

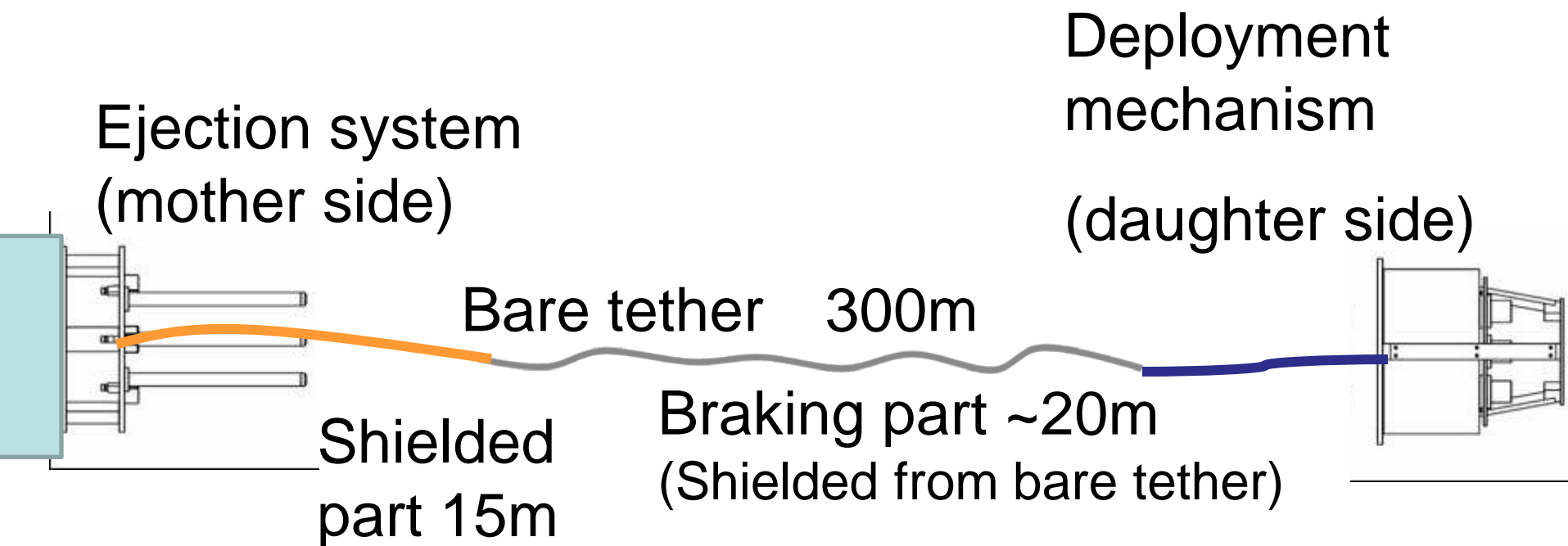

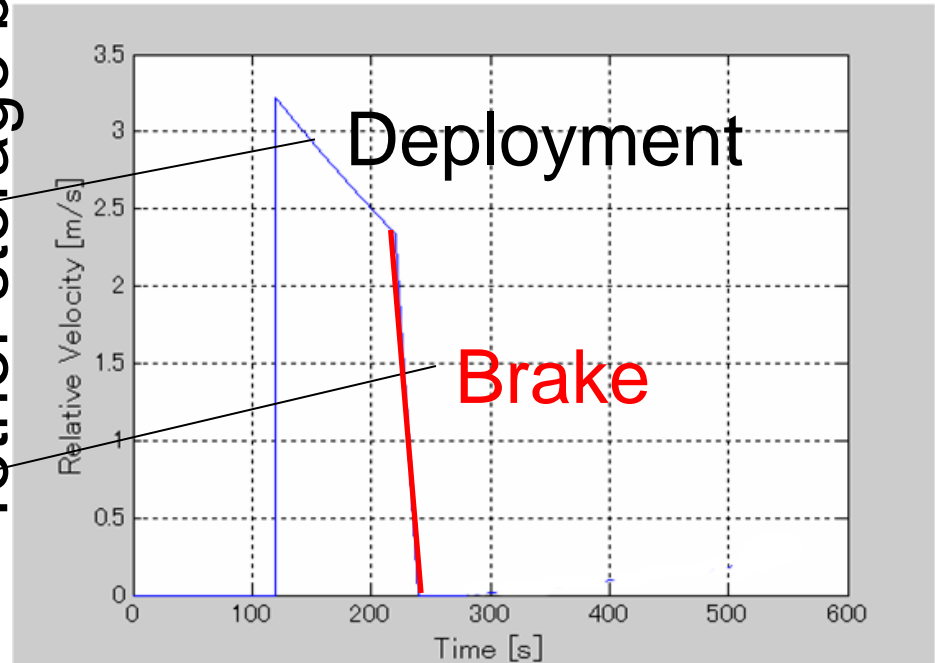
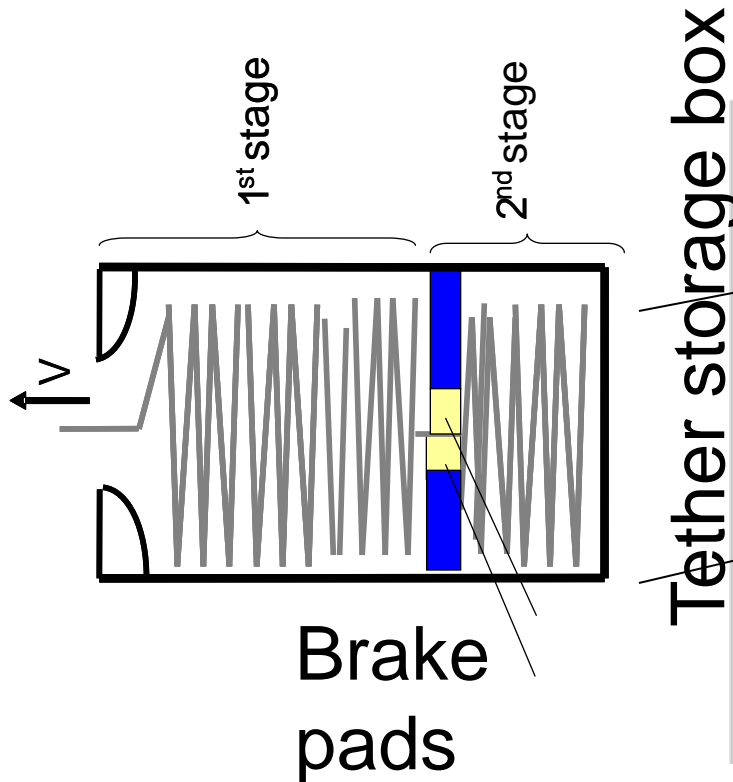

Time history of deployment velocity

Braking force ~ about 2 N



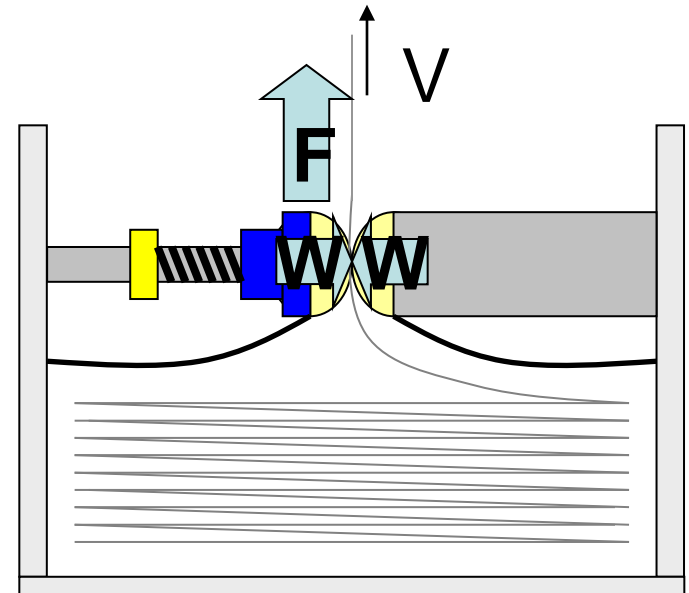
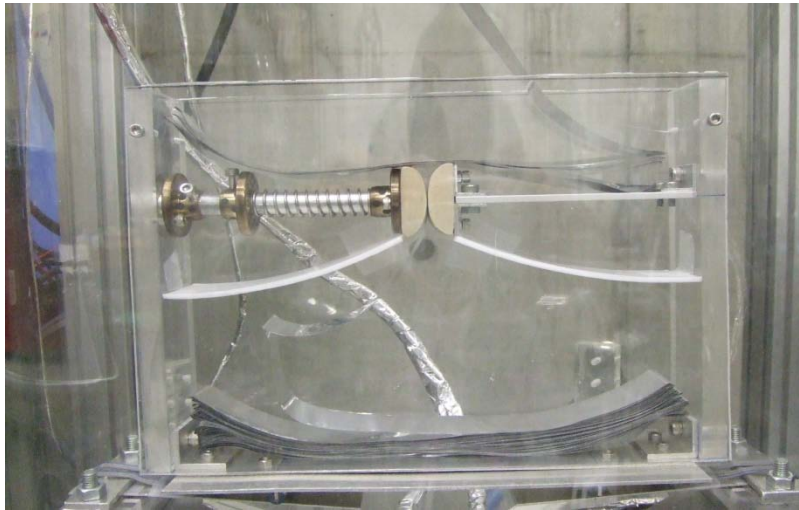

Brake control system





# Deployment demonstrated in parabolic flight

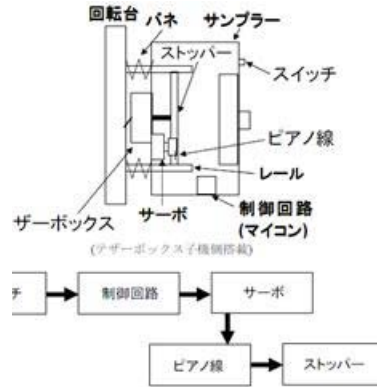
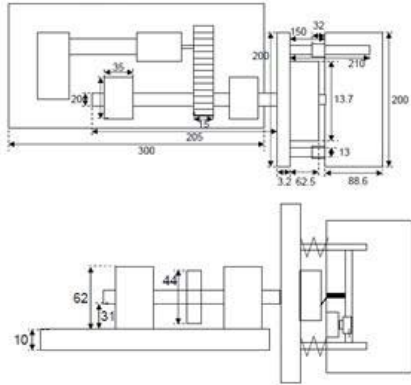

The tethered sample was deployed by spring force.



# Deployment demonstrated in parabolic flight, cont'd



## Deployed Tether

Reliability of tether deployer was demonstrated

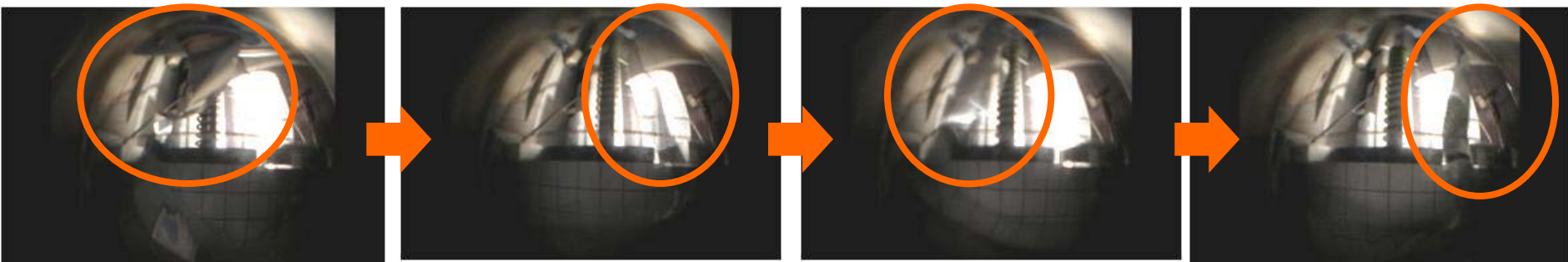

Fish eye Camera View (Tether storage box)

Sampler was launched by spring mechanism



Deployment Behavior



# T-Rex Required A New Plasma Contactor

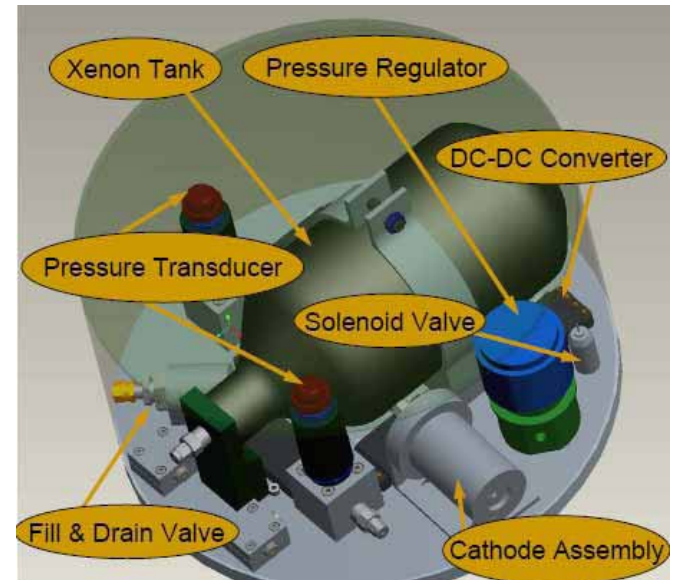
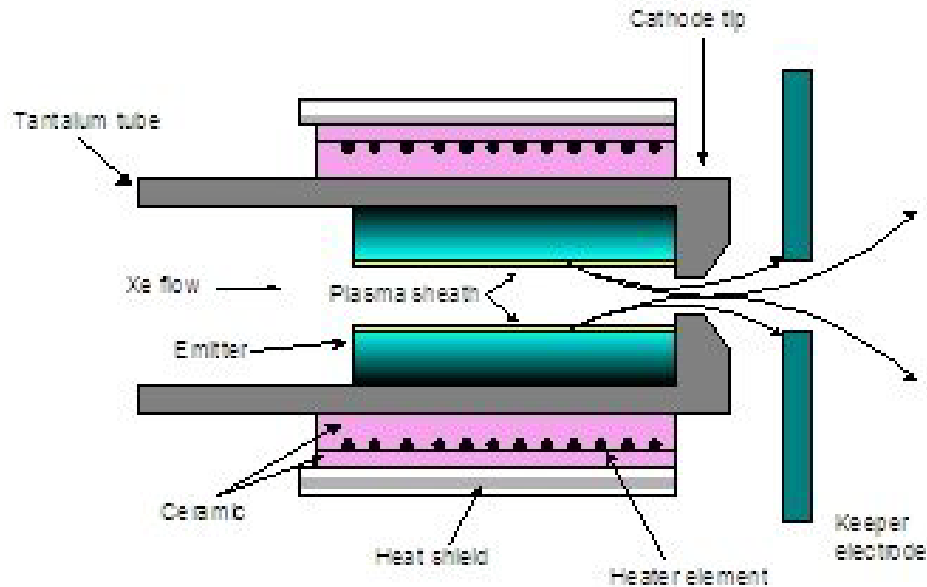

Plasma contactor subsystem layout.

Note: The hollow cathode plasma contactor developed for the ProSEDS experiment cannot be used due to its power and conditioning requirements.

The boom is inflatable with diameter 36mm and 4m in length

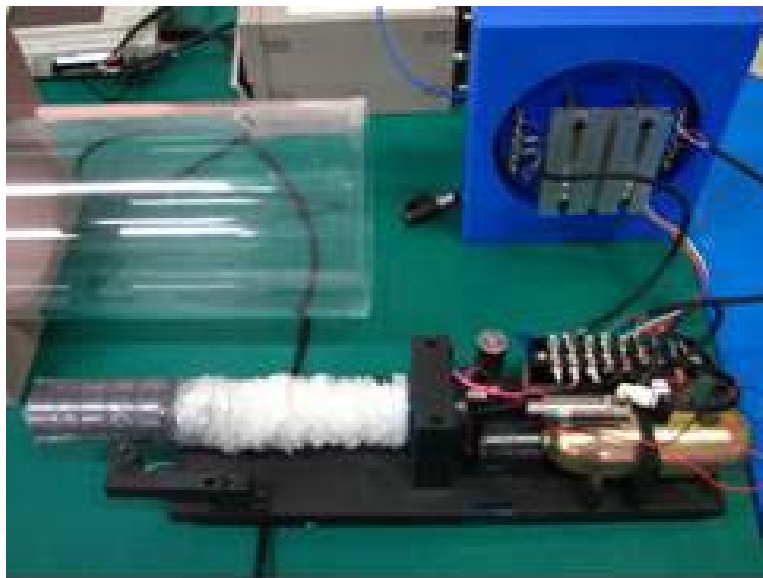

The boom is extended by gas (nitrogen) supplied from the system shown in the left.



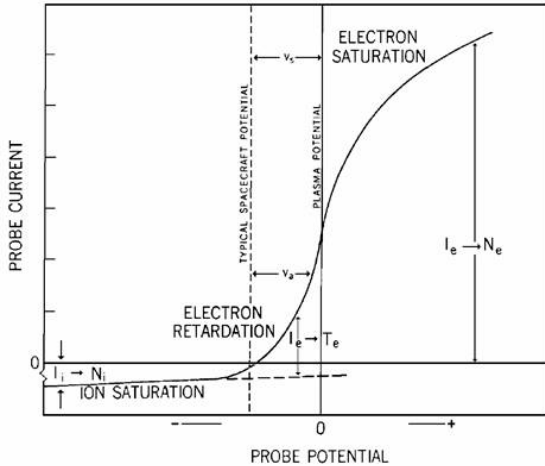

Sample Langmuir Probe data

- **Langmuir Probes:** plasma diagnostics (electron temperature, density and plasma potential)
- **3-Axis Magnetometer:** measurement of local magnetic field
- **Accelerometers:** engineering data
- **Ammeter:** measures the current at the onboard power supply

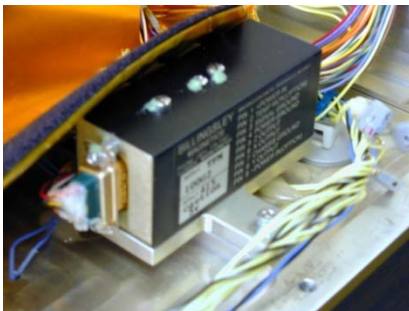

ProSEDS endmass' magnetometer

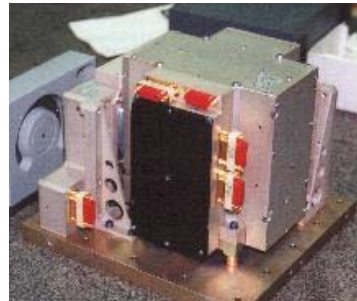

Spacecraft accelerometer

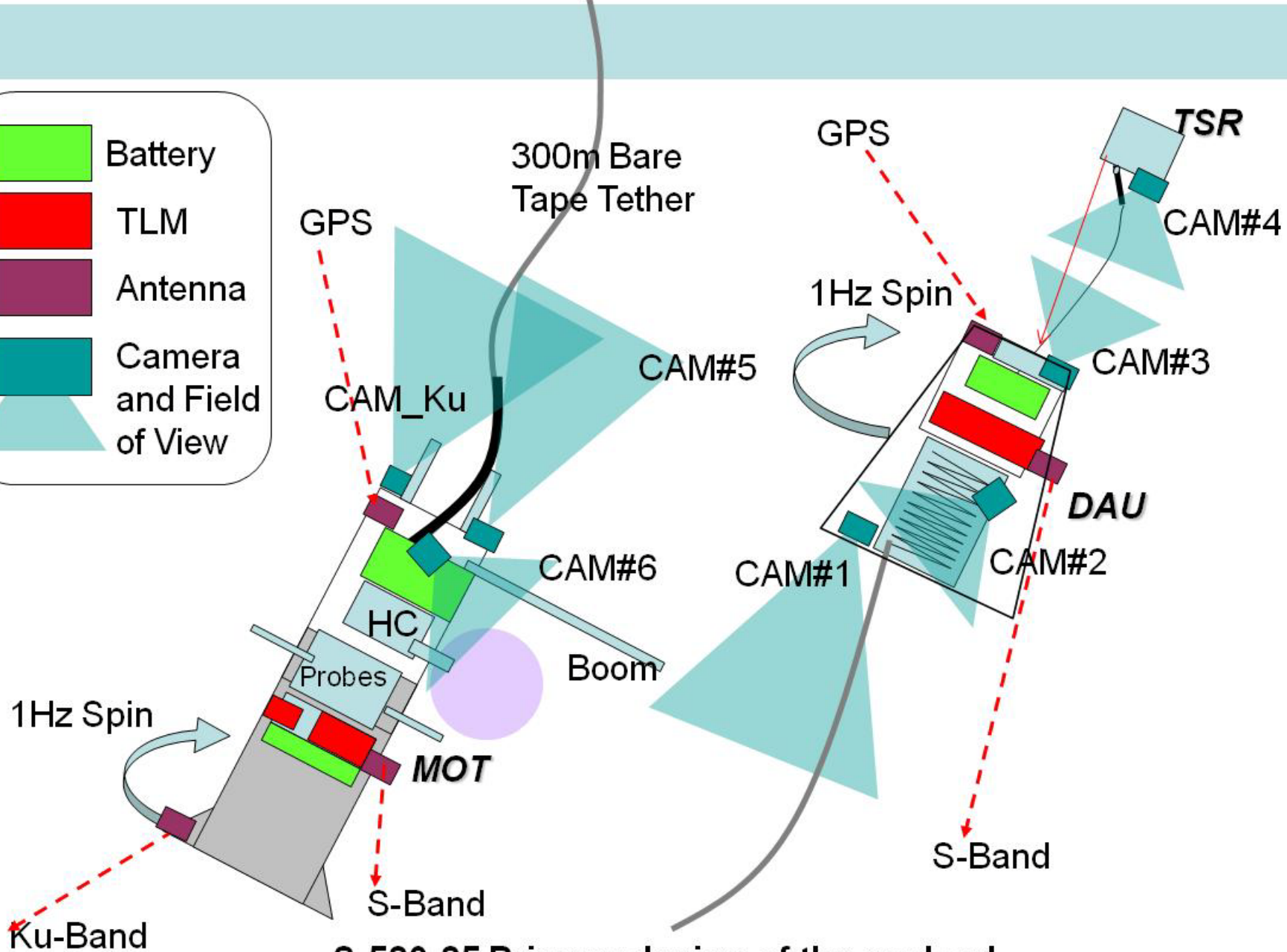
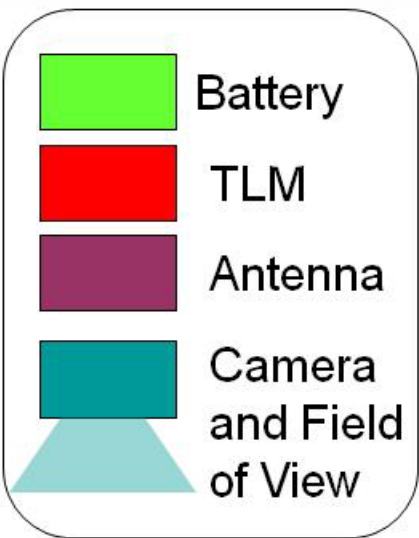

**S-520-25 Primary design of the payload**



# Potential Electrodynamic Tether Applications



- **ED tether thrust has multiple mission applications**
  - Satellite deorbit at end-of-life (to mitigate orbital debris)
  - Reboost of The International Space Station (nobody listened when this was first proposed as a “risk mitigation” 10 years ago...)
  - Propellantless, reusable Orbit Transfer Vehicles
  - Propulsion and power generation for future Jovian missions (up to 1 MW possible)
- **ED tether propulsion is required to implement Momentum eXchange Electrodynamic Reboost (MXER) tether systems for LEO-to-GEO (and beyond) orbit transfer.**

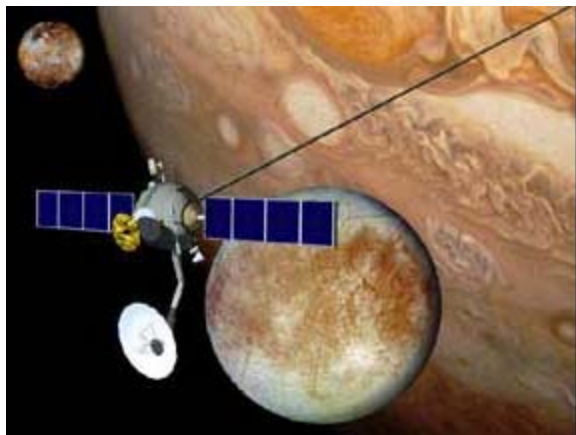





# The Team



Les  
Johnson

Juan  
Sanmartin

Hiro  
Fujii



The full team – including students