



### ⚙️ Mechanism for Particle Transport and Size Sorting via Low-Frequency Vibrations

**This technology would be useful for applications requiring sample handling.**

*NASA's Jet Propulsion Laboratory, Pasadena, California*

There is a need for effective sample handling tools to deliver and sort particles for analytical instruments that are planned for use in future NASA missions. Specifically, a need exists for a compact mechanism that allows transporting and sieving particle sizes of powdered cuttings and soil grains that may be acquired by sampling tools such as a robotic scoop or drill. The required tool needs to be low mass and compact to operate from such platforms as a lander or rover. This technology also would be applicable to sample handling when transporting samples to analyzers and sorting particles by size.

A metal bar or plate with a linear array of asymmetric grooves has been designed to be shaken at low frequency by a voice coil, or linear actuator, mechanism which induces the particles to jump from one groove to the next. Larger particles with diameters greater than the groove depth were shown to move quicker, while particles with a diameter that is less than the groove depth were found to move slower, thus creating a sorting by size. Using this asymmetry in particle motion with particle size, it is shown that both the movement of unconsolidated particles along the slide provided both transportation and sorting mechanisms.

The initial motion of the plate was created by a rotary motor linked to create symmetric vibrations. The figure shows a graphic illustration of this system. The rotary motion can be used to sample unconsolidated material from a platform. A ro-

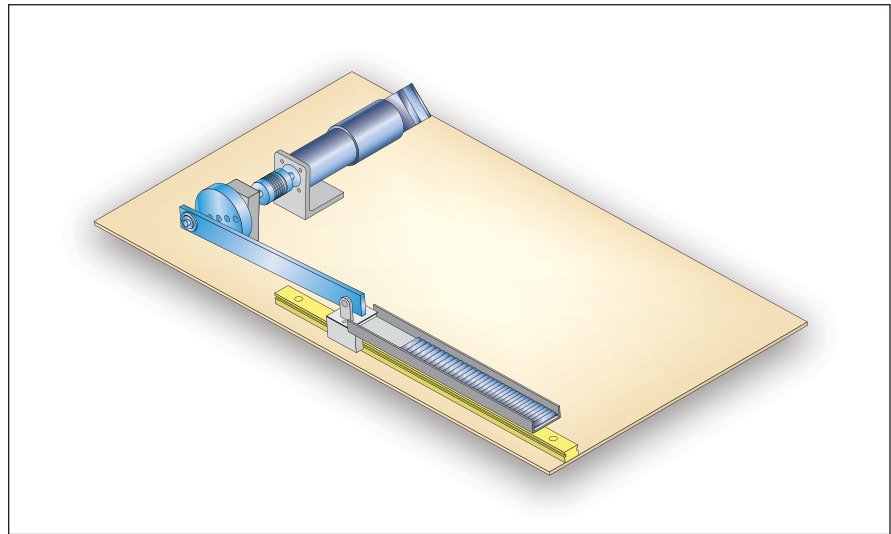

A Schematic View of the System using a rotary motor and a slide with asymmetric grooves.

tary motor causes linear oscillatory motion in the rod through a linkage, and causes particles in the grooves to move to higher-level grooves by being thrown from a lower groove. The linear actuation also could be developed with a voice coil actuator or any other linear motor. The use of asymmetric teeth increases the likelihood of a forward transfer of particles, and in each jump, the particles climb the toothlike steps. Introducing elliptical oscillations increases the efficiency of transfer by giving the sample movement vector normal to the slide axis.

An option to this design includes sieves to allow gauging of particle di-

mension. A distribution of particles is transported to the end of the groove rod. When particles enter a sieve with smaller holes, the excitation shakes them through the sieve. The excitation frequency is then increased, and the differentiated sample is then moved to the next larger size sieve where the process is repeated until all particles are sieved.

*This work was done by Stewart Sherrit, James S. Scott, Yoseph Bar-Cohen, Mircea Badescu, and Xiaoqi Bao of Caltech for NASA's Jet Propulsion Laboratory. Further information is contained in a TSP (see page 1). NPO-46334*

### ⚙️ Compact, Lightweight Electromagnetic Pump for Liquid Metal

**Overlapping thermal and magnetic issues are considered in this design increase efficiency.**

*Marshall Space Flight Center, Alabama*

A proposed direct-current electromagnetic pump for circulating a molten alkali metal alloy would be smaller and lighter and would demand less input power, relative to currently available

pumps of this type. (Molten alkali metals are used as heat-transfer fluids in high-temperature stages of some nuclear reactors.) The principle of operation of this or any such pump involves exploita-

tion of the electrical conductivity of the molten metal: An electric current is made to pass through the liquid metal along an axis perpendicular to the longitudinal axis of the flow channel, and a

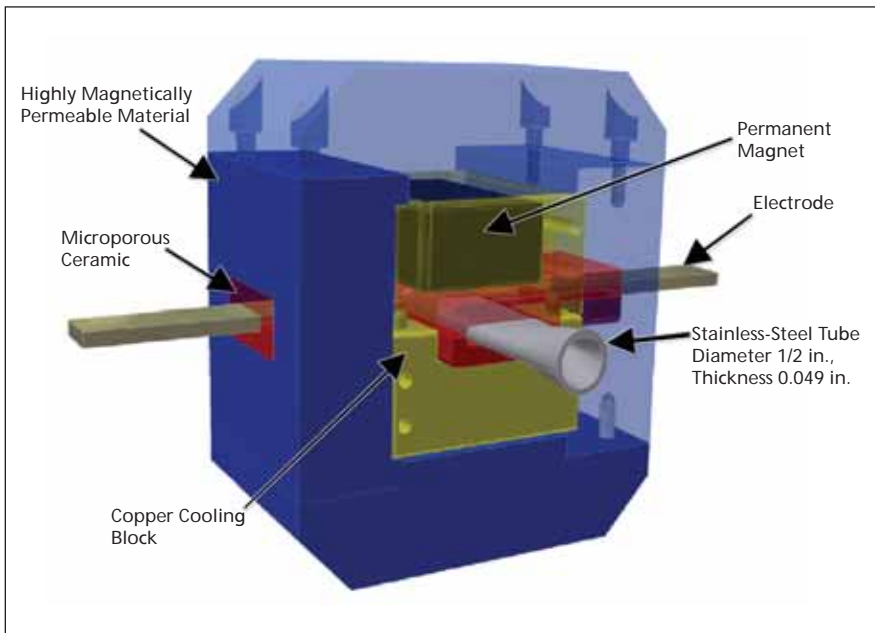

This Direct-Current Electromagnetic Pump is designed to develop a pressure of 5 psi (34 kPa) and a mass flow rate of 56 g/s when driven by an input current between 50 and 100 ADC (corresponding to an input potential of about 1 VDC). The pumped fluid would be a sodium-potassium eutectic at a temperature of about 650 °C.

magnetic field perpendicular to both the longitudinal axis and the electric current is superimposed on the flow-channel region containing the electric current. The interaction between the electric current and the magnetic field produces the pumping force along the longitudinal axis. The advantages of the proposed pump over other such pumps would accrue from design features that address overlapping thermal and magnetic issues.

Under the anticipated operating conditions, the molten alkali metal — a eutectic mixture of sodium and potassium — would be heated to a temperature of about 650 °C. To maximize the effectiveness of the pump while minimizing the electric current (and thus the power) needed for pumping at a given

rate, it is necessary to maximize the magnetic field across the flow channel. In order to do this, it would be desirable to use rare-earth (specifically, neodymium or samarium-cobalt) permanent magnets to apply the magnetic field and to place the magnets as close as possible to the flow channel. Because such magnets become demagnetized at temperatures around 130 or 350 °C, respectively, it becomes necessary to protect them against conduction and radiation of heat from the flow channel. In some other pumps of this type, the thermal-protection problem is solved by placing the magnets farther from the channel and then increasing the electric current needed to obtain the required pumping capacity. In still other pumps of this type, massive amounts of

convection cooling are used to prevent overheating of the magnets.

In the proposed pump, the liquid metal flow channel would be defined by a round stainless-steel tube that would be flattened to a nearly rectangular cross section in the region where the magnets were to be placed (see figure). Two permanent magnets would be placed on opposing sides of the channel, separated from the flat tube faces by thermal-insulation material consisting of a microporous ceramic having extremely low thermal conductivity. To remove the small amount of heat conducted through the ceramic, copper blocks housing the magnets are connected to a water-circulation cooling system. These blocks would be in direct thermal contact with each magnet, providing an isothermal heat sink to maintain the temperature below a required level. To maximize the magnetic flux density in the channel, the part of the magnetic circuit outside the channel would be completed with ferromagnetic material having a magnetic permeability and a magnetic-saturation threshold greater than those of simple iron.

Thick electrodes would conduct the applied electric current to the tube walls, and the current would be conducted through the tube walls to the liquid metal in the channel. A portion of the current would be conducted around the channel through the tube walls; this portion would not be available for generating pumping force. Hence, unavoidably, some power would be lost in heating of the tube walls.

*This work was done by Thomas Godfrey and Kurt Polzin of Marshall Space Flight Center. For further information, contact Sammy Nabors, MSFC Commercialization Assistance Lead, at sammy.a.nabors@nasa.gov. Refer to MFS-32597-1.*

## ⚙️ Progress in Development of the Axel Rovers

Robots like these could be used to search for victims of disasters.

*NASA's Jet Propulsion Laboratory, Pasadena, California*

Progress has been made in the development of a family of robotic land vehicles having modular and minimalist design features chosen to impart a combination of robustness, reliability, and versatility. These vehicles at earlier stages of development were described in two previous *NASA Tech Briefs* arti-

cles: "Reconfigurable Exploratory Robotic Vehicles" (NPO-20944), Vol. 25, No. 7 (July 2001), page 56; and "More About Reconfigurable Exploratory Robotic Vehicles" (NPO-30890), Vol. 33, No. 8 (August 2009), page 40. Conceived for use in exploration of the surfaces of Mars and other remote

planets, these vehicles could also be adapted to terrestrial applications, including exploration of volcanic craters or other hostile terrain, military reconnaissance, inspection of hazardous sites, and searching for victims of earthquakes, landslides, avalanches, or mining accidents. In addition, simpli-