

Mars Earth Return Vehicle (MERV) Propulsion Options

Steven R. Oleson,¹ Melissa L. McGuire,² Laura Burke,³ James Fincannon,⁴
Joe Warner,⁵ Glenn Williams,⁶ and Thomas Parkey⁷
NASA Glenn Research Center, Cleveland, Ohio 44135

Tony Colozza,⁸ Jim Fittje,⁹ Mike Martini,¹⁰ and Tom Packard¹¹
Analex Corporation, Cleveland, Ohio 44135

Joseph Hemminger¹²
N&R Engineering, Cleveland, Ohio 44135

John Gyekenyesi¹³
ASRC Engineering, Cleveland, Ohio 44135

The COMPASS Team was tasked with the design of a Mars Sample Return Vehicle. The current Mars sample return mission is a joint National Aeronautics and Space Administration (NASA) and European Space Agency (ESA) mission, with ESA contributing the launch vehicle for the Mars Sample Return Vehicle. The COMPASS Team ran a series of design trades for this Mars sample return vehicle. Four design options were investigated: Chemical Return /solar electric propulsion (SEP) stage outbound, all-SEP, all chemical and chemical with aerobraking. The all-SEP and Chemical with aerobraking were deemed the best choices for comparison. SEP can eliminate both the Earth flyby and the aerobraking maneuver (both considered high risk by the Mars Sample Return Project) required by the chemical propulsion option but also require long low thrust spiral times. However this is offset somewhat by the chemical/aerobrake missions use of an Earth flyby and aerobraking which also take many months. Cost and risk analyses are used to further differentiate the all-SEP and Chemical/Aerobrake options.

¹COMPASS Lead, DSB0, 21000 Brookpark Road, and AIAA Senior Member.

²COMPASS Integration Lead, DSB0, 21000 Brookpark Road, non-member.

³Mission Designer, DSB0, 21000 Brookpark Road, and Non-Member.

⁴Electrical Engineer, Power Systems, 21000 Brookpark Road, and Non-Member.

⁵Electrical Engineer, Communications Branch, 21000 Brookpark Road, and Non-Member.

⁶Electronics Engineer, Avionics Branch, 21000 Brookpark Road, and Non-Member.

⁷Aerospace Engineer, Cost Analysis, 21000 Brookpark Road, and AIAA Senior Member.

⁸Aerospace Engineer, Thermal Systems, 21000 Brookpark Road, and AIAA Senior Member.

⁹Aerospace Engineer, Propulsion Systems, 21000 Brookpark Road, and Non-Member.

¹⁰Aerospace Engineer, Mission Solutions Group, 21000 Brookpark Road, and AIAA Senior Member

¹¹Aerospace Engineer, Missions Solutions Group, 21000 Brookpark Road, and Non-Member.

¹²Reliability Engineer, Structures and Reliability, 21000 Brookpark Road, and AIAA Senior Member.

¹³Senior Structural Engineer, Structural Systems, 21000 Brookpark Road, and Non-Member.

I. Study Background and Assumptions

A. Introduction

THE purpose of this COMPASS design study was to compare and contrast propulsion options in the concept design of an orbiter/Earth Return Vehicle (ERV) S/C supporting a future Mars Sample Return (MSR) mission.

- Four propulsion options were specified for this study.
 - All Chemical propulsion system
 - Advanced chemical propulsion system with aerobraking
 - Higher thrust engines (reduced finite burn losses)
 - Pump-fed (reduced tank mass and volume, reliability)
 - SEP stage for outbound / on-board chemical for return (SEP stage dropped)
 - All SEP: Integrated solar electric propulsion stage (SEP stage NOT dropped)

During the COMPASS design session, the baseline all chemical propulsion system mission could not be closed. The amount of propellant necessary to perform the mission, even with staging, was more than the total wet mass that the Ariane launch vehicle could deliver. The chemical/SEP case, the all-SEP case and the advanced chemical propulsion with aerobraking at Mars allowed closure of the mission.

B. Assumptions

To facilitate the COMPASS teams' studies, the mission was divided into two segments: the outbound leg and the earth return leg. In most cases, a single vehicle was used for both legs, but this division allows the use of separate vehicles for each leg. For conceptual purposes, the outbound leg is the trip to Mars, Mars Orbit Insertion (MOI), and the retrieval of the sample case. The earth return leg entails the Trans-Earth Injection (TEI) burn for a ΔV of 2.14 km/s, a mid course correction, and includes all ΔV 's needed for ACS. The major trade studies were categorized as all chemical, all SEP and SEP/Chemical, where the SEP/Chemical used SEP on the outbound leg and chemical propulsion on the earth return leg. The outbound leg is performed by the *outbound stage* and the earth return leg is performed by the *earth return stage*.

To simplify the team's use of its MELs, the following assumptions were made. The two stages are assigned separate MELs. For the "all chemical" cases, the entire mission uses the Return Stage MEL. In the all SEP case, all propulsion related calculations are performed in the SEP stage's MEL. For the Chemical/SEP case, both the SEP MEL and Earth Return Stage MEL were used. This method of modeling requires the reader to understand that trade results must be interpreted over the entire mission and not to compare stage performances/data alone, which would result in an apples to oranges comparison.

The portion of the MERV called the *SEP stage MEL*, (used to Cases 1 and 2) captured the hardware line items necessary to build an SEP stage in the COMPASS design nomenclature MEL. For Case 1 and 2, this MEL designed the stage which was acting as the "outbound" stage and was responsible for performing the MOI burn. The portion of the MERV called the *Earth Return stage MEL* (used to Cases 1, 3 and 4) captured the hardware line items necessary to build a chemical stage in the COMPASS design nomenclature MEL. For Cases 3 (except for Case 3drop) and 4, the Return Stage MEL performed the entire mission: Outbound and Return mission burns. The "SEP stage" MEL was not used for Cases 3 and 4). The exception was Case 3 drop where the SEP Stage MEL was used to hold the portion of the chemical stage that was dropped once aerobrake orbit circularization was completed at Mars.

The portion of MERV mission designated *outbound stage* in the COMPASS design nomenclature was responsible for performing the following mission events:

- MOI ΔV : km/s depends on propulsion system used (electronic propulsion, chemical, aerobrake)
- Midcourse ΔV s
- ACS ΔV s

The portion of MERV mission designated *Earth return stage* in the COMPASS design nomenclature was responsible for performing the following mission events:

- TEI ΔV : 2.14 km/s
- Midcourse ΔV s
- ACS ΔV s

Table 1. Assumptions and Study Requirements

| Subsystem area | Assumptions and study requirements | Critical trades |
|----------------------------------|---|--|
| Top-Level | Capture a 5 kg sample container in low Mars orbit and return to Earth flyby where needed Provide communications relay for Lander and Mars Ascent Vehicle (MAV) Figures of Merit (FOMs): Returned sample mass, number, variety, science data, mission success probability, cost within discovery cap | SEP complete, SEP/CP, all chemical |
| System | Off-the-shelf (OTS) equipment where possible, TRL 6 cutoff 2011, 2015 launch year Mass growth per AIAA S-120-2006 (add growth to make system level 30%) | |
| Mission, Ops, GN&C | Integrated SEP system for outbound and return trajectory (Case 2), Chemical outbound, AB at Mars into low Mars orbit, chemical stage return (Case 4 family). | Moon order of visitation, SEP or chemical trajectories, individual sample returns (using chemical) |
| Launch Vehicle | Ariane V, chemical mission C ₃ 70.6 km ² /s ² , SEP mission C ₃ = 15 km ² /s ² Adapter: Launch Loads: Axial ± 1 g, Lateral ± 0.2g | Also consider Atlas V (4 m) with DPAF (share costs) and Falcon 9, Taurus 2. Option to start in Earth orbit with other launch vehicle |
| Propulsion | All SEP: Primary: 3+1 5 kW BPT-4000 Secondary: hydrazine, 1 lbf thrusters Chemical AB: primary: AMBR engine, 328 s Isp Secondary: hydrazine, 1 lbf thrusters | Trade: 1+1 7 kW ion, 2+1 3 kW HiVHAC, serial PPUs or cross-strapped |
| Power | 5000 W Power to Propulsion system (with 400 W housekeeping) Batteries for Mars and Moons eclipse, Sampling landing (~4 hr) | Array type, dual gimbals, cell type, battery options |
| Avionics/Comm. | Science run from central controller (and one spare), 2.5 GB data storage, 10 kb/s, single pointable high gain antenna (1 m) | Computer type, X- or Ka-band |
| Thermal & Environment | Body mounted radiator (main loads 350 Wth (power processing units (PPUs)), 100 W (transmitters)) Tank heaters Deep space radiation level @ 5 AU, micrometeoroid environment in Mars orbit | Trading |
| Mechanisms | Science arm/camera/sampler, two-axis 0.3 m antenna, thruster gimbals ±2°, landing legs, Sample Capsule (12 km/s entry), foam impact suppression | Landing legs, sample capsule, sampler arm |
| Structures | Primary: Hexagonal, <3 in. diameter, truss, Al-Li, secondary: 10% of stage components | Developing structure model, need Expendable Launch Vehicle (ELV) loads |
| Cost | Utilize MEL and iterate with subsystems for new DDT&E | Need new technology designs from subsystems |

The vehicle options trades in this design study were as follows:

Table 2. Assumptions and Study Trade Space Options

| Outbound stage options (Earth to Mars) | Return stage options (Return to Earth) | Subsystem and mission function location | |
|--|--|--|--|
| <ul style="list-style-type: none"> ▪ SEP (20+kW) ▪ All Chem (Biprop) | <ul style="list-style-type: none"> ▪ All Chem (Biprop) ▪ All Chem and Aerobrake ▪ Aerocapture | Return stage (ERV) <ul style="list-style-type: none"> ▪ C&DH ▪ Comm ▪ RCS ▪ EEV ▪ Cruise GNC | Outbound stage <ul style="list-style-type: none"> ▪ Rendezvous system ▪ Capture/transfer system |

C. Growth, Contingency and Margin Policy

Mass Growth: The COMPASS team uses the AIAA S-120-2006, *Standard Mass Properties Control for Space Systems* (Ref. 1). The percent growth factors are applied to each subsystem, after which the total system growth of the design is calculated. The COMPASS design team designed to a total growth of 30% or less. An additional growth is carried at the system level in order to add up to a total system growth of a maximal 30% limit on the dry mass of the system. Note that for designs requiring propellant, growth in propellant is either carried in the propellant calculation itself or in the ΔV used to calculate the propellant required to fly a mission.

D. Redundancy Assumptions

- 1) Single fault tolerant where possible in the design of the subsystems.
- 2) Exceptions
 - a. Propellant tanks
 - b. Radiators Mission Scenario Background

This study was based on the mission scenario outlined in the iMARS (written as both iMars, and IMARS in the referenced documentation) final report (Ref. 2). iMARS is a task force and the acronym stands for International Mars Architecture for Return of Samples. Recently, the iMARS team met in Washington to lay the foundation for an international collaboration to return samples from Mars. NASA hosted the meeting. iMARS meeting participants included representatives from more than half a dozen countries and NASA, the ESA, the Canadian Space Agency (CSA) and the Japan Aerospace Exploration Agency (JAXA). iMARS is a committee of the International Mars Exploration Working Group (IMEWG). The group was formed in 1993 to provide a forum for the international coordination of Mars exploration missions.

Mission Scenario: The goal of the iMars mission is to return samples from the surface of Mars, taken in diverse areas of the planet in order to provide Earth based scientists a wide range of data covering the various environments on the surface of Mars. The overall iMars mission architecture includes two flight elements: (1) the Lander and (2) the Orbiter. The Lander would be launched from Earth and perform a direct entry to the surface of Mars, collect the sample, and launch it back up to Mars orbit in a MAV. The Orbiter is launched from Earth, and would rendezvous with the sample in Mars orbit. Once it has docked with and acquired the Sample, it performs the TEI maneuver necessary to return the sample to the Earth.

COMPASS Task: For this design study, the COMPASS team was asked to design the second vehicle in this scenario: The Orbiter, which returns the Mars surface sample to the Earth. COMPASS has dubbed this orbiter for the purpose of this design session: MERV. The Orbiter portion of the mission is shown in Figure 1. This study focused on trading propulsion options for the MERV to improve mission success.

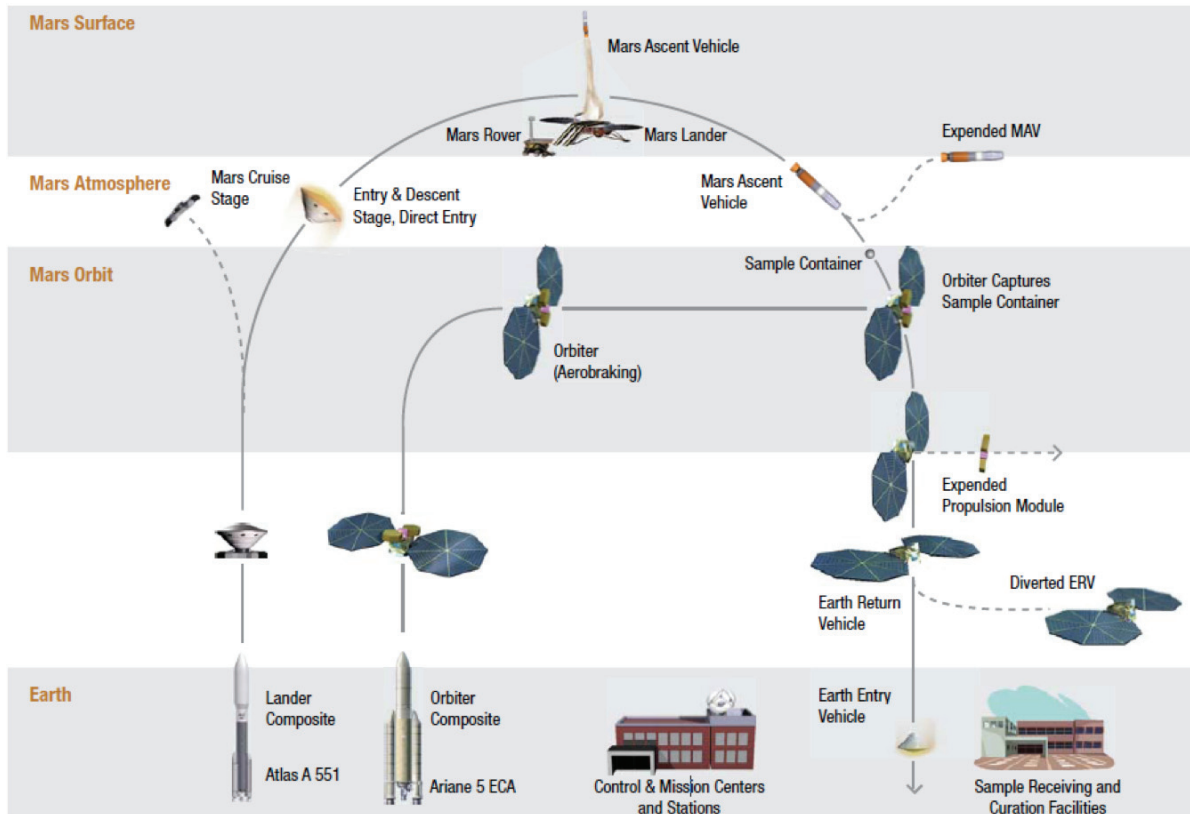

Figure 1. Mars Return Vehicle Mission Profile from iMars Studies

1. *Mission Analysis Assumptions*

For the Lander, which launches first and collects the sample, the following assumptions were given to this design study. For this study, the COMPASS designed vehicle was dubbed the MERV in order to avoid confusion with the Earth Return Vehicle (ERV) as mentioned in the iMars study report. The ERV is the concept placeholder in the Mars sample return mission architecture design. The following assumptions were used in the CONOPS and timeline of the MERV design study.

In order to correct any confusion, the following nomenclature is used in this study.

- **ERV**—iMars designation for the vehicle that will return the Mars sample to Earth (see Figure 1)
- **MERV**—The COMPASS designation for the orbiter portion of the iMars Mars Sample return mission as outlined in Section I.D

Mission Assumptions from the iMars mission scenario for this design were:

- Lander launched first, separately in 2020
- Orbiter launches second in 2022
 - MAV launches Orbiting Sample (OS) into 500 ± 100 km orbit, $\pm 0.2^\circ$ inclination
 - Launched from 45° latitude
 - Requires relay orbiter support (not from Orbiter/ERV)
- Sample recovered in low Mars orbit ~2024
 - Assume 3 months for rendezvous operations (April-May-June)
 - Return to Earth beginning July 21st
- Option to launch orbiter in 2024 (2022 bad opportunity)

2. *Low Thrust Mission Analysis Analytic Methods*

The low thrust trajectory design for SEP portion of this mission was optimized using the Mission Analysis Low-thrust Trajectory Optimization (MALTO) tool. Mission analysis was performed in an iterative fashion. An initial trajectory to the target was performed using MALTO to get the EP system propellant loading for the missions. With this propellant, the bottoms-up estimation of the vehicle mass was completed by the team. Once this bottoms-up mass was calculated, the trajectory was rerun in order to provide performance for at least that calculated total wet mass. The mission was iterated until the amount of mass pushed by the EP system was greater than or equal to the total wet mass of the vehicle.

For the all SEP case, the MALTO tool was used for the trajectory design and optimization. Several thrusters were traded including the NEXT, HiVHAC, and BPT-4000. The BPT-4000 is the baseline system because of its high thrust and therefore reduced mission time (especially in Mars' gravity well). The BPT-4000 is able to reduce the spiraling time enough to complete the sample collection and spiral back out from low Mars orbit to make the optimal return date. While some of the transfer phase has sufficient power to operate three thrusters simultaneously, some of the spiraling will be limited to only two thrusters at a time.

3. *Mission Analysis Event Timeline (Case 2—All SEP)*

The baseline mission (Case 2 all SEP) launches from Earth on June 27, 2022, with a mass of 3300 kg and a C_3 of $15.6 \text{ km}^2/\text{s}^2$. The system performs a thrust arc to raise aphelion and then has a long coast period to the final rendezvous thrust phase. After entering the Mars vicinity on July 5, 2023, the EP thrusters are used to spiral down to the 500 km altitude for another 6 months. The S/C then has three months of Mars operations and sample capture before starting the spiral out of Mars on April 5, 2024. The S/C spirals for 112 d before achieving escape energy on July 26, 2024. After escape there is only a thrust maneuver to target the Earth. The S/C then has a long coast period before the Earth entry which on August 15, 2025 with a constrained maximum entry V_∞ of 7 km/s.

- Lander launched first, separately in 2020
- Orbiter launches second in 2022
- Sample recovered in low Mars orbit ~2024
- Assume 3 months for Rendezvous operations (April-May-June)
- Return to Earth beginning July 21st
- SEP outbound time to capture orbit: 1 yr
- SEP Mars spiral time: 6 months
- SEP return time to Earth: 1.5 yr

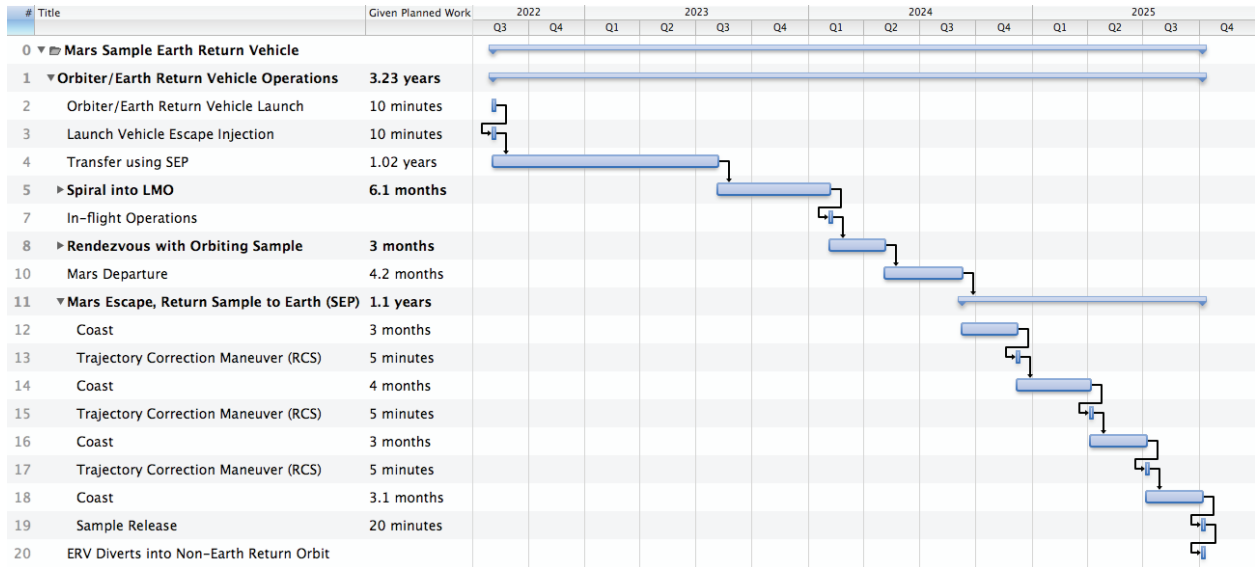

Figure 2. Case 2 All-SEP Trajectory Timeline—Earth Departure 2022

4. Mission Trajectory Details—Case 2 All SEP

Table 3. Case 2 All-SEP Trajectory Details

| EP mission analysis outputs | MERV Case2 |
|---|---|
| Parameter | Value |
| Mass, Xenon Total | 1736.2 kg |
| Mass, Xenon Useable | 1598.7 kg |
| Mass, Xenon Nav. and Trajectory Margin | 79.9 kg |
| Mass, Xenon Residuals | 57.6 kg |
| Mass, Xenon Nav. and Trajectory Margin | 79.9% |
| Mass, Xenon Residuals | 57.6% |
| Thruster | BPT-4000 |
| Quantity, Number of Thrusters Operating | 3 |
| Power, SA at 1 AU | 23.6 kW |
| Time, Transfer to Mars | 373 d |
| Time, Spiral to 500 km | 185 d |
| dV, 100 km change | 0.043 km/s |
| dV, Plane change | 0.012 km/s |
| Mass, Xenon for 100 km | 6.54 kg |
| Mass, Xenon plane change | 1.75 kg |
| Mass, Arrival at Mars | 2693.8 kg |
| Mass, Transfer to Mars Prop | 606.2 kg |
| Mass, Spiral to 500 km Prop | 350.9 kg |
| Date, Launch | June 27, 2022 |
| Date, Mars Arrival | July 5, 2023 |
| Date, End of Spiral | January 6, 2024 |
| Energy, C ₃ | 15.6025 km ² /s ² |
| Mass, Launch Mass | 3300 km/s |
| Launch Mass Margin | 10% |
| Mass, Launch Mass Margin | 366.7 kg |
| ELV performance Premargin | 1222.2 kg |

Figure 3 shows the trajectory from the Earth to Mars for the all-SEP case.

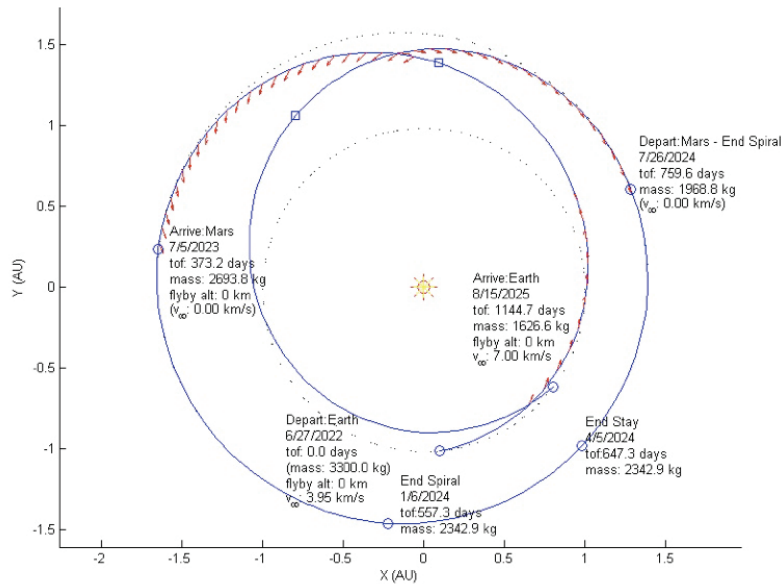

Figure 3. Case 2 All SEP Trajectory

5. Chemical Mission Analysis Analytic Methods

The chemical trajectory mission was optimized using Copernicus, a generalized trajectory design and optimization program. The chemical mission was analyzed in two separate parts, the outbound leg and the inbound leg. The outbound leg was modeled as an Earth to Mars transfer with a MOI maneuver. The inbound leg was modeled as a TEI and then coast to Earth. Both the outbound and inbound trajectories are type II trajectories. If the interplanetary trajectory carries the S/C less than 180° around the Sun, it's called a Type-I Trajectory. If the trajectory carries it 180° or more around the Sun, it's called a Type-II.

Gravity losses are significant when capturing into or escaping from Mars for vehicles without very high thrust. For this reason the MOI and TEI maneuvers were each split into two burn sequences such that an intermediate highly elliptical orbit is achieved prior to final orbit insertion. Splitting each of these maneuvers will reduce the effects of gravity loss, thus lowering the Delta-V required for MOI and TEI.

Optimization was performed on the outbound leg of the trajectory such that the launch energy as well as total MOI Delta-V were minimized. The burns during the MOI sequence were allowed to be split optimally by Copernicus, resulting in an approximately 96-hr intermediate elliptical orbit. This approach allowed for the Ariane V to deliver the largest mass possible while still minimizing the required MOI Delta-V. MOI was analyzed assuming an initial S/C mass at Mars of 4000 kg. Optimization was done on the inbound leg of the mission such that the total Delta-V for the TEI sequence was minimized. The intermediate orbit was constrained to be a 96-hr elliptical orbit in order to reduce the total time for the TEI maneuver. This mission analysis was done using the ideal ELV performance to Mars. The actual vehicle design will deduct 10% for margin on the ELV performance per COMPASS guidelines and use 3600 kg as the mass into which the final design must fit.

6. Thrust Losses—Insertion Delta V Versus Thrust

Initially two launch opportunities were analyzed for the chemical mission, 2022 and 2024. The MOI Delta-Vs was optimized using Copernicus for each opportunity. The results of this analysis are presented for 2022 in Figure 5, and for 2024 in Figure 6. These plots show the propulsive thrust versus Delta-V for the MOI 1 and MOI 2 maneuvers separately. Additionally, the 2022 opportunity provides the Delta-V curve for a chemical circularization following MOI 1 into a 96-hr orbit. The thrust for these data points were taken as multiples of the AMBR engine (thrust of 667 N). The MOI 1 Delta-V difference between a single AMBR case and a two AMBR Case is fairly significant, upwards of 200 m/s. This step rise in Delta-V can be attributed to the increased effects of gravity loss on lower thrust vehicles. It is because of this that two AMBR engines were baselined for the chemical mission.

The final selection of the baseline launch opportunity is discussed in Section I.D.1.

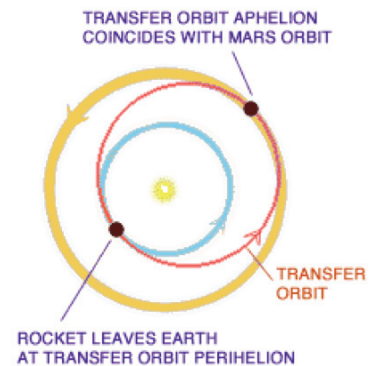

Figure 4. Low Energy Earth to Mars Transfer Trajectory

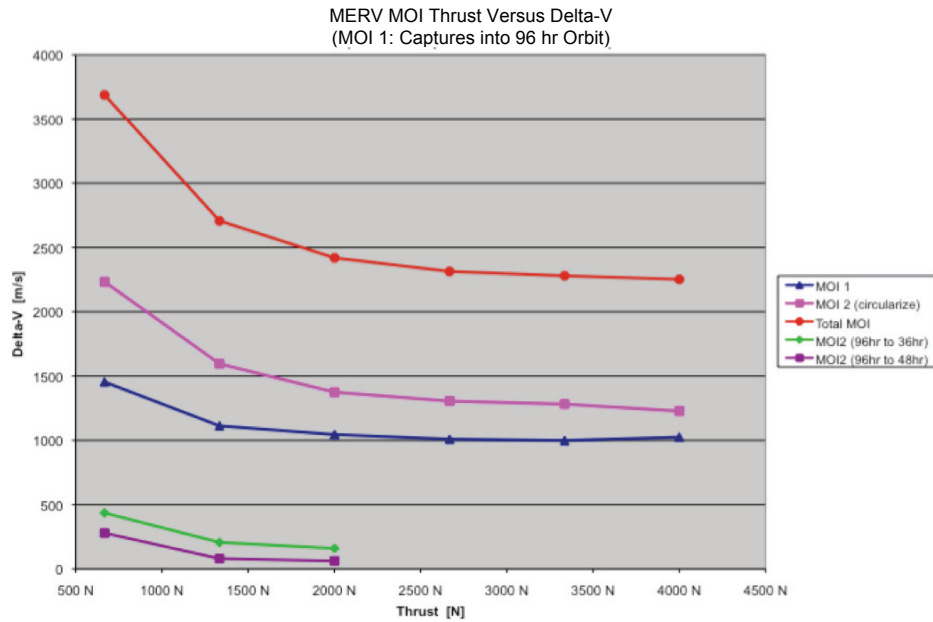

Figure 5. 2022 Opportunity: MERV Insertion Delta V Versus Propulsive Thrust for All-Chemical and Chemical-Aerobrake Options

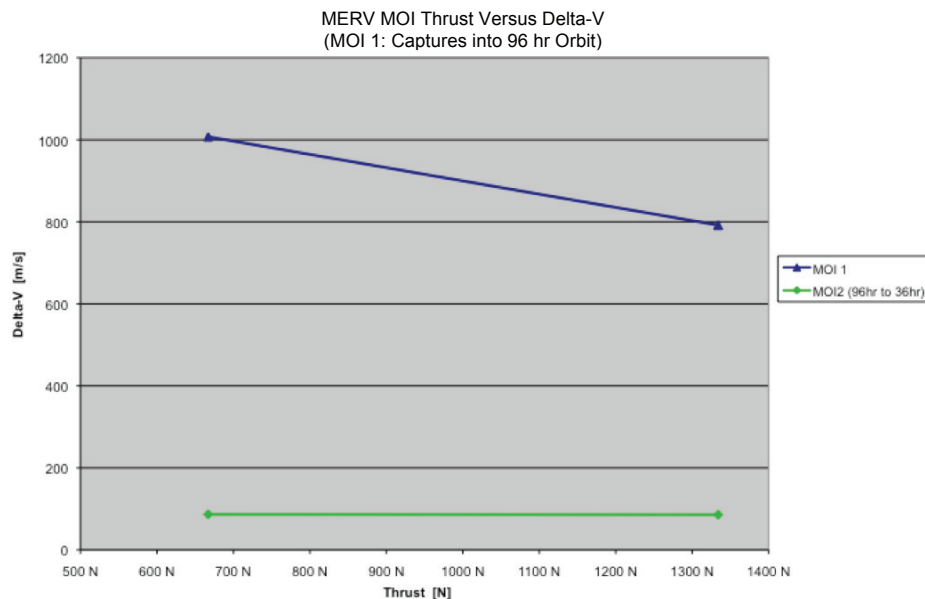

Figure 6. 2024 Opportunity: MERV Insertion Delta V Versus Propulsive Thrust for Chemical-Aerobrake Option

7. Mission Trajectory Details (Case 4—One AMBR)

All launch opportunities from 2018 through 2026 were evaluated for a potential two-week launch window. The Ariane V can launch to declinations from -2° to 2° without a performance penalty. A maneuver would be required to achieve declinations outside this range during launch. Additionally, delivered mass capability decreases with increasing launch energy (C_3) so low launch energy over the 2-week launch window is desirable. A summary of launch opportunities is provided in Table 4.

The 2024 opportunity was chosen as the baseline opportunity for this mission because it has the lowest launch energy over the launch windows while maintaining a launch declination within the -2° to 2° range. The energy (C_3) for the 2018 opportunity is the lowest in the launch years shown in Table 4 but is too early and is therefore outside of the scope of the launch years required for this mission.

The baseline chemical mission in 2024 departs from Earth October 2, 2024, and arrives at Mars after 330 d on August 28, 2025. At this time, the first Mars Orbit Insertion burn is performed to capture into a highly elliptical orbit

with a 500 km radius of perigee. Two-AMBR engines were used to perform this maneuver, resulting in a Delta-V for MOI 1 of 791 m/s and approximate burn time of 35 min. A second burn is then used to lower the apogee of the orbit such that the final orbit is a 36-hr elliptical orbit inclined at 45°. Two AMBR engines are used during this maneuver as well resulting in a Delta-V for MOI 2 of 86 m/s and a burn time of approximately 3.3 min. This 36-hr orbit is the starting point for the aerobraking maneuver.

Table 4. Launch Energy for Launch Opportunity

| Launch year | C ₃ (km ² /s ²) | Declination (°) |
|-------------|---|-----------------|
| 2018 | 8.5 to 11 | -2° |
| 2020 | 16 | 15° |
| 2022 | 14.75 to 15 | 2° |
| 2024 | 13 | 2° |
| 2026 | 13.5 to 14 | 2° |

The TEI chemical departure maneuver is initiated on August 5, 2026. To reduce the effects of gravity loss during departure, the TEI maneuver was split into two burns. The TEI 1 raises the S/C into a 96-hr elliptical orbit. TEI two injects the S/C into a hyperbolic orbit to return to Earth. The Delta-V for TEI 1 is 1.46 km/s with an approximate burn time of 41 min. The Delta-V for TEI 2 is 0.77 km/s with an approximate burn time of 14.8 min. The Mars to Earth Transfer time is 282 d with an Earth arrival date of May 15, 2027.

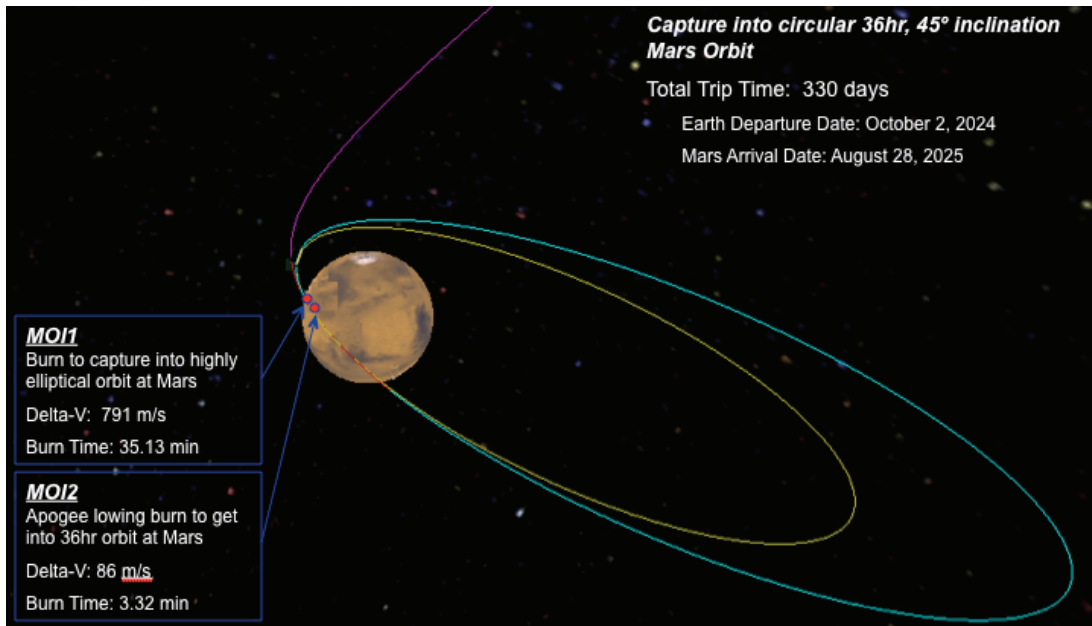

Figure 7. 2024 Launch Opportunity: MERV Insertion Maneuver Sequence to Capture Into 36 hr, 45° Inclined Orbit

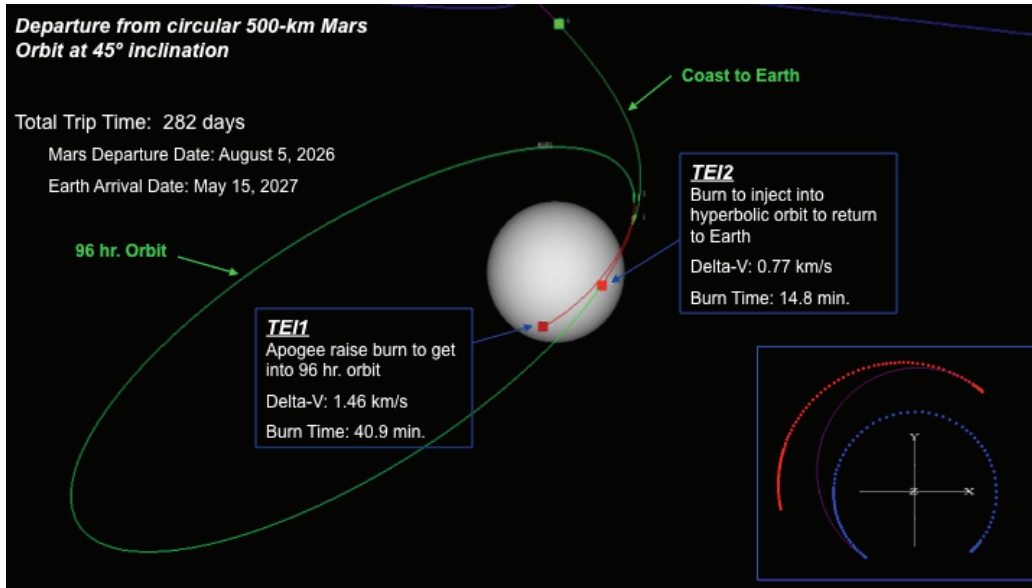

Figure 8. 2026 Mars Departure Opportunity: MERV TEI Maneuver Sequence to Depart From 36 hr, 45° Inclined Orbit

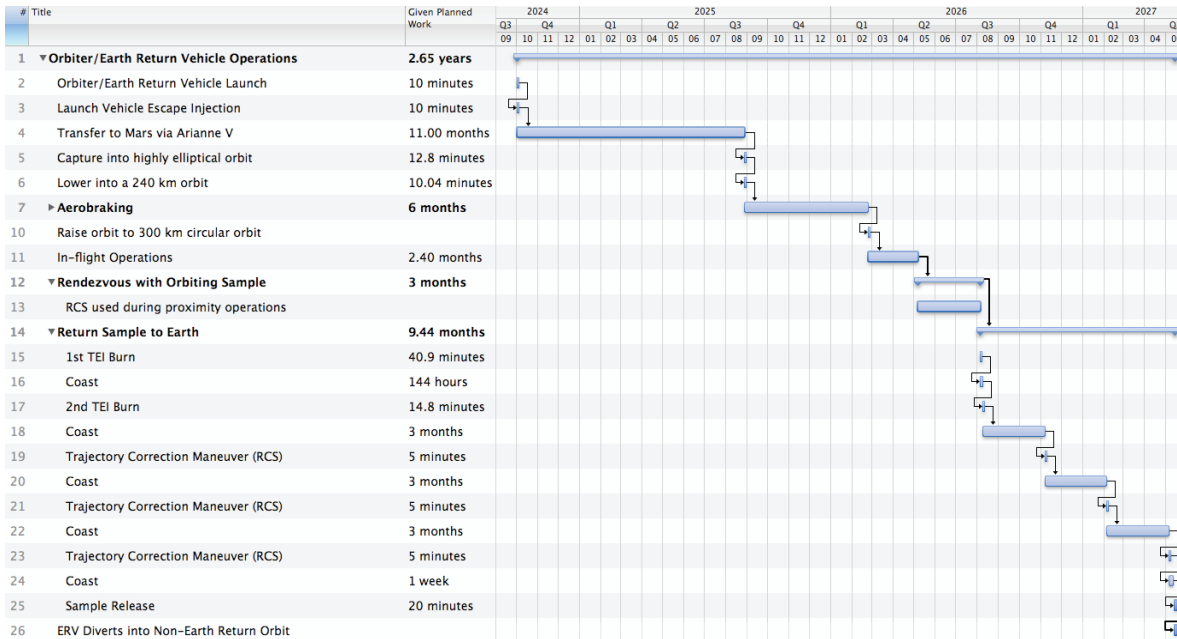

Figure 9. Case 4 Operational Timeline—2024 Launch Year

8. *Mission Analysis Event Timeline (Case 4. One AMBR)*

- Ariane V outbound time to capture orbit: 11 months
- Aerobraking: 6 months
- Chemical return time to Earth: 9.5 months

9. *Aerobraking Analysis Approach*

Instead of running aerobraking analysis for this study, the COMPASS design attempted to match Mars Reconnaissance Orbiter (MRO) ballistic parameters [<http://Marsprogram.jpl.nasa.gov/mro/>] and apply those to the aerobraking maneuvers in the Case 4 series.

- Coefficient of drag (C_d) = 2.2

- Ballistic coefficient = $15.5 \text{ kg/m}^2 = m/(Cd \cdot A)$
 - Required area = $2200 \text{ kg}/(2.2 \cdot 15.5 \text{ kg/m}^2) = 64.5 \text{ m}^2$
 - Two 6.2 m diameter Ultraflex ‘drag’ arrays (one ‘gore’ on each has solar cells)
 - Each requires a 1.5 m boom
 - Max pressure on each
 - Two 6.5 m drag flaps (assumes 2 m^2 for the body)
- Dynamic threshold = 0.33 N/m^2
 - Max force on a single array = 13 N
- Max heat flux = 0.16 W/cm^2
 - MERV heat = $0.16 \cdot \text{W/cm}^2 \cdot 82 \text{ m}^2 \cdot 100^2 = 130 \text{ kW}$

MRO Phases of Aerobraking

The MRO aerobraking details can also be found at the mission’s website. http://Marsprogram.jpl.nasa.gov/mro/mission/tl_aerobraking.html.

Table 5. Aerobraking Phases (Taken From MRO website)

| Aerobraking occurred in three primary phases: | | |
|---|---|---|
| Walk-in | Lasted about a week or 5 orbits | Engineers commanded the S/C to lower the periapsis (the closest point to Mars in its orbit) one orbit at a time, taking the S/C from its Mars orbit insertion altitude to its aerobraking altitude. This phase was used as a calibration period to understand atmospheric densities and the way in which the orbiter behaved in and out of aerobraking. |
| Main phase | Lasted about 5 1/2 months and fewer than 500 orbits | Once the orbiter reached its operational altitude (where the desired atmospheric densities were found), the main phase of aerobraking began. Engineers commanded the orbiter to make large-scale reductions in its orbit. If the altitude got too low, the S/C would be in danger of overheating; if the altitude got too high, and then aerobraking would finish too late. Therefore, small propulsive maneuvers were occasionally required to keep the orbiter within a specified “corridor” by raising or lowering its periapsis altitude. |
| Walk-out | Lasted about 5 d or 64 orbits | The walk-out phase occurred during the last few days of aerobraking. Engineers commanded the orbiter to increase its periapsis (the closest point it came to Mars in its orbit), causing the orbit to shrink more slowly. When the apoapsis (the farthest away from Mars the S/C reached in its orbit) was reduced to 450 km (280 miles), the periapsis was raised out of the atmosphere and aerobraking was complete. |

10. Aerobraking Drag Maneuver (from MRO design)

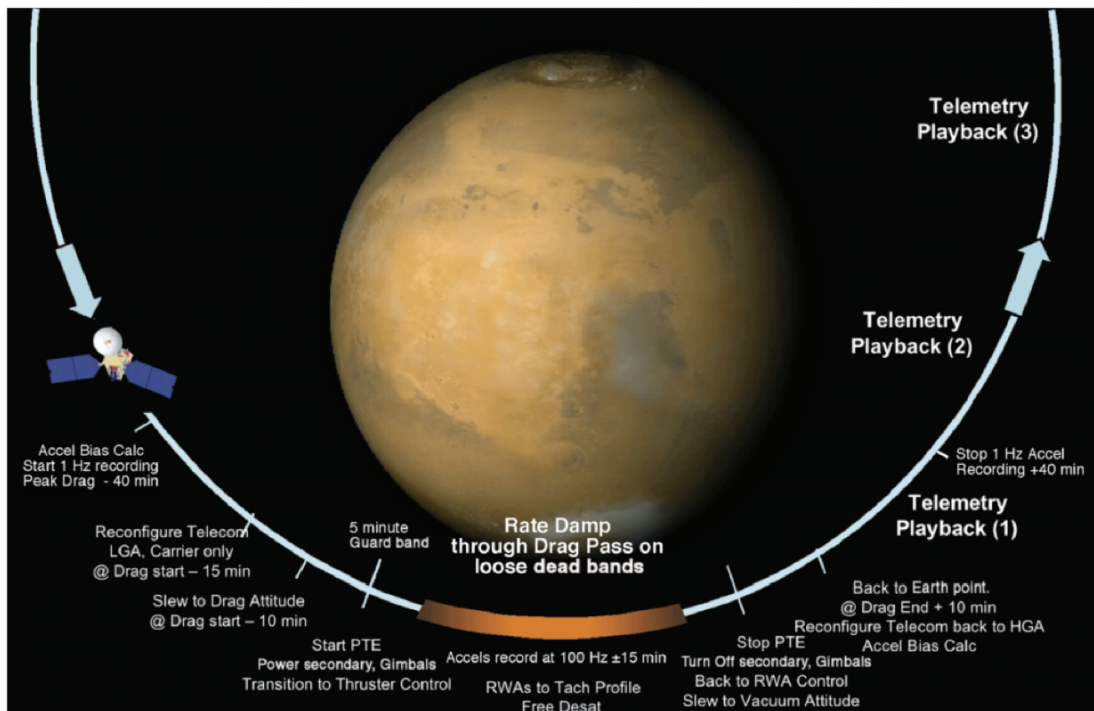

Figure 10. Sample Drag Pass Time Line

11. Aerobraking Trim Orbit Maneuver (from MRO design)

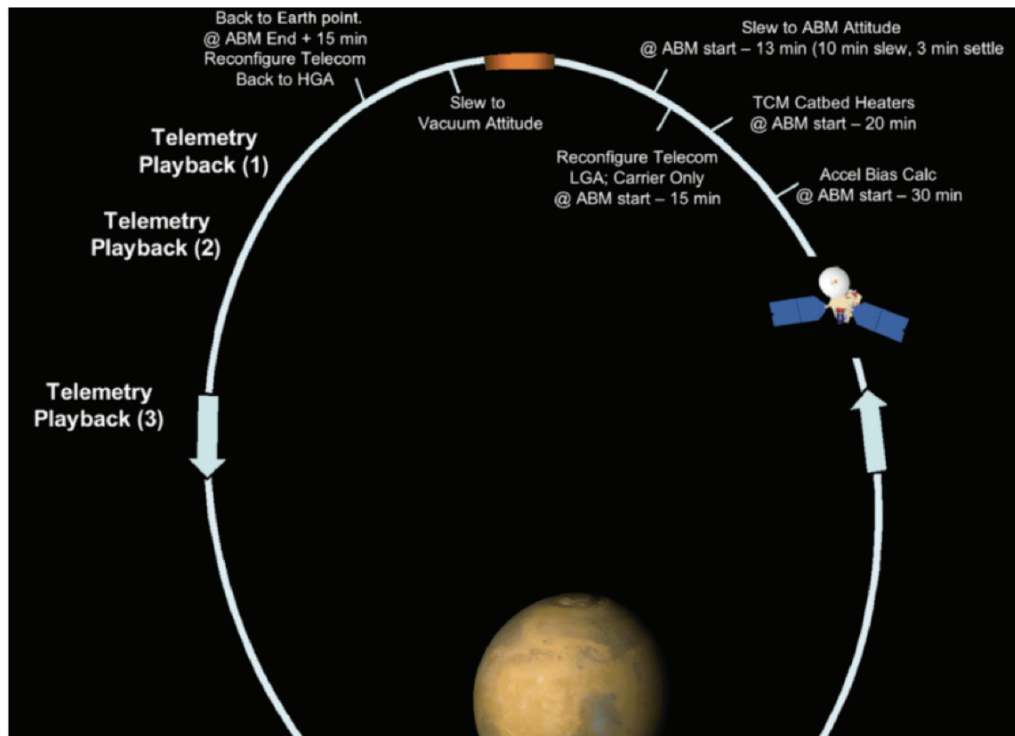

Figure 11. Sample Orbit Trim Timeline for Aerobraking

E. Sample Collection System

The sample collection system was not modeled in the COMPASS session but was rather a starting assumption based on the iMars concepts. The collection system estimated parameters as assumed are detailed below.

- Mass: 20 kg, 20% growth
- Power: 5 W

1. Capture Basket Concept

The capture basket concept system was not modeled in the COMPASS session but was rather a starting assumption. The Estimated Parameters as assumed are detailed below.

The Earth Entry Vehicle (EEV) is a 0.9 m diameter, 60° sheer-cone, <50 kg.

The assumed current best estimate (CBE) S/C wetmass of this EEV is 39 kg (CBE). The OS can be detected and tracked from as far as 1000's of km. The Beacon is OS as backup (received by orbiter Electra, a new proximity relay radio). The proximity navigation and capture is assumed to be autonomous. The capture basket draws the OS in and inserts into EEV.

The EEV as assumed below, is the given payload to be returned to Earth by the MERV vehicle designed in this session.

F. Launch Vehicle Details

1. Ariane V Performance

Ariane V is the European expendable launch vehicle baselined for this mission. For cases that could not fit onto the assumed performance of the Ariane V, Atlas or future assumed vehicles were used. The Ariane V has a cryogenic main stage and two solid rocket boosters. It is assumed that the Ariane V data launches to a -2° declination and has the adapter subtracted from its performance delivered to the mission C₃. Ariane 5 Evolution Core Ariane (ECA) is a higher capacity Ariane 5 Generic launcher. Although it has the same general architecture, a number of major changes have been made to the basic structure of the Ariane 5 Generic version to increase thrust and enable it to carry heavier payloads into orbit. [http://www.esa.int/SPECIALS/Launchers_Access_to_Space/SEM0LR2PGQD_0.html]

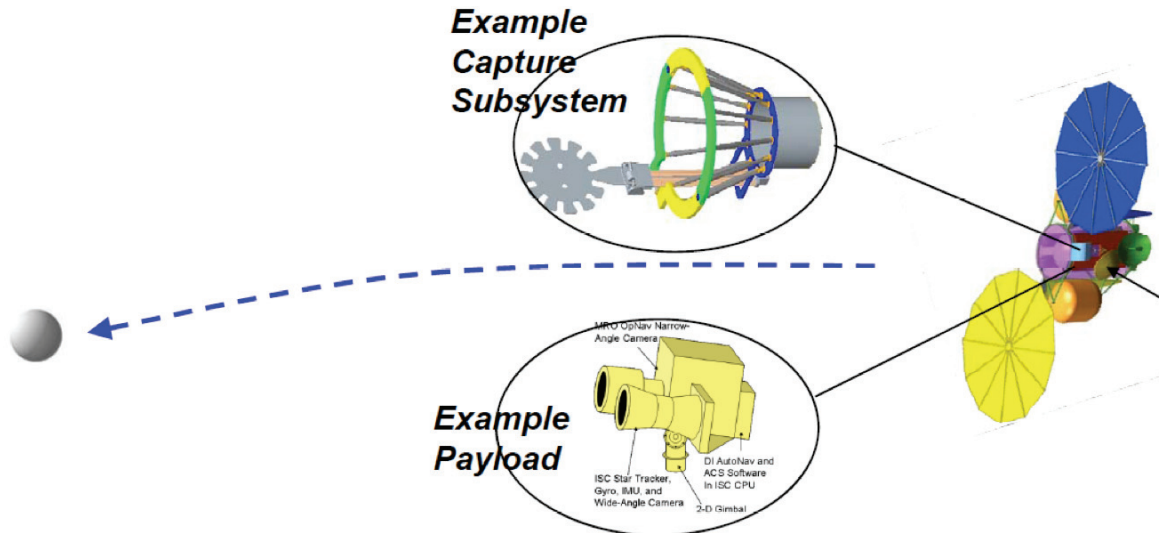

Figure 12. iMars Sample Collection Basket

2. Atlas V Performance

Because the Ariane V launch vehicle performance proved insufficient to close several of the missions in the trade space, the use of an Atlas V was added into the trade space. The assumptions of the performance of the Atlas V vehicle are included in this section for reference. These details were used by the configuration designer in packaging the stage into the payload fairing and by the structures engineer for load and launch variables used in structures calculations.

Launch vehicle contingency was assumed to be 10%, and was generated using the low thrust trajectory code Varitop.

The Atlas V launch vehicle system is based on the 3.8-m (12.5-ft) diameter Common Core Booster (CCB) powered by a single RD-180 engine. A three-digit naming convention was developed for the Atlas V launch vehicle system to identify its multiple configuration possibilities, and is indicated as follows: the first digit identifies the diameter class (in meters) of the payload fairing (4 or 5 m); the second digit indicates the number of solid rocket motors used (zero for Atlas V 400 series and zero to five for Atlas V 500 series); the third digit represents the number of Centaur engines (one or two).

3. Launch Vehicle Stowed Configuration—Case 2 (Baseline)

MERV will be launched and directly placed on its trajectory to Mars by the Ariane 5 launch vehicle. The height of the Ariane 5 PLF static envelope did not play a role in the design of the MERV S/C, while the 4.57 m static envelope diameter and standard payload adaptor systems proved to be a driving factor in sizing the S/C bus and, ultimately, the Ultraflex SA used by the SEP stage. The 1666 MVS Payload Adaptor System was selected because its 1.666 m S/C interface diameter allowed the S/C bus structure to be an efficient thrust tube design that can house a majority of the subsystem components internally, while maximizing the diameter of the Ultraflex SA that could be stowed within the fairing envelope. Figure 13 and Figure 14 show the S/C in its stowed configuration within the Ariane 5 PLF.

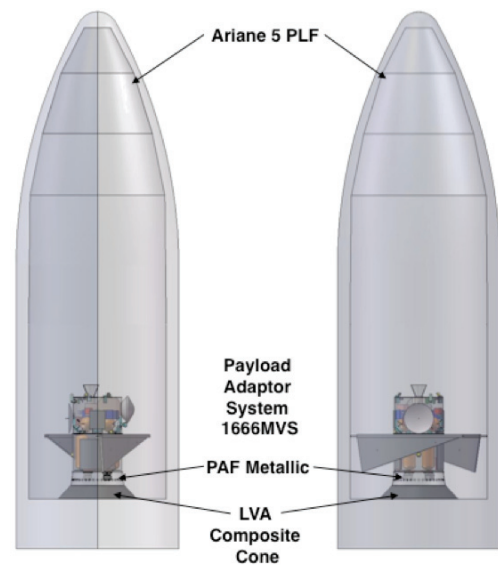

Figure 13. MERV Case 2 Stowed Within the Ariane 5 PLF

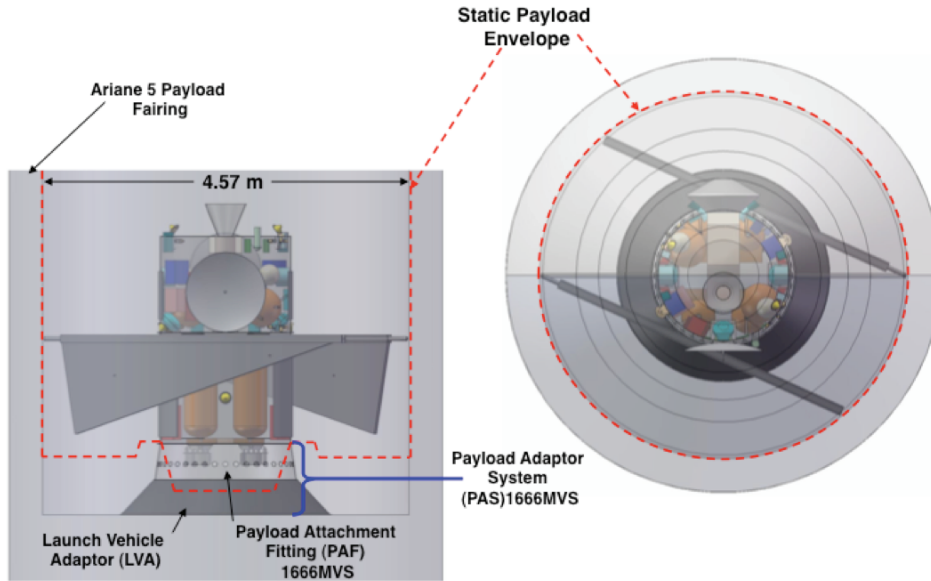

Figure 14. Close-Up and Top View of MERV CASE 2 Stowed Within the Ariane 5 PLF

4. Launch Vehicle Stowed Configuration—Case 4—One AMBR

MERV will be launched and directly placed on its trajectory to Mars by the Ariane 5 launch vehicle. The height of the Ariane 5 PLF static envelope did not play a role in the design of the MERV S/C, and the 4.57 m diameter static envelope is sufficient for packaging the Ultraflex SA/drag flaps required for the mission. The 1666 MVS Payload Adaptor System was selected because its 1.666 m S/C interface diameter allowed the S/C bus structure to be an efficient thrust tube design that can house a majority of the subsystem components internally, while allowing the arrays/drag flaps to be stowed externally to the bus and fitting well within the fairing envelope. Figure 15 and Figure 16 show the S/C in its stowed configuration within the Ariane 5 PLF.

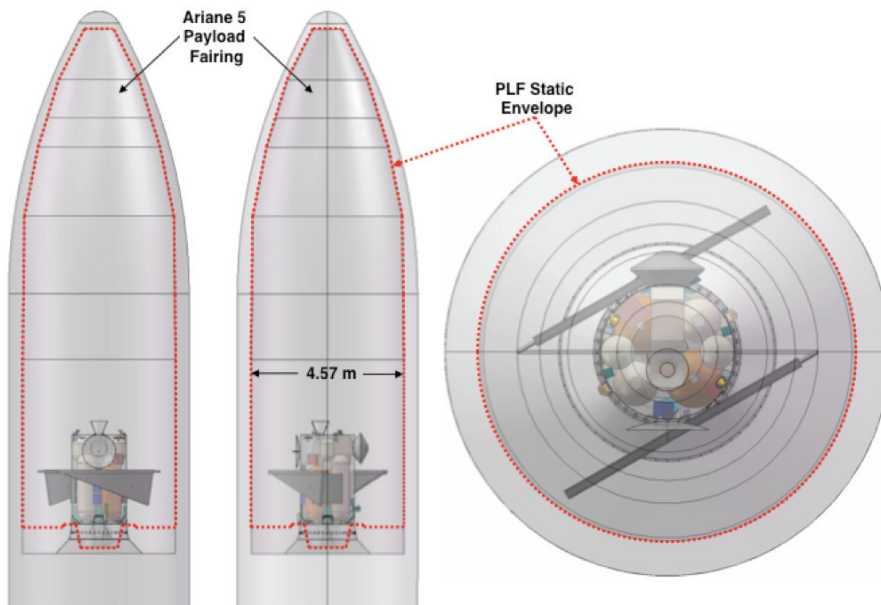

Figure 15. MERV Case 4—One AMBR Stowed Within the Ariane 5 PLF

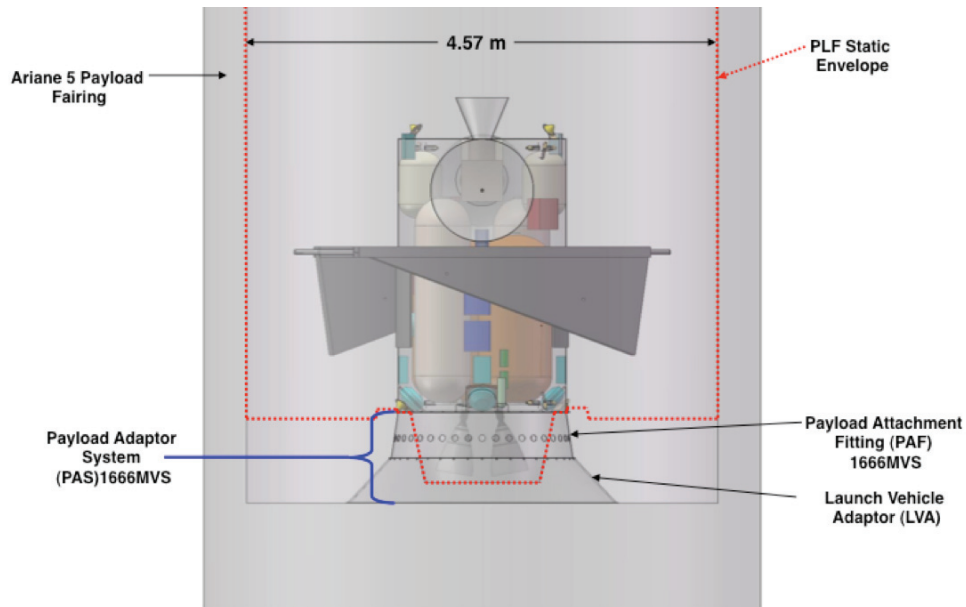

Figure 16. Close-Up of MERV Case 4—One AMBR Stowed Within the Ariane 5 PLF

G. Baseline CONOPS

The CONOPS described below was from the iMARS mission and includes assumptions for the arrival and operation of the Sample capture and return to Earth by an ERV. For this design study, MERV is the name of COMPASS' design of an ERV.

- The orbiter is launched either directly to Mars or targets an Earth gravity assist to Mars (baseline) using an Ariane V ECA.
- Orbiter performs a propulsive MOI into an elliptical 1 to 3 day orbit with a 240 km periapsis (apoapsis 35,000 to 75,000 km)
- The orbiter aerobrakes for 6 months into a roughly 500 km circular orbit
 - Mars program has indicated its desire to evaluate eliminating the aerobraking, considered potentially too high of a risk to a complex mission, this study found the only solution, given the launcher constraints is to use SEP
- From the 500 km circular orbit, the Orbiter/ERV(MERV for this study) would maneuver to, rendezvous with, and capture, the OS
 - OS is a 15 cm diameter sphere with mass of 5 kg
 - Detection of the OS once in orbit is baselined to be via an OpNav camera for optical navigation from MRO and Mars Telecommuting Orbiter (MTO).
 - http://en.wikipedia.org/wiki/Mars_Telecommunications_Orbiter
 - Desired to have UHF beacon on the OS.
 - Wide angle camera flown on Mars Exploration Rover (MER) is planned for close proximity operations. [<http://Marsrovers.nasa.gov/home/index.html>]
- The S/C would then initiate a Type-I cruise to Earth.
 - A type 1 trajectory in this instance is one in which the orbit transfer true anomaly is between 0° and 180°. It is less than a 180° transfer.
 - Initially targeted to pass by Earth, the Orbiter would be retargeted in the last few days to release the EEV, from 4 hr out, then divert into a non-Earth-return trajectory.
- The orbiter/MERV carries the EEV and the equipment for detection, rendezvous, and the capture of the OS and transfer of the OS to the EEV, the spin/release mechanism for the EEV, and the propulsion for Earth return.
- MOI and TEI baselined 3000 kg of monopropellant for the mission.

H. System Design Trade Space

Table 6. Trade Space

| Case number | Study name | Description |
|-----------------------------|--|--|
| Case 1 | SEP outbound, Return Chemical Stage | SEP stage to deliver the return stage to Mars orbit, and spiral in orbit for rendezvous with sample capsule. Chemical Stage to return sample to Earth |
| Case 2 Baseline | All SEP | SEP stage to deliver the return stage to Mars orbit, and spiral in orbit for rendezvous with sample capsule. SEP Stage then return samples to Earth |
| Case 3 | All Chemical | Chemical stage to deliver the return stage to Mars' orbit, rendezvous with sample capsule. Chemical Stage then return samples to Earth |
| Case 3 Drop | All Chemical with dropped items | Chemical stage to deliver the return stage to Mars' orbit, rendezvous with sample capsule. Chemical Stage then return samples to Earth. Drop tanks used for outbound propellant, and drop UHF antenna and tanks with associated structure |
| Case 3 Drop 2 | All Chemical only dropping tanks | Chemical stage to deliver the return stage to Mars' orbit, rendezvous with sample capsule. Chemical Stage then return sample to Earth. Drop tanks used for outbound propellant with associated structure |
| Case 4 | All Chemical with Aerobraking | Chemical stage to deliver the return stage to Mars' orbit, rendezvous with sample capsule. Chemical Stage then return sample to Earth. Using Aerobraking to slow down and get down to low Mars orbit for sample rendezvous. Launch in 2024 |
| Case 4 Drop | All Chemical with Aerobraking and dropping stage | Chemical stage to deliver the return stage to Mars' orbit, rendezvous with sample capsule. Chemical Stage then return sample to Earth. Using Aerobraking to slow down and get down to low Mars orbit for sample rendezvous. Drop the AB stage after capture into orbit. Launch in 2024 |
| Case 4 One AMBR Baseline | All Chemical with Aerobraking, using one AMBR engine for return to Earth | Chemical stage to deliver the return stage to Mars' orbit, rendezvous with sample capsule. Chemical Stage then return sample to Earth. Using Aerobraking to slow down and get down to low Mars orbit for sample rendezvous. One AMBR engine (Isp = 333 s) for MOI and return. Launch in 2024 |
| Case 4 One engine | All Chemical with Aerobraking | Chemical stage to deliver the return stage to Mars' orbit, rendezvous with sample capsule. Chemical Stage then return sample to Earth. Using Aerobraking to slow down and get down to low Mars orbit for sample rendezvous. One fictional 300 s engine for MOI and return. Launch in 2024 |
| Case 4 2022 | All Chemical with Aerobraking | Chemical stage to deliver the return stage to Mars' orbit, rendezvous with sample capsule. Chemical Stage then return sample to Earth. Using Aerobraking to slow down and get down to low Mars orbit for sample rendezvous. Launch in 2022 |

I. Baseline System Design(s)

Of the trade space, two of the cases were chosen as representative of their technology and considered the baselines for this study. This report will attempt to document the details of two of the cases listed above: all SEP Case 2 and Chemical/Aerobrake Case 4—One AMBR. These cases used the same two MELs to create the stages and added details to those MELs where appropriate.

The design of the MERV vehicle is divided into two main stages in terms of mission events: (1) an Outbound stage that performs the mission from Earth to Mars (MOI) and (2) a Return stage which brings the Mars sample back to Earth (TEI). For some of the cases, the stages are separate propulsion systems, and for some of the cases in the trade space, the stages are the same propulsion system.

The MELs follow a Work Breakdown Structure (WBS) numbering convention in which the main vehicle is numbered started at 0X, usually at 06 following the project management conventions of WBS numbering. Subsystems begin with 0X.0X. Subelements below those subsystems further break down with an additional decimal point and numbering 0X.X.X. The elements under those, if there are more, begin using alphabet numbering starting with a through z.

1. Return Stage MEL

The Return Stage MEL (starting at WBS 06) was the stage which performs the TEI burn and contains the propulsion, avionics, comm., thermal, power, etc for the return to Earth portion of the mission. For the all-SEP case, the SEP stage alone performs both the Mars Orbit Insertion burn as well as the TEL burn. The return stage, in this case, contains all the components that would have been on the chemical return stage (avionics, etc) but not the propulsion system. The return stage was subdivided into a WBS elements 06.1 Sample Collection Device, and 06.2, The S/C bus. The Bus itself was then divided up into subelements as follows (Table 7 and Table 15 further illustrate how this was applied to the design):

- 06.2.1 Attitude Determination and Control
- 06.2.2 Command and Data Handling
- 06.2.3 Communications and Tracking

- 06.2.4 Electrical Power Subsystem
- 06.2.5 Thermal Control (non-Propellant)
- 06.2.6 Propulsion
- 06.2.7 Propellant
- 06.2.8 Structures and Mechanisms

2. *SEP Stage MEL*

The SEP Stage MEL (starting at WBS 07) was constructed to allow for an SEP stage is assumed to be developed previous to the Mars Sample Return mission and is therefore available for this mission as an ‘off-the-shelf’ stage. The top portion of the SEP stack is therefore just the control spacecraft and the sampling mechanism. In the all SEP case, enough Xe propellant is carried in the SEP Stage to perform both the MOI and the TEI burns. This made for simpler modeling by the design team. The SEP Stage was subdivided into WBS element 07.1 SEP Stage. The Bus itself was then divided up into subelements as follows (Table 8 and Table 16 further illustrate how this was applied to the design):

- 07.1.1 Avionics
- 07.1.2 Communications and Tracking
- 07.1.3 Guidance, Navigation and Control
- 07.1.4 Electrical Power Subsystem
- 07.1.5 Thermal Control (non-Propellant)
- 07.1.6 Propulsion
- 07.1.7 Propellant
- 07.1.8 Structures and Mechanisms

II. Baseline Design (Case 2—All SEP)

A. Top Level Design (MEL and PEL)

The all-SEP Case 2 design used both the Return Stage MEL (WBS 06) and the SEP Stage MEL (WBS 07) as described in Sections I.I.1 and I.I.2 to build the vehicle. The SEP stage MEL was used to house the components unique to the SEP stage itself: thrusters, propellant, thermal, arrays, structure. The return stage MEL was used to house the same avionics, GN&C, Comm and Science collection device used as in all cases, not just the all-SEP case. *However, for the All-SEP case 2 the SEP stage is never separated and the entire stack is returned to an earth flyby.*

1. *Master Equipment List (MEL)—SEP Stage (Case 2—Baseline)*

Table 7 lists the top level of the MEL of the return stage portion of the S/C design in Case 2 with all the subsystem line elements hidden such that only the top-level masses are shown.

Table 7. MEL—Return Stage

| WBS | Description | QTY | Unit Mass | Basic Mass | Growth | Growth | Total Mass |
|--------|--|-----|-----------|------------|--------|--------|------------|
| Number | Earth Return Vehicle (March 2009) - Case 2 | | (kg) | (kg) | (%) | (kg) | (kg) |
| 06 | MERV Sample Return Spacecraft | | | 490.33 | 15.4% | 75.63 | 565.96 |
| 06.1 | Sample Collection Device | | | 62.00 | 23.4% | 14.50 | 76.50 |
| 06.2 | Spacecraft Bus | | | 428.33 | 14.3% | 61.13 | 489.46 |
| 06.2.1 | Attitude Determination and Control | | | 58.40 | 19.1% | 11.18 | 69.58 |
| 06.2.2 | Command and Data Handling | | | 35.88 | 19.2% | 6.90 | 42.78 |
| 06.2.3 | Communications and Tracking | | | 44.00 | 20.0% | 8.80 | 52.80 |
| 06.2.4 | Electrical Power Subsystem | | | 29.00 | 34.1% | 9.90 | 38.90 |
| 06.2.5 | Thermal Control (Non-Propellant) | | | 32.94 | 18.0% | 5.93 | 38.87 |
| 06.2.6 | Propulsion | | | 49.04 | 23.2% | 11.39 | 60.43 |
| 06.2.7 | Propellant | | | 136.74 | 0.0% | 0.00 | 136.74 |
| 06.2.8 | Structures and Mechanisms | | | 42.33 | 16.6% | 7.03 | 49.35 |

Table 8 lists the top level of the MEL of the SEP stage portion of the S/C design in Case 2 with all the subsystem line elements hidden such that only the top-level masses are shown.

The total growth on the dry mass of the S/C is then rolled up to find a total growth mass and growth percentage. Engineers enter in the CBE mass for each of their line elements, as well as quantity. Then the Growth column is where each subsystem lists the recommended growth factor on each line items following the AIAA WGA schedule .

The MEL takes all of the items and racks them up into totals and calculates a total CBE mass, a total mass and a total growth mass.

Table 8. MEL—SEP Stage

| WBS Number | Description SEP Vehicle - Case 2 | QTY | Unit Mass (kg) | CBE Mass (kg) | Growth (%) | Growth (kg) | Total Mass (kg) |
|------------|--|-----|-------------------|------------------|---------------|----------------|--------------------|
| 07 | MERV SEP Stage | | | 2478.4 | 8% | 193.4 | 2671.8 |
| 07.1 | SEP Stage | | | 2478.4 | 8% | 193.4 | 2671.8 |
| 07.1.1 | Avionics | | | 14.2 | 13% | 1.9 | 16.1 |
| 07.1.2 | Communications and Tracking | | | 1.2 | 20% | 0.2 | 1.4 |
| 07.1.3 | Guidance, Navigation, and Control (GN&C) | | | 0.0 | 0 | 0.0 | 0.0 |
| 07.1.4 | Electrical Power Subsystem | | | 293.0 | 33% | 95.3 | 388.3 |
| 07.1.5 | Thermal Control (Non-Propellant) | | | 79.8 | 18% | 14.4 | 94.2 |
| 07.1.6 | Structures and Mechanisms | | | 126.1 | 19% | 24.6 | 150.6 |
| 07.1.7 | Propulsion System | | | 228.0 | 25% | 57.0 | 285.0 |
| 07.1.8 | Propellant | | | 1736.2 | 0% | 0.0 | 1736.2 |

2. Power Equipment List (PEL)—SEP Stage (Case 2—Baseline)

The power listing below was broken down by subsystem and then by operation phase of the mission. All subsystems power requirements are estimated from a bottom’s up subelement-by-subelement summation. However, the power system tracks its own power and must provide for itself. When the power system is sized, these loads are added to the load required by the power system itself. Note that during eclipse times at Mars, the SEP thrusters will not be operating.

Figure 17 shows the power produced by the SAs over the course from launch to the end of the mission. The curves in blue indicate the amount of power that can be produced by the SAs. Recall that this is a round trip mission. The blue curve falls off as the MERV S/C reaches Mars and then grows again once the MERV S/C has left Mars and is returning to the Earth. The curves in red indicate the amount of power that will be utilized by the thrusters. Note that the amount of power required by the thrusters never exceeds that which can be produced by the arrays throughout the mission and as the MERV S/C distance to the Sun increases. Assume that the vehicle is located at Earth or Mars when the utilized power value is zero (i.e., no thrusting).

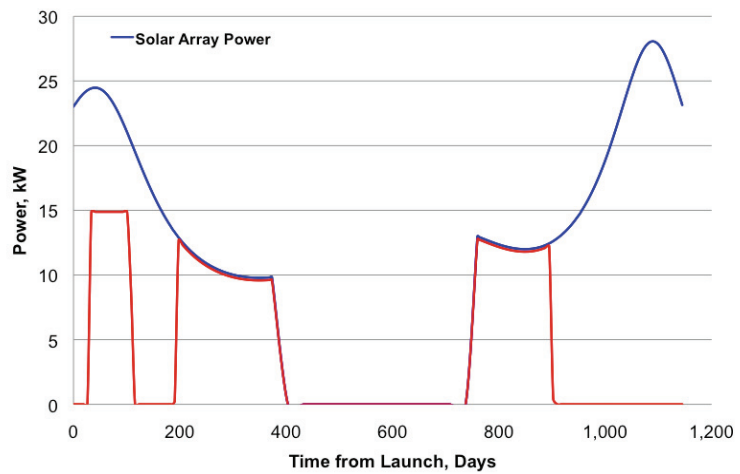

Figure 17. Power from SA Over Mission Elapsed Time

The nominal power for each of the three BPT-4000 thrusters is 4500 W plus an extra 500 W (4500 W + 500 W per thruster times three thrusters) for off-nominal situations/margin giving a total of 15000 W power to thrusters. Housekeeping power requirements were roughly an additional 500 kWe. This results in approximately 15500 W total required during phases of SEP thrusting. The power system will use the remaining available power during the Spiral in LMO (<15 kW). The requirement backed off to SAs capable of producing 24 kWe at 1 AU in order to provide the 15.5 kWe required in Mars orbit. The total power required for the systems of the S/C during major mission operations are captured in Table 9.

The maximum thermal waste heat generated is ~1650 W. This number was used by the thermal subsystem to design radiators and other thermal heat rejection systems

Table 9. PEL—Case 2 (All-SEP)

| Waste Heat | Propulsion, W | Avionics, W | Comm., W | Thermal, W | GN&C, W | Power, W | Science, W | SEP Stage, W | CBE Total, W | 30 % Margin, W | Total, W |
|---------------------------------|------------------|----------------|-------------|---------------|------------|-------------|---------------|-----------------|-----------------|----------------------|-------------|
| Launch | 90 | 61 | 0 | 8 | 15 | 0 | 0 | 142 | 317 | 52.4 | 369 |
| Launch Vehicle Escape Injection | 90 | 61 | 85 | 8 | 15 | 0 | 0 | 142 | 402 | 77.9 | 480 |
| Checkout | 90 | 61 | 85 | 8 | 115 | 0 | 15 | 15030 | 15405 | 112.4 | 15517 |
| Wheel ACS Control | 150 | 61 | 0 | 8 | 15 | 0 | 2 | 142 | 379 | 71.0 | 450 |
| In Flight Ops (ACS) | 90 | 61 | 0 | 8 | 92 | 0 | 2 | 15030 | 15284 | 76.2 | 15361 |
| Spiral into LMO (SEP) | 90 | 61 | 0 | 8 | 92 | 0 | 2 | 15030 | 15284 | 76.2 | 15361 |
| Mars Orbit Loiter | 150 | 61 | 0 | 8 | 15 | 0 | 2 | 15030 | 15267 | 71.0 | 15338 |
| Rendezvous with Sample (ACS) | 150 | 61 | 0 | 8 | 92 | 0 | 2 | 142 | 456 | 94.2 | 550 |
| Spiral and Earth Return | 90 | 61 | 85 | 8 | 92 | 0 | 2 | 15030 | 15369 | 101.7 | 15471 |
| Sample Return Coast | 90 | 61 | 0 | 8 | 92 | 0 | 2 | 15030 | 15284 | 76.2 | 15361 |
| Sample Return TCM | 90 | 61 | 85 | 8 | 92 | 0 | 2 | 142 | 481 | 101.7 | 583 |
| Sample Release | 150 | 61 | 85 | 8 | 92 | 0 | 2 | 142 | 541 | 119.7 | 661 |
| Disposal | 90 | 61 | 85 | 8 | 92 | 0 | 2 | 15030 | 15369 | 101.7 | 15471 |

| Waste Heat | Propulsion, W | Avionics, W | Comm., W | Thermal, W | GN&C, W | Power, W | Science, W | SEP Stage, W | CBE Total, W | 30 % Margin, W | Total, W |
|---------------------------------|------------------|----------------|-------------|---------------|------------|-------------|---------------|-----------------|-----------------|----------------------|-------------|
| Launch | 0 | 61 | 0 | 0 | 15 | 0 | 0 | 10 | 87 | 26.0 | 113 |
| Launch Vehicle Escape Injection | 0 | 61 | 43 | 0 | 15 | 0 | 0 | 10 | 129 | 38.7 | 168 |
| Checkout | 0 | 61 | 43 | 0 | 115 | 0 | 1 | 1052 | 1272 | 381.6 | 1654 |
| Wheel ACS Control | 0 | 61 | 0 | 0 | 15 | 0 | 0 | 10 | 87 | 26.0 | 113 |
| In Flight Ops (ACS) | 0 | 61 | 0 | 0 | 92 | 0 | 0 | 1052 | 1206 | 361.9 | 1568 |
| Spiral into LMO (SEP) | 0 | 61 | 0 | 0 | 92 | 0 | 0 | 1052 | 1206 | 361.9 | 1568 |
| Mars Orbit Loiter | 0 | 61 | 0 | 0 | 15 | 0 | 0 | 1052 | 1129 | 338.7 | 1468 |
| Rendezvous with Sample (ACS) | 0 | 61 | 0 | 0 | 92 | 0 | 0 | 10 | 164 | 49.2 | 213 |
| Sample Return TEI Burn | 0 | 61 | 43 | 0 | 92 | 0 | 0 | 1052 | 1249 | 374.6 | 1623 |
| Sample Return Coast | 0 | 61 | 0 | 0 | 92 | 0 | 0 | 1052 | 1206 | 361.9 | 1568 |
| Sample Return TCM | 0 | 61 | 43 | 0 | 92 | 0 | 0 | 10 | 207 | 62.0 | 269 |
| Sample Release | 0 | 61 | 43 | 0 | 92 | 0 | 0 | 10 | 207 | 62.0 | 269 |
| Disposal | 0 | 61 | 43 | 0 | 92 | 0 | 0 | 1052 | 1249 | 374.6 | 1623 |

B. System Level Summary—Case 2 (All SEP)

The MEL (Table 10) captures the bottoms-up estimation of CBE and growth percentage line item by item from the subsystem designer for the Case 2 all-SEP Return Stage MEL and the SEP Stage MELs respectively. Table 10 and Table 11 wraps up those total masses, CBE and total mass after applied growth percentage for each stage. In order to meet the total of 30% at the system level, an allocation is necessary for system level growth. This additional system level mass is assumed as part of the inert mass that is flown along the required trajectory. Therefore, the additional system level growth mass impacts the total propellant loading for the mission design. In the table, the first MEL is for the Return Stage responsible for the TEI burn to return the sample to Earth of MERV (in this MEL setup consisting of data in WBS 06). While this case is actually a single stage (all SEP) the configuration of the MEL separated out the chemical systems into the return stage and the SEP systems into the SEP stage (Table 12). Table 12 stacks up the total mass with growth of the two stages, and determines whether the total of the two stages together is less than the launch vehicle performance allocated to the vehicle (i.e., the ideal ELV performance—10% margin).

Table 11 is the system summary of the SEP stage of Case 2. The SEP stage is the portion of the MEL starting with WBS line element 07 and containing the EP thrusters, solar power source, etc. Most of the communications system and electronics are located in the MERV portion of this MEL in order to provide ease for the design engineers to maintain the same components in Cases 1 and 2 that did not change with propulsion system.

Table 10. System Summary—WBS 06 MERV Return Stage (Never Separated from the SEP Stage)

| Spacecraft Master Equipment List Rack-up (Mass) - ERV | | | | COMPASS S/C Design | |
|---|---|------------------|-------------|--------------------|----------------------|
| WBS | Main Subsystems | Basic Mass (lkg) | Growth (kg) | Total Mass (kg) | Aggregate Growth (%) |
| 06 | MERV Sample Return Spacecraft | 490.3 | 75.6 | 566.0 | |
| 06.1 | Sample Collection Device | 62.0 | 14.5 | 76.5 | 23% |
| 06.1.1.a | Sample Collection Mechanism | 20 | 4 | 24.0 | 20% |
| 06.1.1.b | Sample Capsule | 39 | 9.75 | 48.8 | 25% |
| 06.1.1.c | Sample Separation Mechanisms | 3 | 0.75 | 3.8 | 25% |
| 06.2 | Spacecraft Bus | 428.3 | 61.1 | 489.5 | |
| 06.2.1 | Attitude Determination and Control | 58.4 | 11.2 | 69.6 | 19% |
| 06.2.2 | Command and Data Handling | 35.9 | 6.9 | 42.8 | 19% |
| 06.2.3 | Communications and Tracking | 44.0 | 8.8 | 52.8 | 20% |
| 06.2.4 | Electric Power | 29.0 | 9.9 | 38.9 | 34% |
| 06.2.5 | Thermal Control | 32.9 | 5.9 | 38.9 | 18% |
| 06.2.6 | Propulsion | 49.0 | 11.4 | 60.4 | 23% |
| 06.2.7 | Propellant | 136.7 | | | |
| 06.2.8 | Structures and Mechanisms | 42.3 | 7.0 | 49.4 | 17% |
| | Estimated Spacecraft Dry Mass | 354 | 76 | 429.2 | 21% |
| | Estimated Spacecraft Wet Mass | 490 | 76 | 566 | |
| System Level Growth Calculations | | | | | Total Growth |
| | Dry Mass Desired System Level Growth | 354 | 106 | 459.7 | 30% |
| | Additional Growth (carried at system level) | | 30 | | 9% |
| | Total Wet Mass with Growth | 490 | 106 | 596.4 | |

Table 11. System Summary—WBS 07 SEP Stage

| Spacecraft Master Equipment List Rack-up (Mass)- SEP Stage | | | | | |
|--|---|------------------|--------------|-----------------|----------------------|
| WBS | Main Subsystems | Basic Mass (lkg) | Growth (kg) | Total Mass (kg) | Aggregate Growth (%) |
| 07 | MERV SEP Stage | 2478.4 | 193.4 | 2671.8 | |
| 07.1 | SEP Stage | 2478.4 | 193.4 | 2671.8 | 8% |
| 07.1.1 | Avionics | 14.2 | 1.9 | 16.1 | 13% |
| 07.1.2 | Communications and Tracking | 1.2 | 0.2 | 1.4 | 20% |
| 07.1.3 | Guidance, Navigation, and Control (GN&C) | 0.0 | 0.0 | 0.0 | TBD |
| 07.1.4 | Electrical Power Subsystem | 293.0 | 95.3 | 388.3 | 33% |
| 07.1.5 | Thermal Control (Non-Propellant) | 79.8 | 14.4 | 94.2 | 18% |
| 07.1.6 | Structures and Mechanisms | 126.1 | 24.6 | 150.6 | 19% |
| 07.1.7 | Propulsion System | 228.0 | 57.0 | 285.0 | 25% |
| 07.1.8 | Propellant | 1736.2 | | | |
| | Estimated Spacecraft Dry Mass | 742 | 193 | 935.6 | |
| | Estimated Spacecraft Wet Mass | 2478 | 193 | 2672 | |
| System Level Growth Calculations | | | | | Total Growth |
| | Dry Mass Desired System Level Growth | 742 | 223 | 964.9 | 30% |
| | Additional Growth (carried at system level) | | 29 | | 4% |
| | Total Wet Mass with Growth | 2478 | 223 | 2701.1 | |

Table 12 summarized the total masses of the ERV portion of the MEL with the SEP stage portion of the overall MEL together in order to come up with the total launched wet mass of the MERV design concept vehicle. The total wet mass, with 30% growth on dry mass, of Case 2 is 3297.5 kg. The available launch performance to the C₃ of this mission is 3667 kg leaving 10% launch margin available.

Table 12. MEL—SEP Stage

| Combined Total Spacecraft Mass (SEP Stage + Return Stage) | Basic mass (lkg) | Growth (kg) | Total mass (kg) |
|--|------------------|-------------|-----------------|
| Total Spacecraft Wet Mass | 2969 | 329 | 3297.5 |
| Available Launch Performance to C ₃ (kg) | ----- | ---- | 3666.7 kg |
| Launch Margin (%) | ----- | ---- | 10.0 % |
| Launch margin (kg) | ----- | ---- | 366.7 kg |
| Available Launch Performance to C ₃ (after ELV margin) (kg) | ----- | ---- | 3300.0 kg |
| Additional Launch margin available (kg) | ----- | ---- | 2.5 kg |
| Additional Launch margin available (%) | ----- | ---- | 0.1 % |
| Total Launch margin available (kg) | ----- | ---- | 369.2 kg |
| Total Launch margin available (%) | ----- | ---- | 10.1 % |

The Return Stage or Control Spacecraft, again, contains the avionics, communications, power, etc., for the vehicle. The SEP Stage only contains the propulsion system, thermal, etc.

Table 13. Stage Dry, Wet and Inert Mass Calculations

| Spacecraft Totals | |
|------------------------------|-----------|
| SEP Stage | |
| MERV SEP Stage Wet mass | 2701.1 kg |
| MERV SEP Stage Dry mass | 964.9 kg |
| MERV SEP Stage Inert mass | 1102.4 kg |
| Return Stage | |
| MERV Return Stage Wet mass | 596.4 kg |
| MERV Return Stage Dry mass | 459.7 kg |
| MERV Return Stage Inert mass | 475.2 kg |

Table 14. Architecture Top-Level Summary

| Architecture details | Mass (kg) |
|--|---------------------------------------|
| Launch Vehicle | Ariane V |
| ELV Performance to C ₃ target | 3666.7 kg |
| ELV Margin (Percent) | 10% |
| ELV Margin (Mass) | 366.7 kg |
| Spacecraft Adaptor To ELV Mass | 160 kg |
| ELV Margin After Adaptor | 207 kg |
| ELV Margin After Adaptor | % |
| ELV Performance After Margin | 3300 kg |
| C ₃ Targeted | 15.60 km ² /s ² |
| Mission Total Trip time to Mars | 373 d |
| Mission time, spiral at Mars | 185.0 d |
| Science Payload Delivered | 76.50 kg |
| SC Wet Mass w/ System Growth | 3297 kg |
| Total Launch Margin Available | 10.1 % |

C. Design Concept Drawing and Description—Case 2 (all SEP)

The Case 2 design for the MERV consists of a dedicated SEP stage and a return stage consisting of all the nonpropulsive elements and subsystem components specific to the Mars Sample Return mission. All the major propulsive phases of the mission will be performed by the SEP stage, while the return stage provides all avionics, GN&C, communications, RCS, and functionality related to sample rendezvous, capture, and Earth entry. Figure 18 shows the entire vehicle fully deployed while Figure 19 shows a close-up of both stages, again in the deployed configuration. *Recall that the nomenclature ‘return stage’ is an artifact of the trade space; Case 2 (all SEP) never separates the SEP stage, thus the ‘return stage’ is not a stage but a control spacecraft with the sampling mechanisms.*

The dedicated SEP stage primary structure is comprised of a thrust tube that is designed to mate directly to the metallic PAF and utilize the standard separation system contained on the PAF. Use of a thrust tube design with the same diameter as the PAF interface allowed the structure mass to be minimal while providing sufficient internal volume to house the subsystem components, mount those components directly to the thrust tube structure, and handle the load of the return stage during launch. All components contained on the SEP stage are shown in Figure 20. The SEP stage design was intended to provide a dedicated SEP propulsion stage that was capable of a variety of missions with the addition of a payload stage (in this case the return stage) that would be designed to provide the mission specific capabilities.

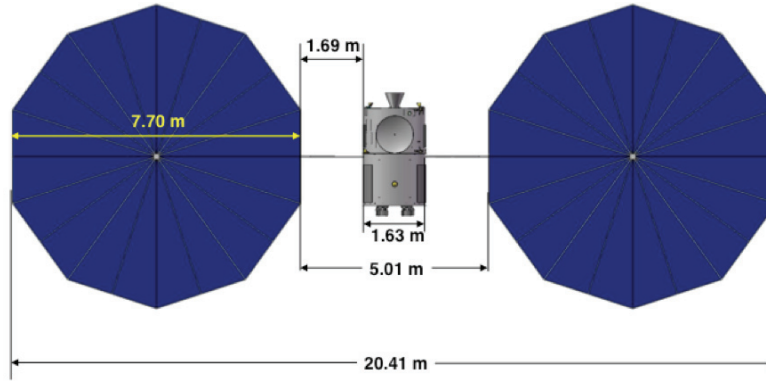

Figure 18. MERV Case 2 Vehicle Fully Deployed with Dimensions

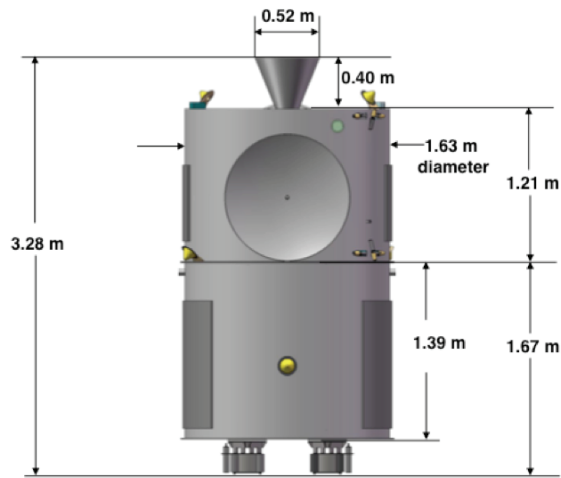

Figure 19. Close-up of MERV Case 2 Stages Deployed with Dimensions

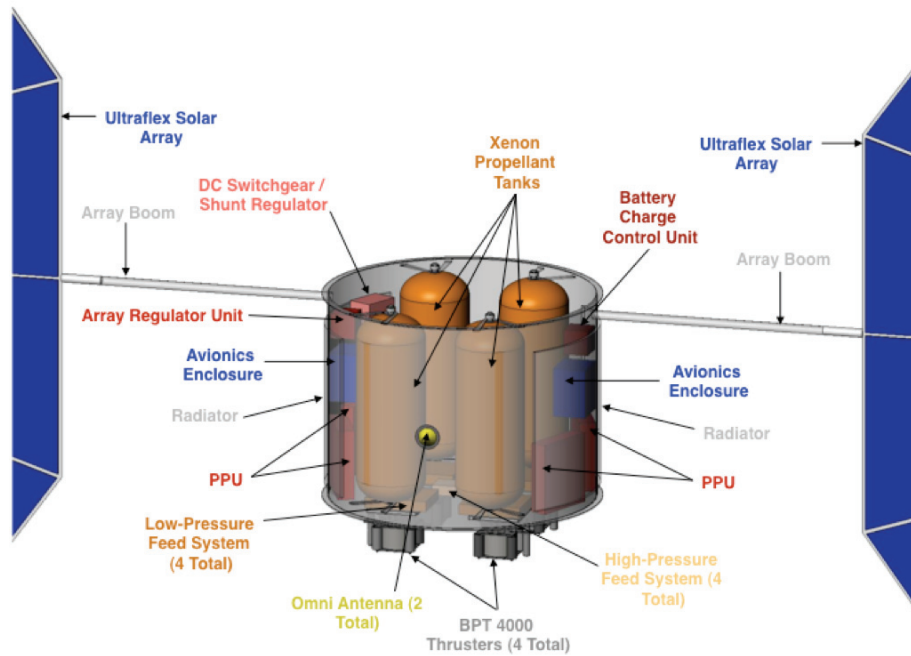

Figure 20. MERV Dedicated SEP Stage Component Locations

Components that are located external to the bus structure include the Ultraflex SA, radiators, omni antennas, and the BPT 4000 thrusters and associated gimbals. The Ultraflex SA are positioned on long booms located on opposite sides of the bust structure and have a single axis gimbal capability. The long booms are required to allow for stowage within the fairing using a single deployment mechanism located on the boom near the arrays. The radiators are located on the array sides of the bus to minimize the impact of the Sun on their heat rejection capabilities, thus minimizing the required radiator area and mass. Two omni antennas are located 180° from each other and 90° from the array boom locations. This placement reduces the interference the arrays may have on the omni antenna signal. Finally, the four BPT 4000 thrusters, and their gimbals, are mounted on the bottom of the S/C, providing thermal isolation from other subsystem components.

The components contained within the dedicated SEP stage bus include the avionics, PPU's, propellant feed systems, propellant tanks, and some of the electrical power subsystem components. The four PPU's, one for each thruster, are mounted directly to the thrust tube bus structure. They are positioned with two PPU's on each of the radiator sides of the bus, minimizing the heat transfer distance, and in the lower portion of the bus structure, maintaining a close proximity to the BPT 4000 thrusters. Also, located on each of the radiator sides of the bus structure, to maintain a close proximity to the radiators, are each of the two avionics enclosures, the battery charge control unit, the array regulator unit, and the DC switchgear/shunt regulator. Each of these components is mounted directly to the thrust tube bus structure. Structural members tied back into the thrust tube bus structure mount the four Xe tanks at their polar bosses. The low-pressure feed systems, a total of four, are mounted on the floor of the SEP stage directly above each of the four BPT 4000 thrusters, and below each of the four Xe tanks. The high-pressure feed system is also mounted to the floor of the SEP stage directly in the center of the tanks and thruster formation.

The return stage bus structure, similarly to the SEP stage, employs a thrust tube design for internal mounting of subsystem components, and to reduce the overall structure mass. The diameter of the design of the retained portion of the chemical return stage thrust tube was equal to the SEP stage thrust tube and contains a flange at the base of the structure to allow mating of the two stages. Figure 19 shows the SEP stage and all the mission specific components contained on the stage.

Components located externally to the return stage bus structure include the sample capture mechanism, sample entry capsule, fixed high-gain antenna (HGA), UHF helix antenna, four omni antennas, and radiators. The radiators are located 180° from each other on the outside of the bus and located on the same sides as the SEP stage Ultraflex SA to minimize the impact of the Sun on their heat rejection capabilities. Power for the return stage is provided by the Ultraflex SA contained on the dedicated SEP stage. The HGA is mounted on the side of the bus structure 90° from the arrays and radiators. The UHF helix antenna is located on the same side as the HGA and directly below it. Pointing of both antennas will be achieved by adjusting the S/C attitude to the proper orientation when communication is necessary. Two of the omni antennas are mounted 180° apart from each other on the top of the stage and angled 45° from the stage centerline. The other two omni antennas are located on the bottom of the stage, 180° from each other, again angled 45° from the vehicle centerline, and approximately 90° from the two located on the top of the stage. These locations provide maximum coverage for the omni antennas. The sample capture mechanism is located on the top of the return stage, a location that provides an unobstructed field of view for the cameras during rendezvous with the sample. Finally, the Earth entry capsule is located on opposite of the high gain antenna and near the top of the S/C to maintain a close proximity to the capture mechanism, thus minimizing the size required for the sample processing device.

All the avionics, GN&C, electrical power, RCS tanks, and communications boxes are contained within and mounted directly to the thrust tube bus structure, with a few exceptions. The sample processing unit is located within the bus structure at the top of the S/C, and is mounted directly to the top panel of the S/C. The star tracker sensor heads are mounted directly to the thrust tube, but protrude out of the thrust tube to allow for unobstructed viewing. They are located below the Earth entry capsule, opposite from the HGA to allow viewing of deep space while communications occur. They are oriented so that the field of view for each is 90° from one another and perpendicular to the vehicle centerline to eliminate a view of the Sun. The four momentum/reaction wheels are located along the bottom of the stage 90° from each other, but are not directly mounted to the thrust tube wall, thus requiring additional structure for mounting. The wheels are oriented such that they form a rectangular pyramid (each wheel's centerline is 45° from the vehicle centerline). Finally, the wide and narrow angle cameras used during rendezvous are mounted directly to the interior wall of the thrust tube, but protrude out the top of the S/C to provide an unobstructed view of the sample and capture mechanism during sample rendezvous. Figure 21 shows the locations and orientations of all the components on the return stage for Case 2.

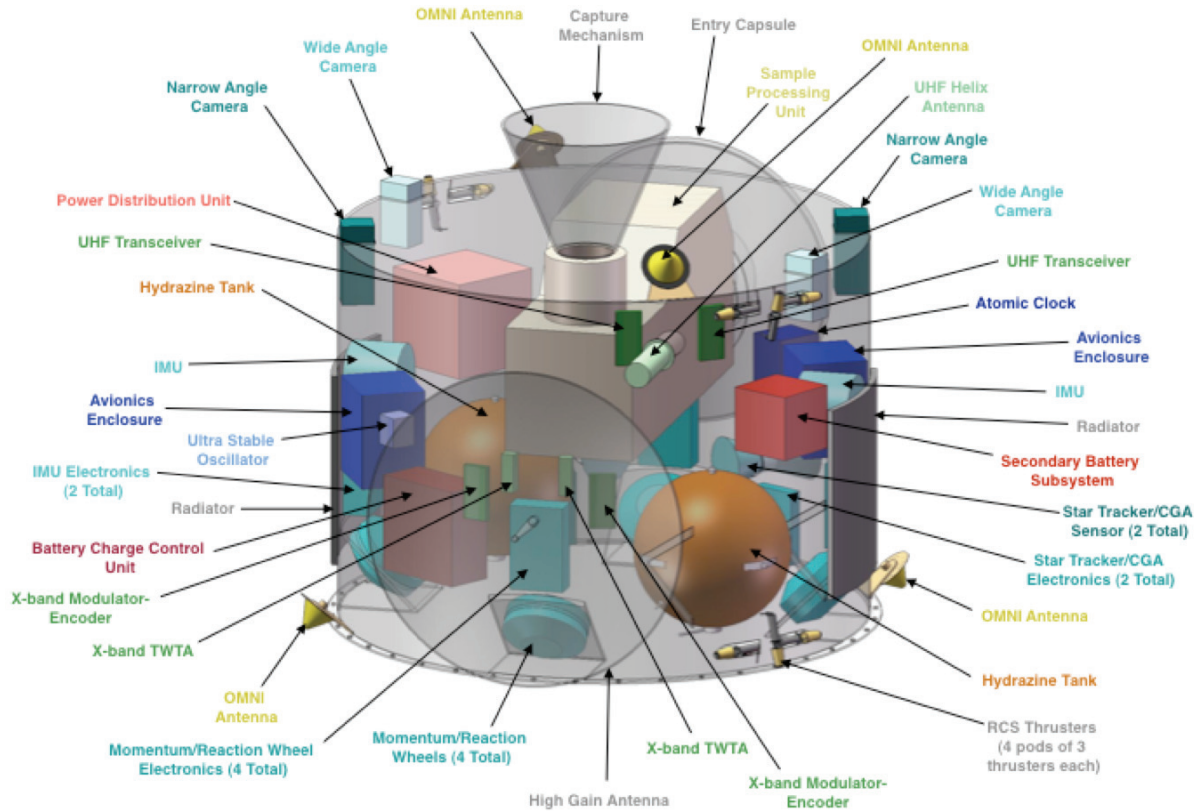

Figure 21. MERV Case 2 Return Stage Components Locations

III. Baseline Design (Case 4—One AMBR—All Chem With AB)

The MERV vehicle for the all chemical case with aero braking is composed of only one main stage: The Return Stage MEL (WBS 06) is used to size the vehicle that that performs the mission returning to Earth from Mars, specifically the MOI burn, brings the Mars sample back to Earth, and performs the TEI burn. The components used in aerobraking are contained in the power, thermal and the structures portions of the MEL. *The ‘One AMBR’ nomenclature refers to the use of a single AMBR engine for all propulsive maneuvers, a second AMBR engine is carried as a spare.*

A. Top Level Design (MEL and PEL)

1. Master Equipment List (MEL)—Return Stage (Case 4—One AMBR—Baseline 2)

Table 15. CASE 4—One AMBR MEL

| WBS | Description | QTY | Unit Mass | Basic Mass | Growth | Growth | Total Mass |
|--------|---|-----|-----------|----------------|--------|--------|------------|
| Number | Earth Return Vehicle (March 2009) -Case 4 1AMBR | | (kg) | (kg) | (%) | (kg) | (kg) |
| 06 | MERV Sample Return Spacecraft | | | 3358.11 | 4.6% | 154.10 | 3512.21 |
| 06.1 | Sample Collection Device | | | 62.00 | 23.4% | 14.50 | 76.50 |
| 06.2 | Spacecraft Bus | | | 3296.11 | 4.2% | 139.60 | 3435.71 |
| 06.2.1 | Attitude Determination and Control | | | 58.40 | 19.1% | 11.18 | 69.58 |
| 06.2.2 | Command and Data Handling | | | 35.88 | 19.2% | 6.90 | 42.78 |
| 06.2.3 | Communications and Tracking | | | 44.00 | 20.0% | 8.80 | 52.80 |
| 06.2.4 | Electrical Power Subsystem | | | 49.00 | 32.4% | 15.90 | 64.90 |
| 06.2.5 | Thermal Control (Non-Propellant) | | | 41.96 | 16.0% | 6.69 | 48.65 |
| 06.2.6 | Propulsion | | | 236.23 | 17.1% | 40.50 | 276.73 |
| 06.2.7 | Propellant | | | 2582.51 | 0.0% | 0.00 | 2582.51 |
| 06.2.8 | Structures and Mechanisms | | | 248.13 | 20.0% | 49.63 | 297.76 |

2. Power Equipment List (PEL)—Return Stage (Case 4—One AMBR—Baseline)

The power system tracks its own power and must provide: ~750 W during trajectory correction maneuvers.

The maximum thermal waste heat generated by the operations of the S/C is ~300 W. This number is used to size components in the thermal subsystem.

Table 16. Case 4—One AMBR Engine Power Estimates (Launch 2024)

| Waste Heat | Duration | Propulsion, W | Avionics, W | Comm., W | Thermal, W | GN&C W | Power, W | Science, W | SEP Stage, W | CBE Total, W | 30 % Margin, W | Total, W |
|---------------------------------|-------------------|------------------|----------------|-------------|---------------|-----------|-------------|---------------|-----------------|-----------------|----------------------|-------------|
| Launch | 10 min | 240 | 61 | 0 | 8 | 92 | 0 | 0 | 8 | 410 | 123.1 | 534 |
| Launch Vehicle Escape Injection | 10 min | 240 | 61 | 85 | 8 | 15 | 0 | 0 | 8 | 418 | 125.4 | 544 |
| Checkout | 24 hr | 240 | 61 | 85 | 8 | 115 | 0 | 15 | 8 | 533 | 159.9 | 693 |
| In Flight Ops (RCS) | 1 yr | 240 | 61 | 0 | 8 | 15 | 0 | 2 | 8 | 335 | 100.5 | 436 |
| Capture | 20 min | 240 | 61 | 85 | 8 | 92 | 0 | 2 | 8 | 497 | 149.2 | 647 |
| Aerobraking Coast | 6 months | 240 | 61 | 85 | 8 | 92 | 0 | 2 | 8 | 497 | 149.2 | 647 |
| Aerobraking Maneuvers | 20 min/2 hr orbit | 317 | 61 | 0 | 8 | 92 | 0 | 0 | 8 | 487 | 146.2 | 634 |
| Mars Orbit Loiter | 3 months | 240 | 61 | 85 | 8 | 15 | 0 | 2 | 8 | 420 | 126.0 | 546 |
| Rendezvous w/ sample (RCS) | 20 min/2 hr orbit | 317 | 61 | 0 | 8 | 92 | 0 | 0 | 8 | 487 | 146.2 | 634 |
| Sample Return TEI Burn | 40 min | 317 | 61 | 0 | 8 | 92 | 0 | 2 | 0 | 481 | 144.3 | 625 |
| Sample Return Coast | 9.7 months | 317 | 61 | 0 | 8 | 92 | 0 | 15 | 0 | 494 | 148.2 | 642 |
| Sample Return TCM | 5 min | 317 | 61 | 85 | 8 | 92 | 0 | 15 | 0 | 579 | 173.7 | 753 |
| Sample Release | 20 min | 240 | 61 | 95 | 8 | 92 | 0 | 15 | 0 | 512 | 153.6 | 666 |
| Disposal | 10 min | 240 | 61 | 85 | 8 | 92 | 0 | 2 | 0 | 489 | 146.7 | 636 |

| Waste Heat | Duration | Propulsion | Avionics | Comm. | Thermal | GN&C | Power | Science | SEP Stage | CBE Total | 30 % Margin, W | Total |
|---------------------------------|-------------------|------------|----------|-------|---------|------|-------|---------|-----------|-----------|-------------------|-------|
| Launch | 10 min | 12 | 61 | 0 | 0 | 92 | 0 | 0 | 0 | 166 | 49.8 | 216 |
| Launch Vehicle Escape Injection | 10 min | 12 | 61 | 43 | 0 | 15 | 0 | 0 | 0 | 131 | 39.4 | 171 |
| Checkout | 24 hr | 12 | 61 | 43 | 0 | 115 | 0 | 1 | 0 | 232 | 69.6 | 301 |
| In Flight Ops (RCS) | 1 yr | 12 | 61 | 0 | 0 | 15 | 0 | 0 | 0 | 89 | 26.6 | 115 |
| Capture | 20 min | 12 | 61 | 43 | 0 | 92 | 0 | 0 | 0 | 209 | 62.6 | 271 |
| Aerobraking Coast | 6 months | 12 | 61 | 43 | 0 | 92 | 0 | 0 | 0 | 209 | 62.6 | 271 |
| Aerobraking Maneuvers | 20 min/2 hr orbit | 16 | 61 | 0 | 0 | 92 | 0 | 0 | 0 | 170 | 51.0 | 221 |
| Mars Orbit Loiter | 3 months | 12 | 61 | 43 | 0 | 15 | 0 | 0 | 0 | 131 | 39.4 | 171 |
| Rendezvous w/ sample (RCS) | 20 min/2 hr orbit | 16 | 61 | 0 | 0 | 92 | 0 | 0 | 0 | 170 | 51.0 | 221 |
| Sample Return TEI Burn | 40 min | 16 | 61 | 0 | 0 | 92 | 0 | 0 | 0 | 170 | 51.0 | 221 |
| Sample Return Coast | 9.7 months | 16 | 61 | 0 | 0 | 92 | 0 | 1 | 0 | 171 | 51.2 | 222 |
| Sample Return TCM | 5 min | 16 | 61 | 43 | 0 | 92 | 0 | 1 | 0 | 213 | 63.9 | 277 |
| Sample Release | 20 min | 12 | 61 | 48 | 0 | 92 | 0 | 1 | 0 | 214 | 64.3 | 279 |
| Disposal | 10 min | 12 | 61 | 43 | 0 | 92 | 0 | 0 | 0 | 209 | 62.6 | 271 |

B. System Level Summary—Case 4—One AMBR

Case 4—One AMBR used the single MERV MEL to track all of the components that went into the design of this MERV S/C instance. The SEP stage MEL was not used in this case. So, the summary of total mass, etc., came from only WBS line items 06.1 and 06.2.

Table 17. Case 4—One AMBR Engine System Summary

| Spacecraft Master Equipment List Rack-up (Mass) - ERV | | | | COMPASS S/C Design | |
|---|--|-------------------------|--------------------|------------------------|----------------------|
| WBS | Main Subsystems | Basic Mass (lkg) | Growth (kg) | Total Mass (kg) | Aggregate Growth (%) |
| 06 | MERV Sample Return Spacecraft | 3358.1 | 154.1 | 3512.2 | |
| 06.1 | Sample Collection Device | 62.0 | 14.5 | 76.5 | 23% |
| 06.1.1.a | Sample Collection Mechanism | 20 | 4 | 24.0 | 20% |
| 06.1.1.b | Sample Capsule | 39 | 9.75 | 48.8 | 25% |
| 06.1.1.c | Sample Separation Mechanisms | 3 | 0.75 | 3.8 | 25% |
| 06.2 | Spacecraft Bus | 3296.1 | 139.6 | 3435.7 | |
| 06.2.1 | Attitude Determination and Control | 58.4 | 11.2 | 69.6 | 19% |
| 06.2.2 | Command and Data Handling | 35.9 | 6.9 | 42.8 | 19% |
| 06.2.3 | Communications and Tracking | 44.0 | 8.8 | 52.8 | 20% |
| 06.2.4 | Electric Power | 49.0 | 15.9 | 64.9 | 32% |
| 06.2.5 | Thermal Control | 42.0 | 6.7 | 48.7 | 16% |
| 06.2.6 | Propulsion | 236.2 | 40.5 | 276.7 | 17% |
| 06.2.7 | Propellant | 2582.5 | | 2582.5 | |
| 06.2.8 | Structures and Mechanisms | 248.1 | 49.6 | 297.8 | 20% |
| | Estimated Spacecraft Dry Mass | 776 | 154 | 929.7 | 20% |
| | Estimated Spacecraft Wet Mass | 3358 | 154 | 3512 | |
| System Level Growth Calculations | | | | | Total Growth |
| | Dry Mass Desired System Level Growth | 776 | 233 | 1008.3 | 30% |
| | Additional Growth (carried at system level) | | 79 | | 10% |
| | Total Wet Mass with Growth | 3358 | 233 | 3590.8 | |
| | | Basic Mass (lkg) | Growth (kg) | Total Mass (kg) | |
| | Total Spacecraft Wet Mass | 776 | 233 | 3590.8 | kg |
| | Available Launch Performance to C3 (kg) | | | 4000.0 | kg |
| | ELV Launch Margin (kg) | | | 10.0 | % |
| | ELV Launch Margin (%) | | | 400.0 | kg |
| | Available Launch Performance to C3 (kg) (after ELV margin) | | | 3600.0 | kg |
| | Additional Launch margin available (kg) | | | 9.2 | kg |
| | Additional Launch margin available (%) | | | 0.3 | % |
| | Total Launch Margin (kg) | | | 409.2 | kg |
| | Total Launch Margin (%) | | | 10.2 | % |

Note that in Table 18, there is no value input for the ELV adaptor. During the course of the design, it was decided that the adaptor from the ELV to the S/C would be taken out of the 10% performance margin and not taken from the S/C mass allocation.

Table 18. Case 4—One AMBR Architecture Details

| Architecture Details | Mass |
|--|---------------------------------------|
| Launch Vehicle | Ariane |
| ELV Performance to C ₃ Target | 4000.0 kg |
| ELV Margin (Percent) | 10.0 % |
| ELV Margin (Mass) | 400.0 kg |
| ELV Performance After Margin | 3600 kg |
| Spacecraft Adaptor To ELV Mass | 0 kg |
| ELV Performance After Adaptor | 3600 kg |
| ELV Margin After Adaptor | 0.3% |
| C ₃ Targeted | 13.00 km ² /s ² |
| Mission Total Trip Time to Mars | 457 d |
| Mission Time, Spiral At Mars | 226.0 d |
| Science Payload Delivered | 76.50 kg |
| SC Wet Mass w/ System Growth | 3591 kg |
| Total Launch Margin Available | 10.2 % |

C. Design Concept Drawing and Description—Case 4—One AMBR

The Case 4 (one AMBR Engine) design for the MERV is comprised of an all-chemical stage that performs aerobraking to help achieve Mars orbit. Figure 22 shows the entire vehicle fully deployed in its aerobraking configuration while Figure 24 shows a close-up of the S/C bus.

The primary structure is comprised of a thrust tube that is designed to mate directly to the metallic PAF and utilize the standard separation system contained on the PAF. Use of a thrust tube design with the same diameter as the PAF interface allowed the structure mass to be minimal while providing sufficient internal volume to house the subsystem components, mount those components directly to the thrust tube structure, and handle the launch loads. All components contained in the S/C are shown in Figure 25.

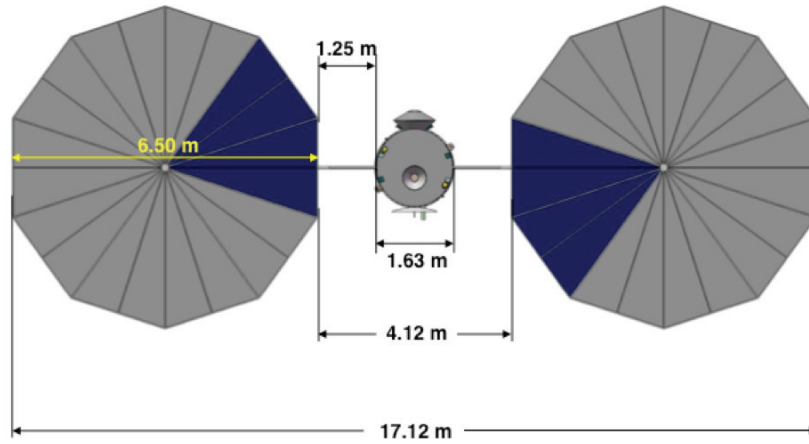

Figure 22. MERV Case 4—AMBR—Deployed Dimensions

Components that are located external to the bus structure include the Ultraflex SA/drag flaps, radiators, omni antennas, the sample capture mechanism, sample entry capsule, fixed HGA, UHF helix antenna, and the AMBR thrusters.

The Ultraflex SA/drag flaps are positioned on long booms located on opposite sides of the bus structure and have a single axis gimballed capability. The long booms are required to allow for stowage within the fairing using a single deployment mechanism located on the boom near the arrays. Because the arrays are necessary to perform the aerobraking maneuver and provide the drag in the atmosphere necessary to slow down the S/C, the area is also used to provide real estate for power, rather than carrying additional batteries. The Ultraflex SA are sized to obtain the required reference area to perform the aerobraking maneuver in the desired time, while the power requirements only need an array area equal to 1/5 of the full area available, thus only 4 of the 20 sections per array are populated with solar cells.

The radiators are located on the array sides of the bus to minimize the impact of the Sun on their heat rejection capabilities, thus minimizing the required radiator area and mass.

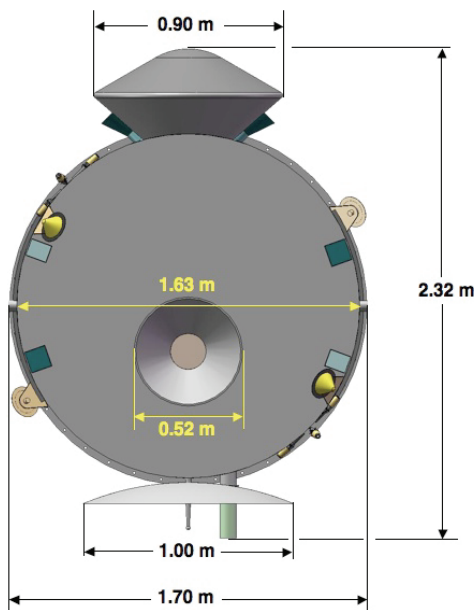

Figure 23. MERV Case 4—AMBR—Bus Side Dimensions

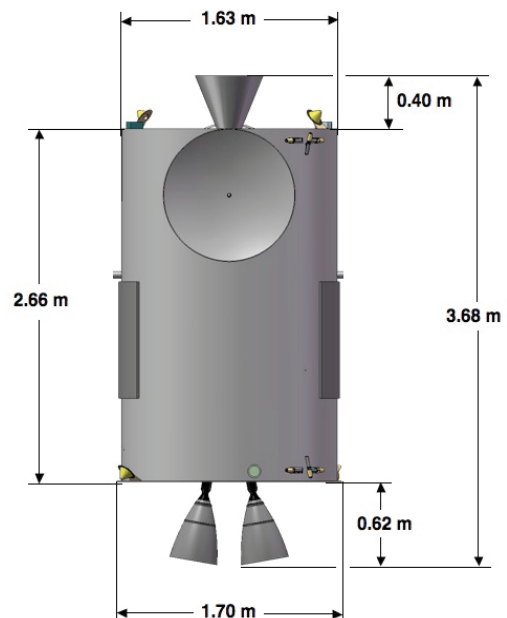

Figure 24. MERV Case 4—AMBR—Bus Dimensions (2)

Two omni antennas are located on top of the bus structure, 180° from each other, while the other two omni antennas are located on the bottom of the bus, again 180° from each other. All four of the omni antennas are angled slightly away from the upper and lower faces of the bus and at locations around the perimeter to help minimize any interference from other externally mounted components.

The HGA is mounted on the side of the bus structure 90° from the arrays and radiators, while the UHF helix antenna is located on the same side as the HGA and directly below it. Pointing of both antennas will be achieved by adjusting the S/C attitude to the proper orientation when communication is necessary.

The sample capture mechanism is located on the top of the bus structure, a location that provides an unobstructed field of view for the cameras during rendezvous with the sample, while the Earth entry capsule is located on the opposite side as the high gain antenna and near the top of the S/C to maintain a close proximity to the capture mechanism, thus reducing the size required for the sample processing device.

Finally, the two AMBR thrusters are mounted on the bottom of the S/C, providing thermal isolation from other subsystem components. One AMBR is a spare.

All the avionics, GN&C, electrical power, fuel and oxidizer tanks, pressurant tanks, and communications boxes are contained within and mounted directly to the thrust tube bus structure, with a few exceptions. The sample-processing unit is located within the bus structure at the top of the S/C, and is mounted directly to the top panel of the S/C. The star tracker sensor heads are mounted directly to the thrust tube, but protrude out of the thrust tube to allow for unobstructed viewing. They are located below the Earth entry capsule, opposite from the HGA to allow viewing of deep space while communications occur. They are oriented so that the field of view for each is 90° from one another and perpendicular to the vehicle centerline to eliminate a view of the Sun. The four momentum/reaction wheels are located along the bottom of the stage 90° from each other, but are not directly mounted to the thrust tube wall, thus requiring additional structure for mounting. The wheels are oriented such that they form a rectangular pyramid (each wheel's centerline is 45° from the vehicle centerline). Finally, the wide and narrow angle cameras used during rendezvous are mounted directly to the interior wall of the thrust tube, but protrude out the top of the S/C to provide an unobstructed view of the sample and capture mechanism during sample rendezvous.

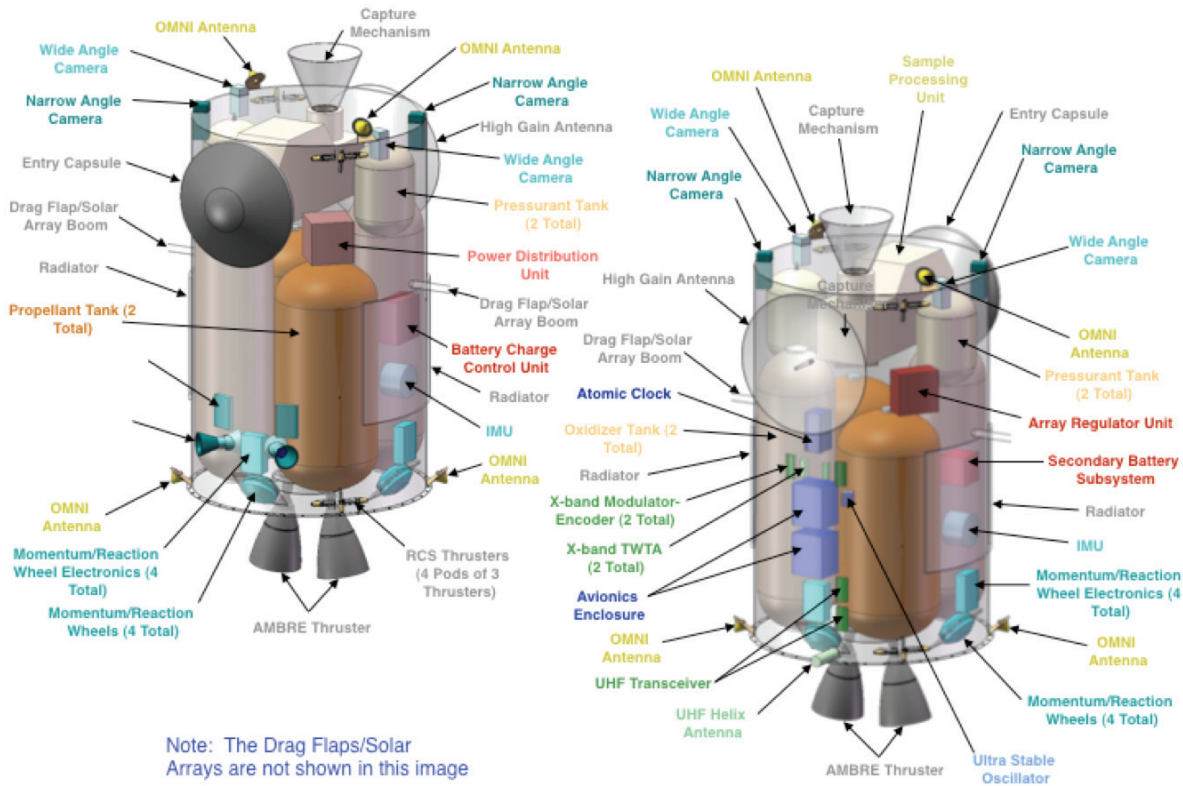

Figure 25. MERV Case 4—AMBR—Components Locations

IV. Case Summaries

The primary figure of merit for the mission has been established as reducing risk. Eliminating events (e.g., aerobraking, propulsion burns, etc.) is the primary method by which these risks can be reduced. The all-chemical case (Case 3) is extremely mass limited due to the relatively high ΔV for the mission and low Isp (333 s advanced). For the chemical cases, both staging and aerobraking were necessary areas of investigation in order to close the mission and fit within the performance of the Ariane V launch vehicle.

Cases 2 and 4—One AMBR were shown to be the most promising. Only Cases 1 and 2 would fit on Ariane 5 for 2022 opportunity. The AB/Staging Chemical stage cases only works for some of the launch opportunities considered in this launch year trade space. The all-SEP works for all opportunities, and allows for much larger launch windows.

Table 19. MERV Case 2 Versus Case 4 Top Level Summary

| GLIDE Case name | Launch Vehicle | C ₃ (km ² /s ²) | Performance to C ₃ (kg) | Total Wet Mass Outbound Stage (kg) | Total Wet Mass Return Stage (kg) | Total Launch Wet Mass (kg) | Launch Margin (kg) | Launch Margin (%) | Launch Year |
|-------------------|----------------|---|------------------------------------|------------------------------------|----------------------------------|----------------------------|--------------------|-------------------|-------------|
| MERV_Case1 | Ariane V | 9.1 | 4181 | 1958 | 1796 | 3754 | 427 | 10.2 | 2022 |
| MERV_Case2 | Ariane V | 15.6 | 3667 | 2701 | 596 | 3297 | 369 | 10.1 | 2022 |
| MERV_Case3 | Ariane V | 10.4 | 5000 | 0 | 5701 | 5701 | -701 | -14.0 | 2022 |
| MERV_Case3_drop | Atlas 551 | 15.0 | 4500 | 0 | 3712 | 3712 | 788 | 17.5 | 2022 |
| MERV_Case3_drop2 | Atlas 551 | 15.0 | 4800 | 0 | 4745 | 4745 | 55 | 1.1 | 2022 |
| MERV_Case4 | Ariane V | 13.0 | 4000 | 3148 | 0 | 3148 | 852 | 21.3 | 2024 |
| MERV_Case4_drop | Ariane V | 13.0 | 4000 | 1416 | 1883 | 3298 | 702 | 17.5 | 2024 |
| MERV_Case4_1AMBR | Ariane V | 13.0 | 4000 | 3591 | 0 | 3591 | 409 | 10.2 | 2024 |
| MERV_Case4_engine | Ariane V | 13.0 | 4000 | 3721 | 0 | 3721 | 279 | 7.0 | 2024 |
| MERV_Case4_2022 | Delta IV H | 15.0 | 7000 | 4642 | 0 | 4642 | 2358 | 33.7 | 2022 |

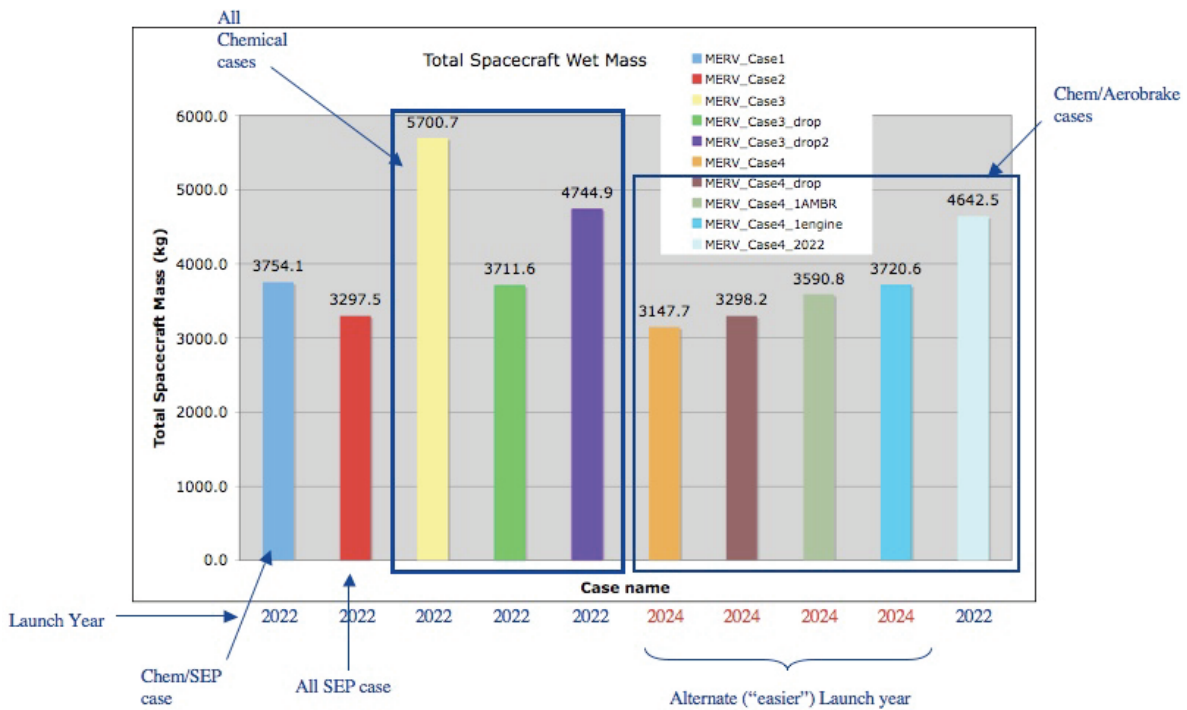

Figure 26. MERV Total S/C Wet Mass Over Examined Trade Space

The desired launch year for the MERV trade space was 2022. Some of the aerobraking cases could not be closed in that year due to high delta V and declination burns necessary to get into the Mars orbit. The “better” launch opportunity of 2024 was chosen to close those cases. Figure 26 shows the groupings of cases run during this design study. The all-chemical cases (Case 3x) were all run for the desired launch year of 2022. None of these cases fit onto the Ariane V performance even with staging and dropping mass in Mars orbit. The box around the chem/aerobrake cases was those labeled in the Case 4 family. In order to fit into the performance mass of the Ariane V launch vehicle (as requested in this study), the launch year of 2024 was examined. This is an “easier” opportunity year and the total propellant to perform the in-space portion of the mission was less, bringing the total wet mass down. The only way to close the chem/aerobrake missions was to move from the desired launch year to an easier opportunity launch year (2024 over 2022). The all-SEP case and the SEP/Chemical cases (left most cases on the figure above, and not boxed) both fit inside the Ariane performance with the desired launch year of 2022.

A. Case 2 (All SEP) Comparison to Case 4—One AMBR

The final two baselined cases for this study were the all-SEP case (Case 2) and the version of the chemical/Aerobrake Case 4 family which used a single AMBR engine with an Isp of 333 s to perform the in-space portions of the mission.

The comparison of the two MEL stages for Cases 2 and 4—One AMBR are shown in **Figure 27**. They are misleading since the MELs were used to model stages differently depending on what mission events each of the stages were performing.

For Table 20, the Return Stage MEL only houses the components outside of the propulsion system for the purpose of Case 2. All of the propulsion elements, outside of any RCS system, were removed since the SEP stage was performing all of the major mission thruster events. Therefore a total mass of 596 kg for the Case 2 Return stage for the all-SEP mission does not entirely compare to the total mass of 3590 kg for the Case 4—One AMBR all-chemical aerobrake mission.

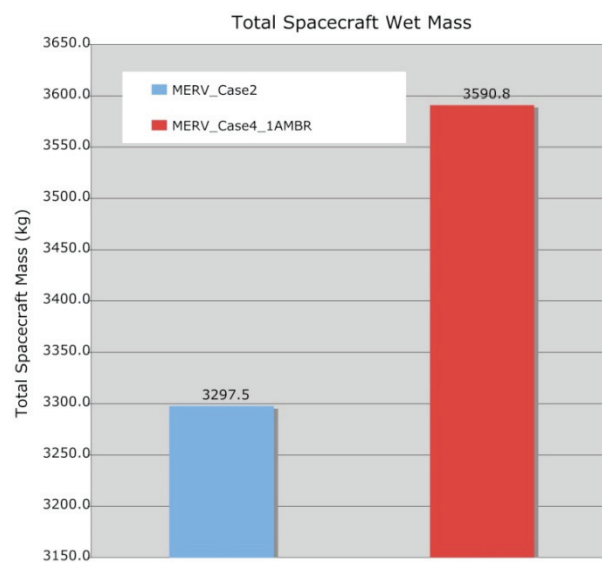

Figure 27. MERV Case 2 and Case 4 Total S/C Wet Mass

For Table 21, the SEP Stage MEL houses almost all of the major components of Case 2. All of the propulsion elements, outside of any RCS system, were located in the SEP Stage in the MEL in Table 20 since the SEP stage was performing all of the major mission thruster events. For the all-chemical Case 4—One AMBR, the SEP stage MEL was not used at all in the design. Therefore a total mass of 2700 kg for the Case 2 SEP stage for the all-SEP mission does not entirely compare to the total mass of 0 kg for the Case 4—One AMBR all-chemical aerobrake mission (See Table 21).

Combining the data in Table 20 and Table 21 yields the total mass of the vehicles from the two MELs shown above. This gives total masses that are both in the 3000s of kg. The total summary of the two vehicles is shown in Table 22. Total S/C wet mass of the all SEP case is 3297 kg, where the total wet mass of the chemical/aerobrake case is 3590 kg. Since two different launch years were assumed for these two different cases, the launch performance box into which the baseline all-SEP case fits is 3667 kg (Section II) and the launch performance for the baseline chemical/aerobrake case is 4000 kg (Section III). In each case, there is a 10% margin between the total wet mass of the vehicles and the launch vehicle performance. This means that each of these cases are considered closed and can complete the mission given the constraining parameters of launch mass and mission.

Table 20. MERV Case 2 Versus Case 4—One AMBR Top-Level Subsystem Total Masses—Return Stage

| | | GLIDE Case name | MERV_Case2 | MERV_Case 4_1AMBR |
|---|---|-----------------|-----------------|-------------------|
| | | Date | 6/12/09 | 6/29/09 |
| WBS | Main Subsystems | Total Mass (kg) | Total Mass (kg) | |
| 06 | MERV Sample Return Spacecraft | 566.0 | 3512.2 | |
| 06.1 | Sample Collection Device | 76.5 | 76.5 | |
| 06.1.1.a | Sample Collection Mechanism | 24.0 | 24.0 | |
| 06.1.1.b | Sample Capsule | 48.8 | 48.8 | |
| 06.1.1.c | Sample Separation Mechanisms | 3.8 | 3.8 | |
| 06.2 | Spacecraft Bus | 489.5 | 3435.7 | |
| 06.2.1 | Attitude Determination and Control | 69.6 | 69.6 | |
| 06.2.2 | Command and Data Handling | 42.8 | 42.8 | |
| 06.2.3 | Communications and Tracking | 52.8 | 52.8 | |
| 06.2.4 | Electric Power | 38.9 | 64.9 | |
| 06.2.5 | Thermal Control | 38.9 | 48.7 | |
| 06.2.6 | Propulsion | 60.4 | 276.7 | |
| 06.2.7 | Propellant | 136.7 | 2582.5 | |
| 06.2.8 | Structures and Mechanisms | 49.4 | 297.8 | |
| | Estimated Spacecraft Dry Mass | 429.2 | 929.7 | |
| | Estimated Spacecraft Wet Mass | 566 | 3512 | |
| System Level Growth Calculations | | | | |
| | Dry Mass Desired System Level Growth | 459.7 | 1008.3 | |
| | Additional Growth (carried at system level) | 30 | 0 | |
| | Total Wet Mass with Growth | 596.4 | 3590.8 | |

Table 21. MERV Case 2 Versus Case 4—One AMBR Top-Level Subsystem Total Masses—SEP Stage

| | | GLIDE Case name | MERV_Case2 | MERV_Case 4_1AMBR |
|---|---|-----------------|-----------------|-------------------|
| | | Date | 6/12/09 | 6/29/09 |
| WBS | Main Subsystems | Total Mass (kg) | Total Mass (kg) | |
| 07 | MERV SEP Stage | 2671.8 | 0.0 | |
| 07.1 | SEP Stage | 2671.8 | 0.0 | |
| 07.1.1 | Avionics | 16.1 | 0.0 | |
| 07.1.2 | Communications and Tracking | 1.4 | 0.0 | |
| 07.1.3 | Guidance, Navigation, and Control (GN&C) | 0.0 | 0.0 | |
| 07.1.4 | Electrical Power Subsystem | 388.3 | 0.0 | |
| 07.1.5 | Thermal Control (Non-Propellant) | 94.2 | 0.0 | |
| 07.1.6 | Structures and Mechanisms | 150.6 | 0.0 | |
| 07.1.7 | Propulsion System | 285.0 | 0.0 | |
| 07.1.8 | Propellant | 1736.2 | 0.0 | |
| | Estimated Spacecraft Dry Mass | 935.6 | 0.0 | |
| | Estimated Spacecraft Wet Mass | 2672 | 0 | |
| System Level Growth Calculations | | | | |
| | Dry Mass Desired System Level Growth | 964.9 | 0.0 | |
| | Additional Growth (carried at system level) | 29 | 0 | |
| | Total Wet Mass with Growth | 2701.1 | 0.0 | |

Table 22. MERV Case 2 Versus Case 4—One AMBR Top Level Summary

| Combined Total Spacecraft Mass (SEP Stage + Return Stage) | | |
|--|-----------------|-------------------|
| | MERV_Case2 | MERV_Case 4_1AMBR |
| | Total Mass (kg) | Total Mass (kg) |
| Total Spacecraft Wet Mass | 3297.5 | 3590.8 |
| Available Launch Performance to C ₃ (kg) | 3666.7 | 4000.0 |
| Launch Margin (%) | 10.0 | 10.0 |
| Launch margin (kg) | 366.7 | 400.0 |
| Available Launch Performance to C ₃ (kg) (after ELV margin) | 3300.0 | 3600.0 |
| Additional Launch margin available (kg) | 2.5 | 9.2 |
| Additional Launch margin available (%) | 0.1 | 0.3 |
| Total Launch margin available (kg) | 369.2 | 409.2 |
| Total Launch margin available (%) | 10.1 | 10.2 |

V. Subsystems

A. Communications

The design of the communication for the MERV with the lander is based on the system for the Mars Global Surveyor (MGS). The MGS used an ultra high frequency (UHF) communication system to communicate with an assumed Mars surface unit. One of the data rates used was at a maximum rate of 1.85 kbps. The properties of that system is repeated for the UHF system on MERV. With the following changes. The total power includes the power needed to point the UHF antenna and an increase in power needed for the communication sub-system to have redundancy.

For the communication from the MERV back to Earth, we assumed the maximum distance between the S/C and Earth is 2.5 A.U. with a maximum data rate of 1.85 kbps from a 1 m diameter X-band antenna to a 34 m antenna on Earth. The transmit power needed is only 17W. The receiver and modulator/encoder power total is 15 W. We assume that the antenna will be pointed back to Earth through the control of the attitude of the MERV itself. The requirements on the MERV S/C were the same for all cases run in this analysis.

The link budget gives an Effective Isotropic Radiated Power (EIRP) of 47.59 dB-W for transmission back to Earth. If a higher data rate is needed then the power or transmit antenna will need to be increased, or use the 70 m DSN satellite.

B. Avionics

1. Avionics Requirements

- Avionics for systems command, control, and health management
- Use of highly stable oscillators in conjunction with atomic clocks
- Communicate with GN&C to navigate, capture, and return
- Single Fault Tolerant

2. Avionics Assumptions

- Single fault tolerant avionics
- 100 kRad avionics provides operation for ~12 yr
- Cabling is estimated as ~15% of the avionics hardware
- All spares are cold spares except time generation system, automatic switchover if primary fails

3. Avionics Design and MEL

- Avionics enclosure assumes 6U-160 cPCI form factor cards.
- Rad tolerant PowerPC 750 processor for general LNS (layer 2 tunneling protocol network server) command and control.
- Power Supply with necessary DC-DC converters, filter, and EMI shielding.
- Two independent avionics strings for single fault tolerance.
- Ultra-stable oscillator (USO) Allan variance $< 10^{-13}$ /day. Stabilizes atomic clock
- Rubidium atomic clock drift nominally 5×10^{-14} /day.
- Time generation card then uses ultra-stable time signals to compute Greenwich Mean Time (GMT).

General Avionics Processor (example shown in Figure 28) performs the following functions

- System initialization
- Antenna deployment
- Antenna positioning
- SA deployment
- SA positioning
- Satellite navigation—Includes interfacing with IMUs, star trackers, and Sun sensors
- Satellite guidance
- Propulsion system control
- Systems health and status management

- Power management, control, distribution, and load



Figure 28. MERV General Avionics Processor

- shedding
- Battery regulation and management
- Thermal system management—Includes control of pumps, valves, and heaters
- System fault detection and correction
- Time synchronization via atomic clock and USO
- Time stamping
- Communication system management

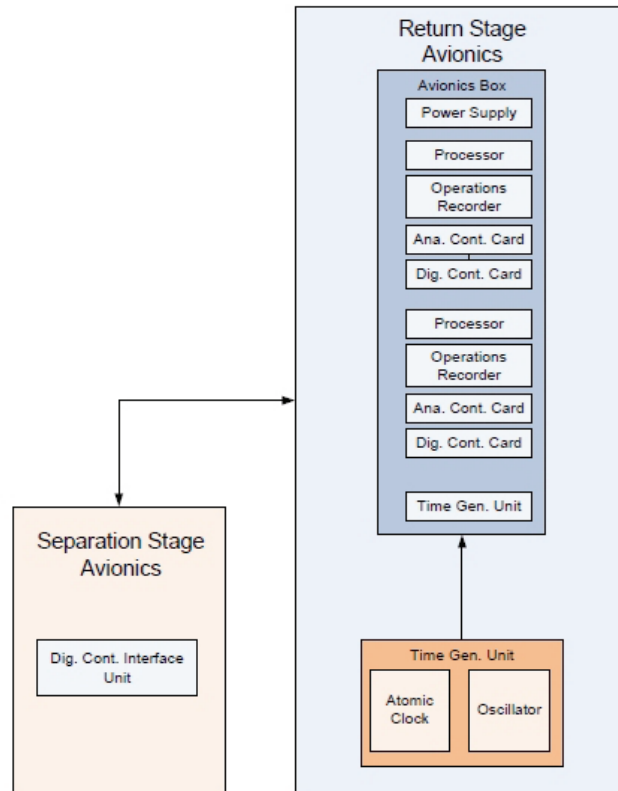

Figure 29. MERV Case 2 Avionics Flow Diagram

C. Guidance, Navigation and Control (GN&C)

1. GN&C Requirements

The GN&C system is book-kept in the MERV portion of the MELs used to model the COMPASS MERV designs. This system is the same for both the all-SEP Case 2 baseline and the chemical/AB Case 4—One AMBR baseline. The following requirements were levied on the GN&C system in all designs.

- Provide full 6 Degree of Freedom (DOF) attitude control from launch vehicle separation to end of mission
 - Interplanetary cruise
 - MOI
 - Mars orbit maintenance
 - Rendezvous and capture of the sample container
 - TEI
- Rendezvous and capture of the sample container will be 100% autonomous
- No human in the loop

2. GN&C Assumptions

Draper Inertial Stellar Compass (ISC) details

- The Draper ISC contains
 - MEMs (Microelectromechanical systems) gyros
 - Star camera
 - Microprocessor

The data from the gyro's is processed through a Kalman filter to produce an output quaternion. The star camera is used periodically to obtain a camera quaternion that enables the gyro errors to be removed. To make a camera you typically use three vectors: Position, View, and Up (X,Y,Z). Quaternions allow for the ability to mathematically rotate a vector around an arbitrary axis (same as with axis-angles). This rotational information is calculated through the use of quaternions. Quaternions are a number classification system that lends itself easily to the characterization of rotations in space.

Rendezvous and capture of the orbiting sample assumes the following items in the GN&C system. Initial knowledge of the orbit of the sample will be aided by ground ops. Orbital maneuvers are performed autonomously to rendezvous with the sample. Initial detection of the sample container is via an OpNav narrow angle camera (NAC) from MRO. A wide angle camera (WAC) flown on Mercury Surface, Space Environment, Geochemistry and Ranging (MESSENGER) will be used for close proximity operations and capture of the sample

3. GN&C Design and MEL

The GN&C system is the same on both Case 2 and Case 4. The major sections of the GN&C hardware consist of
Navigation System consists of

- Six Sun sensors
- Two narrow angle cameras, similar to the OpNav camera used on MRO
- Two wide angle cameras, similar to the wide angle camera used on MESSENGER
- Two IMUs—Honeywell MIMU
- Two Draper ISC
- One ISC includes one wide field-of-view star camera, MEMS gyros, software, and associated processing electronics

Momentum control system consists of

- Four reaction wheels with a momentum storage capability of 14 Nms each

Case 2—All SEP—MEL

WBS 06 MERV Return Stage—Case 2

All of the GN&C hardware were contained inside the Return Stage MEL in Case 2, and no hardware components of the GN&C system were book-kept in the SEP MEL.

D. Electrical Power System

1. Power Requirements

Case 2 (All SEP)

WBS 06 MERV Return Stage (Case 2)



Figure 30. Draper ISC

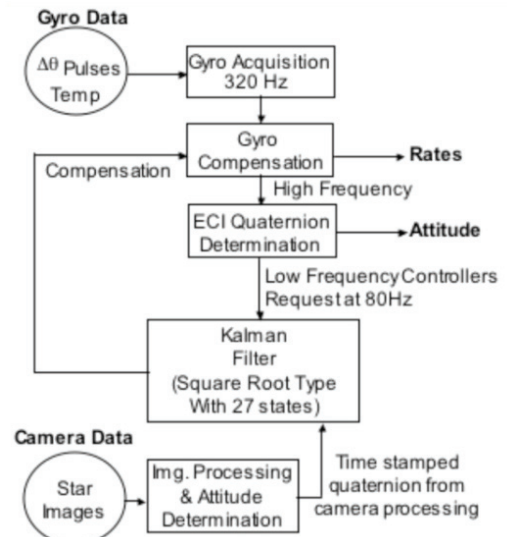

Figure 31. ISC System Data Flow Diagram

For Cases 1 and 2, the return stage obtains power from a feed through harness from the SEP stage SA and power electronics (SA regulator is on SEP stage, battery regulator and power distribution/switching is on return stage). The harness is separated into harness from SEP to return stage and harness throughout the return vehicle.

The return stage required power level with margin is 650 W at Mars orbit.

SEP Stage (Cases 1 and 2)

The SEP stage requires power of 24.4 kW at beginning of life/1 AU. Any available solar power at Mars orbit will be used for spiraling and general S/C power. The SEP stage will provide solar power to the return stage (return stage does not need separate SAs). No battery/energy storage is located on the SEP stage. SEP operation does not take place during eclipse periods.

Case 4—One AMBR—Chemical/Aerobrake

For Case 4, the mass for the solar cells/coverglass that are located on the Ultraflex drag flap are book kept under “Power,” but the Ultraflex drag flaps/gimbals are book kept under “Structures”. Power electronics for the return stage includes a SA regulator, battery regulator and power distribution/switching.

Energy storage is required for the Mars eclipse period for all return stage versions.

2. Power Assumptions

Case 2—All SEP

Whatever solar power is available at Mars (after SA degradation and solar insolation reduction with distance) is used for SEP spiraling (i.e., the SA not sized for Mars power needs, but used the 1 AU SA size determined for SEP).

Batteries are carried on the return stage and are sized for 650 W only (the SEP stage power during the Mars orbit period is only operated during illumination, the power is for the return stage only and not book kept under the SEP stage).

Two axis gimbals are assumed for the array wings based on Orion Crew Exploration Vehicle (CEV) gimbals (~800 W/kg).

A SA regulator regulates power from part of the wing and provides power to the main S/C loads except for the SEP which accepts unregulated power from most of the wing.

The Harness is divided into parts, one which goes from the SAs to the S/C and the other that goes from various loads on the S/C to the power sources.

Case 4—One AMBR—Chemical/Aerobrake

Energy storage energy density is assumed to be 100 W-hr/kg.

The maximum duration of eclipse is assumed to be 1 hr (0.7 hr for eclipse and 0.3 hr for aerobraking or other).

Power system efficiency in battery discharge mode is assumed to be 90%. Maximum depth of discharge is assumed to be 60%.

SA regulator, battery regulator, and power distribution are 130, 130, and 100 W/kg, respectively. Harness mass is based on 130 W/kg.

For the Case 4 return stage, the SA cells on the Ultraflex drag flap have a cell efficiency of 26% end of life, 493 W/m² worse case distance irradiance at Mars, 90% power system efficiency in charge mode and a solar cell only areal mass of 1.3 kg/m². One gimbal is assumed (other axis tracked based on S/C re-orientation).

3. Power Analytical Methods

The Case1, 1 and 2 SEP stage SA size (two wings at 7.7 m diameter each) is based on the 1 AU solar flux (1367 W/m²), 29% solar cell efficiency, 0.79 solar cell packing factor, 3 mil coverglass and 85% power system efficiency. Gimbal mass is based on the beginning of life SA power level divided by gimbal specific energy.

The Return stage energy storage mass is based on 650 W average user load * 1 hr storage duration/0.9 power system efficiency factor/0.6 maximum depth of discharge factor/100 W-hr/kg battery specific energy = ~12 kg. The system may be divided into two or more batteries such that in the case of one battery failing, operation during eclipse at a reduced power level is possible.

Other masses for the return stage are based on the product of the average power and the assumed specific power for that item.

The Case 4 return stage SA mass is based on the worse case incident flux at Mars orbit, SA cell efficiency of 26%, power system efficiency during charge is 90%, ~1 hr eclipse duration and 2.1 hr orbit period. The resulting area is one fifth of the area of each 6.5 m diameter Ultraflex wing. Gimbal masses are charged to structures and mechanisms.

4. Power Risk Inputs

The use of Ultraflex SA for the SEP stage that are a diameter of >7 m have not been demonstrated. Those for Constellation CEV are planned to have arrays ~5.9 m diameter. Larger arrays will have to be qualified for the

MERV program. Design does not have excess capacity for SEP. In case of failure to deploy one of two SA wings, it is unclear if the mission can be completed.

Use of Ultraflex SA wings for aerobraking has not been demonstrated. Aerobraking in past Mars S/C have been based on rigid panels. The accepted temperature ranges of Ultraflex SA materials appear above the expected temperatures to be seen during aerobraking. Also, structural loads seem within Ultraflex capability.

Energy storage should be divided into at least two batteries with operation the remaining batteries at higher depth of discharge in case of battery failure. Use of only one battery may increase the S/C risk unacceptably.

E. Structures and Mechanisms

1. Structures and Mechanisms Requirements

The design requirements for Case 1 and Case 2 of the SEP stage are similar to those of the return stage. The structure is to contain the necessary hardware for avionics, propulsion, and power. The same launch loads are imposed on the unit. Although, the return stage provides an additional load as it is mounted on top of the SEP stage.

The design requirements for Case 1 and Case 2 of the Earth return stage (the portion returning the sample to Earth) includes the ability to contain the necessary hardware for research instrumentation, avionics, communications, propulsion, and power. The structure has to bear the loads imposed by the launch vehicle while minimizing deflections, providing sufficient stiffness and vibration damping. The structure has to sustain a maximum longitudinal loading of 5g and a maximum lateral acceleration of 0.25g. Weight is to be kept to minimum. The stage has to fit within the confines of the launch vehicle.

2. Structures and Mechanisms Assumptions

The maximum longitudinal acceleration is 5g and the maximum lateral acceleration is 0.25g. It is highly desirable to keep the weight at a minimum. The size is limited by the launch vehicle compartment size. The primary structure is a thrust tube fabricated from carbon fiber reinforced epoxy using aluminum flanges. Secondary structural members are of an aluminum tubular configuration.

For All Cases

- Sizing for packaging of instruments
 - Propellant tank mounted within thrust tube
 - Instruments on interior panels
- Architecture and sizing based on heritage design
- Size of thrust tube to match launch vehicle adaptor
- Installation hardware mass, 4% of mounted unit mass

For Case 2—All SEP

- Thrust tube to bear majority of structural loads
 - Weight ERV: 1716 kg, Weight SEP: 1496 kg
 - Acceleration: 5 g
 - Thrust tube axial stress: 23 MPa
 - Lateral Acceleration: 0.2
 - Thrust tube bending stress: 1 MPa

For Case 4—One AMBR

- Thrust tube to bear majority of structural loads
 - Weight: 1716 kg, Acceleration: 5 g
 - Thrust tube axial stress: 15 MPa
- Aerodrag panel for breaking maneuver

3. Structures and Mechanisms Design and MEL

Case 2—All SEP—MEL

The return stage consists of a main thrust tube as the primary structure. The thrust tube material is to be carbon fiber reinforced epoxy in order to minimize weight. Secondary structures consist primarily of aluminum square tubular members. Welded and threaded fastener assembly is used.

Hardware mounting components masses were calculated by using four percent of the hardware mass. This was the approach used throughout the study. The total mass of the structures and mechanisms for the Cases 2 MERV and SEP stages as organized in the MEL are as follows.

- Case 2 ERV = 51 kg

- Case 2 SEP stage = 150 kg
- The Case 2 ERV thrust tube would be loaded at 32 kPa and the Case 2 SEP would be loaded to 121 kPa. The thrust tube axial stress for Case 2: 186 kPa (including 1.5 sf).

Figure 32 illustrates Case 2 with a transparent view of the return and SEP stages. The thrust tube bears the majority of structural loads. The major components of the structural design are as follows.

- Case 4—One AMBR total weight: 147 kg
- Thrust tube axial stress: Case 4 One AMBR: 320 kPa (incl. 1.5 sf)
- Aerodrag panel for drag orbit circularization maneuver: Two at 60 kg each.

4. Structures and Mechanisms Trades

Structures were designed as necessary to meet the trade space.

- Staging and the additional structure necessary to make staging possible
- Aerobraking components
- All SEP structure as different from a chemical system

5. Structures and Mechanisms Analytical Methods

Preliminary structural analysis was performed for the designs using given launch loads.

- Analytical Assumptions
- Material: Aluminum / composites
- Thrust tube
- Square tubular members
- Welded and threaded fastener assembly

The Case 2, all-SEP, thrust tube structure is shown in Figure 33.

Case 4, chemical/aerobrake, thrust tube structure is shown in Figure 33. In addition to the thrust tube, the other major component of the structure was the drag flaps. In order to brake into the lower altitude circular orbit, a set of drag flaps or aerobrake panels were added to the design. These panels were sized to provide the drag necessary to slow down the S/C given its mass and volume and the properties of the Martian atmosphere. Each aero drag panel has an area of 33.2 m² with a pressure of 0.33 Pa acting on it. The resulting load is 11 kN. On the other hand, with a S/C mass of approximately 1000 kg and an engine force of 1334 N the resulting approximate acceleration is 1.33 m/s². Each panel has a mass of 59 kg, which results in an applied load of 78 N. As a result, the panel support is sized according to the load due to acceleration during peak engine operation.

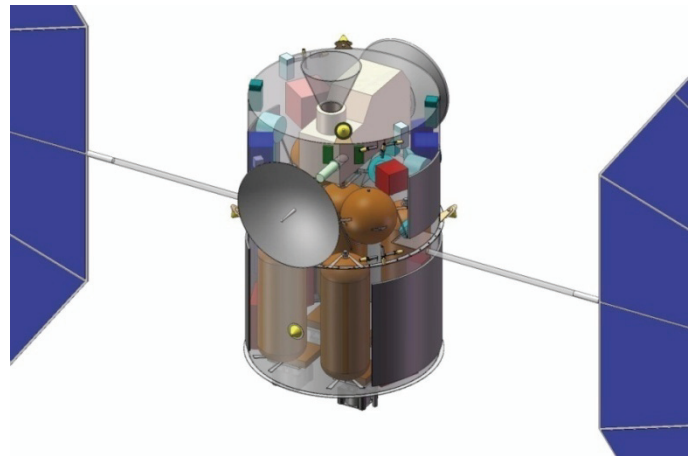

Figure 32. Case 2 All SEP Stage

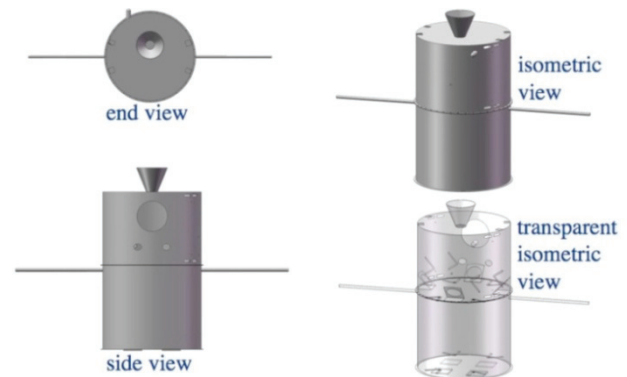

Figure 33. Case 2—All SEP Stage Isometrics Used in Structural Modeling

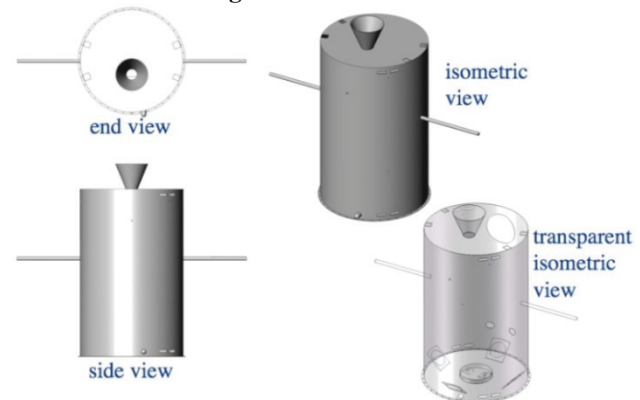

Figure 34. Case 4—One AMBR Isometrics Used in Structural Modeling

6. *Structures and Mechanisms Risk Inputs*

Potential impact with foreign object or due to nearby operations.

7. *Structures and Mechanisms Recommendation*

Assessed chemical and EP options for the ERV in the MERV design study. The most promising results were as follows.

- All SEP provides reasonable trip times, fewer critical events than chemical/ aerobraking/staging, opportunities in ‘challenging’ mission years
- Chemical/aerobrake with AMBR engines fits Ariane 5 for less challenging mission year

F. Propulsion and Propellant Management

1. *Propulsion and Propellant Management Requirements*

Both the SEP and chemical propulsion systems are required to provide primary S/C propulsion for the entire mission, store and provide adequate propellant, and provide S/C attitude control sufficient to accomplish mission objectives with some level of redundancy in both main propulsion and RCS.

Case 2—All SEP

WBS 07 SEP Stage—Case 1 and 2

The primary requirements for the SEP system are as follows:

- BPT-4000 Hall Effect Thruster using Xe propellant for primary propulsion
- Use of existing high and low pressure feed systems
- Use of existing components (tanks, lines, valves, regulators, heaters, etc.)
- Spare thruster for redundancy
- Gimbaled thrusters
- RCS system sized for adequate attitude control
- Minimum integrated system mass

For the all-chemical variant, the primary requirements are as follows:

- S/C volume compatible with launch vehicle faring
- Use of existing components (tanks, lines, valves, regulators, heaters, etc.)
- Spare thruster for redundancy
- Gimbaled thrusters
- RCS system sized for adequate attitude control
- Minimum propellant loss during entire mission
- Minimum integrated system mass

2. *Propulsion and Propellant Management Assumptions*

Case 2—All SEP

For the SEP variant, it was assumed that the Aerojet BPT-4000 Hall Effect thruster using Xe propellant would provide primary propulsion, and would utilize existing high and low pressure feed systems unique to this type of Xe based thruster. It was also assumed that the Xe would be stored under high pressure, thus no pressurant is required for the main propellant feed system. In order to reduce both risk and cost, the use of off-the-shelf components (including lines, valves, MLI, sensors, etc.) was used wherever possible.

Case 4—One AMBR

For the chemical option, preliminary calculations showed that cryogenic options yielded unacceptable tank volumes, not to mention boil-off issues. Therefore, space storable propellants were assumed for this study, with hydrazine being chosen as baseline due to engine performance. In order to reduce both risk and cost, the use of off-the-shelf components (including lines, valves, MLI, sensors, etc.) was used wherever possible.

For primary propulsion, the R-4 bipropellant engine is in the correct thrust class for this S/C, and is shown in Figure 35. Due to its performance relative to other R-4 derivatives, as shown in Table 23, the AMBR engine was selected for the main chemical propulsion system. The AMBR engine is newest version of the R4 engine family, which has an extensive history. Originally used for Apollo Lunar and Service Module Attitude Control, over 800 individual engines having been produced.

Traditional RCS layouts, propellant line runs, and operational characteristics were assumed for both configurations.

The R-4 Engine family has an extensive history. It was developed and used for Apollo Lunar and Service Module Attitude Control. The R-4 engine was first flown in 1966. Over 800 individual R-4 engines have been produced. Variants of the original R-4 engine were used on Insat 1, Arabasat 1, Milstar, Intelsat, Olympus, and Eurostar.

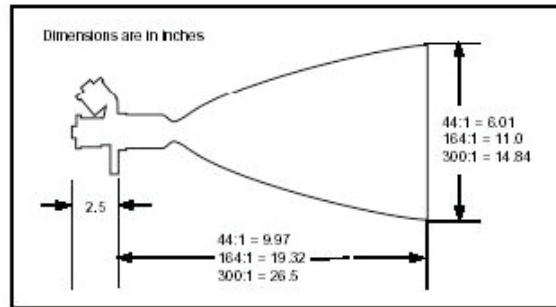

Figure 35. R-4 Engine

R-4 Engine Technical Details:

- Pressure fed with hypergolic propellants
 - Originally used monomethyl hydrazine/nitrogen tetroxide (MMH/NTO)
 - Hydrazine/NTO capable variants (AMBR)
- Envelope approx. 29 in. by 14.9 in. dia. (300:1 nozzle)
- Nominal 3.76 kg engine mass
- Aerojet solenoid valves (single coil, single seat)

Table 23 gathers the engine characteristics of the derived engines used in Case 4 in this study.

Table 23. R-4 Derived Engine Characteristics

| Characteristic | AMBR | HiPAT DM (R-4D-15DM) | HiPAT DM (R-4D-15DM) | R-4D |
|-----------------------|---------------|-------------------------|-------------------------|-------|
| Thrust (lbf) | 200 | 100 | 100 | 110 |
| ISP (s) | 335 | 328 | 328 | 315 |
| Inlet Pressure (psia) | 400 | 250 | 250 | 425 |
| Oxidizer/Fuel Ratio | 1.2 | 1.0 | 1.0 | 1.6 |
| Nozzle Area Ratio | 400:1 | 375:1 | 375:1 | 300:1 |
| Valves | From R-4D | | | |
| Propellants | Hydrazine/NTO | | MMH/NTO | |

3. Propulsion and Propellant Management Design and MEL

Case 2 WBS 07 SEP Stage Propulsion System Details

The Main Electric Propulsion Subsystem for Case 2 is comprised of:

- Four Aerojet BPT-4000 Hall Thrusters—up to three operating, one spare
- Gimbals on each thruster for thrust vector control
- Four PPU's individually mated to the thrusters (no cross-strapping)
- Four COPV Ti lined high pressure cylindrical storage tanks for the Xe propellant
- Xenon distribution system based on aerojet-developed hall thruster feed system
- Nominal set of valves, disconnects, regulators, filters, lines, tank and line insulation and heaters
- Nominal instrumentation suite of temperature and pressure sensors

The SEP propellant management system is sized to accommodate an adequate mission propellant load, which required four COPV Xe tanks which feed a single high pressure feed system assembly. This single high pressure assembly feeds 4 independent low pressure feed systems that provide propellant to each BPT-4000 Hall Effect

thruster. A schematic of the Xe system is shown in Figure 36. Only three thrusters fire at any given time, with one thruster held in reserve. All four thrusters are gimballed independently, with a single thruster shown in Figure 37.

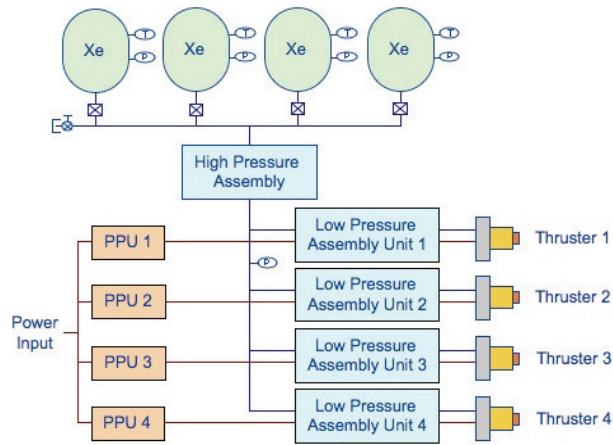

Figure 36. Case 2, All SEP Propulsion System Diagram

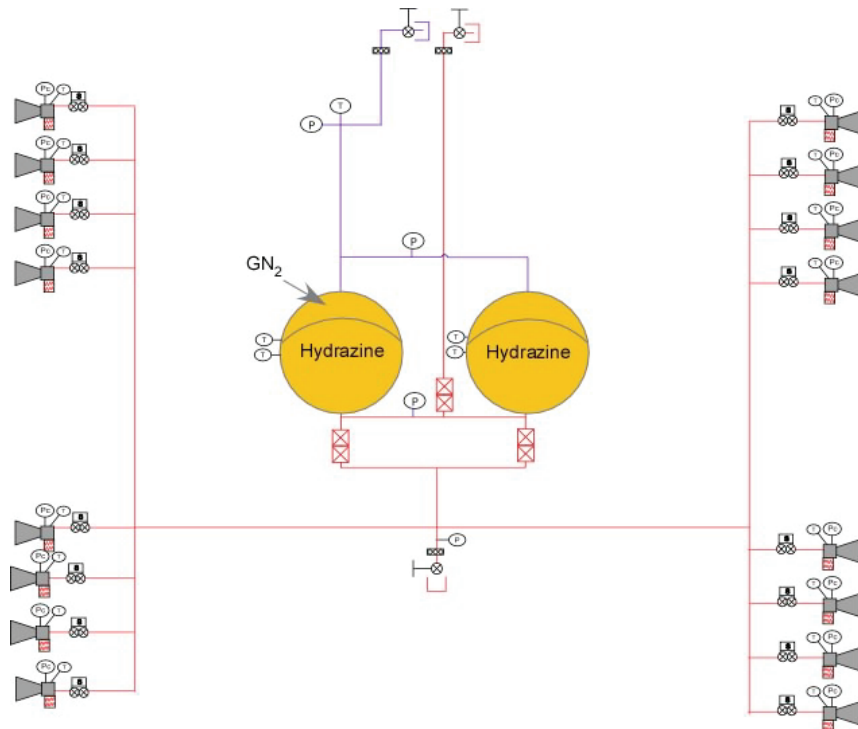

Figure 37. Case 2, RCS Propulsion System diagram.

The RCS Propulsion Subsystem on Case 2

The RCS propulsion subsystem is a nitrogen pressurized hydrazine monopropellant system operating in a blow-down type configuration. The system is comprised of the following major components:

- Sixteen 1 lbf monoprop reaction control thrusters
 - Aerojet MR-111 hydrazine thrusters
 - Isp = 229 s
 - Thrust = 4.4 N (1 lbf)
 - Thrusters require power for operation of catalytic bed

- Propellant stored in two spherical Ti metallic tanks with membrane
- Nitrogen gas pressurization
- Nominal set of valves, disconnects, regulators, filters, lines, tank and line insulation and heaters
- Nominal instrumentation suite of temperature and pressure sensors

The fuel loadings used to size the main Xe tanks and the RCS hydrazine tanks for the SEP variant is shown in Table 24. The RCS system and associated tankage and propellant are book-kept in the MERV Return Stage MEL for the purpose of sizing the All-SEP Case 2.

The propellant tanks selected for the SEP variant are based on existing models which are detailed below:

- Xenon tank derived from ATK-PSI Model No. 80458-101
 - Stock size: 0.42 m height by 0.71 m length (16.2 in. h by 40.7 in. l)
 - Internal volume = 120 liter (7,300 in.³)
 - Carbon overwrapped cylindrical tanks with Ti liner
- Hydrazine tank derived from ATK-PSI Model No. 80273-7
 - Stock size: 0.52 m diameter (20.5 in.)
 - Internal volume of 74 liter (4,500 in.³)
 - Titanium alloy 6Al-4V with polymer diaphragm
- Length changes were made to the cylindrical sections to accommodate the propellant load

Table 24. Propellant Details for Case 2 (all SEP)

| Propellant Details | |
|---|------------------|
| SEP Stage | |
| SEP Stage Nominally Used Prop Xe | 1386.0 kg |
| SEP Stage Nav. and Traj. Margin | 69.3 kg |
| Main Residuals | 49.9 kg |
| Total Main Used Xe Propellant | 1505.2 kg |
| Chemical Return Stage | |
| Return Stage Nominally Used Prop | 0.0 kg |
| Return Stage Nav. and Traj. Margin..... | 10.1 kg |
| Return Stage Main Residuals | 2.8 kg |
| Total Main Chemical Propellant | 10.1 kg |
| RCS and ACS | |
| RCS/ACS Used Prop | 100.7 kg |
| RCS/ACS Residuals (included in main) | 0.0 kg |
| RCS Total Loaded Pressurant | 0.8 kg |
| Total RCS/ACS propellant | 101.4 kg |

Case 2—All SEP

WBS 06 MERV Return Stage—Case 2

The Return Stage MEL in Case 2 contains the propellant hardware (thrusters, tanks) and propellant to run the RCS system. The RCS thruster assembly is located in line items 06.2.6.f. The associated tanks, feed lines, and pressurant for the RCS system are also located on this Return Stage MEL.

WBS 07 SEP Stage—Case 1 and 2

For Case 2, the Electric propulsion hardware (Thrusters, gimbals, tanks, feed lines, etc.) and the Xe propellant are book kept in the SEP Stage MEL.

Case 4 (One AMBR) Propulsion System Details

The Propulsion Subsystem or Case 4—One AMBR is Comprised of:

- 2 x 100 AMBR engines, based on a dual-mode HiPAT engine
- Gimbale engines firing one with one spare
- Metallic Ti fuel and oxidizer tanks
- Integrated monoprop RCS
- Carbon overwrapped pressurant tanks with Ti liner
- Mass model includes nominal valves, disconnects, regulators, tank and line insulation and heaters
- Nominal instrumentation suite of temperature and pressure sensors

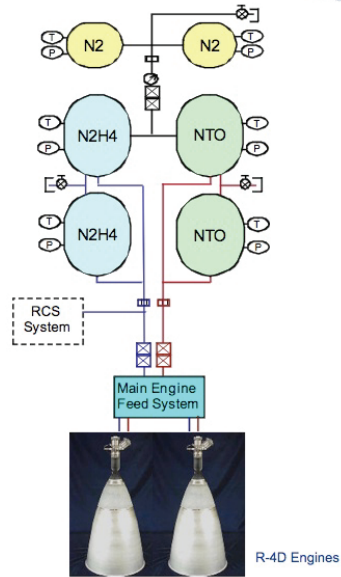

Figure 39. AMBR Propulsion System Schematic

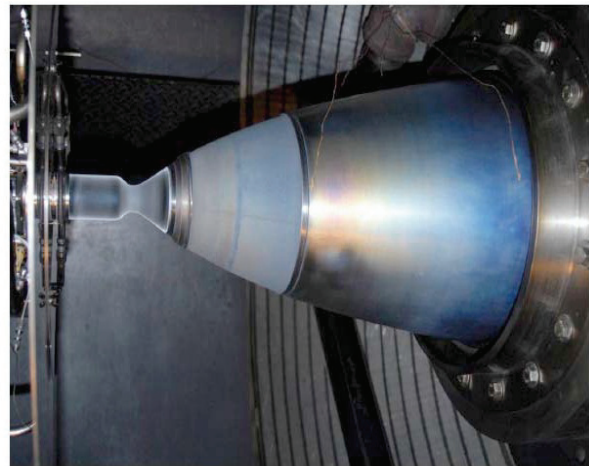

Figure 38. AMBR engine

Case 4—One AMBR

WBS 06 MERV Return Stage

For the all chemical propulsion system case, the main propulsion subsystem is comprised of two pressure fed AMBR engines, shown in Figure 38, operating on hydrazine and nitrogen tetroxide. Operationally, only one engine operates at a time, reserving the second as a spare. The feed system is pressurized via a dedicated nitrogen pressurization system, and the hydrazine feed system is integrated with the RCS. A schematic of this system is shown in Figure 39.

RCS Propulsion Subsystem of Case 4 One AMBR

The RCS subsystem is a pressure fed monopropellant system consisting primarily of 16 Aerojet MR-111 thrusters. A basic schematic is shown in Figure 40. The RCS propellant (hydrazine) storage, pressurization, and primary feed system are integrated with those of the main propulsion system in order to eliminate redundant subcomponents and subsystems, thus reducing total system mass. The major RCS system components include:

- Sixteen 1 lbf monoprop thrusters mounted in four pods
 - Aerojet MR-111 hydrazine thrusters
 - $ISP = 229$ s
 - Thrust = 4.41N (1 lbf)
 - Thrusters require power for operation of catalytic bed
- Integrated with Main Propulsion Feed System
- Nominal instrumentation suite of temperature and pressure sensors
- Model includes heater and line insulation mass

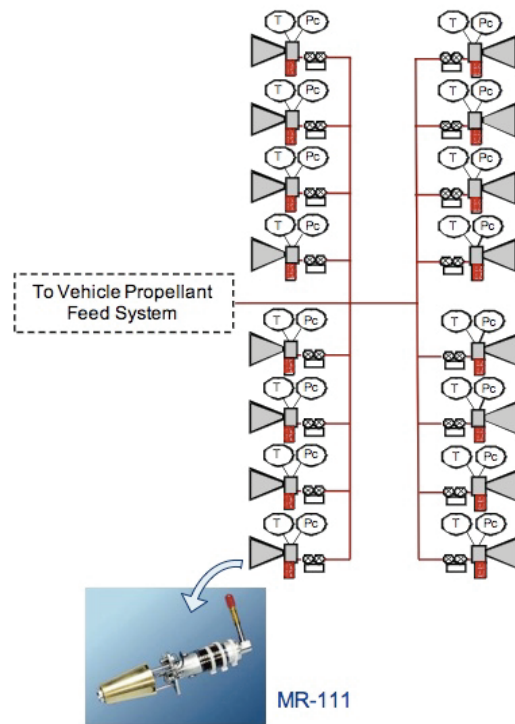

Figure 40. Case 4 RCS System Diagram

The other single engine case (Case 4_engine) we ran was the R-4D HiPAT. Both it and the AMBR are R-4 derivatives. The HiPAT motor had an ISP of 328 s, where the AMBR was higher at 333 s. The AMBR program goal is to be able to run at an Isp of 335 s.

Propellant Tanks

The propellant tanks selected for the all chemical variant include two hydrazine tanks, two nitrogen tetroxide tanks, and two nitrogen pressurant tanks. All the tanks are based on existing models which are detailed below:

- Titanium fuel tank derived from ATK-PSI Model No. 80398-1
 - Stock size: 0.72 m by 1.65 m L (28.5 in. by 55.0 in. L)
 - Internal volume = 438 liter (26,750 in.³)
 - Alloy 6Al-4V
 - Internal PMD
- Oxidizer tank derived from ATK-PSI Model No. 80435-1
 - Stock size: 0.54 m by 1.65 m L (21.3 in. by 65.0 in. L)
 - Internal volume = 432 liter (26,345 in.³)
 - Alloy 6Al-4V
 - Internal PMD
 - Carbon overwrap on cylindrical section
- Pressurant tank derived from ATK-PSI Model No. 80400-1
 - Carbon overwrapped cylindrical tanks with Ti liner
 - Stock size: 0.41 m by 0.66 m (16 in. by 26 in. L)
 - Internal volume of 67 liter (4,105 in.³)
- Length changes to cylindrical sections to match propellant load



Figure 41. ATK-PSI Derived Tank

4. *Propulsion and Propellant Management Trades*

Propulsive Element Stages/Trades Considered

- All-up vehicle (no staging or aerobraking)—not viable given trip time/mass constraints
 - No-jettisoning ‘stages’
 - Option to jettison tanks?
 - Less complex but must return all systems to Earth
- Staged ERV
 - Stage vehicle to capture at Mars (EP or chemical)
 - SEP stage for to-Mars propulsion and sample capture—provides gradual maneuvering and plenty of power for capture systems
 - Option for SEP ‘pump-up’ orbit to minimize chemical return stage requirements
 - Dumb chemical stage
 - Stage or vehicle to return to Earth (EP or chemical)
 - Chemical to provide ~1 yr desired return time
- Trade which stage to put communications components and when to drop them
- Should there be two unique relay and sample capture systems?
- More complex, unless just dropping tanks/stage, would require two vehicles—increases cost

5. *Propulsion and Propellant Management Analytical Methods*

Engine performance data was obtained from published sources, as were off-the-shelf component masses. Other component masses were determined via physics based sizing relationships or modifications to existing or similar hardware, such as modifying existing tanks. Tanks were sized based on required propellant loads, line lengths were estimated base on vehicle configuration and dimensions, and pressurant load was sized to completely empty propellant tanks, yet still maintain minimum feed pressure to both main propulsion and RCS.

6. *Propulsion and Propellant Management Risk Inputs*

Hall-effect thruster technology has a very successful flight history. The BPT-4000 design itself has successfully undergone extensive endurance testing, and is based on a series of successful flight engines, thus the risk inherent in any new engine has been greatly reduced.

Currently, AMBR engine testing is ongoing; therefore there is a risk of materials durability or endurance limit issues being discovered during testing. Due to the heritage of the engine components and propellants, this risk is minor, and at worst would result in a minor reduction of performance in the production engine.

All other propulsion system components outlined here are either currently in use with flight performance histories, or require minor modification of existing components, such as tank length being adjusted to accommodate propellant loading. Therefore, the risk associated with these components is considered small.

7. *Propulsion and Propellant Management Recommendation*

The power supplies for the Hall effect thrusters were not cross-strapped in this study, but it is recommended to assess the mass penalty of doing so in order to gain the additional system reliability.

G. Thermal Control

Objective: To provide spreadsheet based models capable of estimating the mass and power requirements of the various thermal systems. The thermal modeling provides power and mass estimates for the various aspects of the vehicle thermal control system based on a number of inputs related to the vehicle geometry, flight environment and component size. The system consists of the following elements

- Electric heaters
- MLI
- Thermal paint
- Radiator with louvers
- Thermal control system (sensors, switches, data acquisition)

1. *Thermal Requirements*

The thermal requirements for the mission were to provide a means of cooling and heating of the S/C equipment in order to remain within their maximum and minimum temperature requirements during transit and orbit insertion at Mars and for the return trip to Earth.

The S/C was broken into two segments: the outbound stage the transits from Earth to Mars and the return stage that returns from Mars to Earth. The thermal requirements are different for each of these stages. The maximum heat load on the transit stage was 1125 W and for the return stage it was 299 W. The desired operating temperature for the electronics was 300 and 250 K for the S/C structure. The S/C was required to maintain these temperature requirements at the various stages of the mission, Earth orbit, transit to and from Mars and in Mars orbit.

The aerobraking maneuver in the Case 4 family of design cases adds additional concerns to the design of the thermal control system. The S/C engine bulkhead MLI is used as the primary heat shield during the aerobraking maneuver. Shield temperature and heat transfer to S/C interior is determined through an energy balance. Radiation heat transfer to space is dependent on the shield temperature and the view factor to deep space. The Aerodynamic drag heating is dependent on the atmospheric density and S/C velocity. Heat leak through insulation to S/C interior is dependent on the number of layers of MLI.

2. *Thermal Assumptions*

The assumptions utilized in the analysis and sizing of the thermal system were based on the operational environment, including low Earth orbit (LEO) and transit to and from Mars orbit. The following assumptions were utilized to size the thermal system.

- LEO provided the worst case operating condition thermally.
- Radiator designed to see deep space with minimal view factors to the Earth or Mars surface.
- The maximum angle of the radiator to the Sun was 20°.
- The radiator temperature was 320 K.
- View factor of the radiator to the S/C SA was 0.1.
- View factor of the radiator to the Earth was 0.25
- A redundant radiator was used to account for vehicle orientation on the surface and to increase overall reliability.
- MLI was used to insulate the S/C to minimize heat transfer to and from the surroundings.
- Electric heaters and the radiator louvers were used to maintain the desired internal temperature of the S/C

3. Thermal Design and MEL

The thermal system is used to remove excess heat from the electronics and other components of the system as well as provide heating to thermally sensitive components throughout shadow periods and during deep space transit.

Excess heat is collected from a series of aluminum cold plates located throughout the interior of the S/C. These cold plates have heat pipes integrated into them. The heat pipes transfer heat from the cold plates to the radiator, which radiates the excess heat to space. The portions of the heat pipes that extend from the S/C and are integrated to the radiator are protected with a micrometeor shield. The radiator system utilizes louvers to regulate the internal temperature and to insulate the radiators during cold periods. The louvers reduce the effective radiator area by 30%.

Two radiators were used to provide redundancy and margin as well as account for the unknown orientation of the S/C throughout its mission. This added margin insures against unforeseen heat loads, degradation of the radiator due to degradation and increased view factor toward any other thermally hot body not accounted for in the analysis.

4. Thermal Analytical Methods

The analysis performed to size the thermal system is based on first principle heat transfer from the S/C to the surroundings. This analysis takes into account the design and layout of the thermal system and the thermal environment to which heat is being rejected to or insulated from. For more detailed information on the thermal analysis a summary white paper titled “Preliminary Thermal System Sizing” is being produced.

Environmental Models:

Solar Intensity Based on S/C Location components were sized for worst case operating conditions: Heat Rejection in low earth orbit and minimum temperature in deep space.

Systems Modeled:

- Micro meteor shielding on radiator
- Radiator panels
- Thermal control of propellant lines and tanks
- S/C insulation
- Avionics and Power Management and Distribution (PMAD) cooling

Table 25. Thermal System Inputs and Outputs Data Passing

| Input | Output |
|--|---|
| S/C dimensions (length, diameter) | Heat pipe length and mass |
| Power management and electronics dimensions | Cold plate size and mass |
| Waste heat load to be rejected | Radiator size and mass |
| Distance from the Sun and S/C orientation | S/C insulation mass and thickness |
| View factor to the SAs and their temperature | Thermal system components mass |
| Propellant tank dimensions and operating temperature | Propellant tanks insulation mass and heater power level |
| Propellant line lengths and operating temperature | Propellant line insulation mass and heater power level |

Radiator Sizing

The radiator panel area has been modeled along with an estimate of its mass. The model was based on first principles analysis of the area needed to reject the identified heat load to space. From the area, a series of scaling equations were used to determine the mass of the radiator within the lunar environment. An earth orbit 1 AU thermal environment was used to size the radiator.

Table 26—Thermal System Radiator Sizing Assumptions

| Variable | Value |
|--|---------|
| Radiator solar absorptivity | 0.14 |
| Radiator emissivity | 0.84 |
| Radiator Sun angle | 70° |
| Radiator operating temperature | 320 k |
| Total radiator dissipation power | 656.5 W |
| View Factor to SA | 0.10 |
| View Factor to Earth | 0.10 |
| View Factor to Moon..... | 0.25 |

Louvers are active or passive devices that regulate the amount of heat rejected by the radiator. Actively controlled louvers use temperature sensors and actuators to control the louver position. Passively controlled louvers

commonly use a bimetallic spring that opens and closes the louver based on temperature. The louver specific mass is 4.5 kg/m^2 .

Thermal Analysis Propellant Lines and Tanks

Power requirements and mass have been modeled. This modeling included propellant tank MLI and heaters and propellant line insulation and heaters.

The model was based on a first principles analysis of the radiative heat transfer from the tanks and propellant lines through the S/C structure to space. The heat loss through the insulation set the power requirement for the tank and line heaters. The 1 AU thermal environment was used to calculate the heat loss.

Thermal Analysis—S/C Insulation

Multilayer insulation was used to insulate the propellant tanks and the S/C. The insulation was sized based on a first principles analysis of the radiation heat transfer from the tanks and propellant lines to space as well as from the S/C interior to space. The heat loss through the insulation set the power requirement for the propellant tank and line heaters as well as the S/C internal heaters. The variables used to size the MLI are given in Table 27.

Table 27. Thermal System Tank Insulation Sizing Assumptions

| Variable | Value |
|--|---------------------------|
| Tank surface emissivity (ϵ_t) | 0.1 |
| MLI emissivity (ϵ_i) | 0.07 |
| MLI material | Al |
| MLI material density (ρ_i) | $2,770 \text{ kg/m}^3$ |
| Internal tank temperature (T_i) | 300 K |
| MLI layer thickness (t_i) | 0.025 mm |
| Number of insulation layers (n_i) | 10 |
| MLI layer spacing (d_i) | 1.0 mm |
| Tank immersion heater mass & power level | 1.02 kg @ up to 1,000 W |
| S/C inner wall surface emissivity | 0.98 |
| S/C outer wall surface emissivity | 0.93 |
| Line foam insulation conductivity | 0.0027 W/m K |
| Line foam insulation emissivity | 0.07 |
| Propellant line heater specific mass & power | 0.143 kg/m @ up to 39 W/m |
| Line foam insulation density | 56 kg/m^3 |

Thermal Analysis—PMAD Cooling

Thermal control of the electronics and Active Thermal Control System (ATCS) is accomplished through a series of cold plates and heat pipes to transfer the excess heat to the radiators. The model for sizing these components was based on a first principle analysis of the area needed to reject the identified heat load to space. From the sizing a series of scaling equations were used to determine the mass of the various system components.

Table 28. Thermal System PMAD Cooling Sizing Assumptions

| Variable | Value |
|--|------------------------|
| Cooling plate & lines material | Al |
| Cooling plate & lines material density | $2,770 \text{ kg/m}^3$ |
| Number of cooling plates | 4 |
| Cooling plate lengths | 0.5 m |
| Cooling plate widths | 0.5 m |
| Cooling plate thickness | 5 mm |
| Heat pipe specific mass | 0.15 kg/m |

5. Thermal Risk Inputs

Although the thermal system is mostly passive there are still components that can fail. These are the main components, which, if failure did occur, could disrupt the mission.

Radiator Louvers

If failure of the louvers did occur it would limit the heat transfer from the S/C. If the failure occurred while the louvers were closed the electronics and interior components cooled by the radiator would overheat during the illumination. If it occurred while the louvers were open excessive heat would be lost during the shadowing, significantly reducing the component temperature and possibly damaging the electronics and other systems.

Heat Pipes

If this failure occurs it would most likely lead to a failure of the electronics.

Heater

If an internal S/C heater failure occurs it could lead to the failure or degraded operation of the electronics or other components being heated component. If the heater was in the propellant tank or lines it could lead to propellant freezing. This could be particularly critical if it occurred in one of the propellant lines or manifolds.

6. *Thermal Recommendation*

Radiator Louvers

Since the louvers are operated individually the failure of one or more louver elements would just degrade the performance of the radiator and not render it inoperable. The mitigation approach is to provide a redundant radiator. This could compensate for any problem that is caused by one of the louver failures.

Heat Pipes

The mitigation approach is to utilize micro meteor shielding on any exposed heat pipes (those going to the radiator), inspect any welds made in the pipes and design the system to minimize stress on the heat pipes.

Heaters

The mitigation approach is to utilize redundant heaters and multilayer insulation in order to minimize any effects of a heater failure.

VI. Cost, Risk and Reliability

A. Costing

The following cost estimates for Case 2 and Case 4 (AMBR Engines) are developed at the subsystem and component levels using mostly mass-based parametric estimates. Test hardware costs assume one-half units for subsystem/component testing and one flight spare where appropriate. Quantitative risk analysis performed on S/C cost using Monte Carlo simulation based on mass and CER uncertainties.

Table 29 provides a comparison of the prime contractor development and manufacturing costs for these two S/C cost estimates in FY09\$M. Case 2 consists of two primary spaceract (return stage[not separated] and sep stage) while Case 4—One AMBR was estimated as a single stage. The cost comparison of these two options is as follows:

Table 29. Cost Comparison of Case 2, and Case 4—One AMBR

| WBS | Description | Case 2 | | | Case 4—AMBR Engines | | |
|----------------------------|----------------------------------|--------------|-----------------|------------------|---------------------|-----------------|------------------|
| | | DDT&E Total | Flight Hardware | Mfg/ DDT&E Total | DDT&E Total | Flight Hardware | Mfg/ DDT&E Total |
| Return Stage | | | | | | | |
| 06.1 | Sample Collection Device | 6.8 | 0.3 | 7.0 | 6.8 | 0.3 | 7.0 |
| 06.2 | Spacecraft Bus | 101.7 | 60.1 | 161.8 | 158.3 | 80.7 | 239.0 |
| 06.2.1 | Attitude Determination & Control | 30.0 | 27.7 | 57.7 | 30.0 | 27.7 | 57.7 |
| 06.2.2 | Command and Data Handling | 29.3 | 11.8 | 41.1 | 29.3 | 11.8 | 41.1 |
| 06.2.3 | Communications and Tracking | 18.1 | 12.5 | 30.6 | 15.7 | 11.3 | 27.0 |
| 06.2.4 | Electrical Power Subsystem | 6.7 | 2.9 | 9.6 | 23.4 | 6.8 | 30.2 |
| 06.2.5 | Thermal Control (Non-Propellant) | 6.3 | 1.3 | 7.5 | 7.6 | 1.4 | 8.9 |
| 06.2.6 | Propulsion | 8.3 | 2.6 | 10.9 | 27.6 | 9.7 | 37.3 |
| 06.2.7 | Propellant | 0.0 | 0.0 | 0.0 | 0.0 | 0.0 | 0.0 |
| 06.2.8 | Structures and Mechanisms | 3.0 | 1.4 | 4.4 | 24.7 | 12.0 | 36.7 |
| Systems Integration | | 37.8 | 17.8 | 55.6 | 61.3 | 23.1 | 84.4 |
| Subtotal | | 146.3 | 78.2 | 224.4 | 226.4 | 104.0 | 330.4 |
| SEP Stage | | | | | | | |
| 07.1.1 | Avionics | 3.7 | 1.9 | 5.6 | | | |
| 07.1.2 | Communications and Tracking | 0.9 | 0.7 | 1.6 | | | |
| 07.1.4 | Electrical Power Subsystem | 46.1 | 27.9 | 73.9 | | | |
| 07.1.5 | Thermal Control (Non-Propellant) | 6.4 | 1.1 | 7.5 | | | |
| 07.1.6 | Structures and Mechanisms | 17.5 | 7.1 | 24.6 | | | |
| 07.1.7 | Propulsion System | 15.5 | 18.2 | 33.7 | | | |
| 07.1.8 | Propellant | 0.0 | 0.0 | 0.0 | | | |
| Systems Integration | | 34.1 | 16.9 | 51.0 | | | |
| Subtotal | | 124.2 | 73.8 | 198.0 | | | |
| Total Prime Cost | | 270.5 | 152.0 | 422.4 | 226.4 | 104.0 | 330.4 |

The major cost difference between these two estimates can largely be attributed to the power requirements of Case 2. The approach to use an SEP stage instead of an integrated SEP vehicle is based on the possibility of an SEP stage being developed for other missions so that its use in this mission would not require a large DDT&E (as is shown.) With this savings the costs of Case 2 and Case 4 are thought to be similar.

B. Risk Analysis and Reduction

Risk Analysis addressed major mission events and risk issues associated with key S/C systems.

1. Assumptions

It was assumed that risks and reliabilities of hardware that were common to both chosen configurations would be approximately the same.

2. Risk List

Table 30 summarizes the risk issues or events which apply to both selected S/C configurations. The following table summarizes the risk issues or events which apply to two of the four spacecraft configurations, 2 (all SEP) and 4 (all CP with AeroBraking):

Table 30. Summary of Risk Issues or Events Applicable for Both S/Cs

| Item | Both Options |
|-----------------------|--|
| Top-Level | Sample acquisition and capture at Mars Sample release and deposit at Earth Elimination of all staging events, earth flyby |
| System | Single fault tolerant designs |
| Mission, Ops, GN&C | Rendezvous and capture maneuvers for sample sphere |
| Launch Vehicle | Survive launch acceleration loads |
| Propulsion | Time of operation No. of on/off cycles Hardware redundancy |
| Power | SA deployment |
| Thermal & Environment | Deep Space Radiation level @ 5 AU Micrometeoroid environment in Mars orbit Heat pipe puncture → Overheat Louver fails closed → Overheat Louver fails open → Overcool |

Table 31 summarizes the risk issues or events which apply uniquely to the MERV Option #2 All-SEP configuration.

Table 31. Summary of Risk Issues or Events Applicable to MERV Option 2 All-SEP

| Item | MERV Option 2—All SEP |
|-----------------------|---|
| Top-Level | Time in space environment = 3.25 yr |
| Mission, Ops, GN&C | Long SEP thrusting times |
| Power | More solar cells and longer exposure to space environment |
| Thermal & Environment | Larger thermal system (radiators, heat pipes, louvers) to handle waste heat |

Table 32 summarizes the risk issues or events which apply uniquely to the MERV Option 4 all-CP with one AMBR/aero-braking configuration.

Table 32—Summary of Risk Issues or Events Applicable to MERV Option 4 All-CP with One AMBR/Aero-Braking

| Item | MERV Option 2—All CP (One AMBR/A-B) |
|--------------------|--|
| Top-Level | Time in space environment = 2.5 yr |
| Mission, Ops, GN&C | High thrust events at TEI, MOI, Mcirc Aerobraking operationally intense: <ul style="list-style-type: none"> • S/C reconfigured every orbit • Orbit assessment every orbit |

| | |
|-------------------------|--|
| Propulsion | <ul style="list-style-type: none"> Frequent orbit adjustment burns Primary: Outbound-2 burns; Return-2 burns; 1+1 = 1FT Secondary: hydrazine, 1 or 5 lbf thrusters |
| Avionics/Communications | Aerobraking communications outage (requiring a safing capability) |
| Thermal & Environment | Aerobraking thermal cycling on SAs, comm antennas, S/C body & tanks; GNC instruments |
| Structures | Aerobraking structural loads on S/C, SAs, appendages, GNC, comm, science collection devices |

3. Risk Summary

These risks, with proper pro-active planning, can be mitigated early to avoid becoming problems late in the development life cycle.

C. Reliability

Overall probability of Mission Success (Reliability) is already taxed by the requirement of two launches to carry out the entire mission. The launch of the MERV has many “events” which, if any are unsuccessful, could result in the loss of the entire mission. Reference 3 “Aerobraking Cost and Risk Decisions,” provides a top-level Success estimate for an all-chemical-propulsion option including multiple candidate mission events. A quick-look reliability evaluation based on the reliability (i.e., probability of success) numbers in this reference was applied to four of the MERV study configurations and is summarized as follows in Table 33.

Table 33. Reliability Evaluation

| Mission Event | Reliability | | | | | | |
|--|------------------------|----------------------------------|---------------------------------------|----------------------------------|---------------------------|-----------------|-----------------------------|
| | Values in Orig. Report | Values in Orig. Report minus A-B | Values in Orig. Report with Gaps=0.99 | MERV#1 (SEP Outbound, CP Return) | MERV#2 Baseline (All SEP) | MERV#3 (All CP) | MERV#4 AMBR (All CP w. A-B) |
| Launch | 0.96 | 0.96 | 0.96 | 0.96 | 0.96 | 0.96 | 0.96 |
| Cruise (Earth to Mars) | 0.99 | 0.99 | 0.99 | 0.97 | 0.97 | 0.99 | 0.99 |
| Earth Flyby | ? | ? | 0.99 | | | | |
| Mars Orbit Insertion | 0.95 | 0.95 | 0.95 | 0.98 | 0.98 | 0.95 | 0.95 |
| Aero-Braking | 0.97 | | 0.97 | | | | 0.94 |
| Sample Acquisition/ Capture | ? | ? | 0.99 | 0.99 | 0.99 | 0.99 | 0.99 |
| Staging | ? | ? | 0.99 | | | | |
| Mars Orbit Departure | ? | ? | 0.99 | 0.97 | 0.99 | 0.97 | 0.97 |
| Cruise (Mars to Earth) | 0.99 | 0.99 | 0.99 | 0.99 | 0.99 | 0.99 | 0.99 |
| Sample Targeting and Arrival | ? | ? | 0.99 | 0.99 | 0.99 | 0.99 | 0.99 |
| Overall Reliability (1-Sum(Pf's)) | 0.860 | 0.890 | 0.810 | 0.850 | 0.870 | 0.840 | 0.780 |

For those who prefer a view of the Reliability from a “Probability of Failure” perspective, Table 34 is presented.

Table 34. Probability of Failure

| Mission Event | Probability of Failure (Pf) | | | | | | |
|-------------------------------|-----------------------------|----------------------------------|---------------------------------------|----------------------------------|-------------------------------|-----------------|-----------------------------|
| | Values in Orig. Report | Values in Orig. Report minus A-B | Values in Orig. Report with Gaps=0.01 | MERV#1 (SEP Outbound, CP Return) | MERV#2 --- Baseline (All SEP) | MERV#3 (All CP) | MERV#4 AMBR (All CP w. A-B) |
| Launch | 0.04 | 0.04 | 0.04 | 0.04 | 0.04 | 0.04 | 0.04 |
| Cruise (Earth to Mars) | 0.01 | 0.01 | 0.01 | 0.03 | 0.03 | 0.01 | 0.01 |
| Earth Flyby | | | 0.01 | | | | |
| Mars Orbit Insertion | 0.05 | 0.05 | 0.05 | 0.02 | 0.02 | 0.05 | 0.05 |
| Aero-Braking | 0.03 | | 0.03 | | | | 0.06 |
| Sample Acquisition/ Capture | | | 0.01 | 0.01 | 0.01 | 0.01 | 0.01 |
| Staging | | | 0.01 | | | | |
| Mars Orbit Departure | | | 0.01 | 0.03 | 0.01 | 0.03 | 0.03 |
| Cruise (Mars to Earth) | 0.01 | 0.01 | 0.01 | 0.01 | 0.01 | 0.01 | 0.01 |
| Sample Targeting and Arrival | | | 0.01 | 0.01 | 0.01 | 0.01 | 0.01 |
| Overall Pf (Sum(Pf's)) | 0.140 | 0.110 | 0.190 | 0.150 | 0.130 | 0.160 | 0.220 |

Table 35 highlights the differences between the cases presented above and is intended to show the progression of the simplified reliability analyses.

Table 35. Difference Between Proposed Options

| Option | Description |
|--------|---|
| 1 | Shows assumed event and resultant Mission reliabilities in the original report. |
| 2 | Shows assumed event reliabilities in the original report minus the Aero-Braking event and resultant Mission reliability. |
| 3 | Case 1 reliabilities plus 0.99 for event reliabilities not included in Case 1. |
| 5 | Case 3 reliabilities minus Earthy Flyby, Aero-braking, and Staging events. SEP reliabilities based on analysis summarized below. Corresponds to MERV configuration 2. |
| 7 | Case 3 reliabilities minus Earthy Flyby and Staging events. Mars Orbit Departure was assumed to be less risky than Mars Orbit Insertion (which requires more detailed GN&C, etc., events); assumed reliability = 0.97. Corresponds to MERV configuration 4. |
| 4 | Case 5 reliabilities for SEP operations and Case 7 reliabilities for CP operations (minus Aero-Braking). Corresponds to MERV configuration 1. |
| 6 | Case 7 reliabilities for CP (minus Aero-Braking). Corresponds to MERV configuration 3. |

The difference between Cases 1 and 2 shows the reliability impact of dropping Aero-Braking. The difference between Cases 5 and 7 shows the combined reliability impact of dropping Aero-Braking *and* the assumed reliability difference between all SEP-versus-all CP main propulsion systems. This initial assessment shows the positive impact on spacecraft reliability from dropping significant mission events. It also appears to indicate that the differences in event reliabilities of the propulsion system hardware options are the primary of the remaining drivers of spacecraft reliability. Therefore, more detailed reliability assessments were carried out to evaluate these differences.

For the MERV Configuration 2 all-SEP system, a simple reliability analysis including only SEP-related elements was performed using the RAPTOR code. RAPTOR uses a Monte Carlo-based analysis methodology on a Reliability Block Diagram (RBD) model of the system. The RBD model used for the SEP system is as follows in Figure 42.

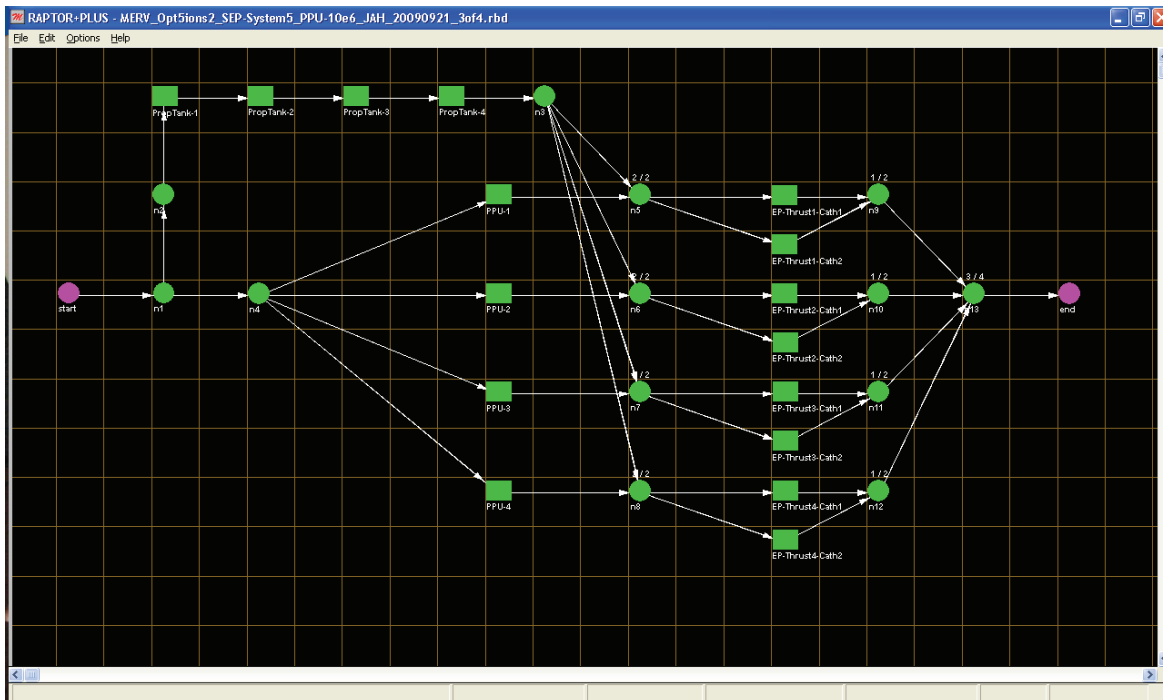

Figure 42. RBD Model of the SEP System

The Mean Time to Failure (MTTF) values assumed for each RBD element shown above is summarized in Table 36.

Table 36. MTTF Values for Each RBD Element

| Block Name | MTTF (hr) | MTTF Source |
|--|-----------|---|
| PropTank-1 thru PropTank-4 | 1094092 | 2007 SEP Saturn Orbiter reliability analysis by Bill Strack showed Failure Rate = 9.14×10^{-7} for Xe propellant tank. |
| PPU-1 thru PPU-4 | 1000000 | Found MTTF estimates ranging from 43,860 to 3,703,703 hr. Picked a rounded-off moderate value. |
| EP-Thrust1-Cath1 thru EP-Thrust4-Cath2 | 62490 | (1) Max demonstrated full-throttle cathode life = 30,352 hr. (2) Applied Relx Software "Calculating MTTF when you have zero failures" = 1.4427 * Demonstrated life = 43,789 hr at 50% confidence level. (3) Adjusted lifetime upward based on lower average throttle levels during each mission segment using data in Table 4 of AIAA-2008-5207, yielding indicated MTTF. |

The assumed SEP operating timeline and cathode lifetime estimates are summarized in Table 37.

Table 37. SEP Operation Timeline and Cathode Lifetime Estimates

| Mission Segment | No. of SEP Operating Days | No. of SEP Operating Hr | Fraction of Total SEP Operation | Estimated EP Avg. Throttle Setting | Estimated Cathode Lifetime at Throt. Setting |
|------------------------------|---------------------------|-------------------------|---------------------------------|------------------------------------|--|
| Earth-to-Mars Transit-Part 1 | 74.6 | 1790.4 | 0.10982 | 0.961 | 30821 |
| Earth-to-Mars Transit-Part 2 | 175.4 | 4209.6 | 0.25821 | 0.698 | 72204 |
| Spiral into LMO | 182.5 | 4380 | 0.26866 | 0.696 | 72537 |
| Spiral out from LMO | 112 | 2688 | 0.16488 | 0.805 | 54968 |
| Mars-to-Earth Transit | 134.8 | 3235.2 | 0.19844 | 0.773 | 60025 |
| Totals or Averages | 679.3 | 16303.2 | 1.00000 | 0.759 | 62490 |

For 16,303 hr of SEP system operating time, the RAPTOR analysis yielded a SEP system reliability of 0.922. The reliability values noted in the summary table above were derived by proportioning Mission Probability of Failure, Pf ($1 - 0.922 = 0.078$) based on the fraction of SEP operating time associated with each Mission Segment.

For the MERV Configuration 4 "All CP+A/B" case, the reliability value for the Aerobraking phase was determined by doubling the aerobraking Pf because the aerobraking *period* was doubled from 3 months in the reference estimate to 6 months in our mission timeline (i.e., new A/B phase reliability = $1 - 2*(1 - 0.97) = 0.94$). The other Reliability adjustment for this option was to the Mars Orbit Departure phase. It was assumed that the risks associated with outbound targeting, etc., events would reduce the Pf for this phase (compared to Mars Orbit Insertion) by a guesstimate of 40%. A more detailed analysis is required to verify this.

One negative reliability impact of the All SEP case is longer cruise/spiral times (estimated to be 3.25 yr versus 2.5 yr for the Configuration 4 CP+A/B case). It is anticipated that this can be offset with proper SEP redundancy and other mitigation strategies.

The electric propulsion vehicle has heritage from both SMART-1 and Hyabusa which were successful, long term primary ΔV EP missions: (1) SMART-1 spiraled from GTO to Moon and down to LLO; (2) Hyabusa SEP propelled the spacecraft to the Asteroid and back (even with failure of the wheels and RCS elements).

VII. Summary

The COMPASS Team was tasked with the design of a Mars sample return vehicle. The current Mars sample return mission is a joint NASA and ESA mission, with ESA contributing the launch vehicle for the Mars sample return craft. The COMPASS Team ran a series of design trades of a Mars sample return vehicle. Four design options were investigated: Chemical Return/SEP stage outbound, all-SEP, all chemical and chemical with aerobraking. SEP can eliminate both the Earth flyby and the aerobraking maneuver (both considered high risk by the Mars Sample Return Project) required by the chemical propulsion option but also require long low thrust spiral times. However this is offset somewhat by the chemical missions use of an Earth flyby and aerobraking which also take many

months. The Ariane 5 launch vehicle is the ESA contribution to the mission and could allow the use of a 22 kW SEP stage (using two 7.7 m Ultraflex SA).

Table 38 gathers the two baselined designs (an all SEP case designated Case 2, and a chemical case designated Case 4 AMBR) reported in detail in this document in a side by side comparison of major details such as propulsion system type, vehicle size, mission trip times, etc. The chemical system uses a single AMBR engine and the SEP case uses BPT-4000 electric thrusters.

Table 39. Top Level Baseline (Case 2 and Case 4—One AMBR) Comparison

| All SEP and Chemical-Aerobrake Comparison | | |
|---|--|---|
| Vehicle | SEP | Chemical/aerobrake |
| Size | Slightly larger arrays | Slightly longer vehicle (more propellant) |
| Mission time | 373 d outbound to Mars, 185 spiral at Mars | 457 d outbound trip time |
| Critical events | Array deployment, sample capture/handling/deployment | Array deployment, Sample capture/handling/deployment, >four primary chemical burns, 6 months of aerobraking |

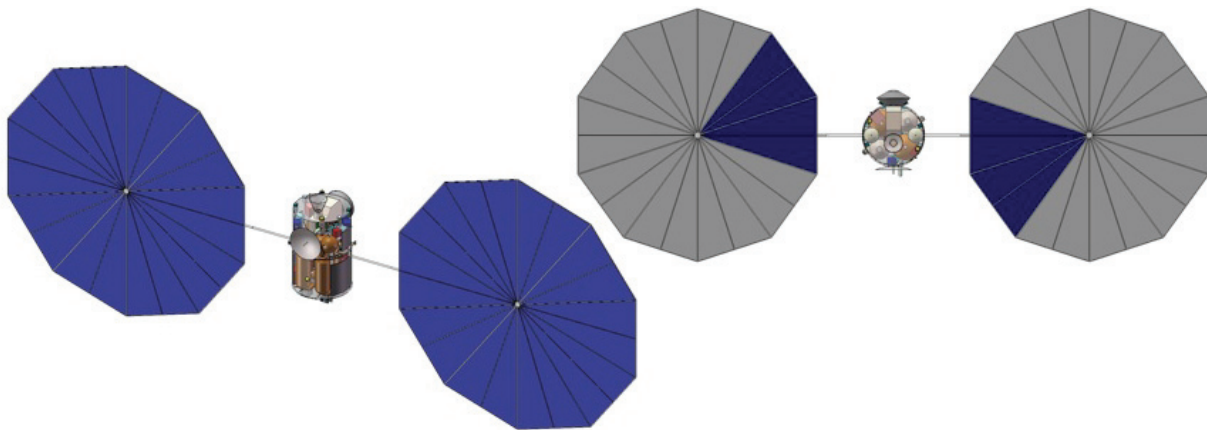

Figure 43. MERV Sample Return Craft—Baseline Designs

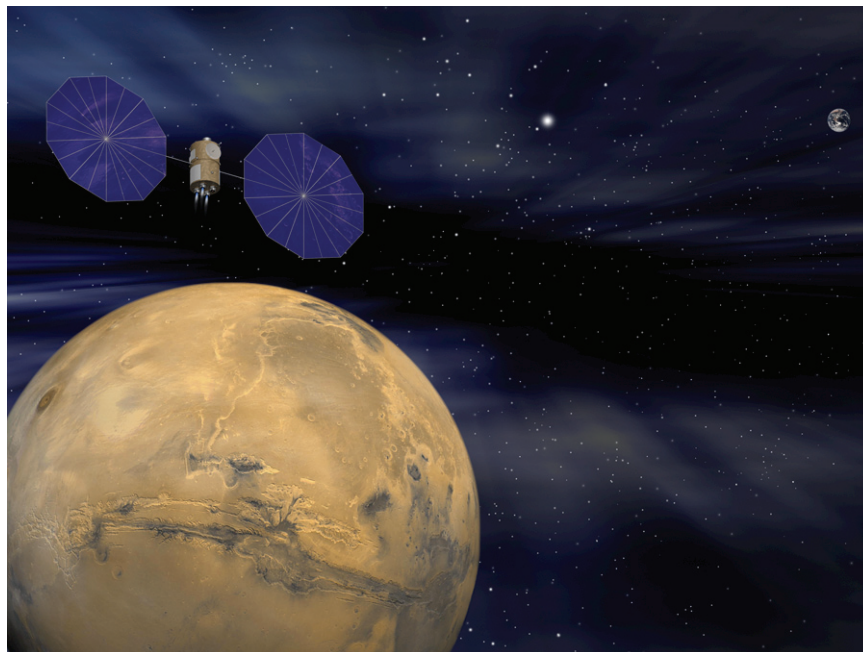

Figure 44. Artists' Rendering of MERV Sample Return Craft

Table 40 collects the details of the subsystems at a top level in the all SEP design, designated Case 2 in our trade space Table 40. Because two MELs were used in the technical design during the design session, two numbers are sited in several sections for total mass in Table 40. The use of two separate MELs offered ease of design changes between Cases 1 and 2. Things were easily switched between the chemical/SEP case (designated Case 1) vehicles and then the all-SEP vehicle. Note that the total mass with growth for the top-level system (first row in Table 40) is less than the launch vehicle capability. This difference is the 10% margin carried on the launch vehicle performance and was discussed previously in the document.

Table 40. Case 2 (All SEP) Mission and Spacecraft (S/C) Summary: SEP Stage

| Subsystem area | Details | Total mass with growth |
|--------------------------------------|--|--|
| Top level system | 2022 launch, 373 d to Mars, 185 spiral at Mars, Ariane 5 ECA launcher (ESA contribution. Allows potential reuse of SEP module designs from other flagship missions (e.g., Titan Saturn System Mission (TSSM)). | 3297.5 kg |
| Mission, operations, GN&C | 373 d to Mars, 185 spiral at Mars, use an SEP module approach (power and electric propulsion module) but SEP module not jettisoned; Payload module added to forward end of stage | 70 kg |
| ACS | Hydrazine mono-prop for RCS, used during close approach to and sample collection | 60.4 kg |
| Launch | 2022 launch, Ariane 5 ECA launcher (ESA contribution) | 3667 kg capability |
| Science | Sample Collection system based on the JPL/ESA design | 76.5 kg |
| Power | Two single axis 7 m Ultraflex SA (~24 kW beginning of life (BOL)) | 38.9 kg on return stage MEL + 388.3 kg on all-SEP MEL = 427.2 kg |
| Propulsion | EP thrusters, propellant, tanks, feed systems, Digital Control Interface Units (DCIU), SAs, 1736 kg Xe in COPV tanks: Single Spherical or multiple cylindrical 3+1 BPT-4000 Hall propulsion systems | 285 kg |
| Structures and mechanisms | Minimize deployables/mechanisms (only sample rendezvous and collection systems, power, communications) Collection systems, sample capsule loading/sealing/separation, SAs Structures: Composite thrust tube at 1.6 m to match Ariane 5 adapter dimensions | 49.4 kg on return stage MEL + 150.6 kg on all-SEP MEL = 200 kg |
| Communications | One fixed antenna back to Earth X band, Omni-antennas for 10 to 100 bps UHF antenna for communicating with other Mars orbiting assets, maybe a lander | 52.8 kg on return stage MEL+ 1.4 kg on all-SEP MEL = 54.2 kg |
| C&DH | Fault tolerant control systems Wide and near angle cameras for sample rendezvous and capture | 42.8 kg |
| Thermal | MLI with heaters, radiators for avionics and EP power processing waste heat | 38.9 kg on return stage MEL+ 94.2 kg on all-SEP MEL = 133.1 |

The approach for Case 4 (Aerobraking with a capture stage) was to use the return vehicle from Case 1 and Modify the SEP MEL stage from Case 1 to provide a chemical capture system and Drag Flaps. The change in performance to the target is indicative of the change in launch year, and the reduced C_3 for the mission in this “easier” launch opportunity. Note that the total mass with growth for the top-level system (first row in Table 41) is less than the launch vehicle capability.

Table 41. Case 4—One AMBR Mission and S/C Summary

| Subsystem area | Details | Total mass with growth |
|--------------------------------------|---|------------------------------------|
| Top level system | 2024 launch, (2022 launch not feasible with Ariane 5), 457 d outbound trip time, Ariane 5 ECA launcher (ESA contribution). AMBR engine enables mission (provides 10% launch margin) | 3590 kg |
| Mission, operations, GN&C | Chemical Capture into 24 hr orbit, Aerobraking into 500 km circular sample rendezvous orbit, Chemical return to Earth, no- jettisoning | 69.6 kg |
| ACS | Hydrazine mono-prop for RCS, sample close approach and collection | Included in propulsion system mass |
| Aerobraking System | Large area (6.5 m ²) needed for a 6 month aerobrake campaign Large (6 m diameter) Ultraflex SA used as drag flaps, also carries solar cells on 5% of array | 60 kg (carried in structures) |
| Launch | 2024 launch, (2022 launch not feasible with Ariane 5) Ariane 5 ECA launcher (ESA | 4000 kg capability |

| | | |
|----------------------------------|--|----------|
| | contribution). | |
| Science | Sample Collection system based on JPL/ESA design | 76.5 kg |
| Power | 750 W BOL on two small portions of Ultraflex drag flaps Fault tolerant control systems Wide and near angle cameras for sample rendezvous and capture | 64.9 kg |
| Propulsion | AMBR engine enables mission (provides 10% launch margin) | 276.7 kg |
| Structures and mechanisms | Minimize deployables/mechanisms (only sample rendezvous and collection systems, power, communications): Collection systems, Sample Capsule loading/sealing/separation, Drag Flaps Structures: Composite Thrust tube at 1.6 m to match Ariane 5 adapter dimensions | 297.8 kg |
| Communications | One fixed antenna back to Earth X-band, Omni-antennas for 10 to 100 bps UHF antenna for communicating with other Mars orbiting assets, maybe lander | 52.8 kg |
| C&DH | Fault tolerant control systems Wide and near angle cameras for sample rendezvous and capture | 42.8 kg |
| Thermal | MLI with heaters, radiators for avionics and EP power processing waste heat | 48.7 kg |

Cases 2 and 4 show two very different approaches to the MERV design. While the Chemical/Aerobraking case 4 is less expensive it has more events, an admittedly risky six month aerobraking campaign and can not fit on the desired launcher (Ariane 5) except for one launch year. The added cost of the SEP approach (~\$90M for a Flagship mission [$> \$2B$]) is probably worth the cost in order to increase reliability (up to 0.87 from 0.78) and allow for more launch year opportunities on the Ariane V. The \$90M difference could be reduced if an SEP stage can be obtained from another program or the SEP system is integrated into the sample capture craft. Further studies are recommended to explore these options as well as use of an SEP system to deliver both the lander and the return vehicle, thus eliminating a launch as well as the cruise stage for the lander.

Acknowledgments

The authors would like to thank the COMPASS Team Members: Les Balkanyi, Laura Burke, Tony Colozza, John Dankanich, Jon Drexler, Ian Dux, James Fincannon, James Fitje, John Gyekenyesi, Joe Hemminger, Mike Martini, T.C. Nguyen, Tom Packard, Tom Parkey, Carl Sandifer, Tim Sarver-Verhey, Anita Tenteris, Joe Warner, Glenn Williams, and Jeff Woytach.

Appendix A—Acronyms and Abbreviations

| | | | |
|---------|---|-------|--------------------------------------|
| ACS | Attitude Control System | DSN | Deep Space Network |
| Al | aluminum | DTE | direct to Earth |
| AMBR | Advanced Materials Bi-propellant Rocket | DV | Delta V (change in Velocity) |
| AO | Announcement of Opportunity | ECA | Evolution Core Ariane |
| BOL | Beginning of Life | EELV | Evolved Expendable Launch Vehicle |
| C&DH | Command and Data Handling | EEV | Earth Entry Vehicle |
| CBE | current best estimate | EIRP | Effective Isotropic Radiated Power |
| CCB | Common Core Booster | ELV | Expendable Launch Vehicle |
| Cd | Coefficient of drag | EMI | Electro Magnetic Interference |
| CEV | Crew Exploration vehicle | EP | Electric Propulsion |
| Comm | Communications | ERV | Earth Return Vehicle |
| COMPASS | Concurrent Multidisciplinary Parametric Assessment of Space Systems | ESA | European Space Agency |
| | | ESPA | EELV Secondary Payload Adaptor |
| | | FEA | finite element analysis |
| | | FOM | figure of merit |
| COPV | Composite Overwrapped Pressure Vessel | GLIDE | GLobal Integrated Design Environment |
| | | GMT | Greenwich Mean Time |
| COTS | Commercial off the Shelf | GN&C | Guidance, Navigation and Control |
| CSA | Canadian Space Agency | GRC | NASA Glenn Research Center |
| DCIUs | Digital Control Interface Unit | GSFC | NASA Goddard Space Flight Center |
| DMR | Design for Minimum Risk | GTO | Geo-Transfer Orbit |
| DOF | Degree of Freedom | HQ | NASA Headquarters |
| DPAF | Dual Payload Attach Fitting | | |

| | | | |
|-----------|--|---------|--|
| IMEWG | International Mars Exploration Working Group | MTTF | Mean Time To Failure |
| | | NAC | Narrow Angle Camera |
| IP | Internet protocol | NASA | National Aeronautics and Space Administration |
| ISC | Inertial Stellar Compass | | |
| ISRU | in situ resource utilization | Nav | Navigation |
| JAXA | Japan Aerospace Exploration Agency | NLS | NASA Launch Services |
| JPL | NASA Jet Propulsion Laboratory | NTO | Nitrogen tetroxide |
| KSC | NASA Kennedy Space Center | OS | Orbiting Sample |
| LEO | Low Earth Orbit | PAF | Payload Attach Fitting |
| Li | Lithium | PEL | Power Equipment List |
| LLO | Low Lunar Orbit | PLF | Payload Fairing |
| LMO | Low Mars Orbit | PPU | Power Processing Unit |
| LNS | layer 2 tunneling protocol network server | RBD | Reliability Block Diagram |
| | | RCS | Reaction Control System |
| LSP | Launch Service Program | S/C | S/C |
| LSTO | Launch Service Task Order | SA | solar array |
| MALTO | Mission Analysis Low-thrust Trajectory Optimization | SADA | Solar Array Drive Assembly |
| | | SEP | Solar Electric Propulsion |
| MAV | Mars Ascent Vehicle | SMART-1 | Small Missions for Advanced Research in Technology-1 |
| MEL | Master Equipment List | | |
| MEMs | Microelectromechanical systems | SN | signal-to-noise |
| MER | Mars Exploration Rover | SPACE | System Power Analysis for Capability Evaluation |
| MERV | Mars Earth Return Vehicle | | |
| MESSENGER | Mercury Surface, Space Environment, Geochemistry and Ranging | SPU | Solar Power Unit |
| | | TDRSS | Tracking and Data Relay Satellite System |
| MGA | Mass Growth Allowance | | |
| MGS | Mars Global Surveyor | TEI | Trans Earth Injection |
| MMH/NTO | monomethyl hydrazine/nitrogen tetroxide | Ti | titanium |
| | | TSSM | Titan Saturn System Mission |
| MOI | Mars Orbit Insertion | TWTA | Traveling Wave Tube Amplifier |
| MPU | Makeup Power Unit | UHF | Ultra High Frequency |
| MRO | Mars Reconnaissance Orbiter | USO | Ultra-stable oscillator |
| MSR | Mars Sample Return | WAC | Wide Angle Camera |
| MTO | Mars Telecommunications Orbiter | Xe | xenon |

References

- ¹ AIAA S-120-2006, AIAA Standard Mass Properties Control for Space Systems.
- ² Preliminary Planning for an International Mars Sample Return Mission, Report of the International Mars Architecture for the Return of Samples (iMARS) Working Group, June 1, 2008.
- ³ Spencer, D.A., Tolson, R., Aerobraking Cost and Design Considerations, Journal of Spacecraft and Rockets, Vol. 44, No. 6, Nov/Dec. 2007

Bibliography

- A.C. Klein and W.F. Vogelsang, RAPTOR: A Computer Code to Calculate the Transport of Activation Products in Fusion Reactors, Feb. 1984, UWFD-567.
- Aerojet engines and propellant systems (<http://www.aerojet.com/capabilities/spacecraft.php>)
- Annalisa L. Weigel and Daniel E. Hastings, Evaluating the Cost and Risk Impacts of Launch Choices, Journal Of Spacecraft and Rockets, Vol. 41, No. 1, Jan.-Feb. 2004.
- ANSI/AIAA R-020A-1999, Recommended Practice for Mass Properties Control for Satellites, Missiles, and Launch Vehicles.
- Arde, Inc. Propellant Storage Tank Specifications, www.ardeinc.com
- ATK/PSI Propellant Storage Tank Specifications, www.psi-pci.com
- Bejan, A. and Kraus, A.D., Heat Transfer Handbook, John Wiley & Sons, 2003.
- Bishop, Robert H., Dennis V. Byrnes, Dava J. Newman & Christopher E. Carr, Buzz Aldrin, Earth-Mars Transportation Opportunities: Promising Options for Interplanetary Transportation, Paper AAS 00-255, The Richard H. Battin Astrodynamics Conference, College Station, TX, March 2000.
- Brown, Charles D., *Spacecraft Propulsion*, AIAA, 1996

D. Persons, L. Mosher, T. Hartka, The NEAR and MESSENGER Spacecraft: Two Approaches to Structure and Propulsion Design, AIAA-00-1406, A00-24531,

Douglas Feihler and Steven Oleson, *A Comparison of Electric Propulsion Systems For Mars Exploration*, 39th AIAA/ASME/SAE/ASEE Joint Propulsion Conference and Exhibit, 20-23 July 2003, Huntsville, AL, AIAA-2003-4574.

Gilmore, David G. (ed.), *Spacecraft Thermal Control Handbook: Volume 1 Fundamental Technologies*, AIAA, 2002.
http://www.esa.int/esaMI/Aurora/SEMCWB1A6BD_0.html

Hyder, A.J., Wiley, R.L., Halpert, G., Flood, D.J. And Sabripour, S. *Spacecraft Power Technologies*, Imperial College Press, 2000.

iMARS: http://www.nasa.gov/home/hqnews/2007/dec/HO_07269_Mars_Samples.html

Incopera, F.P. And DeWitt, D.P., *Fundamentals of Heat and Mass Transfer*, John Wiley and Sons, 1990.

International Launch Systems (ILS), "Atlas Launch System Planner's Guide," Rev. 9, Sep. 2001.

Kevin E. Witzberger and Dave Manzella, *Performance of Solar Electric Powered Deep Space Missions Using Hall Thruster Propulsion*, AIAA/ASME/SAE/ASEE Joint Propulsion Conference, 10-13, July 2005, Tucson, AZ., AIAA-2005-4268.

Larson, W.J. And Wertz, J.R., *Space Mission Analysis and Design*, Third Edition, Space Technology Library, Microcosm Press, 1999.

M. D. Johnston, P. B. Esposito, V. Alwar, S. W. Demcak*, E. J. Graat, R. A. Mase "Mars Global Surveyor Aerobraking at Mars," AAS 98-112 <http://Mars.jpl.nasa.gov/mgs/sci/aerobrake/SFMech.html>

Mars reference page: http://www.nasa.gov/mission_pages/Mars/main/index.html

MatWeb Material Property Data, www.matweb.com

Morton Thiokol, Inc., "Space Rocket Motors," June 1987.

New Frontiers AO information: AMBR, Aug. 2008, http://ntrs.nasa.gov/archive/nasa/casi.ntrs.nasa.gov/20080047426_2008047215.pdf

NIST Thermodynamic Properties Data, www.nist.gov

Preliminary Planning for an International Mars Sample Return Mission, Report of the iMARS (International Mars Architecture for the Return of Samples) Working Group, June 1, 2008. http://mepag.jpl.nasa.gov/reports/iMARS_FinalReport.pdf

R. Williams, Y. Gao, C.A. Kluever, M. Cupples, J. Belcher, "Interplanetary Sample Return Missions Using Radioisotope Electric Propulsion," 41st AIAA/ASME/SAE/ASEE Joint Propulsion Conference & Exhibit, 10-13 Jul. 2005, Tucson, AZ, AIAA-2005-4273.

Robert Dillman and James Corliss, Overview of the Mars Sample Return Earth Entry Vehicle,

Sauer, C., "A Users Guide to VARITOP: A General Purpose Low-Thrust Trajectory Optimization Program," Advanced Projects Group, Jet Propulsion Laboratory, Nov. 1991.

Space Mission Analysis and Design, 3rd edition (Space Technology Library), Wiley J. Larson and James R. Wertz (eds.), Oct. 1999.

Star Motor reference pages from ATK. (http://www.atk.com/starmotors/starmotors_star48v.asp)

The Boeing Company, "Delta IV Payload Planner's Guide Update—April 2002," MDC 00H0043, April 2002.

The Boeing Company, "Delta IV Payload Planner's Guide," MDC 00H0043, October 2000.

Viking '75 Spacecraft Design and Test Summary Volume III—Engineering Test Summary, NASA Reference Publication 1027, Nov. 1980.

Zubrin, Robert, "A comparison of approaches for the Mars Sample Return Mission," AIAA 34th Aerospace Sciences Meeting and Exhibit, Reno, NV, Jan. 15-18, 1996, A9618450, AIAA Paper 96-0489.